



Model 109PC HORIZONTAL SLICER

Parts List, Installation and Operating Instructions



IMPORTANT SAFETY NOTICE



This Manual contains important safety instructions which must be strictly followed when using this equipment.

TABLE OF CONTENTS

	Page
NOTICE TO OWNERS AND OPERATORS	1
SAFETY TIPS	2
INSTALLATION	3
OPERATION	
KEYPAD OPERATION	4
MACHINE OPERATION	6
KEY PAD ILLUSTRATION	7
SYSTEM ERRORS	8
CLEANING	9
PARTS DIAGRAMS	10
WIRING DIAGRAM: 208/230/460V-60HZ-3PH	17
WIRING DIAGRAM: 380/415V-50HZ-3PH	20
WIRING DIAGRAM: STEPPER MOTOR, ALL VOLTAGES	23
MAINTENANCE	
TIMING ADJUSTMENT	24
COMPONENT PLATE – PRODUCT PUSHER ADJUSTMENT	26
LAST CUT DISTRIBUTION	26
ELECTRICAL	28
TROUBLE SHOOTING PC BOARDS	29
RECOMMENDED SPARE PARTS LIST	30

LIMITED WARRANTY

WARRANTY: The BIRO Manufacturing Company warrants that Model 109PC Horizontal Slicer will be free from defects in material and workmanship under normal use and with recommended service. BIRO will replace defective parts, which are covered by this limited warranty, provided that the defective parts are authorized for return, shipping charges prepaid, to a designated factory for inspection and/or testing.

DURATION OF WARRANTY: The warranty period for all parts covered by this limited warranty is one (1) year from inspection/demonstration advised on returned warranty registration card, or eighteen (18) months from original factory shipping date, whichever occurs first, except as noted below.

PARTS NOT COVERED BY WARRANTY: The following are **NOT** covered by this limited warranty: Smooth blade (PC124), Serrated blade (PC125), Torsion spring (31-39). This limited warranty does not apply to machines sold as used, rebuilt, modified, or altered from the original construction in which the machine was shipped from the factory. (Water contaminated electrical systems are not covered under this limited warranty.) BIRO is not responsible for electrical connection of equipment, adjustments to switch gear or any other electrical requirements, which must be performed only by a certified electrician. BIRO is not responsible for service charges or labor required to replace any part covered by this limited warranty or for any damages resulting from misuse, abuse, lack of proper or recommended service.

EXCLUSION OF WARRANTIES AND LIMITATION OF REMEDIES: BIRO gives no warranties other than those expressly stated in this limited warranty. THE IMPLIED WARRANTY OF MERCHANTABILITY, THE IMPLIED WARRANTY OF FITNESS FOR PROCESSING OF FOOD PRODUCTS, AND ALL OTHER IMPLIED WARRANTIES ARE SPECIFICALLY EXCLUDED. BIRO IS NOT LIABLE FOR CONSEQUENTIAL OR INCIDENTAL DAMAGES, EXPENSES, OR LOSSES. THE REMEDIES PROVIDED IN THIS BIRO LIMITED WARRANTY ARE PURCHASER'S SOLE AND EXCLUSIVE REMEDIES AGAINST BIRO.

REGISTRATION CARDS: You must sign, date and complete the warranty card supplied with each machine. The warranty card must be returned to The Biro Manufacturing Company for proper registration. If no warranty card is returned to BIRO, the warranty period will begin from the date the machine was originally shipped from the factory.

HOW TO GET SERVICE:

1. Contact the agency from whom you purchased the machine.
2. Consult the yellow pages of the phone directory for the nearest authorized dealer.
3. Or call BIRO Service Department (419) 798-4451 who will put you in contact with the nearest service agency.

NOTICE TO OWNERS AND OPERATORS

BIRO's products are designed to process food products safely and efficiently. Unless the operator is properly trained and supervised, however, there is the possibility of a serious injury. It is the responsibility of the owner to assure that this machine is used properly and safely, strictly following the instructions contained in this Manual and any requirements of local law. Be sure a BIRO Authorized Representative has reviewed the installation before this machine is initially started up and put into service. Contact The Biro Mfg. Co. if you do not know who is your local Biro Representative.

No one should use or service this machine without proper training and supervision. All operators should read and be thoroughly familiar with the procedures contained in this Manual. Even so BIRO cannot anticipate every circumstance or environment in which its products will be used. You, the owner and operator, must remain alert to the hazards posed by the function of this equipment – particularly the SHARP KNIFE BLADE. No one under eighteen (18) years of age should operate this equipment. If you are uncertain about a particular task, ask your supervisor.

This Manual contains a number of safe practices in the SAFETY TIP section. Additional warnings are placed throughout the Manual. Warnings related to your personal safety are indicated by:



OR



Warnings related to possible damage are indicated by:



If any warning label or Manual becomes misplaced, damaged, or illegible, please contact your nearest Distributor or BIRO directly for a replacement.

Remember, however, this Manual or the warning labels do not replace the need to be alert and to use your common sense when using this equipment.

This Manual applies to all BIRO Model 109PC Horizontal Slicers.

THE BIRO MANUFACTURING CO.
1114 WEST MAIN STREET
MARBLEHEAD, OHIO 43440
PH: 419-798-4451
FAX: 419-798-9106
<http://www.birosaw.com>
Email: service-department@birosaw.com

SAFETY TIPS



SHARP KNIFE BLADE TO AVOID SERIOUS PERSONAL INJURY

NEVER Operate This Machine Without Proper Training and Authorization By Your Supervisor or If Under 18 Years.

ALWAYS Read Operation and Service Manual Thoroughly **BEFORE** Operating, Servicing or Cleaning.

ONLY Install on Level, Non-Skid Surface in a Clean, Well-Lighted Work Area Away From Children and Visitors.

ONLY Use a Qualified Electrician to Install According to Local Building Codes: Machine **MUST Be Properly Grounded.**

NEVER Place Hands or any Body Part in Cutting Area.

DO NOT Open Chamber Covers While Machine is Operating.

NEVER Disconnect or Bypass Safety Interlock Switches.

ALWAYS Turn Off and **UNPLUG** Machine From Power Source Before Cleaning or Servicing.

NEVER Leave Machine Unattended While Operating.

DO NOT Alter Machine.

DO NOT Operate Machine With Missing Parts.

ALWAYS Comply With all Regulations for Food Handling, Packaging, and Storing.

PROMPTLY REPLACE Any Worn or Illegible Warning and Instruction Labels.

ONLY USE BIRO Parts and Accessories Properly Installed.

INSTALLATION



TO AVOID SERIOUS PERSONAL INJURY PROPERLY INSTALL EQUIPMENT IN ADEQUATE WORK AREA

ALWAYS Use Qualified Technician and Electrician for Installation in Accordance With Local Building Codes: Machine **MUST Be Properly Grounded**.

ALWAYS Install Equipment in Work Area with Adequate Light and Space Away From Children and Visitors.

ONLY Operate on a Solid, Level, Non-Skid Surface.

NEVER Operate Without all Warning and Instruction Labels Attached.

1. Read this Manual thoroughly before installation and operation. **Do not** proceed with installation and operation if you have any questions or do not understand anything in this Manual. Contact your local Distributor, or BIRO first.
2. Install machine on a level, solid, non-skid surface in a well-lighted work area away from children and visitors.
3. Lock the casters in the fixed position before operating machine.
4. Electrical connection must be connected correctly and properly grounded. **INPUT VOLTAGE MUST MATCH** the step down transformer's input voltage. The internal connections must be changed in accordance with the circuit diagram. See Electrical Specifications.
5. Check BLADE ROTATION, the blade must cut down through the product. Single blade rotations can be achieved by pressing the "ONE STROKE" key. The direction of blade rotation may be changed by exchanging any two phase leads within the plug. **(CAUTION! Do not exchange the ground lead.)** This procedure should only be performed by a recognized BIRO representative or a certified electrician.
6. The BLADE must maintain a good sharp smooth edge. The blade is 5MM (.197") thick and must be the same for blade replacements. It is necessary to rotate the blade by hand to ensure proper clearance. This procedure must be performed on initial installation and with all blade replacements. Every time, when a blade has been replaced, it is necessary to turn at least one rotation of the blade by hand with the switch button "BRAKE RELEASE" pressed down and held. Open the blade door, the blade may be turned by hand into the most suitable assembly position, disassembly, removal of product scraps, cleaning, etc.
7. Operation, turn main switch on, 888 88/88 will appear on the display. If the blade door and lids are closed, the emergency stop is in the pulled out position and only the red light is illuminated on the keypad, only open one lid, (loading chamber or receiving chamber lid) briefly and close again, (control circuit is cleared for operation); NOTE: if all LED's are off, the loading chamber lid must be opened briefly and re-closed. This will activate the display to feature 00.0 releasing the machine operational.
8. Cut product must be laid with its straight side to the wall toward the front edge near the operator in the loading chamber and grip the product securely to product pusher assembly. Products with chine bone must be laid with its bone to the wall toward the front edge near the operator in the loading chamber and grip the product securely in the product pusher assembly.
9. Product in the loading chamber to be cut must always advance toward the sender and receiving eyes. The eyes are the red lens located in the loading chamber.
10. Product not filling the loading chamber width by 70% should use the side product deflector, Item No. PC103.

OPERATION



SHARP KNIFE BLADE TO AVOID SERIOUS PERSONAL INJURY

ONLY Properly Trained Personnel Over 18 Years of Age Should Use This Equipment.

ALWAYS Keep Hands and All Body Parts Clear of The Cutting Area.

DO NOT Tamper With, Bypass, Alter, or Modify This Equipment in Any Way From Its Original Condition.

ALWAYS Turn Off, Unplug From Power Source and Perform Lockout/Tagout Procedure to This Machine Before Cleaning, Servicing, or When Not In Use.

NEVER Leave Unattended While Operating.

NEVER Operate Without All Warning and Instruction Labels Attached.

A. KEYPAD OPERATION:

NOTE: The numbered buttons cannot be activated during the "ADVANCE" ⇐, during "RETURN" ⇒, during slicing operation or when any fault number is indicated, such as, (EXAMPLE: -2-).

NOTE: The NUMBERS can be entered as decimal or fractional, (EXAMPLE: 1.25 OR 1¼; .25 OR ¼).

KEY: "C" resets, or clears the function, erases display to 00.0. If canceling an operational key, press twice on the KEY "C". This clears all flashing LED's for a new operating function.

KEY: "DECIMAL POINT", resets the display to 00.0.

KEY: ⇐ "ADVANCE", once this key has been depressed, the product pusher assembly slides toward the blade end of the loading chamber. The product pusher assembly only advances while the "ADVANCE" key is depressed, releasing the key stops the movement of the product pusher assembly.

KEY: ⇒ "RETURN", once this key has been depressed, the product pusher assembly slides toward the right end of the loading chamber (the home position). The "RETURN" key functions with the initial key depression. The return function will stop when either the loading or receiving chamber lids are opened. Reclosing the lid will resume the function.

KEY: ○ "BLADE TURN (ONE STROKE)", depressing the key causes the blade to turn one full rotation.

KEY: ■ “START”, the “START” key will only function, if the blade door and chamber lids are closed and no fault number is present on the display.

The cutting process is started by depressing the number, decimal or fractional, desired for the product cut thickness. The display unit then will respond by flashing the LED related with THICKNESS. The operator will then press the “THICKNESS/COUNT” key to enter the desired thickness of cut.

Product should be ready in the loading chamber, then the operator shall press the “START” key. The product pusher assembly will advance toward the blade end. The sender and receiver eyes will sense product and start the cutting action.

If the product is started from the far right of the loading chamber (HOME POSITION) and the LAST CUT DISTRIBUTION “ON” key was depressed before the START key, the product will advance, activating the Automatic Calculation Mode which determines product length so slice thickness is optimized, and minimizing thickness of the last remaining slice. The new slice thickness appears in the display only if entered in decimal form number. LAST CUT DISTRIBUTION will function in fractional display, but will not show correction to fractional number. Optimized cutting is best achieved if the cut is One (1) inch or larger. Once the product has been sliced, the product pusher assembly will return to the initial position (HOME POSITION). The original set slice thickness will appear on the display. If product is not started from the home position and the LAST CUT DISTRIBUTION “ON” key was depressed, the remaining slice distribution is not activated and FAULT -6- will appear in the display. Depress the CLEAR “C” key, next depress the ⇨ RETURN key to move the product pusher assembly to the home position. Be sure the LAST CUT DISTRIBUTION key is on, depress the START key to resume the slicing process.

KEYS: THICKER and THINNER, depressing either key during the cutting operation will automatically increase or decrease the slice thickness by .06 or $\frac{1}{16}$ of an inch continuous cycle until the THICKER OR THINNER key is depressed again. Cutting will then continue with the last slice thickness which was entered into the display. After the last cut and the product pusher assembly has returned, the original slice thickness will again be displayed.

KEY: O “STOP”, depressing the key stops the product pusher assembly, stops the cutting operation with the blade in the home position, also stopping any remaining functions. If product remains in the loading chamber depress the ⇨ RETURN key. After product has returned to the home position, normal starting can continue, with any added program changes.

SLICE THICKNESS shall be entered from the keypad in either inches and/or decimal fractions or inches and/or fractional multiples of $\frac{1}{16}$ th inch. The display of whole inch units shall consist of 1 or 2 digits. The display of decimal fractions shall consist of 1 or 2 digits such that the total displayed digits is 3.

TO ENTER WHOLE INCHES press the whole inches on the keypad. The display shall respond by showing the entered number(s) to the left of the decimal point with the decimal point illuminated. Completion of whole inches entry is accomplished by entering a decimal point key on the numeric keypad, then entering a fractional value from the fraction keypad or by pressing a valid control key. Incorrect entries may be erased by pressing the CLEAR “C” key or by entering more digits which will cause the display to scroll to the left until the desired inch value is displayed.

SLICE COUNT shall be entered when required for program entry only. Slice counts from 1 to 99 are allowed. Fractional number(s) for slice counts are not allowed. Incorrect entries may be erased by pressing the CLEAR “C” key or by entering more digits which will cause the display to scroll to the left until the desired count is displayed.

LAST CUT DISTRIBUTION, MANUAL OPERATION (non-program state) LAST CUT DISTRIBUTION will cause the slice thickness entered from the keypad to be slightly adjusted before the slicing operation begins. This allows the product to be cut into equal pieces and eliminates waste at the final slice. Eliminating all waste can be achieved with a 1" cut slice or larger. This operation can be entered when the START key is pressed, the LAST CUT DISTRIBUTION LED is on and a slice thickness is shown on the display. NOTE: If the slice thickness is entered in a fraction number, the display will not show the adjusted slice thickness. Only if the fractional number is entered as a decimal equivalent will the display show the adjusted value.

KEYPAD DISPLAY consists of three digits to identify whole inches and decimal fractions and four digits arranged to allow fractional displays with 1 or 2 digit numerators and 1 or 2 digit denominators.

FOUR INDICATOR LAMPS (LED's) located below the display are for indicating that the emergency stop is pushed down and/or the door and/or lids are open or a warning condition exists, which must be corrected before normal operation may begin.

PROGRAM RECALL KEY When pressing the PROGRAM RECALL the unit will respond by clearing the display and flashing the LED associated with the PROGRAM RECALL key. The operator shall then enter a single digit number 1 to 9 to select the stored program for recall. The display unit will respond by extinguishing the indicator associated with the PROGRAM RECALL key. The display will show the program number as example – 1. NOTE: PROGRAM can be started or viewed at this point. Press the CLEAR “C” key before entering the program number will cause the display unit to return to its previous state.

PROGRAM VIEW KEY activates the stored automatic slicing program for different slice thicknesses in 1, 2, and/or 3 separate sections along the total length of the product being sliced. Pressing the PROGRAM VIEW KEY the keypad will respond by clearing the display and flashing the LED associated with the PROGRAM VIEW key. The operator shall enter a single digit number 1 to 7 to select the stored program for viewing. The keypad will respond by illuminating the LED associated with the PROGRAM VIEW and the THICKNESS LED. The display will show the slice thickness in the first section of the product in the same numerical units in which it was stored. The operator shall then press the PROGRAM VIEW key again to view the count value. The keypad will respond by extinguishing the THICKNESS LED and illuminating the LED associated with the COUNT. The display will show the slice count for the previous thickness value. The operator shall then press the PROGRAM VIEW key again to view the slice thickness in the middle section of the product. The keypad will extinguish the COUNT LED and illuminate the LED associated with the THICKNESS LED. The display will show the slice thickness for the middle section the same numerical units in which it was stored. NOTE: There is no count value for the middle section of the product.

The operator shall then press the PROGRAM VIEW key again to view the slice thickness at the trailing end of the product. If no thickness value exists for the trailing end of the product, the thickness will be the same value as the middle section of the product. Upon a stored program with a trailed end thickness value the keypad will respond by illuminating the LED associated with the THICKNESS. The display shall show the slice thickness for the trailing end of the product in the same numerical units in which it was stored. The operator shall then press the PROGRAM VIEW key again to view the slice count at the trailing end of the product. The keypad will respond by extinguishing the THICKNESS LED and illuminating the LED associated with the slice COUNT. The display will show the slice count for the trail end of program.

The next press on the PROGRAM VIEW key will repeat the same operator steps as stated.

TERMINATING THE PROGRAM VIEW, the operator shall press the CLEAR “C” key. This may be done at any time during program viewing process. The display unit will respond by returning to its previous state before the program viewing process.

B. MACHINE OPERATION FOR PROGRAMMING

INITIATING THE PROGRAM (ENTER key): Depressing the ENTER key the display will show “-----”. The operator shall enter a program number from 1 to 9 to select the program storage. The display unit will respond by flashing the LED associated with the PROGRAM ENTER key, flashing the LED associated with THICKNESS and clearing the display. The flashing LED prompts the operator for a thickness input.

ENTRY OF LEADING END SLICE THICKNESS: The operator shall enter the required thickness. Refer to the slice thickness section on page 5, once the thickness value is entered, the operator shall press the THICKNESS/COUNT key to enter the leading end thickness entry. The keypad unit shall respond by extinguishing the LED associated with THICKNESS, flashing the LED associated with COUNT, and clearing the display.

ENTRY OF LEADING END SLICE COUNT: The operator shall enter the slice COUNT. Refer to the slice count section on page 5, once the slice count value is entered, the operator shall press the THICKNESS/COUNT key to enter the leading end slice count entry. The keypad unit shall respond by flashing the LED associated with THICKNESS and clearing the display.

ENTRY OF MID-SECTION SLICE THICKNESS: The operator shall enter the required mid-section slice thickness. Once the mid-section slice thickness value is entered, the operator shall press the THICKNESS/COUNT key to enter the mid-section THICKNESS entry. The keypad unit shall respond by flashing the LED associated with THICKNESS, flashing the PROGRAM ENTER LED, and clearing the display.

OPTIONAL TRAILING END: At this point, the program entry may continue for the trailing end of the product. To enter the trailing end slicing, the operator shall enter the THICKNESS. Once the trailing end slice thickness value has been entered, the operator shall press the THICKNESS/COUNT key. The keypad unit shall respond by flashing the LED associated with the PROGRAM ENTER key, flashing the LED associated with COUNT, and clearing the display unit.

ENTRY TRAILING END SLICE COUNT: The operator shall enter the trailing end slice count. Once the trailing end slice count value has been entered the operator shall press the THICKNESS/COUNT key. The keypad unit shall respond by extinguishing the LED associated with the COUNT, flashing the LED associated with PROGRAM ENTER key, and the display unit shall show the program number as ---n, Example ---1.

FINISHING PROGRAM ENTRY: The operator shall press the PROGRAM ENTER key to indicate completion of the program. The keypad unit shall respond by extinguishing the LED associated with the PROGRAM ENTER key and return to the state it was in before program began.

OPTIONAL PROGRAM ENTRY WITH NO TRAILING END ENTRY: At the end of programming the mid-section slice thickness, it can be possible to save the entered program with no trailing end entry. This is accomplished by the PROGRAM ENTER key after completing the mid-section slice thickness entry. The keypad unit shall respond as described under FINISHING PROGRAM ENTRY.

KEYPAD

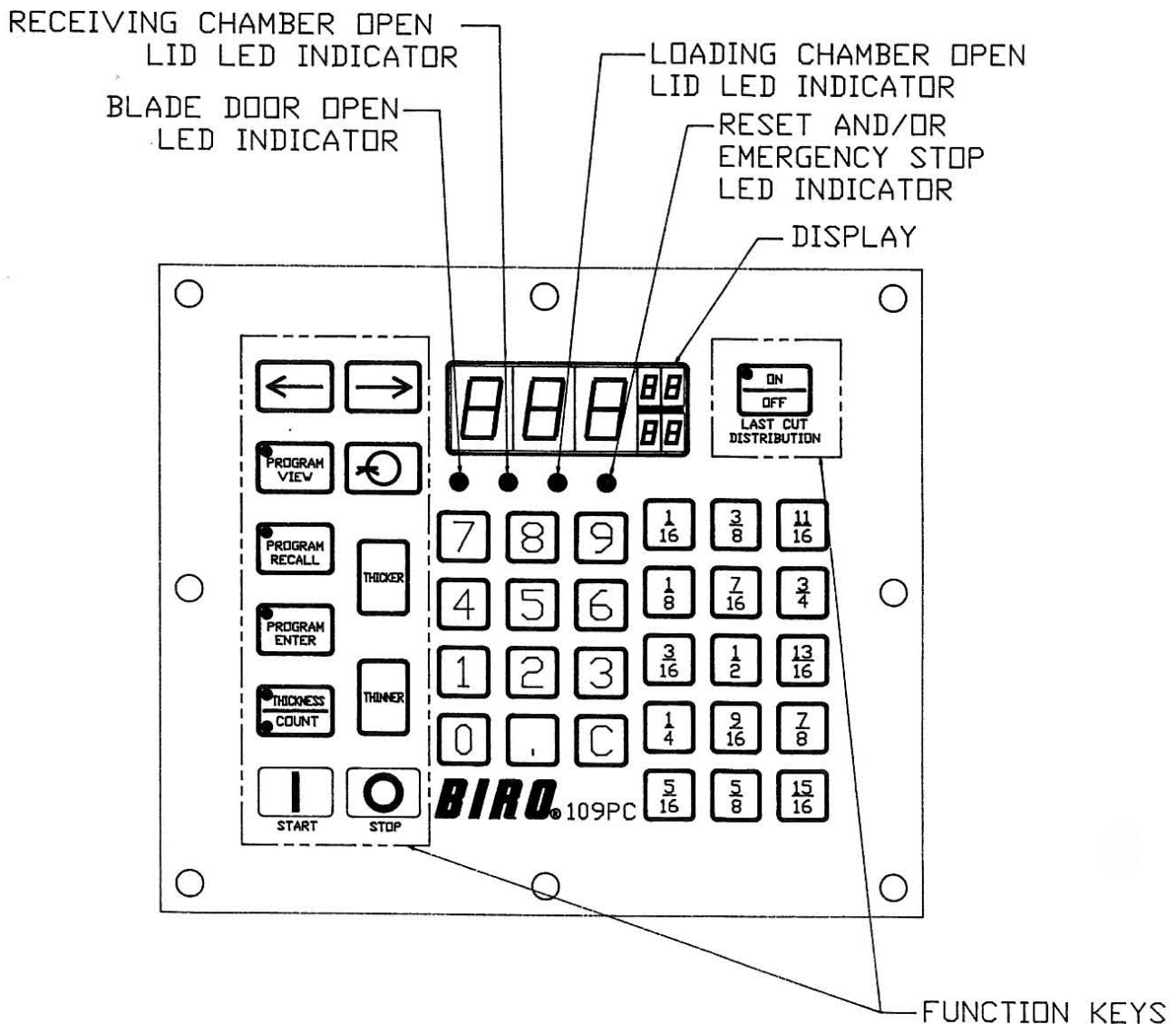

C. SYSTEM ERRORS:

SYSTEM ERRORS are identified by the fault codes displayed according to the type of system error as described below:

FAULT “-0-” A door and/or lid has been opened during the slicing operation. The slicing operation is stopped immediately, even in mid slice. Operation of unit will continue only after all lids and/or door has been closed and the **FAULT** has been acknowledged by pressing the **CLEAR “C”** key.

FAULT “-1-” The blade motor has overheated. The slicing operation should stop. The **FAULT** may be acknowledged by pressing the **CLEAR “C”** key, even if the motor is still overheated. Normal operation can continue after the motor and the electrical system have been checked. Continued operation in an overheated state will cause motor failure.

FAULT “-2-” The sender and/or receiver eye is blocked by an obstruction. Normal operation may continue only after the obstruction has been cleared from the eyes and the **FAULT** acknowledged by pressing the **CLEAR “C”** key.

FAULT “-3-” The blade position sensor has failed to respond, indicating a failure of the blade to rotate or a defective blade position sensor. Open the blade door and depress and hold the **BRAKE RELEASE** button, carefully rotate the blade clockwise to the blade starting position. Release the **BRAKE RELEASE** button, close the blade door. Normal operation may resume and the **FAULT** has been acknowledged by pressing the **CLEAR “C”** key.

FAULT “-4-” The cutting length in the loading chamber determined by the limit sensor(s) is smaller than the length determined by the software. Normal operation may resume only after the **HOME END POSITION** and/or the **BLADE END POSITION** sensor has the correct spacing and the fault has been acknowledged by pressing the **CLEAR “C”** key.

FAULT “-5-” Both **HOME END POSITION** and **BLADE END POSITION** limit sensors are activated at the same time. Normal operation may resume after the spacing between the limit sensors has been corrected or the limit sensors have been replaced and the fault has been acknowledged by pressing the **CLEAR “C”** key.

FAULT “-6-” The product pusher did not start in the **HOME END POSITION** when the **LAST CUT DISTRIBUTION** key was activated. Normal operation may resume after starting the product pusher from the **HOME END POSITION** or turn off the **LAST CUT DISTRIBUTION** key and the fault has been acknowledged by pressing the **CLEAR “C”** key.

FAULT “-10-” If the operator attempts to recall a program which has not been saved. Normal operation may continue after the fault has been acknowledged by pressing the **CLEAR “C”** key.

FAULT “-11-” The product is not long enough for the chosen program. Normal operation may resume after choosing a different program and/or different product length and the fault has been acknowledged by pressing the **CLEAR “C”** key.

CLEANING



SHARP KNIFE BLADE **TO AVOID SERIOUS PERSONAL INJURY**

ALWAYS Turn Off, Unplug From Power Source and Perform Lockout/Tagout Procedure to This Machine **BEFORE** Cleaning or Servicing.

ONLY Use Recommended Cleaning Equipment, Materials and Procedures.

NEVER Spray Water or Other Liquid Substances Directly at Motor, Power Switch or any Other Electrical Components.

ALWAYS Thoroughly Clean Equipment at Least Daily.

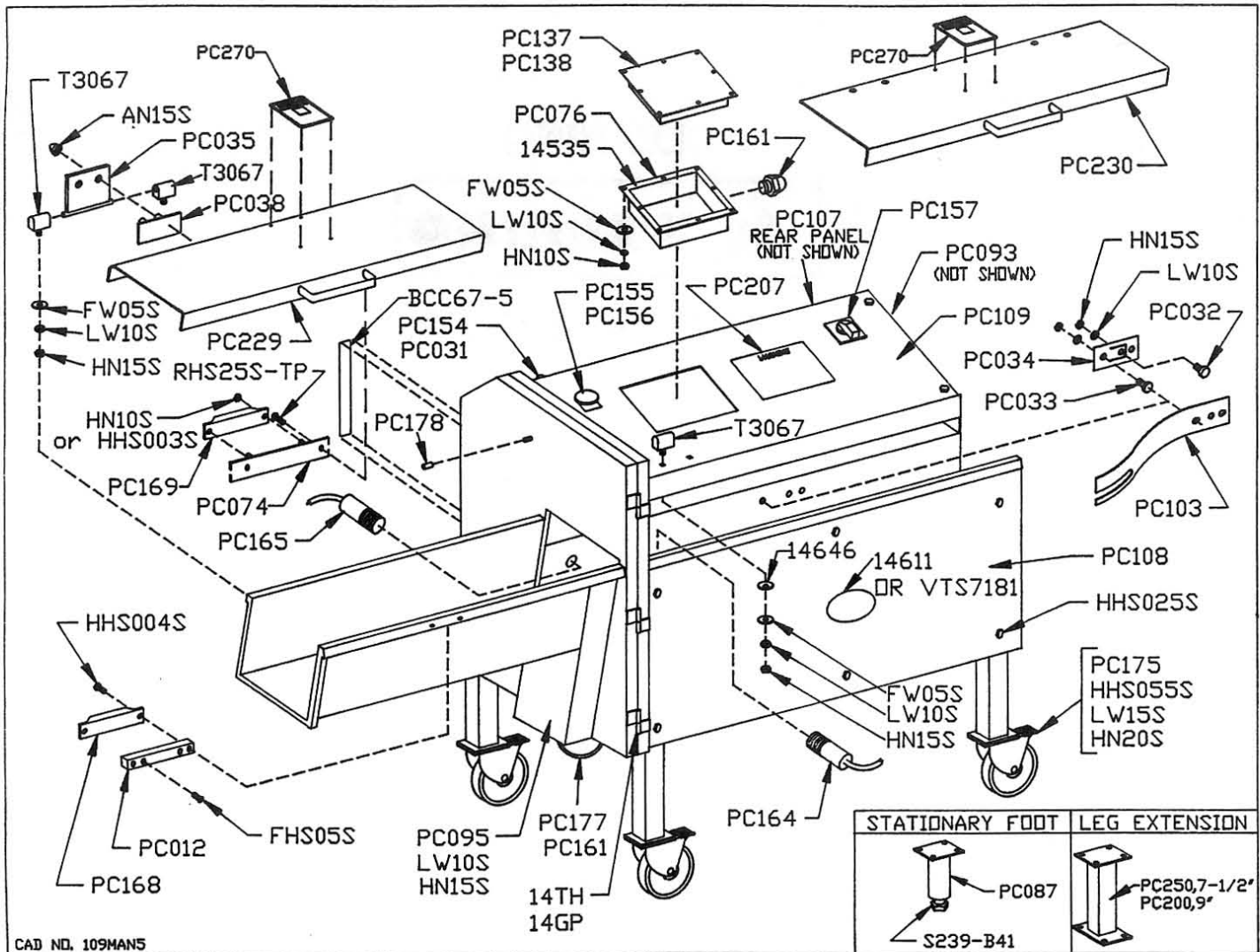

CAD NO. 109MAN5

Item No.	Description
AN15S	Acorn nut, 1/4-20, SS
BCC67-5	Decal "DANGER EXPOSED BLADE"
FHS05S	Flat head screw, 8-32 x 5/16, SS
FW05S	Flat washer 1/4, SS
HHS003S	Hex head screw, 8-32 x 1/4, SS
HHS004S	Hex head screw, 8-32 x 3/8, SS
HHS025S	Hex head screw, 1/4-20 x 1/2, SS
HHS055S	Hex head screw, 5/16-18 x 3/4, SS
HN10S	Hex nut, 10-32, SS
HN15S	Hex nut, 1/4-20, SS
HN20S	Hex nut, 5/16-18, SS
LW10S	Lockwasher, 1/4, SS
LW15S	Lockwasher, 5/16, SS
PC012	Tray safety switch spacer
PC031	Legend plate, "BRAKE RELEASE"
PC032	Product deflector release pin
PC033	Product deflector keyhole stud
PC034	Product pusher fastener plate
PC035	Chamber cover hinge & hinge pin
PC038	Chamber cover hinge connecting plate
PC074	Chamber cover handle mounting plate
PC076	Keypad assembly enclosure
PC087	Optional stationary foot
PC093	Rear right hand side panel
PC095	Receiving chamber support bracket
PC103	Side product deflector
PC107	Rear panel
PC108	Front panel
PC109	Top panel
PC137	Display board assembly w/keypad, Std.
PC138	Display board assembly w/keypad, Metric
PC154	Brake release switch

Item No.	Description
PC155	Emergency stop switch, push-pull
PC156	Legend plate "EMERGENCY STOP"
PC157	Main power switch
PC161	Strain relief fitting, 7/8
PC164	Front sender eye
PC165	Rear receiver eye
PC168	Loading & receiving chamber switch
PC169	Loading & receiving chamber switch magnet
PC175	Swivel castor w/lock
PC177	Blade door wire race
PC178	Chamber cover bumper
PC200	Extension leg, 9"
PC207	Warning & Operating label
PC229	Receiving chamber cover assembly
PC230	Loading chamber cover assembly
PC250	Leg extension, 7 1/2"
PC270	Warning label "SHARP KNIFE BLADE"
RHS25S-TP	Round head screw, 1/4-20 x 3/4, tamper proof, SS
S239-B41	Hex adjustable leg, 7/8-9 x 3
T3067	Hinge
14GP	Hinge pin, 1 1/2"
14TH	Hinge
14535	Foam tape gasket, per foot
14611	BIRO World decal, DNS
14646	Disc spring
42MC-656	Decal, "Wired for 208 volts"
42MC-658	Decal, "Wired for 230 volts"
42MC-660	Decal, "Wired for 380 volts"
42MC-662	Decal, "Wired for 440 volts"
653PS	Warning label, English
653SP	Warning label, Spanish

BLADE SHAFT ASSEMBLY

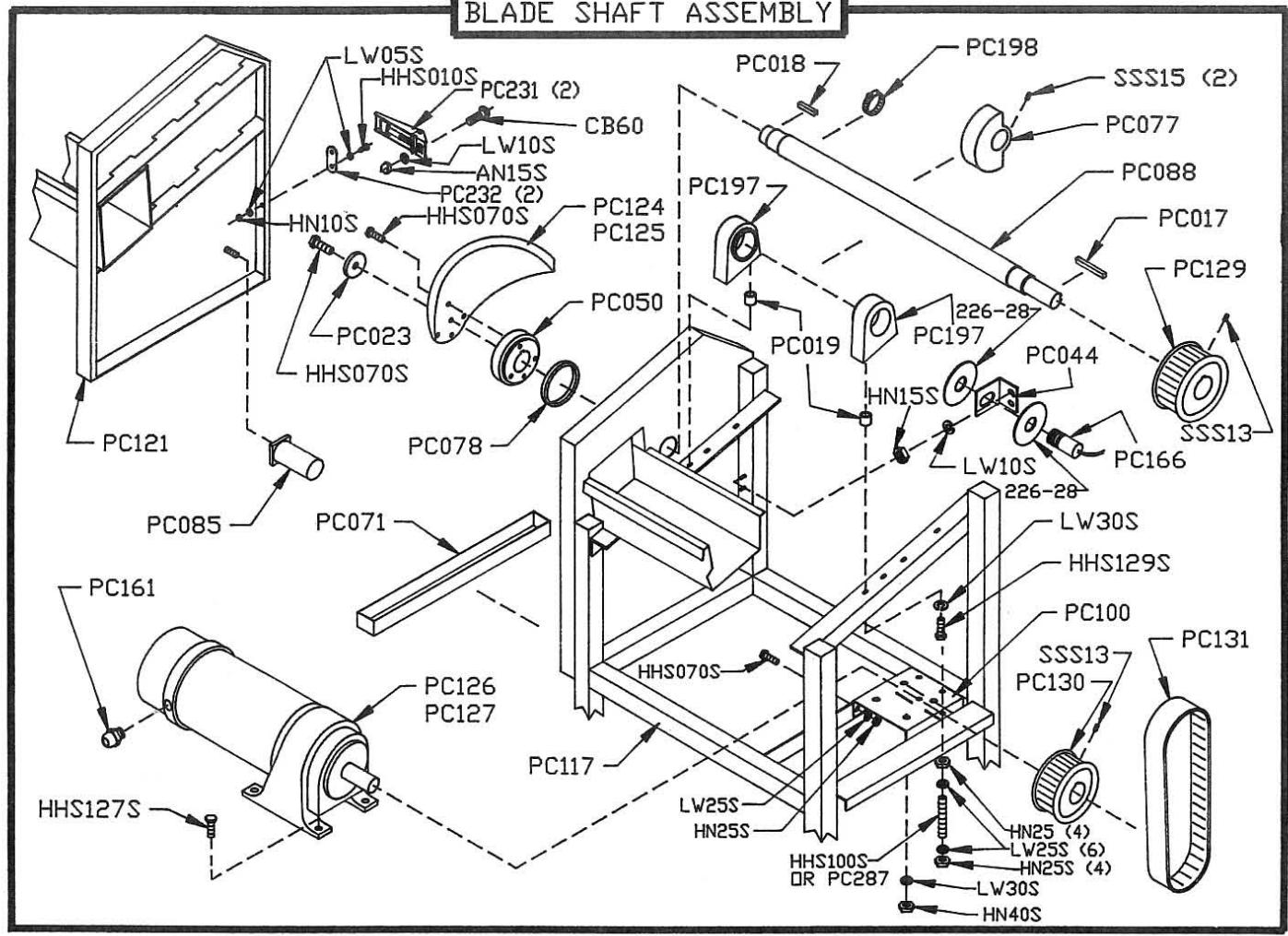

Item No.	Description	Item No.	Description
AN15S	Acorn nut, 1/4-20, SS	PC085	Blade door magnet housing
CB60	Carriage bolt, 1/4-20 x 1/2	PC088	Blade shaft
HHS010S	Hex head screw, 10-32 x 3/8, SS	PC100	Gear-brakemotor base plate
HHS070S	Hex head screw, 3/8-16 x 1, SS	PC117	Frame, NSS
HHS100S	Hex head screw, 3/8-16 x 6, SS	PC121	Left hand door & receiving chamber
HHS127S	Hex head screw, 1/2-13 x 2 1/2, SS	PC124	Smooth blade
HHS129S	Hex head screw, 1/2-13 x 2, SS	PC125	Serrated blade
HN10S	Hex nut, 10-32, SS	PC126	Gear-brakemotor, 3HP, 230/415-460-50/60-3
HN15S	Hex nut, 1/4-20, SS	PC127	Gear-brakemotor, 3HP, 220/380-50-3
HN25	Hex nut, 3/8-16 heavy	PC129	HTD pulley, upper 60HZ, lower 50HZ
HN25S	Hex nut, 3/8-16 heavy, SS	PC130	HTD pulley, lower 60HZ, upper 50HZ
HN40S	Hex nut, 1/2-13 light jam, SS	PC131	HTD belt, 1000-8M-50
LW05S	Lockwasher, #10, SS	PC161	Strain relief fitting, 7/8
LW10S	Lockwasher, 1/4, SS	PC166	Blade door safety switch
LW25S	Lockwasher, 3/8 heavy, SS	PC197	Pillow block
LW30S	Lockwasher, 1/2, SS	PC198	Hose clamp
PC017	Key, sheave blade shaft	PC231	Door latch assembly
PC018	Key, blade mounting plate	PC232	Door latch keeper assembly
PC019	Pillow block spacer	PC287	Motor adjusting stud
PC023	Blade mounting plate cap	SSS13	Set screw, 1/4-20 x 3/8, cup point
PC044	Proximity switch blade door mount	SSS15	Set screw, 5/16-18 x 5/16, cup point
PC050	Blade mounting plate	225-3	Conduit connector, 45 deg.
PC071	Scrap tray	226-28	Washer, 1 1/2 x 2 7/32, SS
PC077	Knife shaft counterweights	241-LN	Connector locknut
PC078	Blade shaft seal		

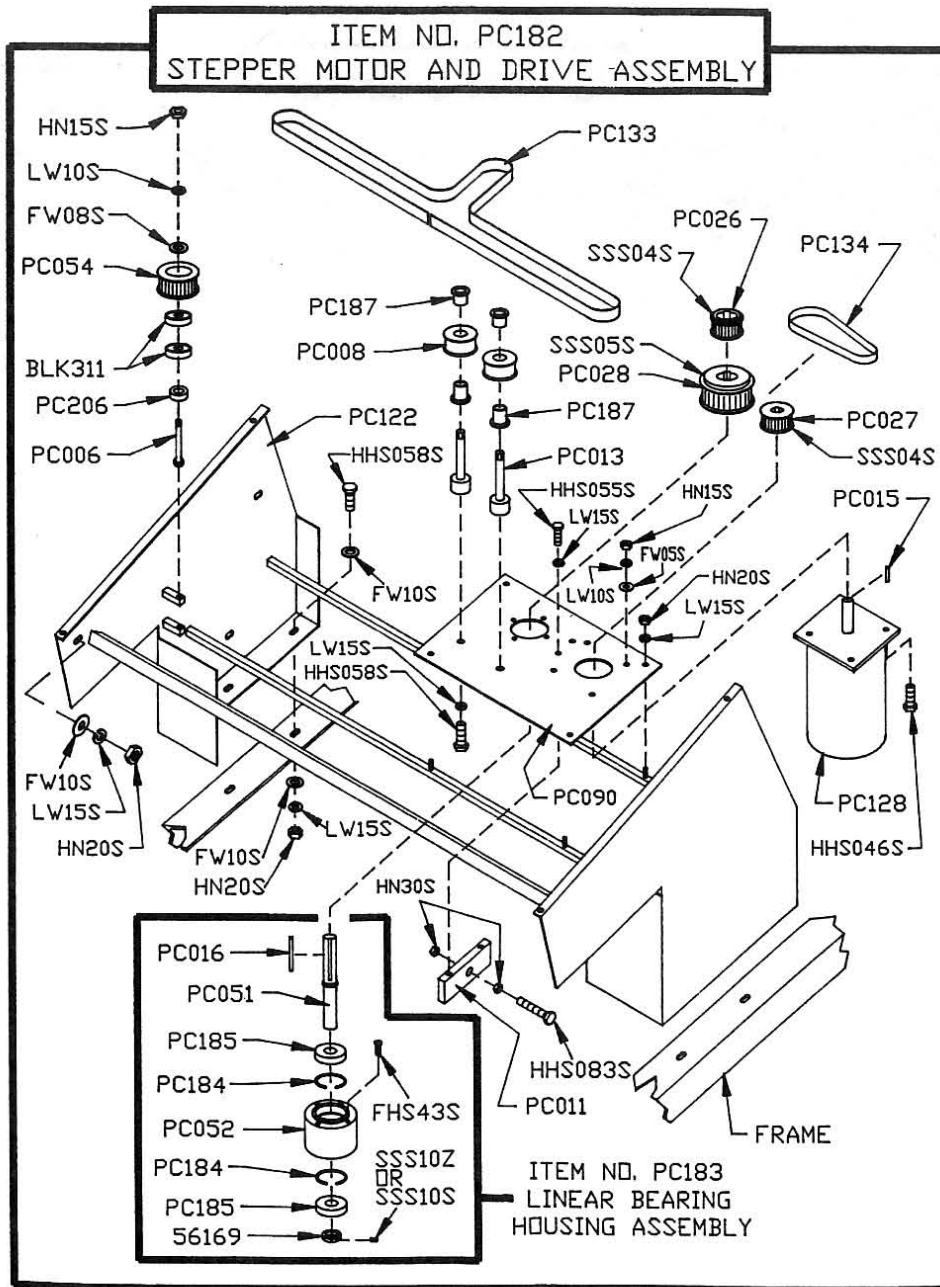

Item No.	Description	Item No.	Description
BLK311	Bearing, 9mm	PC027	Driving timing pulley, 20 tooth
FHS43S	Flat head screw, $\frac{5}{16}$ -18 \times $\frac{1}{2}$, SS	PC028	Driven timing pulley, 40 tooth
FW05S	Flat washer, $\frac{1}{4}$, SS	PC051	Linear drive reducer shaft
FW08S	Flat washer $\frac{3}{8}$, SS	PC052	Linear drive bearing housing
FW10S	Flat washer, $\frac{5}{16}$, SS	PC054	Driven timing pulley, 30 groove
HHS046S	Hex head screw, $\frac{1}{4}$ -20 \times 1, SS	PC090	Linear drive mounting plate
HHS055S	Hex head screw, $\frac{5}{16}$ -18 \times $\frac{3}{4}$, SS	PC122	Linear drive frame
HHS058S	Hex head screw, $\frac{5}{16}$ -18 \times $\frac{7}{8}$, SS	PC128	Stepper motor, 8 amp
HHS083S	Hex head screw, $\frac{3}{8}$ -16 \times $1\frac{3}{4}$, SS	PC133	Linear timing belt, 25T5/50M \times 87- $\frac{1}{4}$ "
HN15S	Hex nut, $\frac{1}{4}$ -20, SS	PC134	Timing belt, 25T5/480 \times 7 $\frac{1}{4}$ "
HN20S	Hex nut, $\frac{5}{16}$ -18, SS	PC182	Stepper motor and drive assembly
HN25S	Hex nut, $\frac{3}{8}$ -16 heavy, SS	PC183	Linear bearing housing assembly
LW10S	Lockwasher, $\frac{1}{4}$, SS	PC184	Retaining ring
LW15S	Lockwasher, $\frac{5}{16}$ heavy, SS	PC185	Bearing, 47mm \times 20 mm bore
PC006	Driven timing pulley shaft	PC187	Driven timing pulley flange bushing
PC008	Timing belt idler pulley	PC206	Driven timing pulley spacer
PC011	Tension mount	SSS04S	Set screw, 10-24 \times $\frac{1}{4}$ cone point, SS
PC013	Timing belt idler shaft	SSS05S	Set screw, 10-24 \times $\frac{3}{8}$ cup point, SS
PC015	Stepper motor key	SSS10S	Set screw, $\frac{1}{4}$ -20 \times $\frac{1}{4}$ cup point, SS
PC016	Reducer shaft key	SSS10Z	Set screw, $\frac{1}{4}$ -20 \times $\frac{1}{4}$ cup point, zinc
PC026	Driven timing pulley, 30 tooth	56169	Shaft collar

ITEM NO. PC195
PRODUCT PUSHER ASSEMBLY

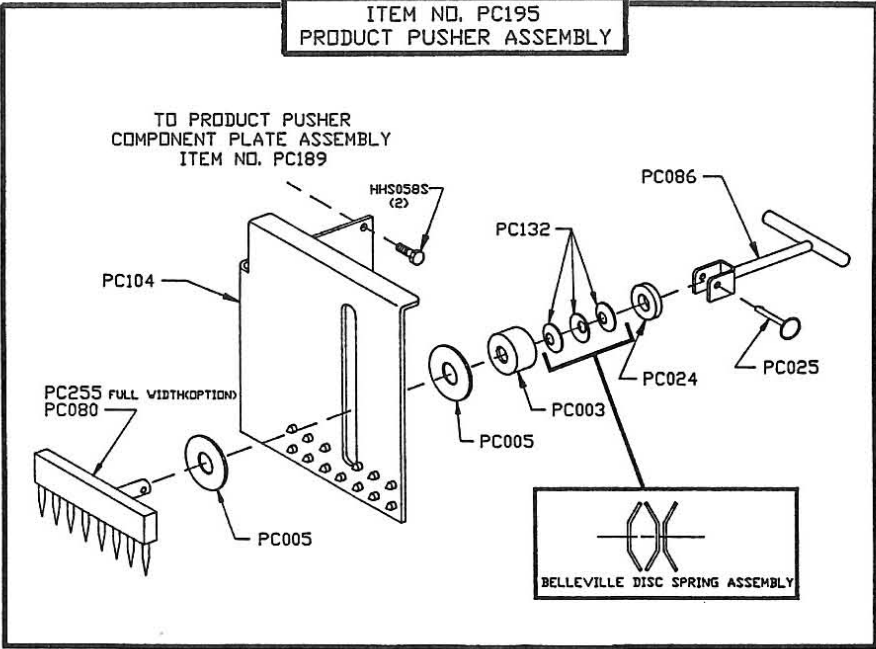

Item No.	Description
HHS058S	Hex head screw, $\frac{5}{16}$ -18 x $\frac{7}{8}$, SS
PC003	Spring housing
PC005	Slide washer
PC024	Thrust washer
PC025	Faspin
PC080	Standard gripper
PC086	Handle
PC104	Product pusher
PC132	Belleville disc spring
PC189	Product pusher component plate
PC195	Product pusher assembly
PC255	Optional gripper, full width

ITEM NO. PC269
PRODUCT PUSHER ASSEMBLY,
CLAW SPRING TYPE

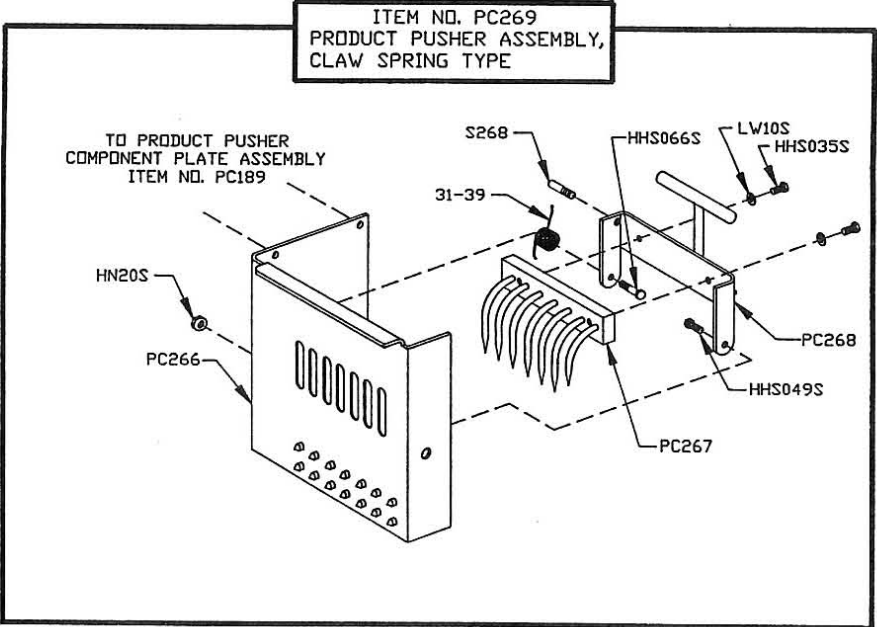

Item No.	Description
HHS035S	Hex head screw, $\frac{1}{4}$ -20 x $\frac{5}{8}$, SS
HHS049S	Hex head screw, $\frac{5}{16}$ -18 x $\frac{1}{2}$, SS
HHS066S	Hex head screw, $\frac{5}{16}$ -18 x 2, SS
HN20S	Hex nut, $\frac{5}{16}$ -18, SS
LW10S	Lockwasher, $\frac{1}{4}$, SS
PC266	Product pusher weldment, NSS
PCC267	Claw attachment
PC268	Handle weldment, NSS
PC269	Product pusher assembly, claw spring style
S268	Headless screw
31-39	Torsion spring

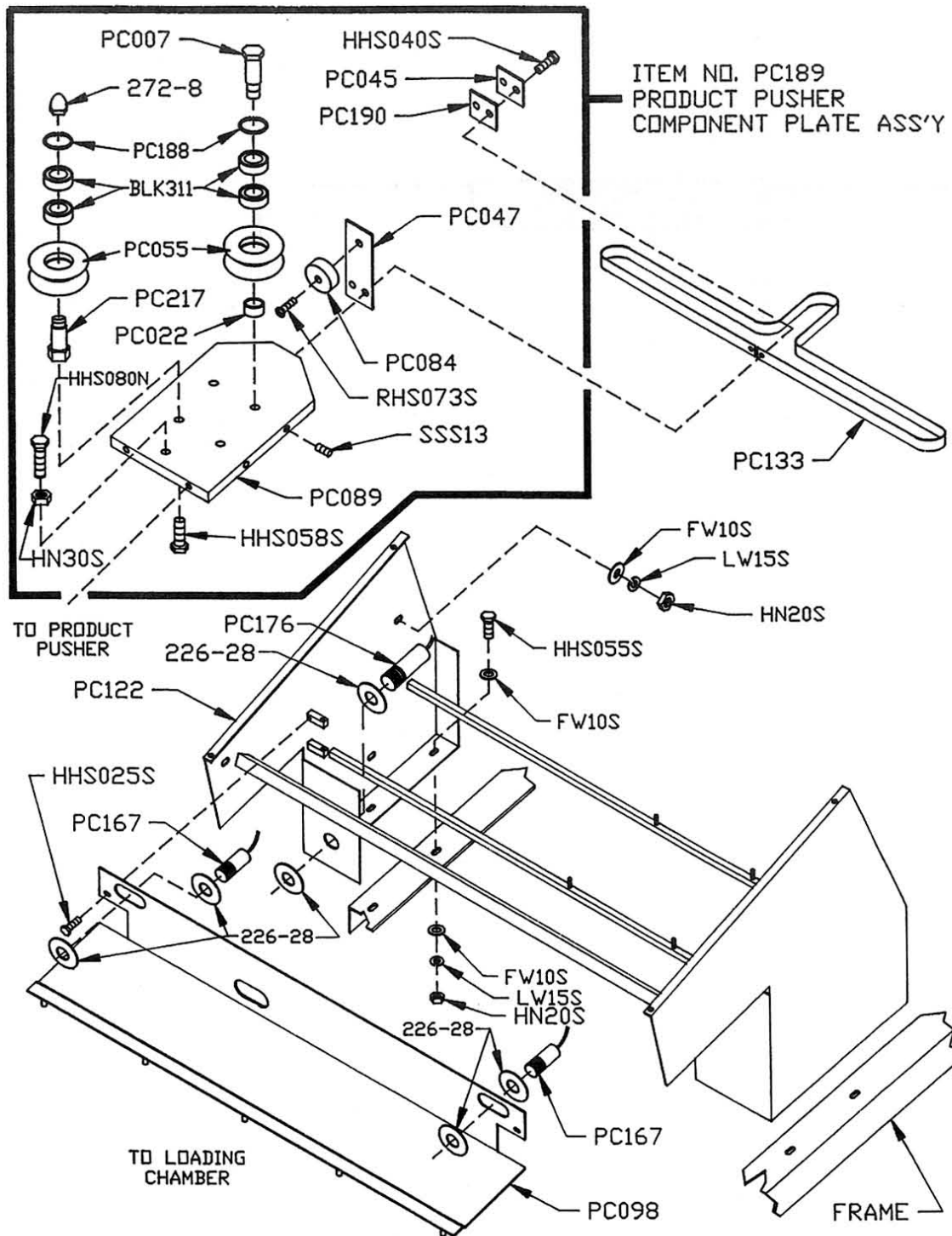

Item No.	Description
BLK311	Bearing, 9mm
FW10S	Flat washer, $\frac{5}{16}$, SS
HHS025S	Hex head screw, $\frac{1}{4}$ -20 \times $\frac{1}{2}$, SS
HHS040S	Hex head screw, $\frac{1}{4}$ -20 \times $\frac{3}{4}$, SS
HHS055S	Hex head screw, $\frac{5}{16}$ -18 \times $\frac{3}{4}$, SS
HHS058S	Hex head screw, $\frac{5}{16}$ -18 \times $\frac{7}{8}$, SS
HHS080N	Hex head screw, $\frac{3}{8}$ -16 \times $1\frac{1}{2}$
HN20S	Hex nut, $\frac{5}{16}$ -18, SS
HN30S	Hex nut, $\frac{3}{8}$ -16 light jam, SS
LW10S	Lockwasher, $\frac{1}{4}$, SS
LW15S	Lockwasher, $\frac{5}{16}$, SS
PC007	Bearing shaft
PC022	Product pusher component plate spacer
PC045	Belt clamping plate
PC047	Magnet holder

Item No.	Description
PC055	Roller
PC084	South pole (green) magnet
PC089	Component plate
PC098	Linear drive splash guard
PC122	Linear drive frame
PC133	Linear timing belt, 25T5/50M \times 87 $\frac{1}{4}$ "
PC167	Position switch
PC176	Tubular proximity switch, blade shaft
PC188	Retaining ring, IRR 3001-X102-SS2
PC189	Product pusher component plate assembly
PC190	Connecting belt
PC217	Front bearing shaft
RHS073S	Round head screw, 8-32 \times $\frac{1}{2}$, SS
SSS13	Set screw, $\frac{1}{4}$ -20 \times $\frac{3}{8}$ cup point
226-28	Washer, $1\frac{1}{2}$ \times 2 $\frac{7}{32}$, SS
272-8	Cap nut, $\frac{5}{16}$ -18, low crown

CONTROL BOX & COVER ASSEMBLY

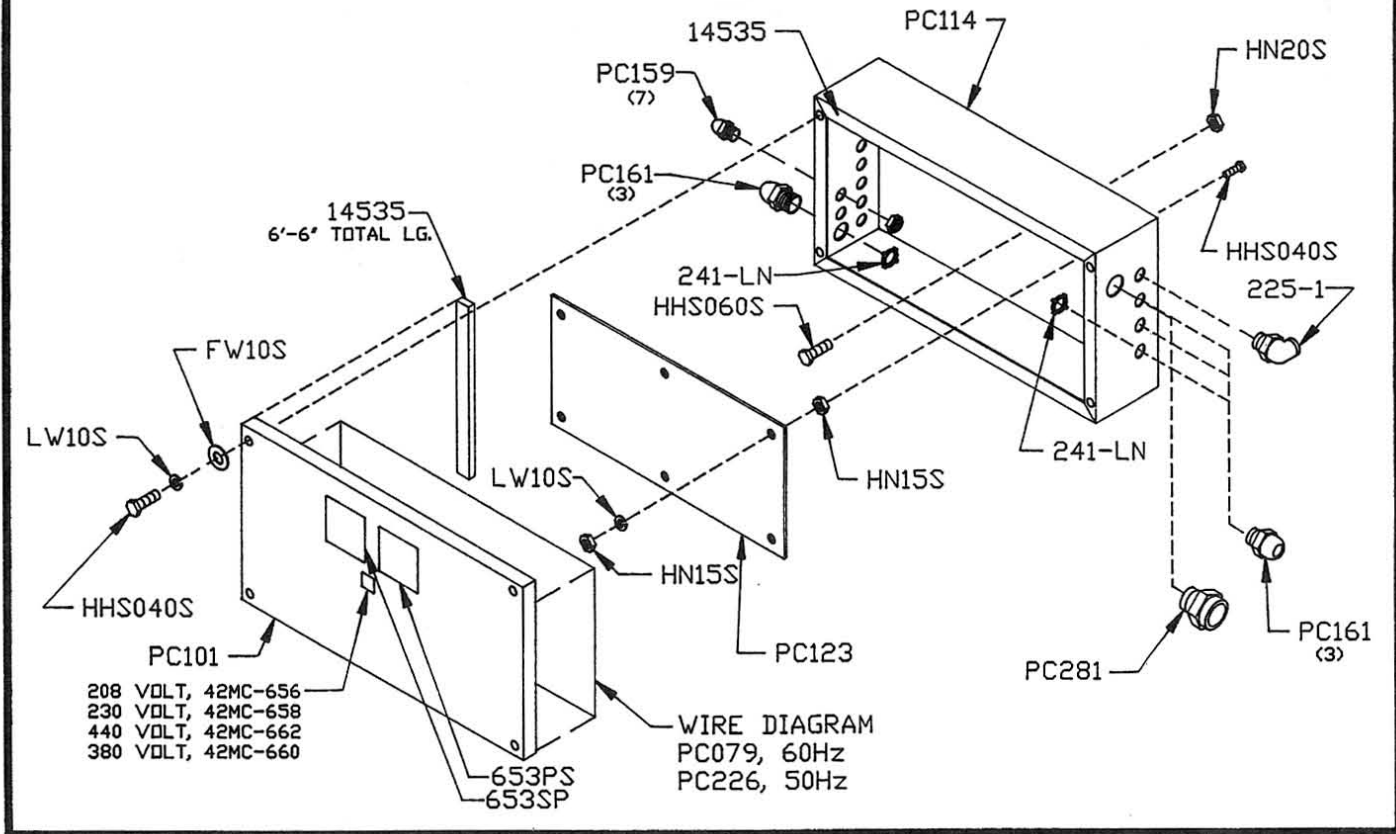

Item No.

FW10S
HHS040S
HHS060S
HN15S
HN20S
LW10S
PC079
PC101
PC114
PC123
PC159

Description

Flat washer, 5/16, SS
Hex head screw, 1/4-20 x 3/4, SS
Hex head screw, 5/16-18 x 1, SS
Hex nut, 1/4-20, SS
Hex nut, 5/16-18, SS
Lockwasher, 1/4, SS
Wiring diagram, 60 HZ
Control box cover
Control box
Component plate
Strain relief fitting, 1/2"

Item No.

PC161
PC226
PC281
14535
225-1
241-LN
42MC-656
42MC-658
42MC-660
42MC-662
653PS
653SP

Description

Strain relief fitting, 7/8"
Wiring diagram, 50 HZ
Strain relief, 3/4
Foam tape gasket, per foot
Conduit connector, 90 deg. WT
Connector lock nut
Decal, "Wired for 208 volts"
Decal, "Wired for 230 volts"
Decal, "Wired for 380 volts"
Decal, "Wired for 440 volts"
Warning label, English
Warning label, Spanish

ITEM NO. PC202
ELECTRICAL COMPONENTS ASSEMBLY
208-230-460V/60HZ/3PH

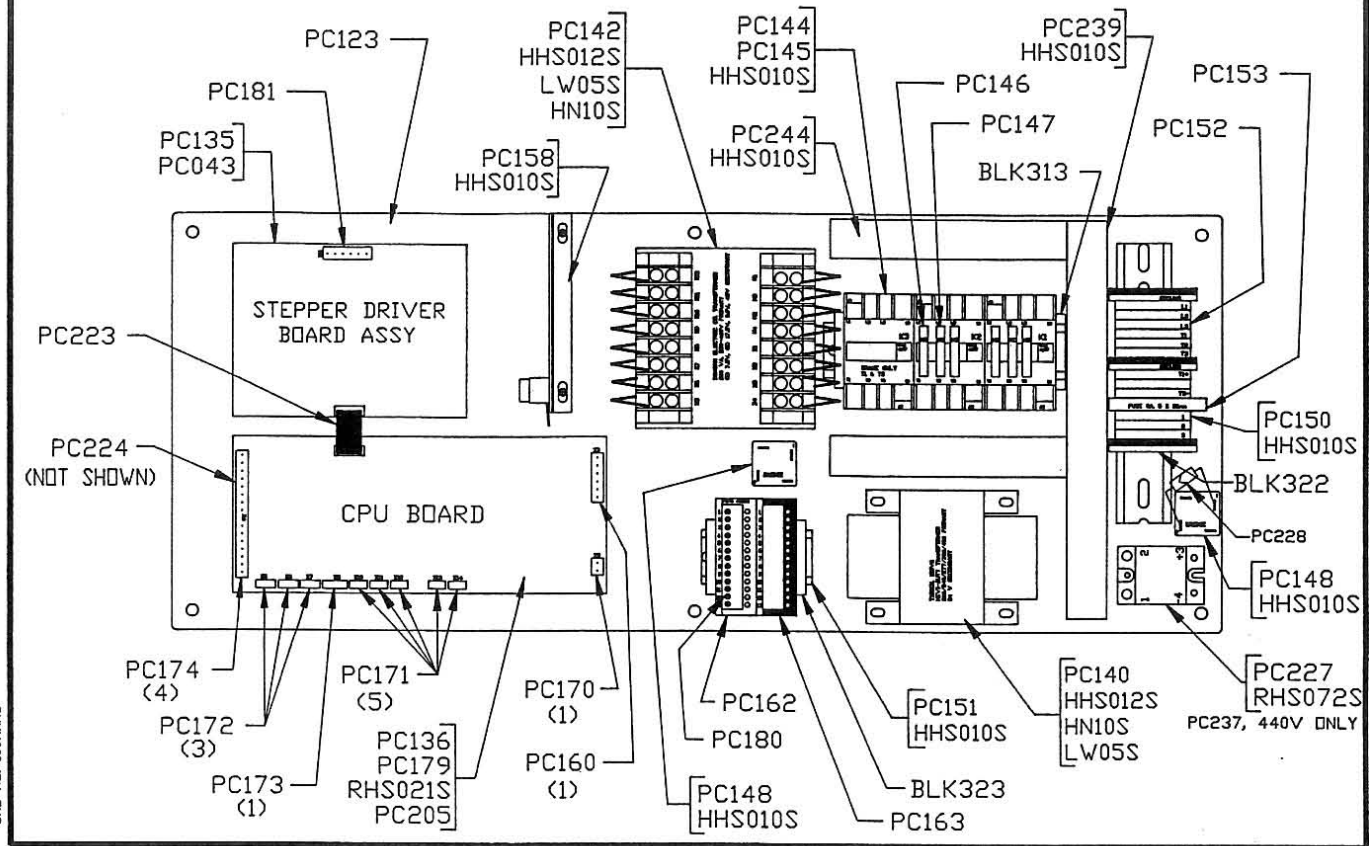

CAD NO. 1059AN6

Item No.	Description
BLK313	Din rail, 6" long
BLK322	Ground block
BLK323	End barrier
HHS010S	Hex head screw, 10-32 x 3/8, SS
HHS012S	Hex head screw, 10-32 x 1/2, SS
HN10S	Hex nut, 10-32, SS
LW05S	Lockwasher, #10, SS
PC043	Driver board bracket
PC123	Component plate
PC135	Driver board assembly
PC136	CPU board
PC140	Transformer, 208/240/277/380/480V to 24V, 60HZ
PC142	Multi-tap transformer, 208/230/460, 60HZ
PC144	Contact, SP17.10-GO, 24 volt
PC145	Suppressor, 24-48 VAC
PC146	Auxiliary contact, N.O., HS17.10
PC147	Auxiliary contact, N.C., HS17.01
PC148	Bridge, 48V-80V
PC150	Din rail, 7" long
PC151	Din rail, 2 3/4" long
PC152	Terminal
PC153	Fuse clip

Item No.	Description
PC158	Heater, 24V, 100W, w/thermostat
PC160	6 pin connector, female
PC162	Central control unit
PC163	Opto switching amplifier
PC170	2 pin connector, female
PC171	3 pin connector, female
PC172	4 pin connector, female
PC173	5 pin connector, female
PC174	10 pin connector, female
PC179	CPU stand off
PC180	Terminal pin
PC181	6 pin connector
PC202	Electrical components assembly, 60HZ
PC205	#6 star washer, SS
PC223	Flat ribbon cable
PC224	Cable assembly for display
PC227	Relay, SSRT 3-32VDC input, 120/240 out
PC228	Capacitor, 100uF, 50V
PC237	Solid state relay, 3-32VDC in, 480VAC out
PC239	Wire raceway, 10" long
PC244	Wire raceway, 6" long
RHS021S	Round head screw, 6-32 x 1/2, SS
RHS072S	Round head screw, 8-32 x 3/8, SS

T1 & T2 TRANSFORMER WIRING 208/220/230/240 VOLTS

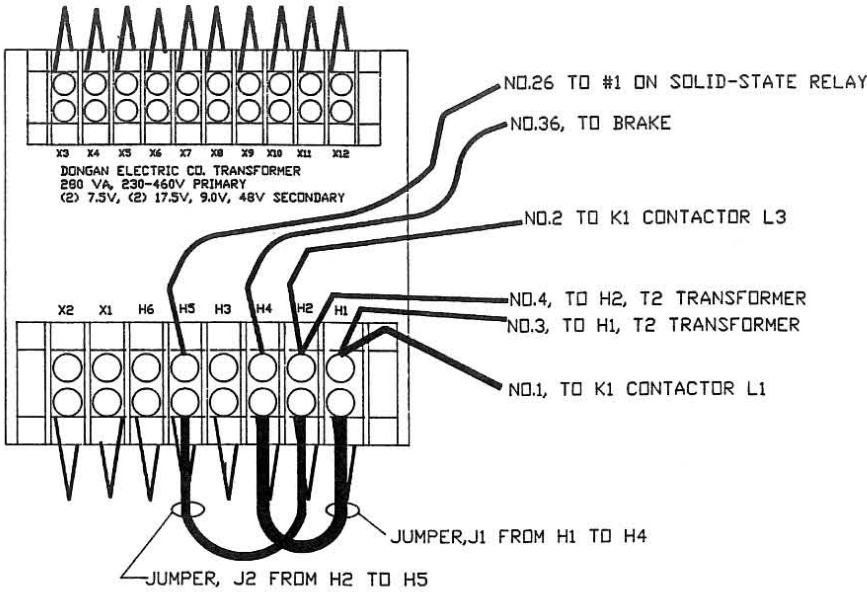

T1 TRANSFORMER
FOR A 208 VOLTAGE

T1 TRANSFORMER
FOR A 220,230 OR
240 VOLTAGE

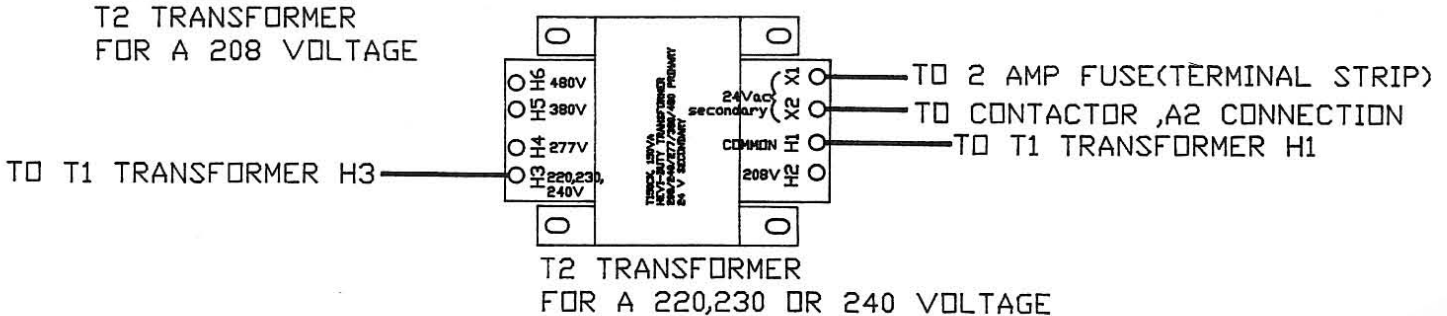
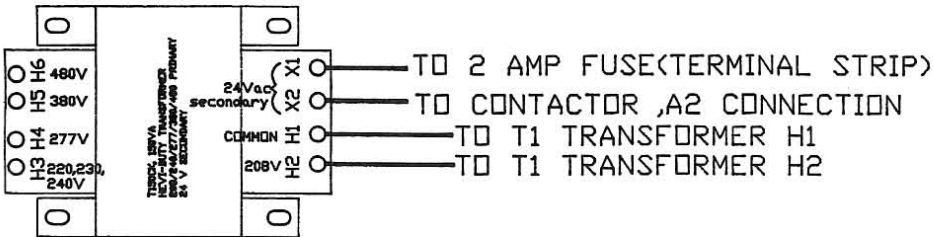
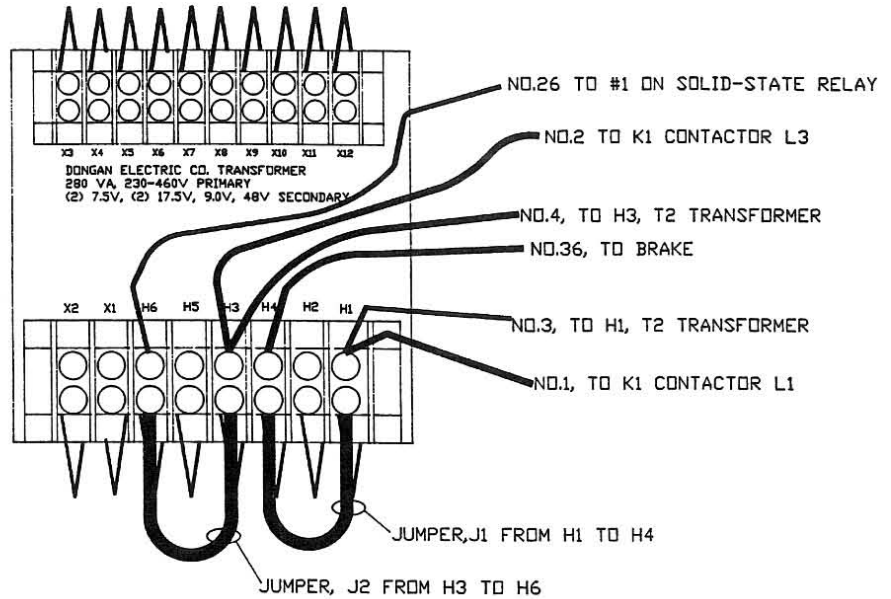

T1 & T2 TRANSFORMER WIRING 440/460/480 VOLTS

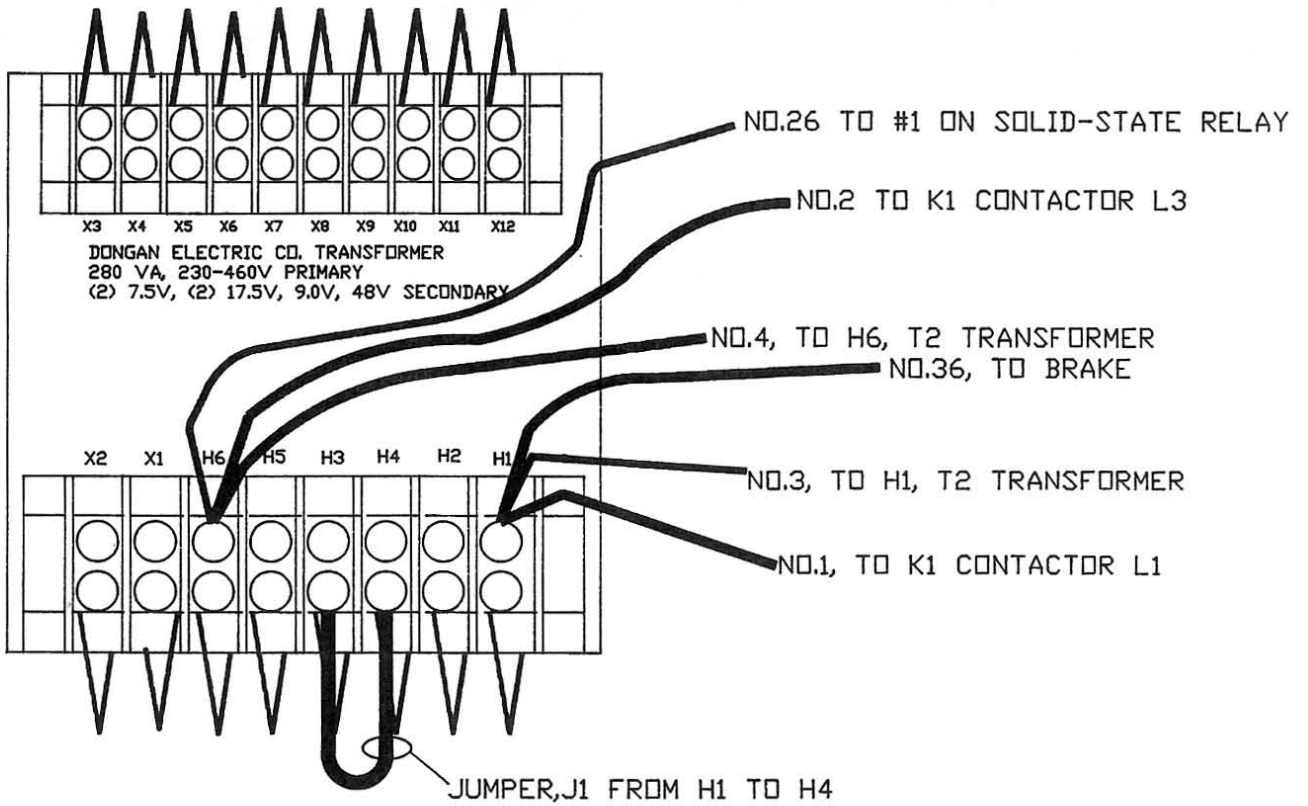

T1 TRANSFORMER
FOR A 440,460, OR 480 VOLTAGE

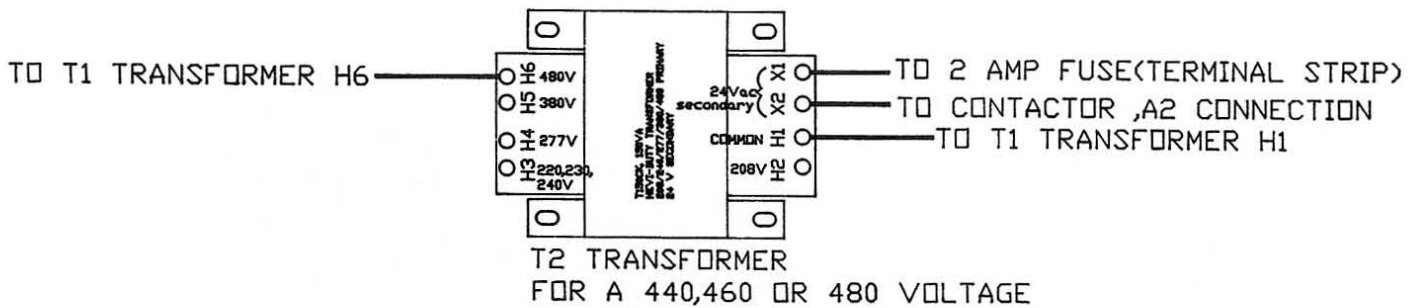

ITEM NO. PC204
ELECTRICAL COMPONENTS ASSEMBLY
380-415V/50HZ/3PH

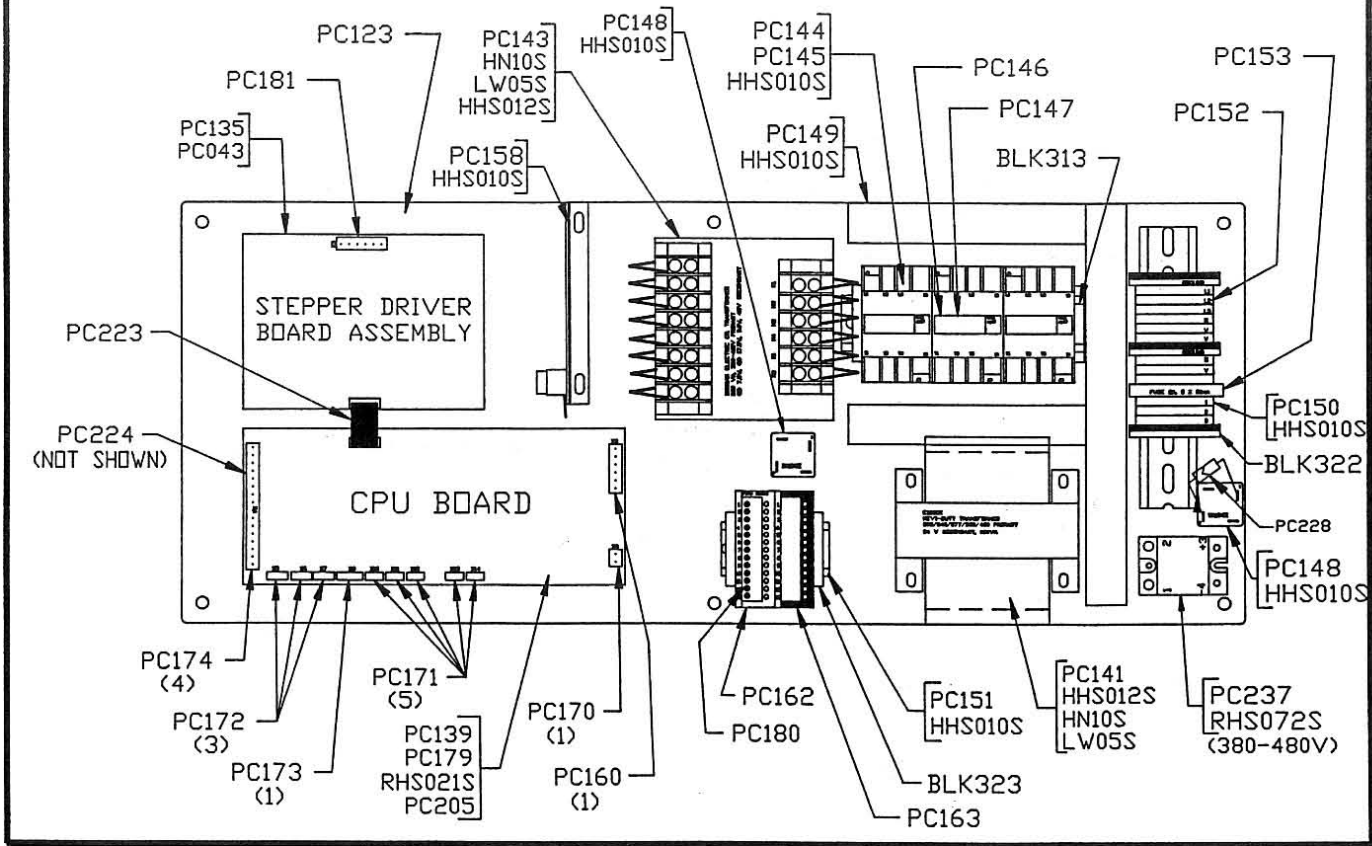

Item No.	Description
BLK313	Din rail, 6" long
BLK322	Ground block
BLK323	End barrier
HHS010S	Hex head screw, 10-32 x 3/8, SS
HHS012S	Hex head screw, 10-32 x 1/2, SS
HN10S	Hex nut, 10-32, SS
LW05S	Lockwasher, #10, SS
PC043	Driver board bracket
PC123	Component plate
PC135	Driver board assembly
PC139	CPU board, metric
PC141	Transformer, 380/415V to 24V, 50HZ
PC143	Multi-tap transformer, 380/415, 50HZ
PC144	Contactor, SP17.10-G0, 24 volt
PC145	Suppressor, 24-48 VAC
PC146	Auxiliary contact, N.O., HS17.10
PC147	Auxiliary contact, N.C., HS17.01
PC148	Bridge, 48V-80V
PC150	Din rail, 7" long
PC151	Din rail, 2 3/4" long
PC152	Terminal
PC153	Fuse clip

Item No.	Description
PC158	Heater, 24V, 100W, w/thermostat
PC160	6 pin connector, female
PC162	Central control unit
PC163	Opto switching amplifier
PC170	2 pin connector, female
PC171	3 pin connector, female
PC172	4 pin connector, female
PC173	5 pin connector, female
PC174	10 pin connector, female
PC179	CPU stand off
PC180	Terminal pin
PC181	6 pin connector
PC204	Electrical components assembly, 50HZ
PC205	#6 star washer, SS
PC223	Flat ribbon cable
PC224	Cable assembly for display
PC227	Relay, SSRT 3-32VDC input, 120/240 out
PC228	Capacitor, 100uF, 50V
PC237	Solid state relay, 3-32VDC in, 480VAC out
PC239	Wire raceway, 10" long
PC244	Wire raceway, 6" long
RHS021S	Round head screw, 6-32 x 1/2, SS
RHS072S	Round head screw, 8-32 x 3/8, SS

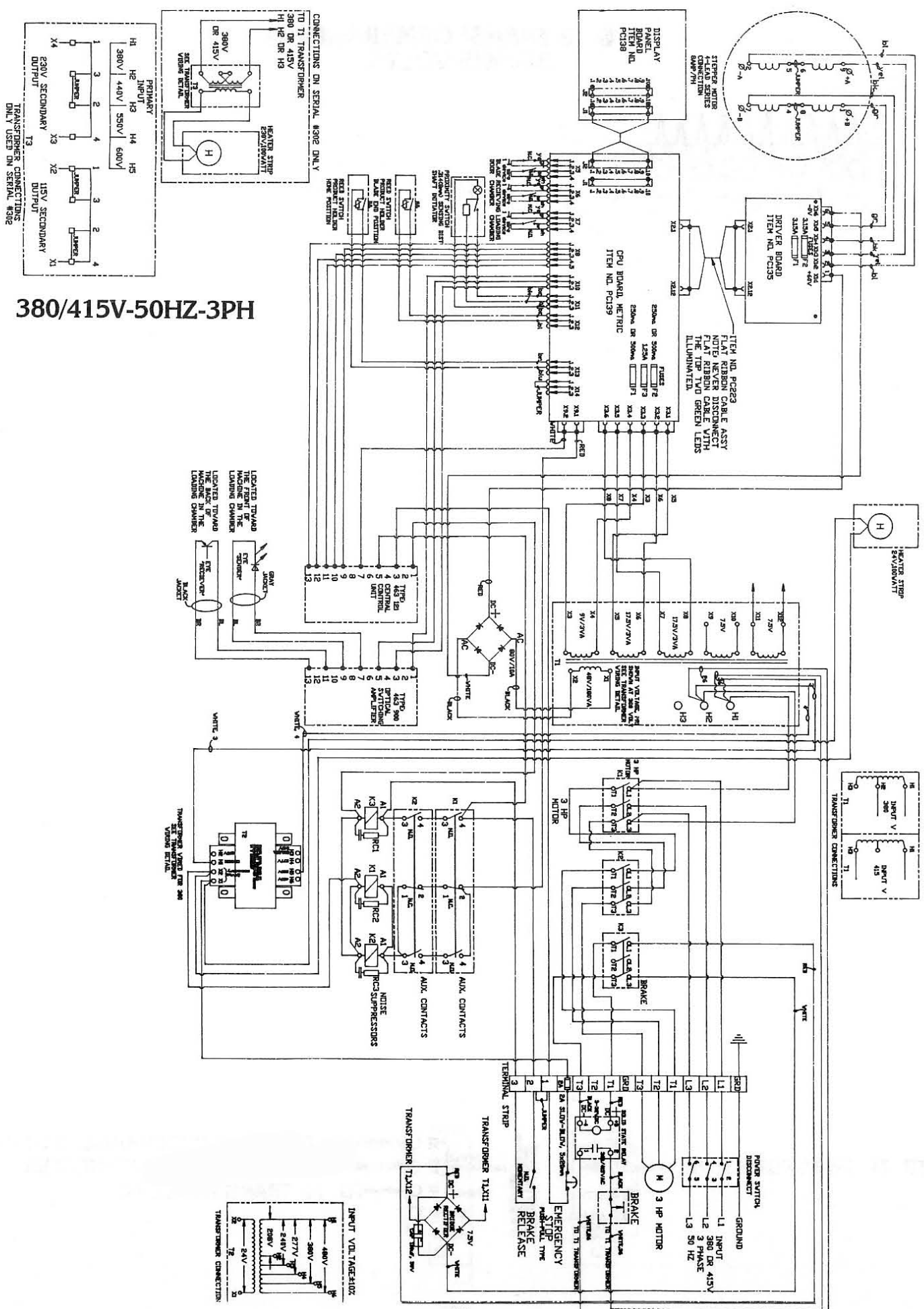

T1 & T2 TRANSFORMER WIRING 380/415 VOLTS

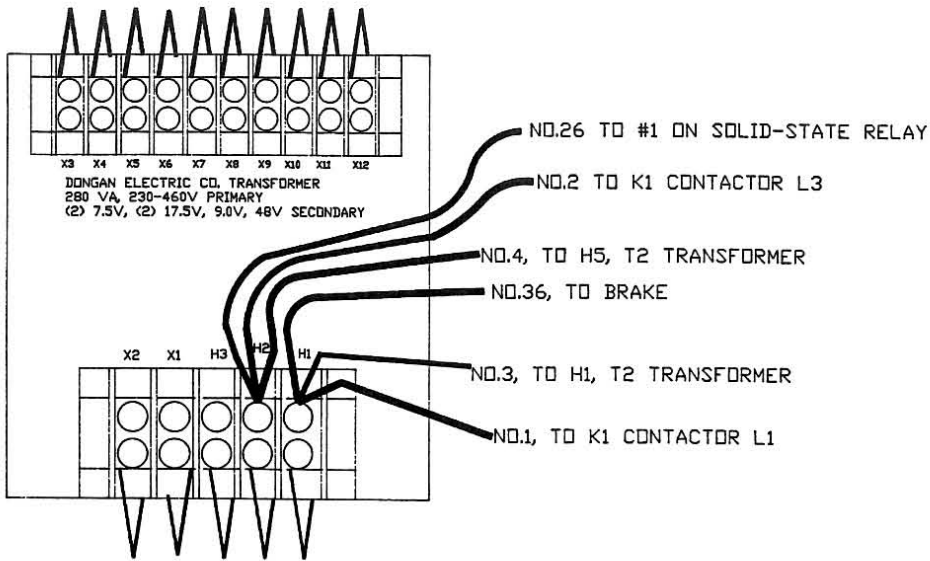

T1 TRANSFORMER
FOR A 380 VOLTAGE

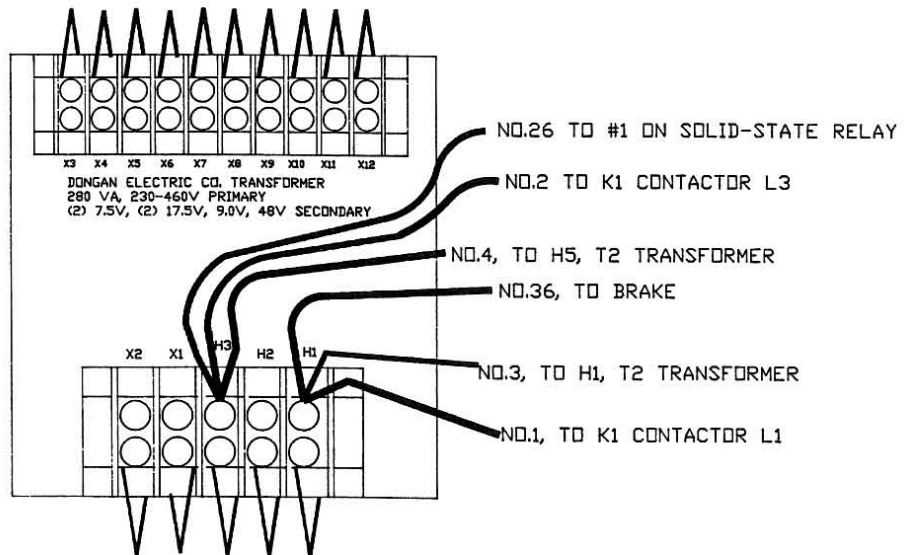

T1 TRANSFORMER
FOR A 415 VOLTAGE

T2 TRANSFORMER
FOR A 380/415 VOLTAGE

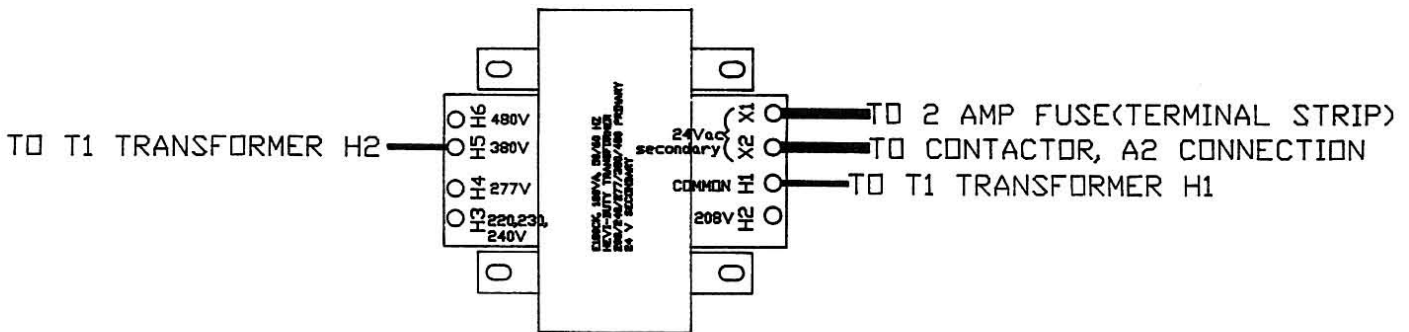

STEPPER MOTOR WIRING ALL VOLTAGES

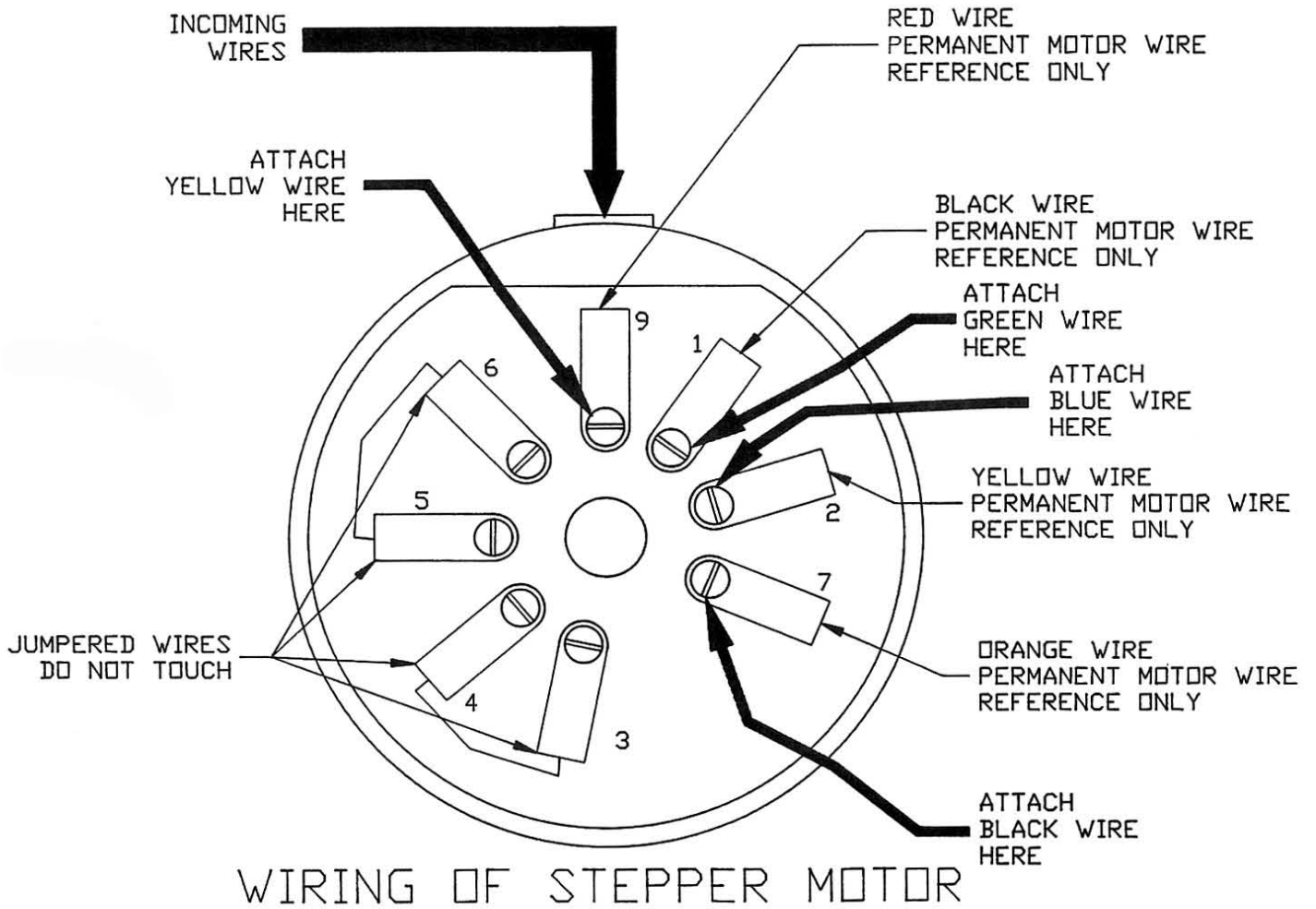

WIRING OF STEPPER MOTOR

MAINTENANCE



SHARP KNIFE BLADE TO AVOID SERIOUS PERSONAL INJURY

ALWAYS Turn Off, Unplug From Power Source and Perform Lockout/Tagout Procedure to This Machine **BEFORE** Servicing.

NEVER Touch This Machine Without Training and Authorization By Your Supervisor.

NEVER Bypass, Alter, or Modify This Equipment in Any Way From Its Original Condition.

PROMPTLY REPLACE Any Worn or Illegible Labels.

USE ONLY GENUINE BIRO Parts and Accessories Properly Installed.

A. TIMING ADJUSTMENT

Remove the rear panel. Look to the right for a proximity switch (Telemecanique brand), pointing at a locking collar attached to the main blade drive shaft. This proximity switch counts the number of revolutions and the starting and stopping position of the slicing blade. The proximity switch has a red LED on the back side of the switch to signal an "ON" situation. With the power "ON" the 109PC, open the blade door and push in the brake release button and hold the button in. At the same time rotate the slicing blade by hand clockwise through the loading chamber window. Look at the back side of the proximity switch LED and the position of the blade. When the LED comes "ON", stop rotating the blade. If the proximity switch is coming "ON" at a different location other than the illustration on the facing page, you will need to loosen the locking collar to attain the proper "ON" position. If the proximity switch is staying "ON" too long, loosen the proximity switch and back the proximity switch away from the locking collar. When the proximity is "OFF" the LED is off (not lit). See facing page for the proximity switch "OFF" position.

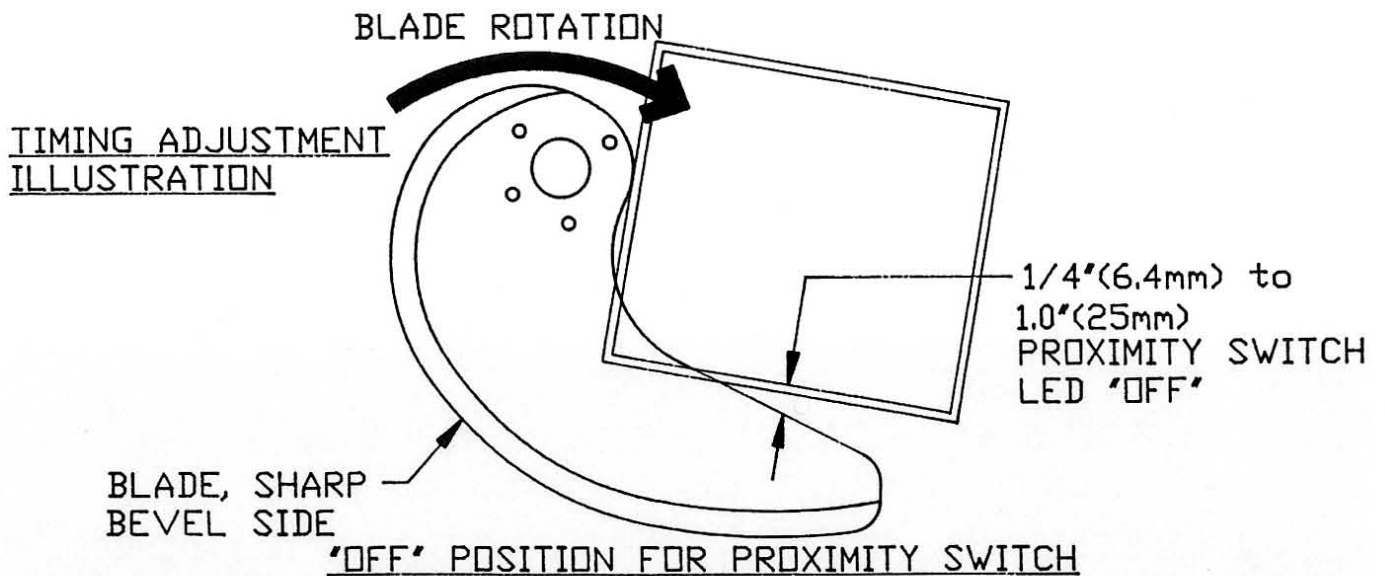
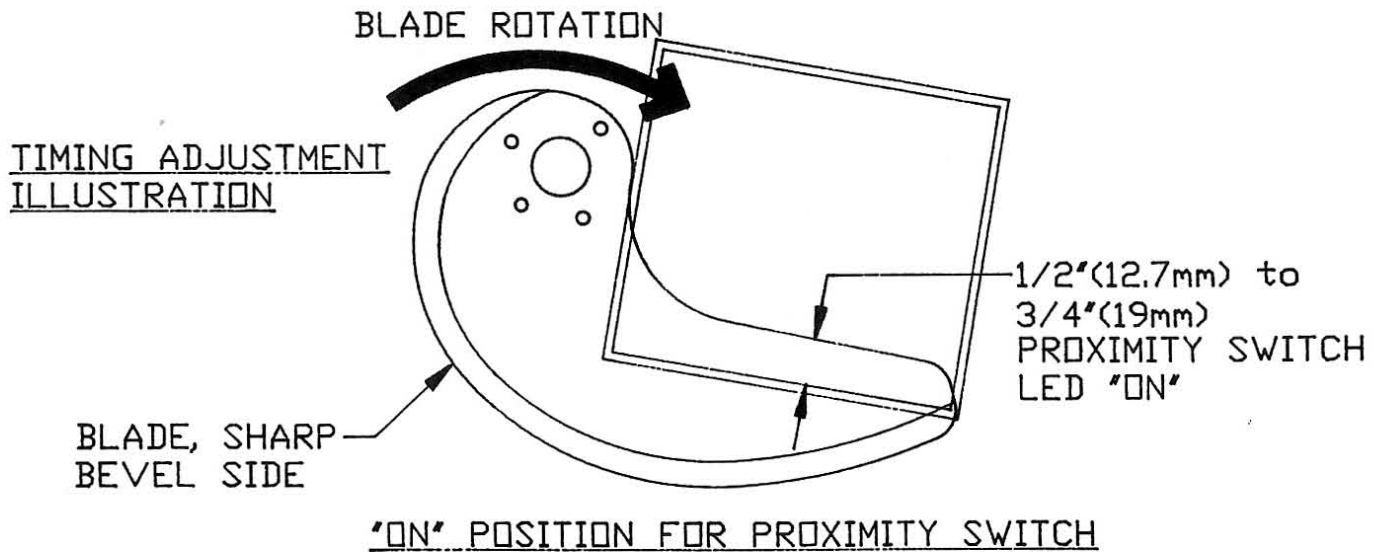
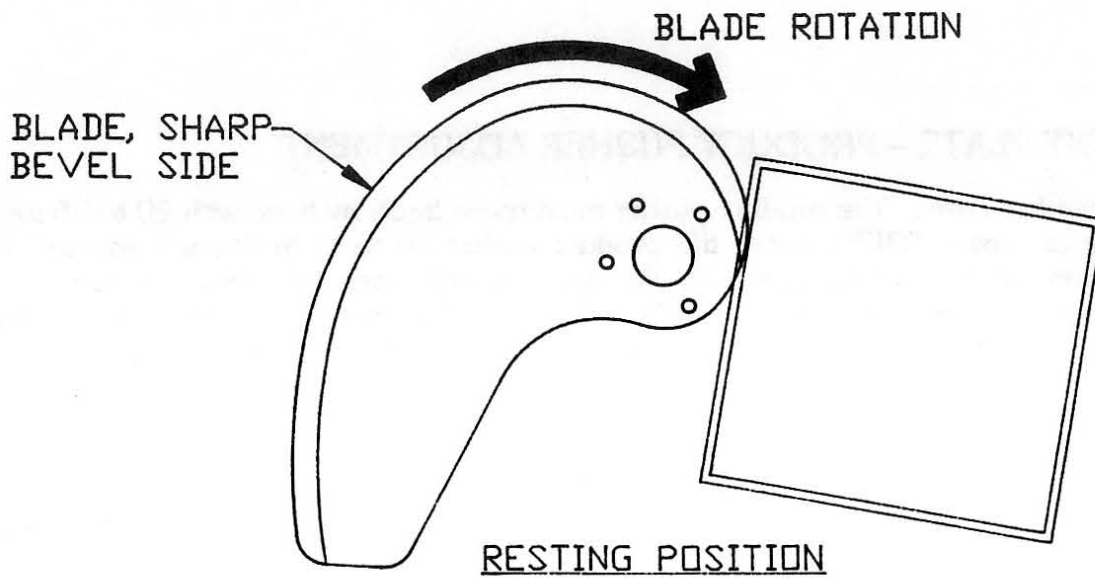

B. COMPONENT PLATE – PRODUCT PUSHER ADJUSTMENT

Lift the loading chamber cover. The product pusher must move freely by hand with 20 to 25 lbs. force. With electrical power "OFF", move the product pusher by hand to the left approx. 6" (153mm). Check the component plate, Item No. PC089. If you can rock the component plate left to right, the front v-rollers need to be adjusted. DO NOT over tighten the v-rollers to the square guide bar. The product pusher must move freely by hand with 20 to 25 lbs. force. See the assembly on the facing page. Remove the top panel with the loading chamber cover. Lift the top panel and set back enough to access the v-rollers and the product pusher component plate assembly. The front two v-rollers on the component plate are adjustable. The v-rollers are mounted on camshafts. Remove the hex head screws mounted on the sides of the component plate Item No. PC089. **Loosen the set screws located in the same holes as the hex (HHS020S) head screws.** One set screw per side. Next loosen the hex head screw HHS058S, and then hold for adjustment and **turn Item No. PC217** with a thin open box end wrench at the same time. This will adjust the v-roller in and out to the square guide bar. Retighten HHS058S and check the component plate for play. If the product pusher component plate assembly is snug and you can move the product pusher by hand, the adjustment is completed, be sure to tighten the two set screws, Item No. SSS13 in the sides of the component plate, Item No. PC089 and assemble the two hex head screws tight. Be sure the square guide bar is clean and re-grease with a light food grade grease or silicone spray. Move the product pusher assembly by hand and completely to the left and to the right to check the adjustment.

NOTE A: To remove the hex head screws HHS020S mounted on the side of the component plate, use a $\frac{7}{16}$ " box wrench or $\frac{7}{16}$ " socket and ratchet.

NOTE B: To remove the set screws SSS13, use an $\frac{1}{8}$ " allen wrench.

C: LAST CUT DISTRIBUTION

Last cut distribution is for cuts greater than 1". Turn last cut distribution on before selecting the number for the thickness.

If problems are experienced with last cut distribution, measure the product pusher from the home position to the end of the loading chamber to the left. And measure the product pusher from the blade end position to the end of the load chamber to the left, $34\frac{3}{4}$ (34.75) and $\frac{15}{16}$ " (.937) respectively. Next check product pusher for movement, right to left rocking motion. Check voltage of unit and line to ground for each leg.

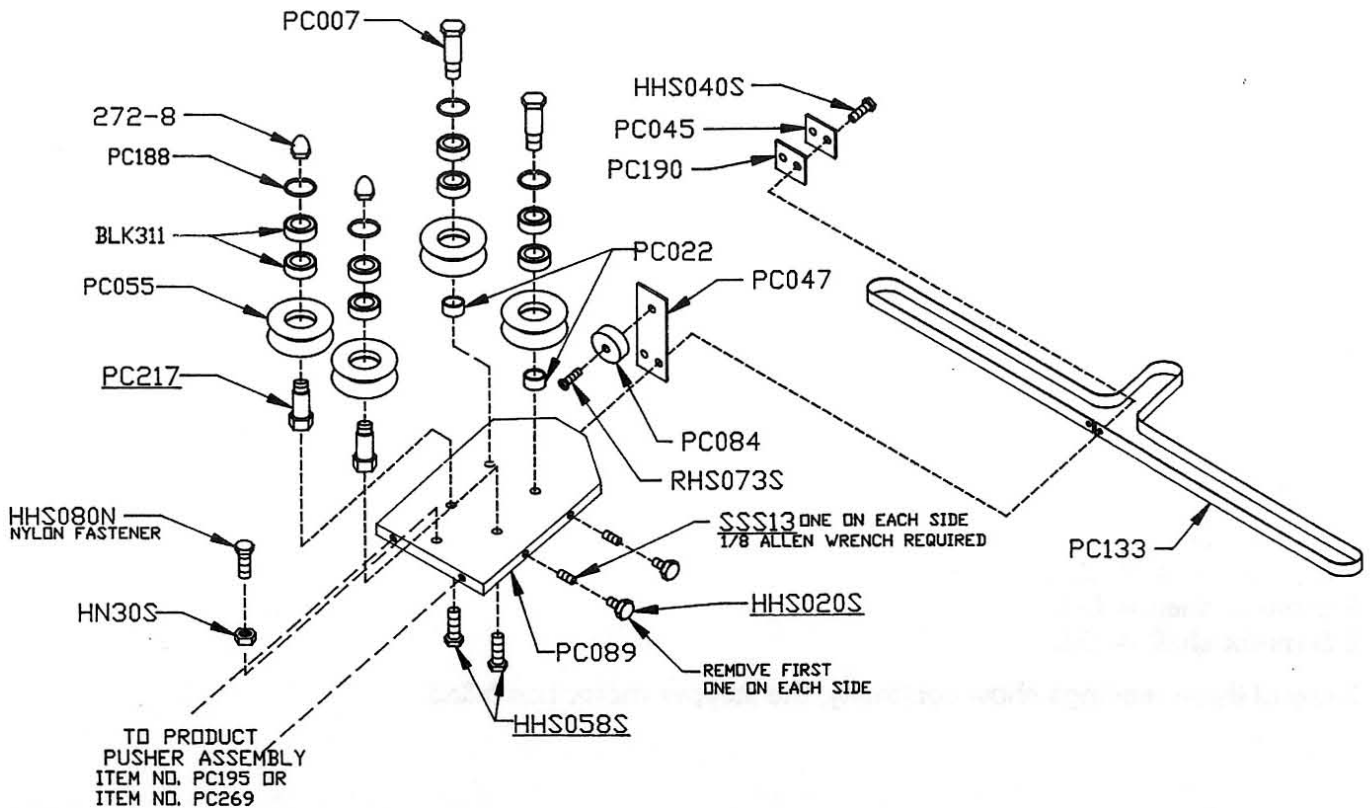
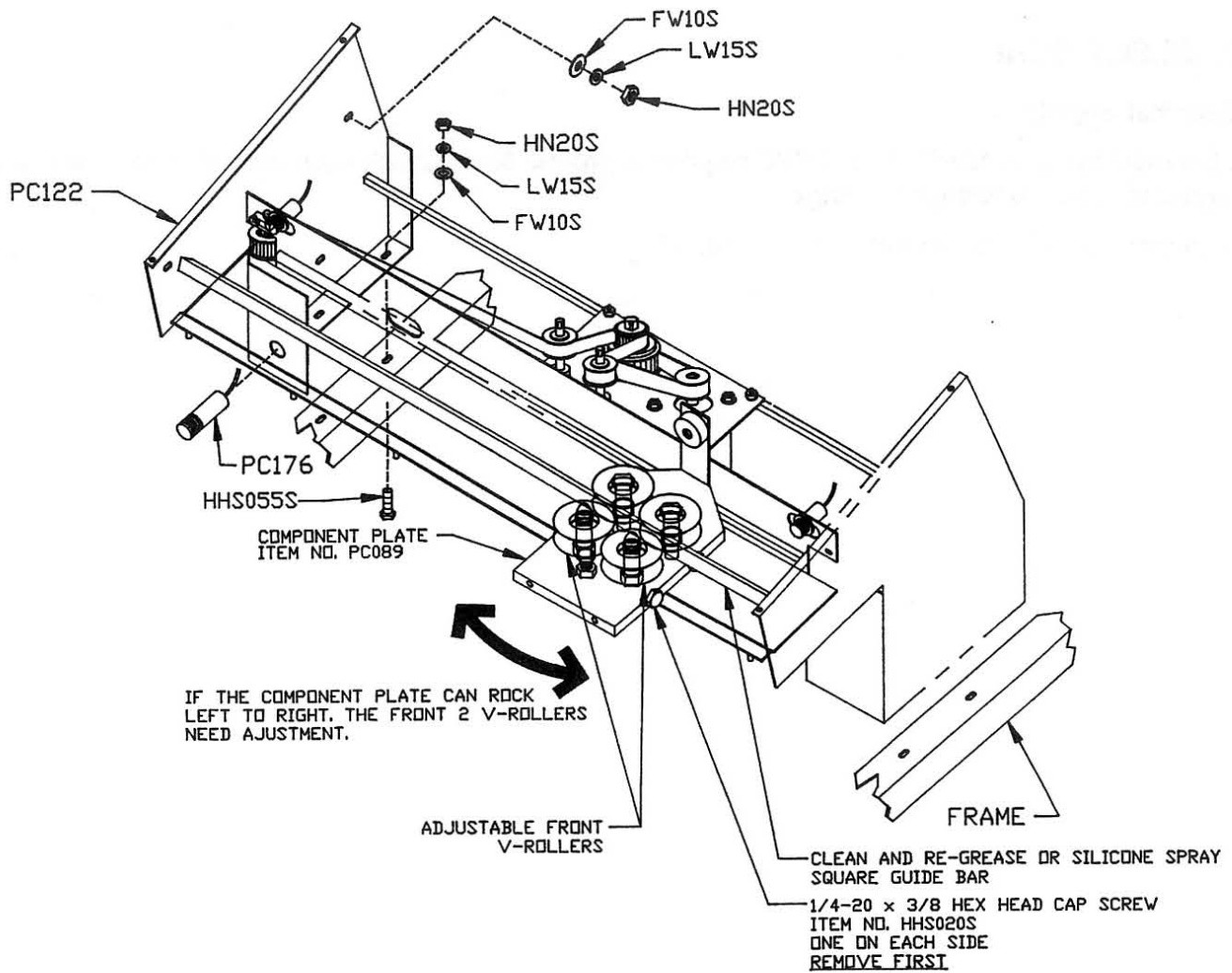

C. ELECTRICAL

Electrical Supply:

Is the machine grounded? The 109PC requires a ground line. Check each incoming electrical line to ground. Record voltage readings:

L1 to ground — L2 to ground — L3 to ground

Is one of the three electrical lines to ground higher or lower (voltage reading)? If it is, that electrical line must be attached to L2 in the electrical enclosure.

If any change is made to the electrical supply for the 109PC, check the rotation of the blade. The blade must rotate down through the product or clockwise looking at the blade from the receiving chamber. Check the blade rotation. A single blade rotation can be achieved by pressing the one stroke key. The direction of the blade can be changed by exchanging L1 and L3 electrical lines.

CPU Board LED's:

Green	Red	Red	Red	Green
D23	D22	D21	D20	D24

Main power on: D23, D20, D24 will light "ON" and the same will light in the reset mode or ready state.

Home Position:	D20, Red
Blade End Position:	D21, Red
Send, Receiver Eyes:	D23, Green
Proximity Switch, Blade Rotation and Position:	D22, Red
Power On:	D24, Green

Stepper Motor Test:

The stepper motor will accommodate pushing 50 lbs. of meat product and 30 lbs. of cheese product.

Disconnect the connections from the driver board assembly. Leave jumpers attached. Use a multi-meter and check continuity for OHM reading.

Check Across:

1 & 7 = .14 Ohm
9 & 2 = .14 Ohm
1 & 8 = .28 Ohm
4 & 7 = .28 Ohm
9 & 6 = .28 Ohm
5 & 2 = .28 Ohm

If readings are close, it is acceptable. If the readings are 1.0 or 2.0 the stepper motor has failed.

Check Across:

1 & motor shaft = O.L.
7 & motor shaft = O.L.
9 & motor shaft = O.L.
2 & motor shaft = O.L.

If any of these readings show continuity, the stepper motor has failed.

D. TROUBLE SHOOTING PC BOARDS

- A. 250ma fuses blow out on CPU board.
Reason: Flat ribbon cable was disconnected from the driver board assembly.
- B. There is no display LED's "ON" or number on display board.
Reason: The bottom 250ma fuse blew and/or the 1.25 A fuse blew.
- C. Default -1- will show on display, if cleared, the stepper motor will be erratic.
Reason: The top 250ma fuse blew on CPU board.
- D. No display, no LED's, no stepper motor, nothing works.
Reason: The 1.25A fuse blew on CPU board.
- E. No display, fuses still good, no burn marks on any PC boards.
Reason: Display cables disconnected.
- F. 250ma fuse blew, top fuse or bottom fuse.
Reason: Flat ribbon cable was not connected. The ribbon cable was only attached to the top set of pins.
- G. Not cutting, the display is "ON".
Reason: Flat ribbon cable was not connected. The ribbon cable was only attached to the bottom set of pins, or the 2A Slo-Blow fuse has blown.
- H. Cannot reset the display (from 8888's to 0.00).
Reason: The display connectors are switched or the 2A Slo-Blow fuse has blown, or the X9 connection to the CPU board is not connected, and/or X8 connection to the CPU is not connected.
- I. Stepper motor is making extreme noise or erratic motion.
Reason: Stepper motor has failed or driver board has failed. NOTE: Ask user about duration of noise or motion problem. If it has been some time running in this condition, the driver board assembly and the stepper motor will need replacing. Or check the flat ribbon cable. It may have fallen off the CPU board or driver board. NOTE: Check flat ribbon cable first. If the problem is not corrected, replace the stepper motor and the driver board assembly.
- J. Stepper motor is making extreme noise, but no movement. No fuses are blown. All connections are correct. If the noise has just occurred.
Reason: The CPU board has failed. Another check for this condition is to advance the stepper motor then press the stop button. The display may show: L.7.9 – This is a sign the CPU board has failed. Replacement is required.

RECOMMENDED SPARE PARTS LIST

QUANTITY	ITEM NO.	DESCRIPTION
2	BLK311	BEARING, 9MM
2	PC005	SLIDE WASHER, PRODUCT PUSHER
2	PC007	BEARING SHAFT, PRODUCT PUSHER
1	PC025	FASPIN, PRODUCT PUSHER
1	PC054	DRIVEN TIMING PULLEY, 5MM PITCH, 30 TOOTH
1	PC055	ROLLER, PRODUCT
1	PC124	BLADE, SMOOTH
1	PC125	BLADE, SERRATED
1	PC131	HTD BELT, 1000-8M-50
4	PC132	BELLEVILLE DISC SPRING
1	PC133	LINEAR TIMING BELT, 25T5
1	PC134	TIMING BELT, 25T5/480
1	PC144	CONTACTOR, 24 VOLT COIL
2	PC146	AUXILIARY CONTACT, N.O.
1	PC147	AUXILIARY CONTACT, N.C.
1	PC164	SENDER, EYE
1	PC165	RECEIVER, EYE
2	PC185	BEARING, 20MM
1	PC187	FLANGE BUSHING, DRIVEN TIMING PULLEY
2	PC188	RETAINING RING, ROLLER PRODUCT PUSHER
2	PC212	FUSE KIT, CONSISTS OF: 2 – 3.15A FAST-BLO, 5 × 20MM 2 – 250MA FAST-BLO, 5 × 20MM 1 – 1.25A FAST-BLO, 5 × 20MM 1 – 2.00A SLOW-BLO, 5 × 20MM