

WARNING-Read instruction before operating this equipment

Model:K5BW

Oxygen Concentrator User Manual

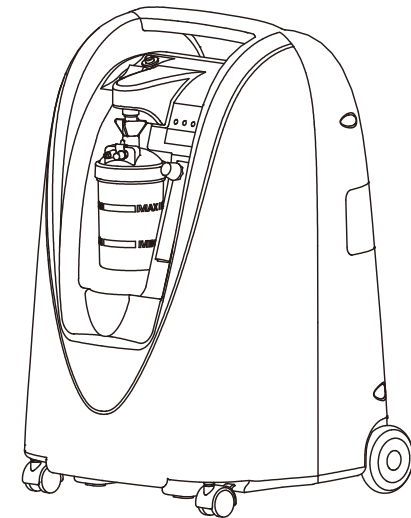

CONTENTS

CONTENTS

Introduction.....	3
Intended use of the device.....	3
Symbol Descriptions.....	3
Warnings	4
Contraindication.....	5
Adverse events/Hazards.....	5
Product Description.....	6
Operation.....	7
Specification.....	9
Oxygen concentration over altitude and flow rate.....	9
Transportation and Storage.....	10
Maintenance.....	10
Troubleshooting.....	12
EMC Information.....	13

Introduction

















The K5BW stationary oxygen concentrator is an externally powered, Class II, Type BF device. The essential function of the device is to provide oxygen at a volume that remains within tolerance-the tolerance was defined based on technical judgment from within the manufacturer's expertise in this specific medical application. In addition, the device's ability to detect certain error conditions such as low oxygen concentration and create an alarm is also considered a part of its essential function.

This user manual contains important information and safety precautions for the K5BW Oxygen Concentrator. Before using your oxygen concentrator, please read and understand this entire user manual. Save this user manual for future reference.

Intended use of this device

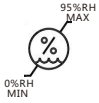
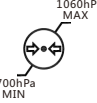
The K5BW Oxygen Concentrator is used on a prescriptive basis patients who are diagnosed as requiring supplemental oxygen. The oxygen concentrator will provide supplement, high oxygen concentration oxygen to these patients. It is not life-supporting or life-sustaining. It may be used continuously in a home or institutional/hospital setting.

SYMBOL DESCRIPTIONS

Symbol	Description	Symbol	Description	Symbol	Description
	Caution		No smoking		Fragile, Handle with care
	Keep Dry		This Side up		Batch code
	Class II equipment		Type BF applied part		Serial Number
	Date of Manufacture		Manufacturer		Temperature limit
	Humidity Limitation		Atmospheric pressure limitation		Refer to instruction manual/booklet
	CE marking		European Authorized Representative		Protected against solid foreign objects of 12.5mm diameter and greater

WARNING

- 1.The device to sale by or on the order of a physician.
- 2.It is responsibility of the patient and/or provider to make back-up arrangements for an alternative oxygen supply.
- 3.Availability of an alternate source of oxygen is required in case of power outage or mechanical failure.
- 4.The device should be located as to avoid pollutants or flames.
- 5.Portable and mobile RF communications equipment can affect medical devices.It is not recommended to operate the device near or adjacent to other equipment other than the K5BW oxygen concentrator.If adjacent use is necessary,the K5BW oxygen concentrator should be observed to verify normal operation in the configuration in which it will be used.
- 6.When storing or transporting the device,always keep it upright.
- 7.There is a risk of fire associated with oxygen enrichment during oxygen therapy. Do not use the oxygen concentrator or accessories near sparks or open flames.
- 8.To ensure receiving the therapeutic amount of oxygen delivery according to your medical condition Model K5BW must be used only after one or more settings have been individually determined or prescribed for you at your specific activity levels.
 - Be used with the specific combination of parts and accessories that are in line with the specification of the concentrator manufacturer and that were used while your settings were determined.
- 9.Use only water-based lotions or salves that are oxygen-compatible before and during oxygen therapy. Never use petroleum or oil-based lotions or salves to avoid the risk of fire and burns.
- 10.Do not lubricate fittings, connections,tubing, or other accessories of the oxygen concentrator to avoid the risk of fire and burns.
- 11.Use only spare parts recommended by the manufacturer to ensure proper function and to avoid the risk of fire and burns.

Use of this device at an altitude above 4000m or outside a temperature of 0 °C to 70 °C or a relative humidity above 95% RH expected to adversely affect the flow rate and the percentage of oxygen and consequently the quality of the therapy.
- 12.Oxygen makes it easier for a fire to start and spread. Do not leave the nasal cannula or mask on bed coverings or chair cushions, if the oxygen concentrator is turned on, but not in use; the oxygen will make the materials flammable. Turn the oxygen concentrator off when not in use to prevent oxygen enrichment.
- 13.If you feel discomfort or are experiencing a medical emergency while undergoing oxygen therapy, seek medical assistance immediately to avoid harm.
- 14.Geriatric, paediatrics or any other patient unable to communicate discomfort can require additional monitoring and or a distributed alarm system to convey the information about the discomfort and or the medical urgency to the responsible care giver to avoid harm.
- 15.Smoking during oxygen therapy is dangerous and is likely to result in facial burns or death. Do not allow smoking within the same room where the oxygen concentrator or any oxygen carrying accessories are located.



Foshan Keyhub Electronic Industries CO.,Ltd

Lane,East Second Street,Zhongyubei Road,Leliu,Shunde District,Foshan,
Guangdong,528322,P.R.China



European Representative

Lotus Global Co., Ltd

1 Four Seasons TerraceWest Drayton,MiddlesexLondon,UB7 9GGUnited Kingdom

Document Version: P010-C034 Rev 01 Software Version: P010-S002 V1.00

Recommended separation distances between portable and mobile RF communications equipment and the DEVICE .			
The K5BW is intended for use in an electromagnetic environment in which radiated RF disturbances are controlled. The customer or the user of the K5BW can help prevent electromagnetic interference by maintaining a minimum distance between portable and mobile RF communications equipment (transmitters) and the K5BW as recommended below, according to the maximum output power of the communications equipment.			
Rated maximum output power of transmitter (W)	Separation distance according to frequency of transmitter (m)		
	150 kHz~80 MHz $d = 1.2\sqrt{P}$	80 MHz~800 MHz $d = 1.2\sqrt{P}$	800 MHz~2.5 GHz $d = 2.3\sqrt{P}$
0.01	0.12	0.12	0.23
0.1	0.38	0.38	0.73
1	1.2	1.2	2.3
10	3.8	3.8	7.3
100	12	12	23
<p>For transmitters rated at a maximum output power not listed above, the recommended separation distance d in meters (m) can be estimated using the equation applicable to the frequency of the transmitter, where P is the maximum output power rating of the transmitter in watts (W) according to the transmitter manufacturer.</p> <p>NOTE 1 At 80 MHz and 800 MHz, the separation distance for the higher frequency range applies.</p> <p>NOTE 2 These guidelines may not apply in all situations. Electromagnetic propagation is affected by absorption and reflection from structures, objects and people.</p>			

16. Open flames during oxygen therapy are dangerous and is likely to result in fire or death. Do not allow open flames within 2 m of the oxygen concentrator or any oxygen carrying accessories.

17. Foshan Keyhub Electronic Industries Co., Ltd. assumes no liability for persons choosing not to adhere to manufacturer recommendations.

18. Patient shall consult with doctor before oxygen therapy. Prolonged exposure to high concentration oxygen will cause oxygen toxicity.

Contraindication

1. The device is not intended to be life-supporting nor life-sustaining.
2. In certain circumstances, oxygen therapy can be hazardous. Please seek medical advice before using this device.
3. The device is designed to provide a flow of high purity oxygen up to 5LPM continuous. The device should only be used by patients prescribed oxygen therapy within this range.
4. As the device will alarm through audio and visual indicators, patients who are unable to communicate discomfort, hear, see and or understand the alarms may require additional monitoring.

ADVERSE EVENTS/HAZARDS

Failure to adhere to the statements below may impair performance of the device and may void all warranties.

1. **DO NOT** use oil, grease or petroleum-based products on or near the device.
2. **DO NOT** use power suppliers or air filters other than those that came with the system.
3. **DO NOT** allow smoking or open flames within 3m of the device as the device produces enriched oxygen gas which accelerates combustion.
4. **DO NOT** obstruct the air flow to the inlet and exhaust vents on the oxygen concentrator. the device should be located in the ventilated area.
5. **DO NOT** submerge the device liquid. The device should not be exposed to water or precipitation as it may damage the electronic components of the device and will void all warranties.
6. **DO NOT** operate or expose the device to temperatures and humidity levels outside the specified operational environment conditions outlined in the specifications section. Excessive temperatures and humidity levels may damage the device.
7. **DO NOT** plug the device into the same electrical outlet as major appliances. Doing so may cause an electrical overload.
8. Use of certain humidifiers not specified for use with oxygen concentrator may impair performance

PRODUCT DESCRIPTION

Front view (Figure1)

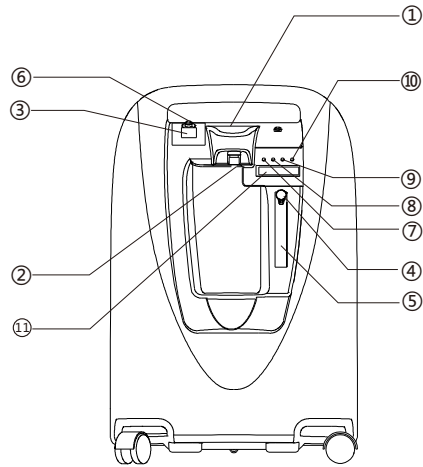

Figure1

1. Operating instruction
2. Outlet connector
3. Switch
4. Flow regulating button
5. Flow meter
6. Circuit breaker
7. Indicating light for POWER
8. Indicating light for "NORMAL O2 PURITY"
9. Indicating light for "LOW O2 PURITY"
(For purity-monitoring type only)
10. Indicating light for Maintenance Alarm
11. LCD screen

Back view (Figure2)

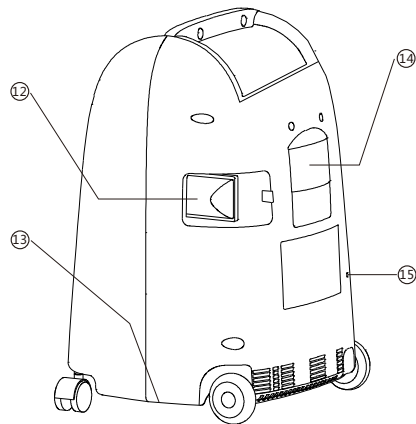

Figure2

12. Maintenance entrance -
with Intake filter inside
13. Exhaust
14. Air filter
15. Power cord

Accessories:

Humidifier Bottle	P004-C005	1 set
Nasal Cannula	P021-C028	1set
Oxygen Connector	P004-C025	1set

Guidance and manufacture' s declaration – electromagnetic immunity

The K5BW is intended for use in the electromagnetic environment specified below. The customer or the user of the K5BW should assure that it is used in such an environment.

Immunity test	IEC 60601 test level	Compliance level	Electromagnetic environment - guidance
Conducted RF IEC 61000-4-6	3 Vrms 150 kHz to 80 MHz	N/A	Portable and mobile RF communications equipment should be used no closer to any part of the K5BW, including cables, than the recommended separation distance calculated from the equation applicable to the frequency of the transmitter.
Radiated RF IEC 61000-4-3	3 V/m 80 MHz to 2.5 GHz	3 V/m	Recommended $d = 1.2\sqrt{P}$ $d = 1.2\sqrt{P}$ 80 MHz ~ 800 MHz $d = 2.3\sqrt{P}$ 80 MHz ~ 800 MHz separation distance Where P is the maximum output power rating of the transmitter in watts (W) according to the transmitter manufacturer and d is the recommended separation distance in metres (m). Field strengths from fixed RF transmitters, as determined by an electromagnetic site survey, a should be less than the compliance level in each frequency range.b Interference may occur in the vicinity of equipment marked with the following symbol: 

NOTE 1 At 80 MHz and 800 MHz, the higher frequency range applies.

NOTE 2 These guidelines may not apply in all situations. Electromagnetic propagation is affected by absorption and reflection from structures, objects and people.

^a Field strengths from fixed transmitters, such as base stations for radio (cellular/cordless) telephones and land mobile radios, amateur radio, AM and FM radio broadcast and TV broadcast cannot be predicted theoretically with accuracy. To assess the electromagnetic environment due to fixed RF transmitters, an electromagnetic site survey should be considered. If the measured field strength in the location in which the DEVICE is used exceeds the applicable RF compliance level above, the DEVICE should be observed to verify normal operation. If abnormal performance is observed, additional measures may be necessary, such as reorienting or relocating the K5BW.

^b Over the frequency range 150 kHz to 80 MHz, field strengths should be less than 3 V/m.

Guidance and manufacture's declaration – electromagnetic immunity			
The K5BW is intended for use in the electromagnetic environment specified below. The customer or the user of K5BW should assure that it is used in such an environment.			
Immunity test	IEC 60601 test level	Compliance level	Electromagnetic environment - guidance
Electrostatic discharge (ESD) IEC 61000-4-2	±6 kV contact ±8 kV air	±6 kV contact ±8 kV air	Floors should be wood, concrete or ceramic tile. If floor are covered with synthetic material, the relative humidity should be at least 30%.
Electrical fast transient/burst IEC 61000-4-4	±2 kV for power supply lines ±1 kV for input/output lines	±2kV for power supply lines	Mains power quality should be that of a typical commercial or hospital environment.
Surge IEC 61000-4-5	± 1 kV line(s) to line(s) ± 2 kV line(s) to earth	±1 kV differential mode	Mains power quality should be that of a typical commercial or hospital environment.
Voltage dips, short interruptions and voltage variations on power supply input lines IEC 61000-4-11	<5% UT (>95% dip in UT) for 0.5 cycle 40% UT (60% dip in UT) for 5 cycles 70% UT (30% dip in UT) for 25 cycles <5% UT (>95% dip in UT) for 5 sec	<5% UT (>95% dip in UT) for 0.5 cycle 40% UT (60% dip in UT) for 5 cycles 70% UT (30% dip in UT) for 25 cycles <5% UT (>95% dip in UT) for 5 sec	Mains power quality should be that of a typical commercial or hospital environment. If the user of the K5BW requires continued operation during power mains interruptions, it is recommended that the K5BW be powered from an uninterruptible power supply or a battery.
Power frequency (50Hz/60Hz) magnetic field IEC 61000-4-8	3 A/m	3 A/m	Power frequency magnetic fields should be at levels characteristic of a typical location in a typical commercial or hospital environment.
NOTE U _T is the a.c. mains voltage prior to application of the test level.			

OPERATION

WARNING: Read the safety section and operating instructions in this manual before use.

PREPARATION

Attach appropriate accessories to the oxygen outlet.

Tubing Connection: (Figure 3)

1. Thread the oxygen output connector onto the outlet.
2. Directly attach the Nasal Cannula to the connector. Figure 3
Tubing Connection with Humidifier bottle:(Figure 4)

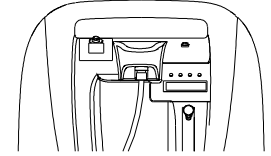

Figure3

WARNING: The use of a humidifier bottle with a concentrator must be prescribed by a physician. If you are prescribed to use a humidifier bottle as part of your therapy, please follow these steps:

1. Fill the humidifier bottle with distilled water up to the top mark.

WARNING: DO NOT overfill the humidifier bottle.

2. Thread the wing nut on the top of the bottle to the oxygen outlet so that the bottle is suspended. Make sure it is firmly tightened.

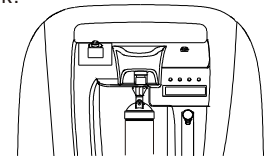

Figure4

3. Attach the oxygen tubing to the outlet of the bottle. Figure 4

NOTE: The material of oxygen outlet is metal which can reduce the propagation of fire for the safety of the patient.

WARNING: DO NOT reverse the oxygen inlet and output connections, or water from the humidifier bottle will travel through the oxygen hose back to the patient. Cannula, mask or other accessories prescribed by your physician should be attached with the oxygen tubing.

. SETUP

1. Ensure that the concentrator power switch is in the "OFF" position. Plug the AC connector into the power outlet.
2. Press the power switch to "ON" position. The oxygen concentrator starts running. It will takes approximately 3 minutes to reach full oxygen concentration.
3. Turn the flow-meter knob to center the flow-meter ball on the LPM prescribed. The flow-meter can be adjusted only after the unit is powered on.
4. Now your oxygen concentrator is running. Please choose the using time as prescribed.

WARNING

1. Improper use to the power cord and plug can cause burning, fire or other electric shock hazards.
2. Oxygen is flammable. No smoking near the working oxygen concentrator.

Purity Indicator:

If the purity of the oxygen concentrator is below 82%, the yellow light on the panel will be on.

Alarm indicator

When the power of the oxygen concentrator loses suddenly, the concentrator will beep for 1 second to alert the patient.

Circuit breaker (Reset button)

Your oxygen concentrator is equipped with a circuit breaker (reset button) to protect the electrical circuits from overload, next to the power switch. In the event of an overload, the circuit breaker button will pop out. To reset the circuit breaker, please push down the button.

SHUTDOWN

After using the concentrator for the time prescribed by your physician, move the concentrator's power switch to the "OFF" position to turn off concentrator power. Unplug the AC connector from the power outlet.

Transport the oxygen concentrator

The K5BW Oxygen Concentrator is equipped with casters for transportation. To transport the concentrator, please do these first:

1. Remove and store any accessories, such as tubing, cannulas, masks, and humidifier bottle, if equipped.
2. Fold and wrap the power cord and attach it to the concentrator cabinet using the strap.

1) This product needs special precautions regarding EMC and needs to be installed and put into service according to the EMC information provided, and this unit can be affected by portable and mobile RF communications equipment.

2)* Do not use a mobile phone or other devices that emit electromagnetic fields, near the unit. This may result in incorrect operation of the unit.

3) Caution: This unit has been thoroughly tested and inspected to assure proper performance and operation!

4)* Caution: this machine should not be used adjacent to or stacked with other equipment and that if adjacent or stacked use is necessary, this machine should be observed to verify normal operation in the configuration in which it will be used.

EMC Information

Guidance and manufacturer's declaration – electromagnetic emission		
The K5BW is intended for use in the electromagnetic environment specified below. The customer of the user of the K5BW should assure that it is used in such an environment.		
Emission test	Compliance	Electromagnetic environment – guidance
RF emissions CISPR 11	Group 1	The K5BW uses RF energy only for its internal function. Therefore, its RF emissions are very low and are not likely to cause any interference in nearby electronic equipment.
RF emission CISPR 11	Class B	The K5BW is suitable for use in all establishments, including domestic establishments and those directly connected to the public low-voltage power supply network that supplies buildings used for domestic purposes.
Harmonic emissions IEC 61000-3-2	Not Applicable	
Voltage fluctuations/ flicker emissions IEC 61000-3-3	Not Applicable	

Preventive Maintenance Checklist

Model No: _____ Serial No: _____

ON EACH INSPECTION					
Record Elapsed Hours on Hour Meter					
Clean the Filter(s) (Refer to Cleaning the Filter.)					
Check Prescribed L/min. Flow-rate					
DURING PREVENTIVE MAINTENANCE SCHEDULE, OR BETWEEN PATIENTS					
12000 hours of continuous use					
12000 hours of continuous use					
Check Oxygen Concentration					
Clean/Replace Filter(s) (Refer to Cleaning the Filter.)					
Check Power Loss Alarm					
To be conducted by supplier or qualified service technician. Refer to service manual.					

TROUBLESHOOTING

The following troubleshooting chart can help you analyze and correct oxygen concentrator malfunctions. If below suggested procedures do not work, please switch to an alternate reserve oxygen source and contact your distributor.

WARNING: DO NOT REMOVE THE CABINET UNLESS YOU ARE A QUALIFIED TECHNICIAN CHART OF TROUBLESHOOTING

Symptom	Possible Causes	Remedy
Concentrator power switch is on, but concentrator will not turn on	No power to the device	1)Ensure that power cord is connected to the wall outlet. 2)Ensure that there is power in the wall outlet. 3)Ensure that an extension cord is not used. 4)Ensure that circuit breaker (reset button) is not popped out; if so, push it down. 5)If condition persists, contact the authorized distributor for repair.
Concentrator works, but little or no oxygen from outlet.	Possible blockage	1)Inspect tubes and cannula to ensure that they are not kinked or blocked. Smooth tubes to unblock. 2)Check the humidifier bottle, if equipped, for leaks or jamming. Remove humidifier bottle, reinstall, and tighten. 3) If condition persists, contact the authorized distributor for repair.
The flow meter ball located on "0" position, or the flow is unstable.	Possible flow meter problem	Adjust flow meter knob. If condition persists, contact the authorized distributor for repair.

SPECIFICATION

Specification	K5BW
Device Electrical Classification	Class II ,Type BF
Weight	18.5KG
Dimensions	305x300x535(L*W*H)mm
Mode of Operation	Continuous
Flow setting control	0 to 5 LPM
Oxygen concentration	93%±3% (0-5LPM)
Oxygen concentration sensor alarm	82% or less
Maximum outlet pressure	8.5psi
Average sound level	50.4dB(A)
Power supply	230VAC~50Hz

Oxygen Concentration under the operational Temperature/Humidify range and flow rate

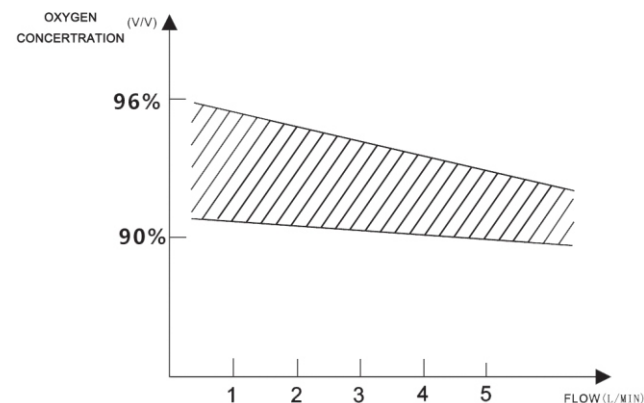

Device operation above or outside of the voltage, LPM, temperature, humidify and/or altitude values specified may decrease oxygen concentration levels.

Oxygen concentration over altitude and flow rate
Oxygen concentration over altitude range 0-4000m

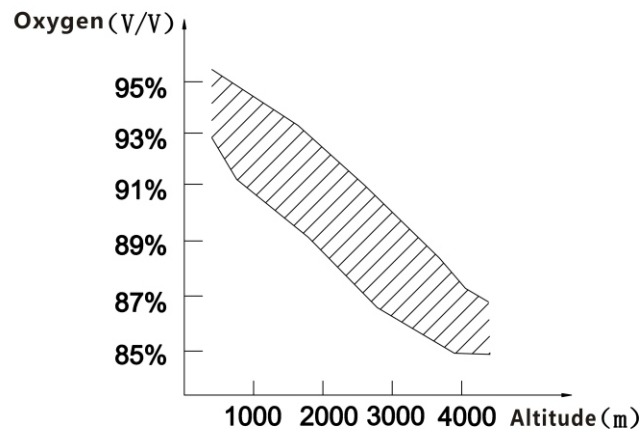

Environmental conditions for Use, Storage and Transport

Operational Temperature range: 10 °C to 35 °C

Operational Humidify Range: 0% to 95% RH

Storage Temperature Range: 0 °C to 60 °C

Storage Humidify Range: 0% to 95% RH

At atmospheric pressure range: 700 to 1060 hPa

*The variation of the flow does not exceed the greater 10% of the set value or 2 LPM when a back pressure of 7kPa(1 psi) is applied to the device output.

*Degradation may occur for settings less than 1LPM.

MAINTENANCE

All maintenance except cleaning the cabinet, and cleaning the humidifier bottle, described in the following section, is to be performed only by authorized service personnel.

DANGER: The concentrator was specifically designed to minimize routine preventive maintenance.

Preventive maintenance or adjustments to the concentrator are to be performed only by authorized service personnel; the performance of such maintenance or adjustment by any other personnel could void the warranty and create a hazardous condition, which could result in death or serious personal injury.

WARNING: Ensure that the concentrator is unplugged from the AC power source and the power switch is at the "OFF" position before performing maintenance on the concentrator.

Cleaning the cabinet

Clean the cabinet monthly, or more often if it gets dirty or your environment is very dirty.

1. Ensure that the power cord is unplugged and the power switch is at the "OFF" position.
2. Clean the cabinet with a mild household cleanser and a clean, non-abrasive cloth or sponge.

WARNING: DO NOT immerse the concentrator in water or other liquid.

DO NOT pour liquids on the concentrator while cleaning.

DO NOT allow any liquid to enter the concentrator.

CAUTION: Many cleansers must be diluted before use. Follow the manufacturer's directions carefully to avoid damaging the cabinet.

Cleaning the humidifier bottle

Change the water in the humidifier bottle every day.

Wash the humidifier bottle weekly with warm soapy water, and rinse thoroughly with hot water before refilling.

Replacement Parts

Below replacement parts and accessories are available through your distributor.

Cannula, Mask and Tubing

Clean and replace the cannula, mask and tubing as distributor's instruction.

Intake Filter

It is recommended that the Air Filter be changed every six months. If the K3BW oxygen concentrator is used in a dusty environment, filter replacement may be required more frequently. Contact your equipment provider for additional replacement filters.

Installing a new air filter:

1. Remove the Air Filter Access Door.
2. Remove the old Air Filter.
3. Pull the Air Filter out of its housing.
4. Replace the Air Filter.
5. Put the new Air Filter into its housing.
6. Firmly push down on the Air Filter until it is securely in place.

Expected service life of parts and accessories

Humidifier Bottle	1 years or 100 times
Nasal Cannula	single use only