

SED-2000 USERS MANUAL

READ AND SAVE THESE INSTRUCTIONS

It is highly recommended that a licensed electrician or licensed contractor install these units.

WARNINGS

- Always unplug or disconnect air cleaner from the power supply before servicing.
- To reduce the risk of shock or injury to persons, do not expose to water or rain, do not use in a window.
- Do not use this fan with any solid-state speed control device.

EQUIPMENT

The SED-2000 is equipped with 4 eye bolts, 16" on center.

Each unit includes a 1 year supply of filters which consists of;

- Twelve (12) - 1/2" Pre-filters
- Six (6) - 1/2" Carbon filters
- One (1) - 12" 95% HEPA Filter

Electrical: 120 volts and field hard wired.

INSTALLATION

Step 1. Remove the system from the shipping container. Open side access door and remove all 3 filters from the unit. This will make the unit lighter for installation.

Step 2. After deciding on an installation location, locate the studs, rafters, or joists which the unit will be attached to, install eye lags 16" on center (field provided). (Screws if wall mounted are field supplied). We suggest the use of 1 ½" to 2" Philips pan head screws and fender washers.



Pure n Natural Systems, Inc.
www.purenatural.com
1-800-237-9199
email – helpdesk@purenatural.com

Step 3. Use industrial hanging chain (field provided) attach to one eye bolt. Make sure chain is tight. Next connect chain to eye lags on rafter or joists. Continue this procedure for the remaining three eye bolts and lags.

Step 4. Attach duct work to system, connect power to 120-volt power supply. Reinstall filters close door and latch.

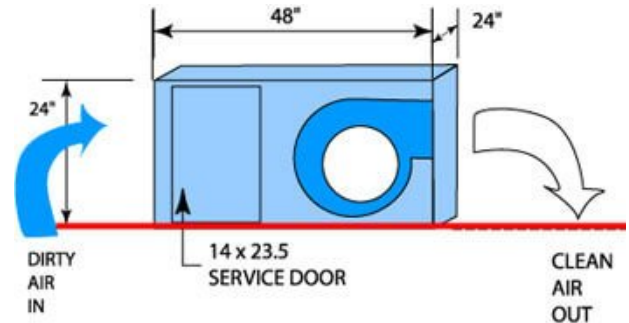

FILTER MAINTENANCE

The SED-2000 is a 3 Filter System

- Pre-Filter Replace every 3 to 4 weeks
- Charcoal Filter Replace at least every 3-4 months.
- HEPA Filter Replace at least every 12 months.

CHANGING FILTERS

Step 1. Unlatch side door.

Step 2. The blue **pre-filter** is the first filter located in the unit and is changed every 3 to 4 weeks.

Step 3. The **carbon filter** is located behind the pre-filter and is changed every 4 months.

Step 4. To change the **H.E.P.A. filter** remove the pre-filter and carbon filter from unit and slide out the H.E.P.A. filter, dispose and replace with new filter. The H.E.P.A. Filter is changed once a year.

All Filters are disposable and cannot be cleaned or washed. NO CLEANING REQUIRED. Filter maintenance varies according to individual environments.



Pure n Natural Systems, Inc.
www.purenatural.com
1-800-237-9199
email – helpdesk@purenatural.com

SED-2000 Ducted HEPA Air Cleaner

Designed for unobtrusive, ducted installation, the SED series serves an entire home or office's air filtration requirements with a single unit. The SED Air Cleaner is suitable for homes, offices or commercial establishments and can be used with hydronic or radiant heating and/or cooling systems. Inflow and outflow air circulation can be customized to your specifications. Consult your HVAC contractor for installation and required ducting (not included). Its efficient multistage HEPA/Carbon filtering assures quality indoor air year round. All 3 filters on the SED2000 air cleaner are easily accessible. 1 unit recommended for every 2,000 square feet.



SPECIFICATIONS

Capacity	Up to 2,000 Sq. Ft.
2 Speed	High – 1650 CFM Low – 1450 CFM
Installation Options	Joist or Wall Mount
Dimensions	48" L x 24" W x 24" H
Cabinet Construction	16-gauge gray steel cabinet
Shipping Weight	160 lbs.
Electrical	9 amps 120V*, 1/2 Hp
Warranty	10-year warranty. Warranty is effective as long as filters are changed as required.
Certifications	All electrical components and fan motor are UL listed & CSA certified

NOTE: The SED-2000 is equipped with 4 eye bolts installed 16" on center on top of each unit for easy installation.

NOTE: The SED series is designed for whole-house contractor-installed ducted use. Mounting is joist or wall (specify at time of order). For optimal air quality it is recommended that a supply air diffuser be located in every room of the home. At minimum there should be at least one supply and one return per floor. Contact a local HVAC Contractor for installation and required ducting (not included).

* The SED-2000 Whole house air purification system is designed to be wired to a 120 VAC power source that is interlocked with the HVAC system blower. Wiring connections are located in the junction box. All wiring shall meet local codes.

* Lifetime Blower/Motor warranty applies if filters are changed as required and are purchased from Pure n Natural Systems, Inc.



Pure n Natural Systems, Inc.
www.purennatural.com
1-800-237-9199
email – helpdesk@purennatural.com