

## LED Round High Bay SATELLITE PRO



### The Any-Application High Bay

Satellite Pro High Bay fixture offers the latest in performance, functionality and versatility for general lighting in warehouses and gymnasiums to food production areas. With its smooth aluminum die-cast housing, IK08 impact resistant lens, NSF certification and IP69K dust, steam and high-water pressure rating, the Satellite Pro meets all requirements for food processing facilities. Models are available in 120-277V and 277-480V high voltage configurations in 150 or 240 watts. Accessories include a pre-programmed plug and play motion sensor, optional remote control capable of unlocking further motion sensor functionality and an emergency battery backup kit.



### FEATURES

- Aluminum die-cast housing with white powder coat finish
- IK08 impact rated polycarbonate lens
- IP69K rated for maximum resistance to dust, steam, and high-pressure water
- NSF certified for food processing hose down requirements
- Ring hook and J-hook included to be used with the M10 threaded hub for various mounting options
- Assembled with 5' safety cable, 6' power cord, and 6' dimming cord
- Optional accessories include microwave motion sensor, remote control, NPT adapter kit, and emergency battery backup

### SUGGESTED APPLICATIONS

- Food production areas
- Warehouses
- Gymnasiums
- Manufacturing facilities
- Retail stores

## LED Round High Bay SATELLITE PRO

### GENERAL SPECIFICATIONS

**Frequency:** 50/60Hz  
**Power Factor, THD % :** >0.9, < 10%  
**Dimmable:** 0-10V<sup>1</sup>  
**Efficacy:** 138 LPW  
**CCT:** 5000K  
**Minimum CRI:** 85  
**IES Distribution:** Type V  
**Functional Life (L70):** 50,000 hours  
**Location Rating:** Wet  
**IP Rating:** IP69K Rated  
**Ambient Operating Temperature:** -30°F to 122°F

### TYPICAL MOUNTING HEIGHTS

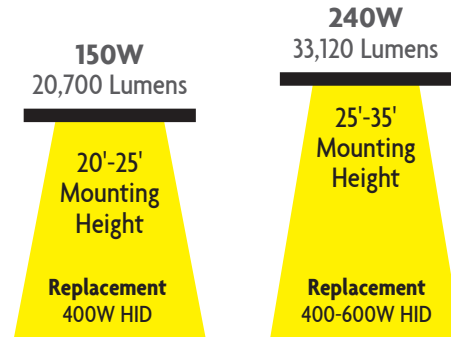

### ITEM SPECIFICATIONS / ORDER INFO

Catalog Number	Order Code	UPC	Lumens	Wattage	Input Voltage	Input Current @120V/277V	DLC ID*
F-LUHB/150/5K/G3	72713	751338038431	20,700	150W	120-277V	1.80/0.85A	PL09AENO60CM
F-LUHB/240/5K/G3	72718	751338038448	33,120	240W	120-277V	2.70/1.40A	PLPB9XAO5PRP
F-LUHB/150/5K/HV/G3	72717	751338038462	20,700	150W	277-480V	0.85/0.45A	PLIEZ4KZTVF1
F-LUHB/240/5K/HV/G3	72715	751338038486	33,120	240W	277-480V	1.40/0.70A	PLSPIVJII29R

### NOMENCLATURE

**F-LUHB** = Fixture - LED High Bay / **150W** = 150 Watt / **5K** = 5000K / **HV** = High Voltage 277-480V / **G3** = Generation  
 / **240W** = 240 Watt / **Blank** = 120-277V

### ENERGY SAVINGS

Catalog Number	LED Wattage	HID Replacement Wattage	Watts Saved	Yearly Savings	5 Year Savings
<b>Based on 12 hours/day and \$0.11/kWh</b>					
F-LUHB/150/5K/xx/G3	150W	400W	250W	\$120	\$602
F-LUHB/240/5K/xx/G3	240W	400-600W	360W	\$173	\$867

### DIMENSIONS / WEIGHTS

Catalog Number	(A)	(B)	Weight
F-LUHB/150/5K/G3	13.62"	8.82"	7.3 Lbs.
F-LUHB/240/5K/G3	16.46"	8.82"	11.0 Lbs.
F-LUHB/150/5K/HV/G3	13.62"	8.82"	8.3 Lbs.
F-LUHB/240/5K/HV/G3	16.46"	8.82"	12.6 Lbs.

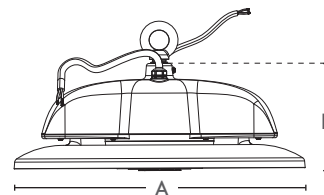

### MOUNTING ACCESSORIES (Sold Separately)

Catalog Number	Order Code	UPC	Description
F-LUHB/M10-NPTKIT/G3	72727	751338038516	NPT Adapter Kit M10 to 3/4", M10 to 1/2"



### NOTES:

\*DLC Primary Use Designation: High-Bay Luminaires for Commercial and Industrial Buildings

<sup>1</sup>Dimming with standard 0-10V control system or wall dimmers. Dimming complies with IEC60929 Annex E. Fixture may not be compatible with all dimmers. Visit [www.topaz-usa.com/led-dimmer-compatibility](http://www.topaz-usa.com/led-dimmer-compatibility) for up-to-date dimmer compatibility information.

HID equivalent and typical mounting height may vary and depend on application requirements.

Specifications subject to change without prior notice.

**WARNING:** Some products included in this specification sheet may be subject to the warning requirements of California's Proposition 65. Please refer to product packaging for more information.

## LED Round High Bay SATELLITE PRO

### MOTION SENSOR ACCESSORIES (Sold Separately)

Catalog Number	Order Code	UPC	Description
F-LUHB/MS/G3	72721	751338038493	Motion Sensor for Satellite Pro High Bay
F-LUHB/RC/G3	72725	751338038509	*Remote Control for Motion Sensor (order one per project)

\*Remote control will not operate Satellite Pro High Bay without motion sensor.



#### MOTION SENSOR PRE-PROGRAMMED SETTINGS

Brightness	Sensitivity	Hold time	Daylight Threshold	Stand-by Dimming Level	Stand-by Dimming Period
100%	100%	5 Minutes	Disabled	10%	1 Minute

### SAMPLE APPLICATION

Sample Application	Brightness	Sensitivity	Hold Time	Daylight Threshold	Stand-by Dimming Level	Stand-by Dimming Period	Comments
Warehouse (no skylights)	100%	100%	5 minutes	Disabled	10%	30 minutes	With the assumption that personnel will only be in an area briefly, the hold time is short and the stand-by level is set low for maximum savings. After 30 minutes, the area will go to off, ensuring that the lights turn off when the facility goes completely vacant.
Warehouse (with skylights)	100%	100%	5 minutes	100 LUX	10%	30 minutes	Same as above, but with the daylight threshold enabled so that the lights will turn off when daylight is available. The threshold can be set to lower or higher levels according to the specific needs.
Food handling area	100%	100%	20 minutes	Disabled	50%	30 minutes	With the assumption that personnel may spend an extended period of time in a location without moving around a lot, the hold time is relatively long. The stand-by level is set higher so that areas adjacent to the work area are more fully lit. With the 30-minute stand-by period, the area will eventually turn off fully after workers have vacated.
24-hour factory	100%	75%	30 minutes	Disabled	30%	+ Infinity	The detection area is set 75% (or perhaps even lower) so that adjacent areas are not unnecessarily lit. Because workers may be stationary for extended times, the hold time is set to 30 minutes. Because the facility never goes completely vacant, the stand-by period is set to infinity. The facility will never go dark - it will remain at 30% in any area that is vacant.

### FIXTURE CAPABILITIES (REMOTE CONTROL REQUIRED)

Brightness	Sensitivity	Hold Time	Daylight Threshold	Stand-by Dimming Level	Stand-by Dimming Period
Sets the light brightness during the hold time.	Sets the size of the detection area	The time period that the fixture will remain at full after motion is no longer detected	The light level above which the fixture will turn off and stay off regardless of motion. Typically only used in outdoor or other locations with substantial natural light	The level that the fixture goes to after the hold time is complete. If the stand-by period is 0 sec, the fixture will turn off	The time period that the fixture will remain at the stand-by level before turning off. The stand-by period starts after the hold period
70%, 80%, 90%, 100%	20%, 50%, 75%, 100%	10 sec, 1 min, 5 min, 10 min, 15 min, 20 min, 30 min, 60 min	(MOON ICON, 10LUX, 30LUX, 50LUX, 100LUX, 300LUX, 500LUX, SUN ICON)	0%, 10%, 30%, 50%	+infinity, 1 min, 30 min, 60 min

## LED Round High Bay SATELLITE PRO

### EMERGENCY BATTERY ACCESSORY (Sold Separately)

Catalog Number	Order Code	UPC	Input Wattage	Output Wattage	Input Current
F-LUHB/EMKIT	72728	751338038523	8.5W	40W	150mA

### FEATURES

- 5,200 fixture lumens at 130 LPW
- Meets NFPA 101, NFPA 70 safety standards
- Not for use with F-LUHB/MS/G3 motion sensor

### GENERAL SPECIFICATIONS

**Input Voltage, Frequency:** 120-277V, 50/60Hz  
**Emergency Duration/Run Time:** 90 minutes  
**Recharge Time:** 24 hours  
**Battery Type:** LiFePO4 12.4 6600mA, 84.48Wh  
**Typical Life Cycles:** 1,000  
**IP Rating:** IP65  
**Ambient Operating Temperature:** 32°F to 122°F  
**Housing Construction:** Color-coated sheet  
**Compliance Testing:** Manual with included remote control



### DIMMING SPECIFICATIONS

Compatible with Round High Bay fixtures with a maximum load rating of 300W. EM KIT requires connection to fixture 0-10V dimming.



Note: Not approved for use in applications requiring NSF certification.

### WIRING CONNECTION

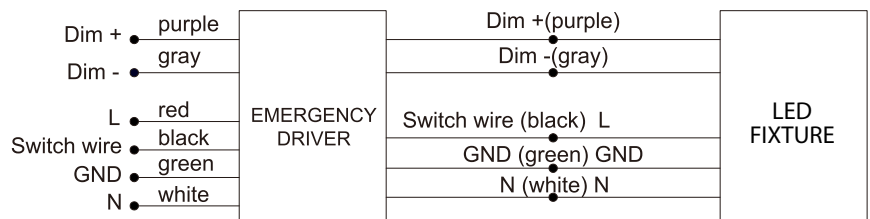

### DIMENSIONS / WEIGHTS

Catalog Number	(A)	(B)	(C)	Weight
F-LUHB/EMKIT	8.1"	9.4"	4.3"	5.7 Lbs.

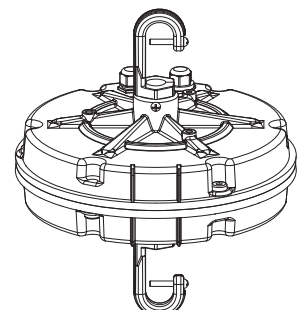
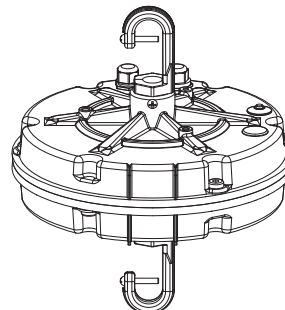
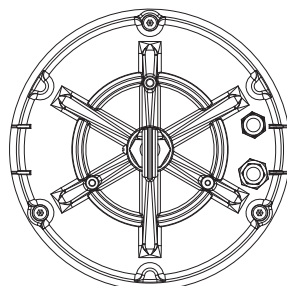
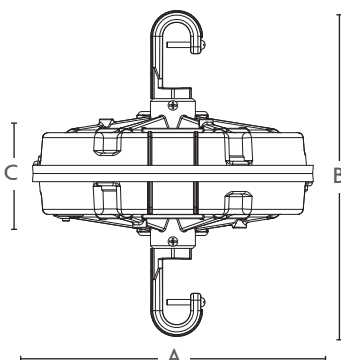

**LED Round High Bay**  
SATELLITE PRO

**F-LUHB/240/5K/G3 and F-LUHB/240/5K/HV/G3**

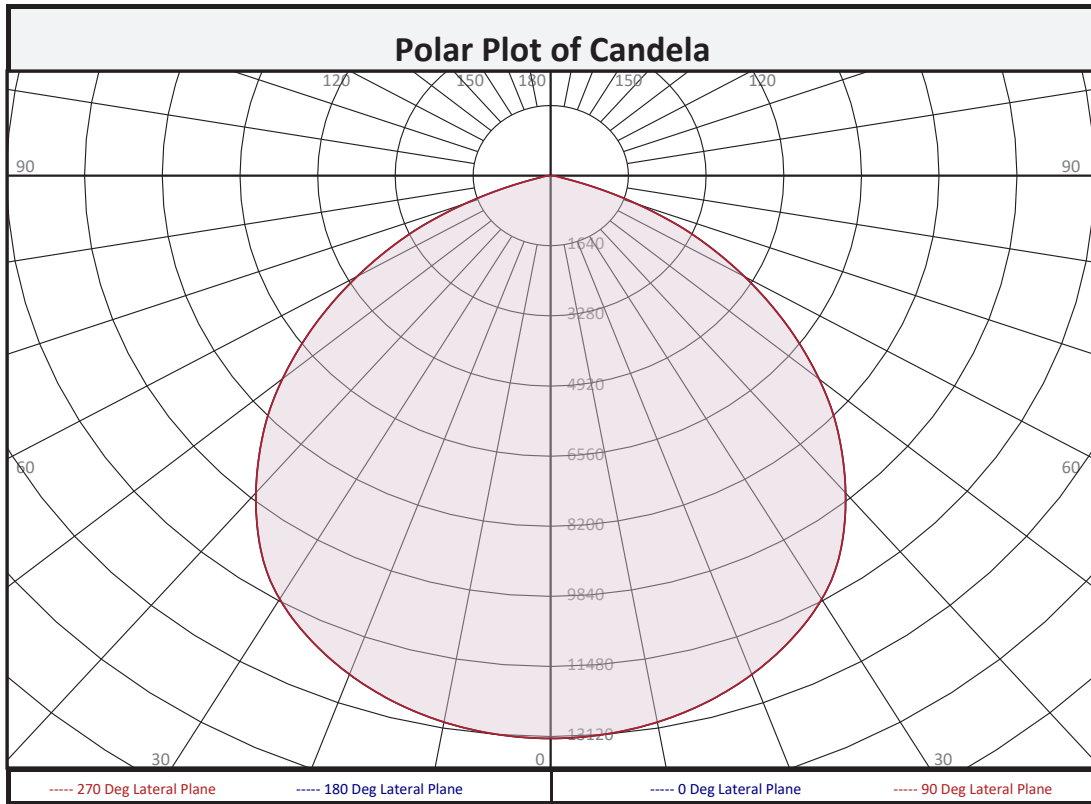

Zonal Flux Summary											
Zone (Deg Vert)	Flux (Lumens)	Percent of Total		Zone (Deg Vert)	Flux (Lumens)	Percent of Total		Zone (Deg Vert)	Flux (Lumens)	Percent of Total	
0-10	1248	3.7%		90-100	0.0	0.0%		0-20	4848	14.6%	
10-20	3600	10.8%		100-110	0.0	0.0%		0-30	10373	31.1%	
20-30	5525	16.6%		110-120	0.0	0.0%		0-40	17029	51.1%	
30-40	6657	20.0%		120-130	0.0	0.0%		0-60	29063	87.2%	
40-50	6616	19.9%		130-140	0.0	0.0%		0-80	33218	99.7%	
50-60	5418	16.3%		140-150	0.0	0.0%		10-90	32067	96.3%	
60-70	3313	9.9%		150-160	0.0	0.0%		20-50	18797	56.4%	
70-80	842.1	2.5%		160-170	0.0	0.0%		40-90	16286	48.9%	
80-90	97.7	0.3%		170-180	0.0	0.0%		60-90	4252	12.8%	
0-90	33315	100.0%		90-180	0.0	0.0%		0-180	33315	100.0%	

Height(ft)	Illuminance at Nadir (fc)	Ground-level distance to half-of-nadir illuminance (ft)	
		0-180 deg	90-270 deg
15.0	58.5	19.28	19.28
20.0	32.9	25.71	25.71
25.0	21.1	32.14	32.14
30.0	14.6	38.57	38.57
35.0	10.7	45.00	45.00
40.0	8.2	51.42	51.42

**LED Round High Bay**  
SATELLITE PRO

**F-LUHB/150/5K/G3 and F-LUHB/150/5K/HV/G3**

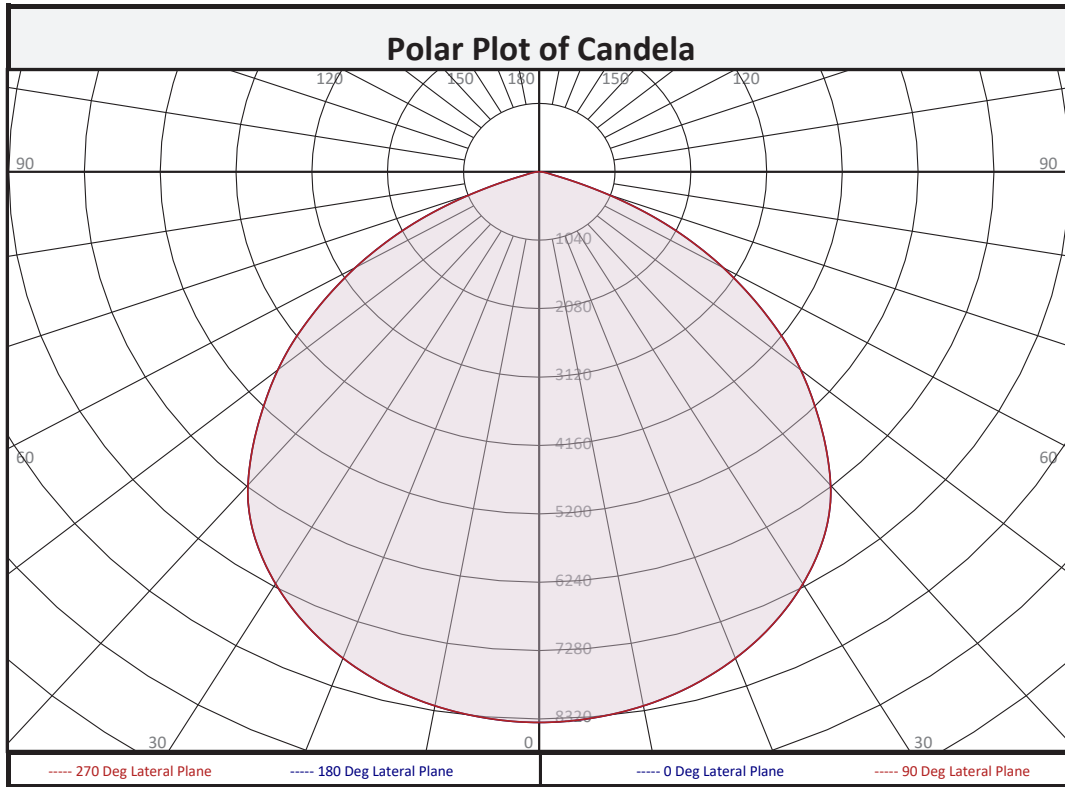

Zonal Flux Summary										
Zone (Deg Vert)	Flux (Lumens)	Percent of Total		Zone (Deg Vert)	Flux (Lumens)	Percent of Total		Zone (Deg Vert)	Flux (Lumens)	Percent of Total
0-10	793.5	3.8%		90-100	0.0	0.0%		0-20	3078	14.8%
10-20	2285	11.0%		100-110	0.0	0.0%		0-30	6576	31.6%
20-30	3498	16.8%		110-120	0.0	0.0%		0-40	10820	52.0%
30-40	4244	20.4%		120-130	0.0	0.0%		0-60	18434	88.5%
40-50	4212	20.2%		130-140	0.0	0.0%		0-80	20765	99.7%
50-60	3402	16.3%		140-150	0.0	0.0%		10-90	20029	96.2%
60-70	1943	9.3%		150-160	0.0	0.0%		20-50	11954	57.4%
70-80	388.3	1.9%		160-170	0.0	0.0%		40-90	10002	48.0%
80-90	57.2	0.3%		170-180	0.0	0.0%		60-90	2388	11.5%
0-90	20822	100.0%		90-180	0.0	0.0%		0-180	20822	100.0%

Circle of Light Plot			
Height(ft)	Illuminance at Nadir (fc)	Ground-level distance to half-of-nadir illuminance (ft)	
		0-180 deg	90-270 deg
10.0	83.7	12.82	12.82
14.0	42.7	17.95	17.95
18.0	25.8	23.07	23.07
22.0	17.3	28.20	28.20
26.0	12.4	33.33	33.33
30.0	9.3	38.46	38.46