



## 360° Dual-Technology PIR/Ultrasonic Low Voltage Occupancy Sensor

**Model No: MDC-50L**

### Description

The MDC-50L 360° Dual-Technology Occupancy Sensor combines advanced passive infrared (PIR) and ultrasonic technology into one unit. The combined technologies help to avoid false triggering. Selectable operation modes allow the sensor to turn back on and hold it on as long as either or both technologies detect occupancy. After no movement is detected for the selected time delay, the lights switch off. \* The MDC-50L operated on 24V supplied by MMP-24 power pack (sold separately).

### Features

- Passive Infrared Technology(PIR)/Ultrasonic
- 360 ° field of view
- 1600sqft PIR coverage 1000sqft ultrasonic coverage
- Time Delay is adjustable from 5 seconds to 30 minutes
- LED compatible up to 150W
- Adjustable sensitivity settings
- Light level is adjustable.

### Testing & Code Compliance



### Specifications

Voltage .....	24VDC
Current Consumption .....	20mA
Power Supply .....	MPP-24 Power Pack
Operating Temperature .....	32°to 131°F (0°to 55°C)
Adjustment Time Delay .....	5 Sec. to 30 Min.
Test Mode .....	delaytime is 5 sec. lasts 30 Min.
	at each time by setting
PIR Adjustment .....	50% or 100% (DIP switch 1)
Ultrasonic Adjustment .....	Min to Max (trimpot 1)
Light Level Adjustment .....	100 Lux - daylight (trimpot 2)
PIR Coverage .....	1200ft <sup>2</sup>
Ultrasonic Coverage .....	1000ft <sup>2</sup>
Standards and Certifications .....	UL Listed
Warranty .....	2 years

### Coverage Area

The MDC-50L provides a 360° coverage pattern. The coverage shown represents walking motion at mounting height of 9 feet. For building spaces with lower levels of activity or with obstacles and barriers ,coverage size may decrease.

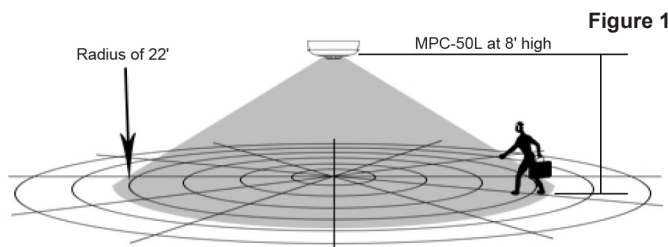

## WIRING DIRECTIONS

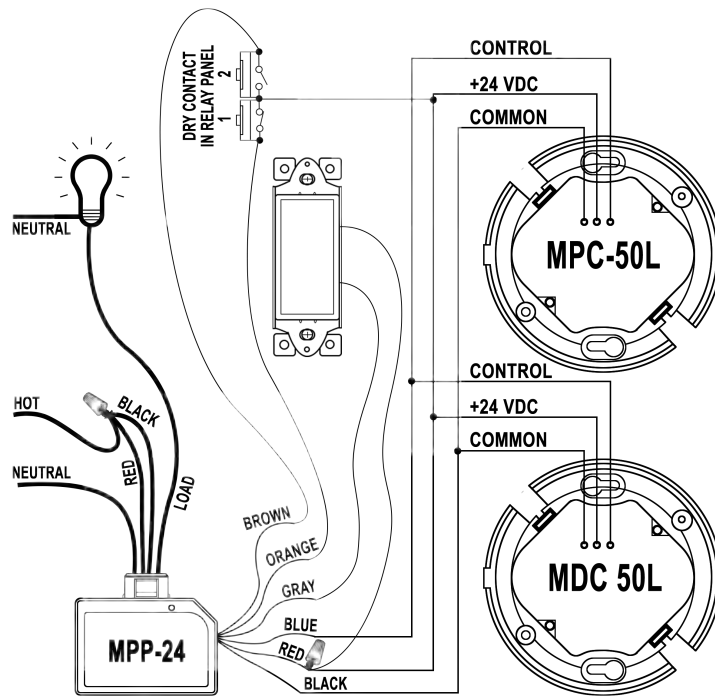

Figure 2

## Mounting

### Using an Octagonal Junction Box

1. Pull the high voltage wires into the J-Box through the conduit knockout.
2. Connect the high voltage wires to the appropriate terminals on the sensor.
3. Loosen the appliance mounting screws attached to the J-Box.
4. Align the sensor in the J-Box so that the mounting screws on the box match the key holes on the sensor's rear housing.
5. Push the sensor up into the J-Box and twist it so that the mounting screws are seated in the keyhole slots.
6. Tighten the two screws to secure the sensor to the J-Box.
7. Snap the front cover onto the sensor(see Figure 3)

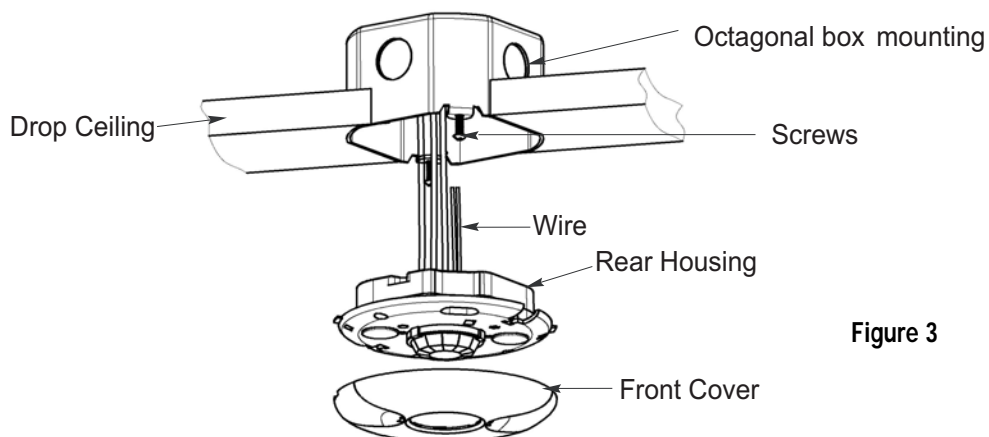

Figure 3

**There is a 40-second warm-up period when power is first applied.** The sensors are factory preset to allow for quick installation in most applications. To make adjustments, open the Front Cover Set the DIP Switch to the desired settings. See "DIP Switch Setting" below.

## Sensor Adjustment

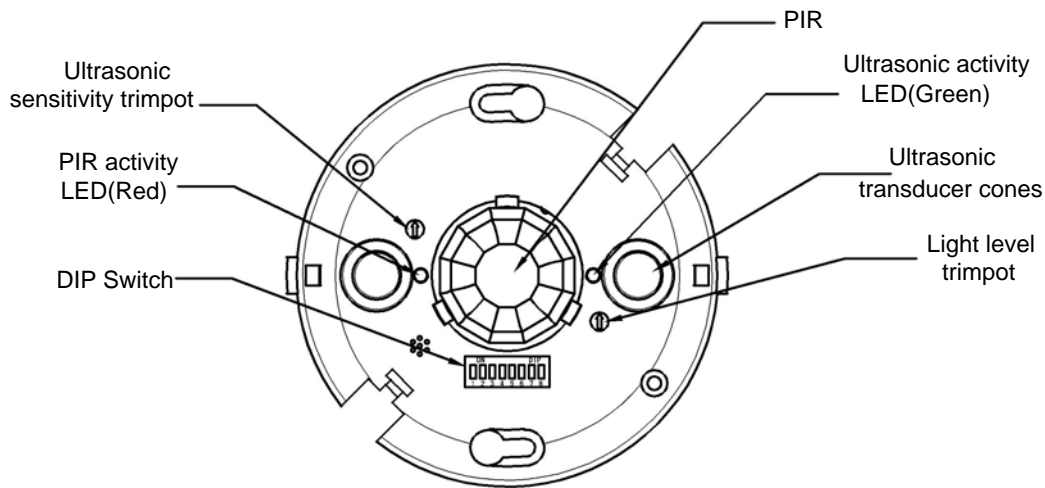

Figure 4

### Ultrasonic Sensitivity Adjustment Trimpot 1

Adjustable: Minimum to Maximum (clockwise)

Note: Turn toward right for greater room space.

Turn toward left to avoid false alert in smaller room and near the door way or heat source.



Ultrasonic

### Ambient Light Level Adjustment Trimpot 2

Adjustable: 100Lux to daylight ( clockwise)



Light

## DIP Switch Setting

The MDC-50V has 8 DIP switches under the cover. They are used to set PIR sensitivity, time delay, override and trigger mode feature settings.

Trigger Mode	Initial Trigger	Maintain Load Output	2	3	4
Option 1	Both	Either	↓	↓	↓
Option 2	Either	Either	↓	↓	↑
Option 3	PIR	Either	↓	↑	↓
Option 4	PIR	PIR	↓	↑	↑
Option 5	Ultrasonic	Ultrasonic	↑	↓	↓
Option 6	Both	Both	↑	↓	↑

PIR Sensitivity	1
50%	↓
100%	↑

Override	8
Disabled	↓
Enabled	↑

Time Delay	5	6	7
5 Sec/Autoset	↓	↓	↓
30 Seconds	↓	↓	↑
5 Minutes	↓	↑	↓
10 Minutes	↓	↑	↑
15 Minutes	↑	↓	↓
20 Minutes	↑	↓	↑
25 Minutes	↑	↑	↓
30 Minutes	↑	↑	↑

↓=OFF ↑=ON ◀=Fac

### PIR Sensitivity setting: Switch 1

50%, sensor's coverage is smaller, just about half of the widest range.  
100%, the maximum range of sensor's PIR coverage is 1600 square feet.

### Trigger Mode: Switches 2, 3, 4

The sensor has 6 trigger options, set with DIP switches 2, 3 and 4.  
In the trigger mode DIP switch setting table:

- **Both** requires motion detection by the PIR and the Ultrasonic.
- **Either** requires motion detection by only one technology.
- **PIR** requires motion detection by the PIR.
- **Ultrasonic** requires motion detection by the Ultrasonic.

### Time Delay: Switches 5, 6, 7

The sensor will hold the lights on as long as occupancy is detected. The time delay countdown starts when no motion is detected. After no motion is detected for the length of the time delay, the sensor will turn the lights off.

### Override: Switch 8

To override all sensor functions, set to ON position ( DIP Swicth 8 ).