

USER MANUAL

CENTRIFUGAL INLINE FANS

VKM / VKMZ / VC SERIES

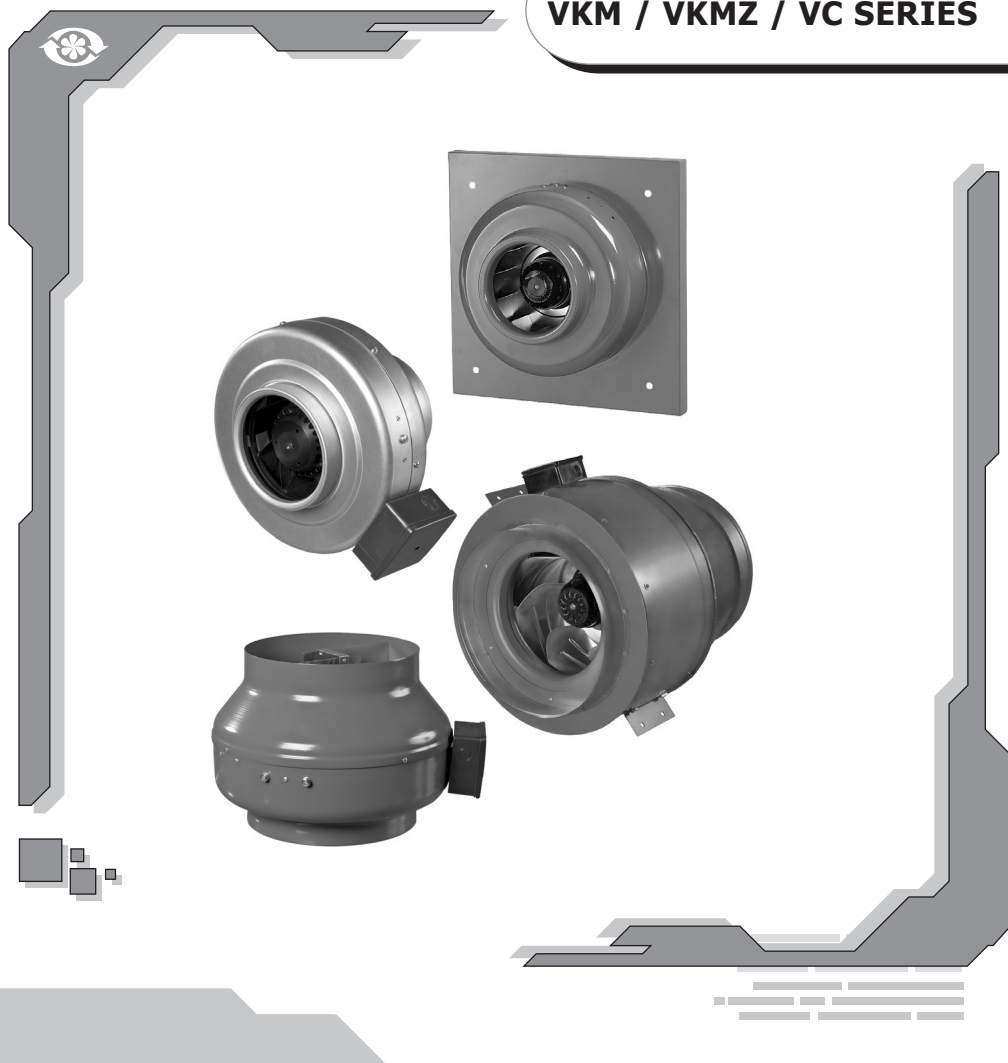

CONTENT

Use	3
Delivery set	3
Structural designation key	3
Main technical data	4
Safety requirements	10
Fan design	10
Connection to power mains	12
Maintenance	13
Storage requirements	14
Manufacturer's warranty	14
Acceptance certificate	15



USE

The present user manual contains the product description, technical data, operation, installation and mounting guidelines for the centrifugal inline fans of VENTS VKM, VKMz, VC series, hereinafter referred to as the fan. The fans are designed for ventilation of domestic, public and manufacturing premises heated during winter.

Transported air must not contain dust, solid and sticky particles and fibrous materials.

The transported air temperature must be within the limits stated in fig. 1, 3, 5.

The fan is designed for horizontal or vertical mounting in a round air duct and are used both for extract and supply ventilation.

The fan is rated for continuous operation always connected to power mains. The fan must be grounded. Ingress Protection Rating IPX4.

DELIVERY SET

The delivery set includes:

- fan - 1 item;
- fixing bracket - 2 items (for series VKM, VKMC, VKM Q, VKMz), for VKM E series - 1 item;
- user manual;
- packing box.

STRUCTURAL DESIGNATION KEY

X X X X X

P - smooth speed controller

Un - speed controller with temperature sensor

E - equipped with energy-saving motor

Q - low-watt motor

Exhaust spigot diameter

100; 125; 150; 200; 250; 315; 355; 400; 450 mm

S - high-powered motor

Fan name:

VKM - inline centrifugal fan in metal casing

VKMz - inline centrifugal fan in galvanized steel casing

VC-VK - inline centrifugal extract fan for outside installation

VC-PK - inline centrifugal supply fan for installation into air duct

VC-PN - inline centrifugal supply fan for outside installation

VCz-VN - inline centrifugal extract fan for outside installation in galvanized steel casing

VKM 150 - inline centrifugal supply fan in metal casing for mounting into Ø 150 mm air duct.

VKMS 315 - inline centrifugal supply fan in metal casing with high-powered motor for mounting into Ø 315 mm air duct.

VKM 250 Un - inline centrifugal supply fan in metal casing for mounting into Ø 250 mm air duct with the control logic based on the temperature sensor, equipped with a temperature sensor.

VKMz 200 - inline centrifugal fan in galvanized steel casing for mounting into Ø 200 mm air duct.

VKMz 160P - inline centrifugal fan in galvanized steel for mounting into Ø 160 mm air duct, with smooth speed control function.

VC-VK 250 - inline centrifugal extract fan for mounting into Ø 250 mm air duct.

VC-VN 315 - inline centrifugal extract fan for outside mounting into Ø 315 mm air duct.

VC-PK 125 - inline centrifugal supply fan for mounting into Ø 125 mm air duct.

VC-PN 100 - inline centrifugal supply fan for outside mounting into Ø 100 mm air duct.

VCz-VN 150 - inline centrifugal extract fan in galvanized steel casing for outside mounting into Ø 150 mm air duct.

MAIN TECHNICAL DATA

The fan designation, parameters and connecting dimensions are shown in tables 1, 2, 3, 4, 5, 6, 7, 8 and in fig. 1, 2, 3, 4, 5, 6, 7, 8, 9, 10, 11, 12.

Due to the constant improvements the design of some models may slightly differ from those described in this manual. The wiring diagram and terminal designation may also differ from the description in this manual.

Table 1

Type	Dimensions [mm]								Weight [kg]	Fig. no.
	Ø D	Ø D1	B	B1	L	L1	L2	L3		
VKM 100 E	100	204	-	-	195	20	20	258	3,9	1
VKM 100 Q	98	254	298	258	205	20	25	30	4,2	2
VKM 100	98	254	298	258	205	20	25	30	4,4	2
VKM 125 E	125	204	-	-	195	20	20	258	3,9	1
VKM 125 Q	123	254	298	258	205	20	25	30	4,1	2
VKM 125	123	254	298	258	205	20	25	30	4,3	2
VKM 150 Q	149	304	349	309	200	20	25	30	5,4	2
VKM 150	149	340	349	309	220	25	25	30	5,4	2
VKMS 150	149	340	386	346	226	20	20	40	5,7	2
VKM 160 Q	159	304	349	309	200	20	25	30	5,4	2
VKM 160	159	304	357	317	220	25	25	30	5,6	2
VKMS 160	159	340	357	346	226	20	20	40	5,7	2
VKM 200	198	344	390	350	240	25	29	40	6,6	2
VKMS 200	198	344	390	350	250	25	29	40	6,7	2
VKM 250 Q	248	344	390	350	249	25	31	40	7,1	2
VKM 250	248	344	390	350	249	25	31	40	7,3	2
VKM 315	314	404	454	414	260	25	40	40	8,1	2
VKMS 315	314	404	454	414	288	25	40	40	8,2	2
VKM 355 Q	353	460	522	522	506	60	60	70	12,8	3
VKM 400	398	570	634	570	506	60	60	70	20,0	3
VKM 450	448	608	663	634	570	60	60	80	30,0	3

Allowable deviation of the rated voltage: ±10%

Табл.2

	VKM 100 E	VKM 100 Б	VKM 100	VKM 125 E	VKM 125 Б	VKM 125	VKM 150 Б	VKM 150	VKMS 150	VKM 160 Б
Voltage, 50 Hz [V]	230	230	230	230	230	230	230	230	230	230
Power [W]	27	60	73	27	60	75	75	98	116	73
Current [A]	0,13	0,37	0,32	0,13	0,37	0,33	0,33	0,43	0,52	0,33
Max. air capacity [m ³ /h]	180	210	270	240	255	355	470	55	645	470
Rotation per minute [min ⁻¹]	2745	2620	2830	2780	2535	2800	2515	2705	2625	2500
Noise level at 3 m distance [dBA]	32	36	47	32	36	47	46	47	50	46
Max. transported air temperature [°C]	-25 +55	-25 +55	-25 +55	-25 +55	-25 +55	-25 +55	-25 +55	-25 +55	-25 +55	-25 +55
Ingress Protection	IP X4	IP X4	IP X4	IP X4	IP X4	IP X4	IP X4	IP X4	IP X4	IP X4

	VKM 160	VKMS 160	VKM 200	VKMS 200	VKM 250 Б	VKM 250	VKM 315	VKMS 315	VKM 355 Б	VKM 400	VKM 450
Voltage, 50 Hz [V]	230	230	230	230	230	230	230	230	230	230	230
Power [W]	98	115	154	193	158	194	171	296	233	460	665
Current [A]	0,43	0,52	0,67	0,84	0,69	0,85	0,77	1,34	1,06	2,23	2,89
Max. air capacity [m ³ /h]	555	645	950	1100	1190	1310	1400	1880	2210	3050	5260
Rotation per minute [min ⁻¹]	2660	2650	2375	2780	2315	2790	2600	2720	1375	1370	1265
Noise level at 3 m distance [dBA]	47	50	48	51	52	52	52	54	58	61	65
Max. transported air temperature [°C]	-25 +55	-25 +55	-25 +50	-25 +45	-25 +50	-25 +50	-25 +50	-25 +45	-25 +45	-25 +80	-25 +70
Ingress Protection	IP X4	IP X4	IP X4	IP X4	IP X4	IP X4	IP X4	IP X4	IP X4	IP X4	IP X4

VKM 100 E - VKM 125 E

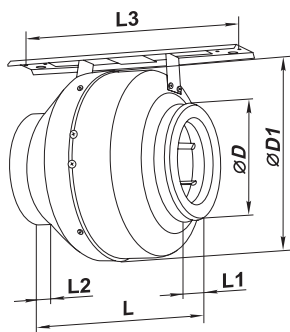

Fig. 1

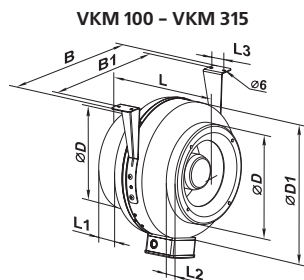

Fig. 2

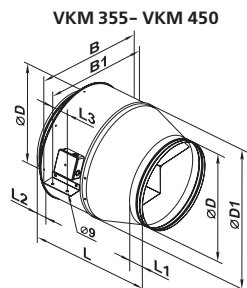
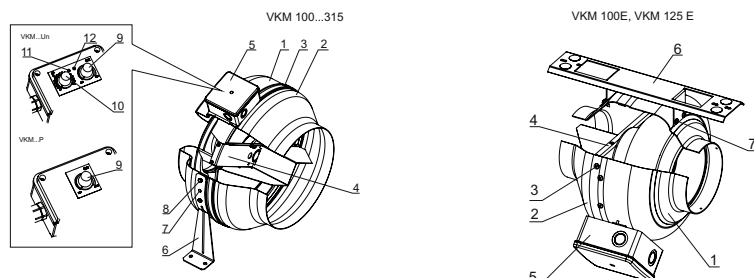

Fig. 3

Table. 3

	VKMz 100 B	VKMz 100	VKMz 125 B	VKMz 125	VKMz 150	VKMz 160	VKMz 200 B	VKMz 200	VKMz 250 B	VKMz 250	VKMz 315 B	VKMz 315
Voltage, 50 Hz [V]	230	230	230	230	230	230	230	230	230	230	230	230
Power [W]	60	72	60	78	75	78	139	157	134	152	1513	185
Current [A]	0,37	0,32	0,37	0,34	0,33	0,34	0,61	0,69	0,59	0,66	0,66	0,81
Max. air capacity [m ³ /h]	195	250	230	330	455	455	840	1000	980	1070	1330	1540
Rotation per minute [min ⁻¹]	2670	2820	2605	2820	2770	2760	2790	2740	2785	2785	2680	2730
Noise level at 3 m distance [dBA]	35	46	35	46	46	46	48	50	51	52	52	53
Max. transported air temperature [°C]	-25 +55	-25 +55	-25 +55	-25 +55	-25 +55	-25 +55	-25 +55	-25 +55	-25 +55	-25 +55	-25 +55	-25 +55
Ingress Protection	IP X4	IP X4	IP X4	IP X4	IP X4	IP X4	IP X4	IP X4	IP X4	IP X4	IP X4	IP X4

Allowable deviation of the rated voltage: $\pm 10\%$



- 1 - casing;
2 - cover;
3 - screws;
4 - inner fixing bracket;
5 - terminal box;
6 - outer fixing bracket;
7 - screws;

- 8 - bolt;
9 - fan speed control knob;
10 - temperature control knob;
11 - fan on/off LED light;
12 - thermostat LED light.

Fig. 4

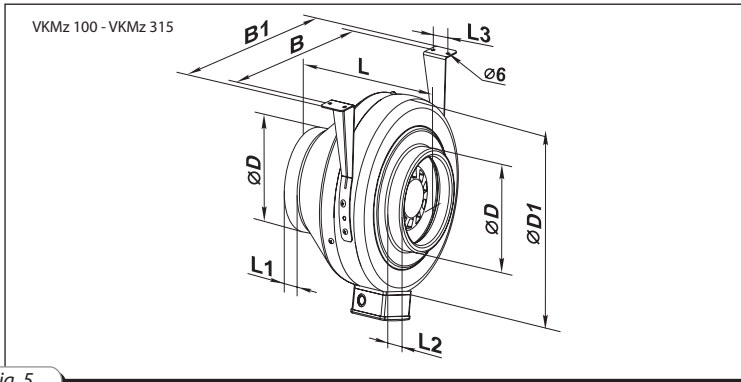

Fig. 5

Type	Dimensions [mm]								Weight [kg]
	Ø D	ØD1	B	B1	L	L1	L2	L3	
VKMz 100 Q	98	237	253	293	202	23	22	30	3,1
VKMz 100	98	237	253	293	202	23	22	30	3,2
VKMz 125 Q	123	237	253	293	202	23	22	30	3,1
VKMz 125	123	237	253	293	202	23	22	30	3,15
VKMz 150	148	278	294	334	200	25	23	30	3,8
VKMz 160	158	278	294	334	200	25	23	30	3,8
VKMz 200 Q	198	332	340	380	245	25	29	40	4,2
VKMz 200	198	332	340	380	245	25	29	40	4,4
VKMz 250 Q	249	332	340	380	213	25	29	40	4,1
VKMz 250	249	332	340	380	213	25	29	40	4,3
VKMz 315 Q	315	402	410	450	308	33	55	40	5,5
VKMz 315	315	402	410	450	308	33	55	40	5,7

- 1 - casing;
- 2 - cover;
- 3 - screws;
- 4 - inner fixing bracket;
- 5 - terminal box;
- 6 - outer fixing bracket;
- 7 - screws;
- 8 - bolt;
- 9 - fan speed control knob;
- 10 - temperature control knob;
- 11 - fan on/off LED light;
- 12 - thermostat LED light.

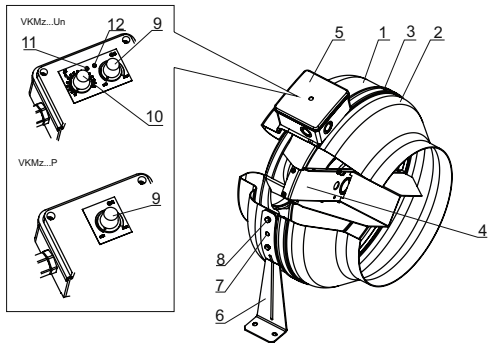

Fig. 6

Table 5

Type	Voltage, 50 Hz [V]	Power [W]	Current [A]	Max. air capacity [m ³ /h]	Rotation per minute [min ⁻¹]	Noise level at 3 m distance [dBA]	Max. transported air temperature [°C]
VC 100 Q	230	60	0,37	210	2620	36	-25 +55
VC 100	230	73	0,32	270	2830	47	-25 +55
VC 125	230	60	0,37	255	2535	36	-25 +55
VC 125 Q	230	75	0,33	355	2800	47	-25 +55
VC 150	230	98	0,43	555	2705	47	-25 +55
VC 160	230	98	0,43	555	2660	47	-25 +55
VC 200	230	154	0,67	950	2375	48	-25 +50
VCS 200	230	193	0,84	1100	2780	51	-25 +45
VC 250 Q	230	158	0,69	1190	2315	52	-25 +50
VC 250	230	194	0,85	1310	2790	52	-25 +50
VC 315	230	171	0,77	1400	2600	52	-25 +55
VCS 315	230	296	1,34	1880	2720	54	-25 +45

Allowable deviation of the rated voltage: $\pm 10\%$

VC-VK

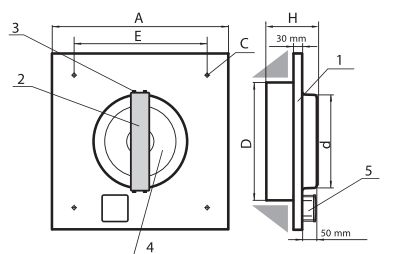

- 1 - casing;
2 - fixing bracket;
3 - screws;

- 4 - motor-impeller block;
5 - terminal box;

VC-VN

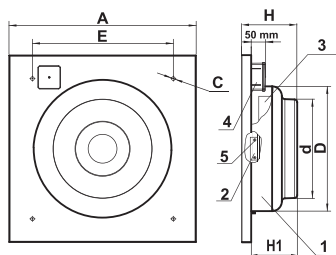

- 1 - casing;
2 - fixing bracket;
3 - motor-impeller block;

- 4 - terminal box.
5 - screws.

Fig. 7

Fig. 8

VC-PN

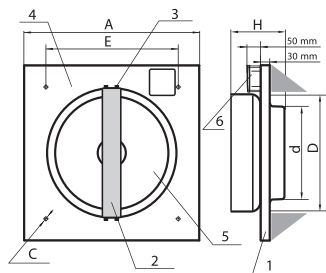

- 1 - casing;
2 - fixing bracket;
3 - screws;

- 4 - base plate;
5 - motor-impeller block;
6 - terminal box.

VC-PK

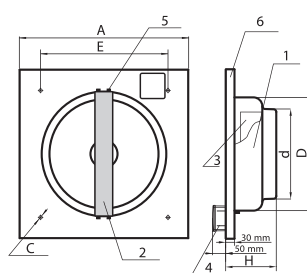

- 1 - casing;
2 - fixing bracket;
3 - motor-impeller block;

- 4 - terminal box;
5 - screws;
6 - base plate.

Fig. 9

Fig. 10

Table 6

Type	Dimensions [mm]						Weight [kg]
	C	D	d	A	H/H1	E	
VC 100 Q \ VC 100	10	249	98	435	150 / 120	330	3,24
VC 125 Q \ VC 125	10	249	123	435	150 / 120	330	3,24
VC 150	10	249	149	435	153 / 123	330	4,26
VC 160	10	249	159	435	153 / 123	330	4,3
VC 200 \ VCS 200	12	339	164	595	171 / 141	450	6,1
VC 250 Q \ VC 250	12	339	164	595	172 / 142	450	5,9
VC 315 \ VCS 315	12	339	315	595	209 / 179	450	7,2

Table 7

Type	Voltage, 50 Hz [V]	Power [W]	Current [A]	Max. air capacity [m ³ /h]	Rotation per minute [min ⁻¹]	Noise level at 3 m distance [dBA]	Max. transported air temperature [°C]	Ingress Protection
VCz 100Q-VN	230	60	0,37	195	2670	35	-25 +55	IP X4
VCz 100-VN	230	72	0,32	250	2820	46	-25 +55	IP X4
VCz 125Q-VN	230	60	0,37	230	2605	35	-25 +55	IP X4
VCz 125-VN	230	78	0,34	330	2820	46	-25 +55	IP X4
VCz 150-VN	230	75	0,33	455	2770	46	-25 +55	IP X4
VCSz 150-VN	230	97	0,43	720	2760	46	-25 +55	IP X4
VCz 160-VN	230	78	0,34	455	2760	46	-25 +55	IP X4
VCSz 160-VN	230	97	0,43	720	2765	46	-25 +55	IP X4
VCz 200Q-VN	230	139	0,61	840	2790	48	-25 +50	IP X4
VCz 200-VN	230	157	0,69	1000	2740	50	-25 +50	IP X4
VCSz 200-VN	230	193	0,84	1150	2780	51	-25 +50	IP X4
VCz 250Q-VN	230	134	0,59	980	2785	51	-25 +50	IP X4
VCz 250-VN	230	152	0,66	1070	2765	52	-25 +50	IP X4
VCSz 250-VN	230	175	0,77	1185	2745	52	-25 +50	IP X4
VCz 315Q-VN	230	151	0,66	1330	2680	53	-25 +50	IP X4
VCz 315-VN	230	185	0,81	1540	2730	53	-25 +50	IP X4
VCSz 315-VN	230	270	1,18	1755	2730	53	-25 +50	IP X4

 Allowable deviation of the rated voltage: $\pm 10\%$
Table 8

Type	Dimensions [mm]						Weight [kg]
	C	D	d	A	H/H1	E	
VCz 100Q-VN VCz 100-VN	6	235	98	310	115/90	295	3,2
VCz 125Q-VN VCz 125-VN	6	235	123	310	115/90	295	3,2
VCz 150-VN VCSz 150-VN	6	275	148	400	128/92	385	4,26
VCz 160-VN VCSz 160-VN	6	275	159	400	128/92	385	4,3
VCz 200Q-VN	6	333	198	400	130/115	385	5,3
VCz 200-VN VCSz 200-VN	6	333	198	400	130/115	385	5,5
VCz 250Q-VN	6	333	248	400	134/114	385	7,1
VCz 250-VN VCSz 250-VN	6	333	248	400	134/114	385	7,8
VCz 315Q-VN VCz 315-VN	6	400	313	460	172/142	445	8
VCSz 315-VN	6	400	313	460	194/142	445	8,5

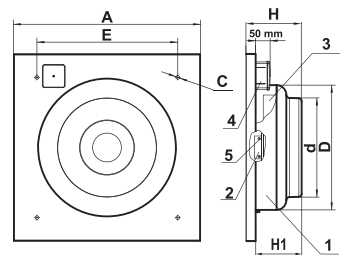
VCz-VN

- 1 - casing;
- 2 - fixing bracket;
- 3 - motor-impeller block;

- 4 - terminal box;
- 5 - screws.

Fig. 11

SAFETY REQUIREMENTS

Take steps to prevent ingress of smoke, carbon monoxide and other combustion products into the room through open chimney flues or other fire-protection devices. Mounting and maintenance of the fan are allowed only by duly qualified electricians in compliance with valid rated norms.

Disconnect the fan from power mains prior to any servicing and repair works. Before connecting the fan to power mains check the fan for any visible damages of impeller and casing. The fan casing must not contain any foreign objects which can damage the impeller blades.



WARNING: Do not use the fan in explosive or fire-hazardous environment. Misuse of the fan or any unauthorized modification is not allowed.

If the fan is subjected to water sprays from all directions (IPX4), it must be extra protected against water ingress.

Possible options:

1. Connect a straight air duct section at least 1 m long to the intake spigot in case of horizontal fan installation.
2. In case of any installation option install an outer hood on the intake spigot.

FAN DESIGN

VKM and VKMz fan (fig. 4, 6) consists of the casing 1, the motor-impeller block that is attached to the fixing bracket 4, the cover 2 that is fixed to the casing with screws 3 (the casing spigot diameter and the cover diameter are equal to the connected air duct diameter), the terminal block 5 that incorporates a terminal block and a capacitor (fig. 1, 5) and enables connection of the fan to power mains.

The fan models with the speed controller and thermostat are equipped with a speed control knob 9, a thermostat control knob 10, a fan on/off LED light indicator 11 and a thermostat LED light indicator 12 that are located on the terminal box cover.

The fan models with the speed controller are equipped with a speed control knob 9 which is located on the terminal box 5 cover.

The fan models with a speed controller and a speed controller with a thermostat are connected to power mains through a power cable with a plug.

The fan is designed for vertical mounting. The air direction in the system must match the pointer direction on the fan casing.

Mounting sequence for fixing the fan on the wall or to the ceiling:

- remove the bolt from the casing 1 and install the fixing brackets in such a way so that the holes on the fixing brackets are aligned with the heads of the screws 3;
- fix the fixing brackets on the casing with bolts;
- drill the holes in the mounting surface to match the fitment holes of the fixing brackets;
- fix the fan with the screws;
- connect the air ducts of the respective size to the fan and fix them with clamps.

Temperature and speed controller:

This option is available for the models VKM Un, VKMz Un. The temperature and speed controller is designed for air temperature control and fan speed control depending on ambient air temperature.

The fan models VKM Un, VKMz Un are equipped with an external temperature sensor fixed on 4 m cable. The cover of the terminal block (fig. 4, 6) incorporates the following controls:

- fan speed control knob 9;
- thermostat control knob 10 to set the thermostat temperature threshold;
- on/off LED light indicator 11;
- thermostat LED light indicator 12.

Control logic of VKM Un, VKMz Un fans.

Set the thermostat temperature threshold with the thermostat control knob 10. Turn the fan on and then set the fan speed with a speed control knob 9. The fan on/off light indicator 11 glows.

The controller switches the fan to the maximum speed (maximum air flow) as the temperature rises and crosses the thermostat setpoint. The thermostat light indicator 12 glows if the temperature is above the thermostat setpoint. After the temperature falls 2°C below the thermostat set point, the fan reverts to the pre-set lower speed.

This way the motor frequent speed switches during its operation in the environment with the temperature close to the threshold value are prevented. This control logic enables tracking temperature fluctuations and respond to the temperature change with accuracy up to 2°C. The rate of the speed switching depends exclusively on the air temperature fluctuations.

Speed controller:

This option is available for the models VKM P, VKMz P (fig. 4, 6). It is used for the fan smooth speed control which is set by the speed control knob 9.

VC-VK fan (fig. 7) consists of the casing 1 with the motor and impeller block 4 fixed on the fixing bracket 4 inside. The fixing bracket is attached to the casing with four screws 3. The terminal box 5 is attached to the casing bottom on the intake spigot side to enable connection to power mains and placement of the capacitor.

Mounting sequence for fixing the fan on the wall or to the ceiling:

- drill the holes in the mounting surface to match the fitment holes in the fan basement and fix the fan with screws.

The **fan VC-VN, VCz-VN** (fig. 8, 11) consists of the casing 1 with the motor-impeller block 3 attached to the fixing bracket 2 inside. The casing is attached to the base plate with screws 5. The terminal box 4 is located on top of the casing on intake spigot side to facilitate connection of the fan to power mains and placement of the capacitor.

Mounting sequence for fixing the fan on the wall or to the ceiling:

- drill the holes in the mounting surface to match the fitment holes in the fan basement;
- fix the fan with screws.

The **fan VC-PN** (fig. 9) consists of the casing 1 with the motor-impeller block 5 attached to the fixing bracket 2 inside. The fixing bracket is attached to the casing with four screws 3.

The terminal box 6 is located on top of the casing on intake spigot side to facilitate connection of the fan to power mains and placement of the capacitor.

Mounting sequence for fixing the fan on the wall or to the ceiling:

- drill the holes in the mounting surface to match the fitment holes in the fan basement;
- fix the fan with screws.

The fan **VC-PK** (fig. 10) consists of the casing 1 with the motor-impeller block 3 attached to the fixing bracket 2 inside. The fixing bracket 2 is attached to the casing with four screws 5. The exhaust hole of the fan is covered with a grille.

The terminal box 4 is located on top of the casing on intake spigot side to facilitate connection of the fan to power mains.

Mounting sequence for fixing the fan on the wall or to the ceiling:

- drill the holes in the mounting surface to match the fitment holes in the fan basement;
- fix the fan with screws.

CONNECTION TO POWER MAINS

Cut power supply off before any operations with the fan. The fan must be connected to power mains by a duly qualified electrician. The rated electrical parameters of the fan are shown on the sticker. Any modifications of the internal connections are not allowed and will void the warranty.

The fan is rated for connection to single-phase ac 230 V / 50 Hz power mains.

Connect the fan to power mains by means of insulated, durable and thermal-resistant cords (cables, wires).

Install the automatic circuit breaker at the external electric input 230 V / 50 Hz and integrate it into the fixed wireworks. Install the automatic circuit breaker QF in such a way to provide quick unhampered access to it in case of emergency.

The trip current must be in compliance with the fan current consumption. The recommended rated current:

- 2 A for the fans VKMS 315, VKM 355Q, VCS 315;
- 3.15 A for the fans VKM 400, VKM 450;
- 1 A for all other fans.

The recommended wire cross section is 0.75 mm². The above cross section is for reference only. The applicable cable must be selected in consideration of the maximum wire temperature depending on the wire and insulation type, the maximum current, the lead wire length and its layout type.

Connect the cables to the terminal block incorporated inside the terminal box located on the fan casing in compliance with the fan wiring diagram and the terminal designation.

The terminal designations are shown on the sticker inside the fan casing.

The wiring diagram for the fans VKM 400, VKM 450 is shown in fig. 13. The wiring diagram for the other fans is shown in fig. 12.

The fans with a speed controller and temperature and speed controller (VKM Un, VKMz Un, VKM P, VKMz P) are designed for connection to single-phase ac power mains 230 V / 50 Hz and are equipped with a power cord and a plug (supplied connected to the terminal block).



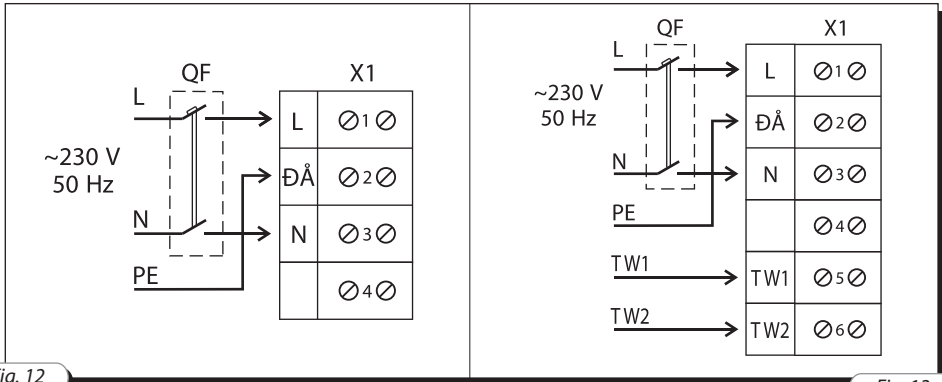

Fig. 12

Fig. 13

The terminals TW1, TW2 are the electrical leads of the normally closed contact of the motor overheating protection. Connect the contact in series to power circuit of the magnetic starter coil KM1 that starts the motor after pressing the button S1. After the motor overheating the contact gets broken and switches the starter coil off to cut power off and stop the motor.

The automatic circuit breaker QF, the magnetic starter KM1, the control knobs S1 and S2 are not included into the delivery set and are installed by the users. The motor connection example with leaded outside thermal protecting contacts are shown in fig. 14.

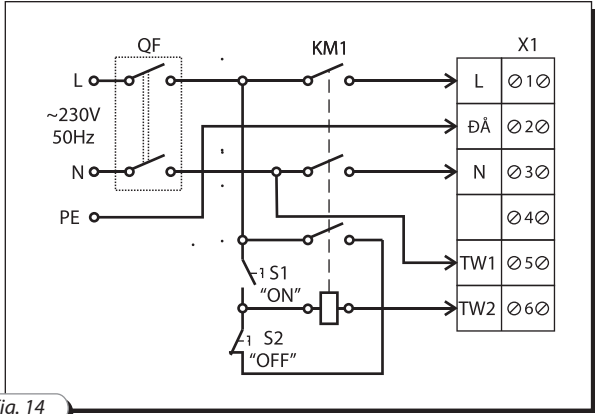

Fig. 14

MAINTENANCE

Disconnect the fan from power mains prior to maintenance and servicing operations. Maintenance means regular cleaning of the fan surfaces from dust and dirt. Use a soft dry brush or a vacuum cleaner to remove dust.

The impeller blades require thorough cleaning once in 6 months. Cleaning procedure:

VKM, VKMz (fig. 4, 6)

remove the screws 3 and take off the cover 2.

VC-VK (fig. 7)

- remove the screws 3 and pull out the motor-impeller block with the fixing bracket 2.

VC-VN, VCz-VN (fig. 8, 11)

- remove the screws 5 and pull out the motor-impeller block with the fixing bracket 2.

VC-PN (fig. 9)

- remove the screws 3 and pull the fixing bracket 2 with the impeller 5 out of the casing.

VC-PK (fig. 10)

- remove the screws 5 and pull the fixing bracket 2 with the impeller 3 out of the casing 1.

Clean the impeller blades with a soft cloth wetted in mild water detergent solution. Avoid liquid dripping on the motor.

STORAGE REQUIREMENTS

Store the fan in the manufacturer's original packing box in a dry ventilated premise at the temperatures from +5°C up to + 40°C and relative humidity less than 80% (at the temperature +20°C).

Acid, alkali vapours and other aggressive substances are not allowed in the storage environment.

MANUFACTURER'S WARRANTY

The fan is manufactured at the factory of "Ventilation systems" Pr JSC (hereinafter referred to as the Manufacturer).

By purchasing this product the customer confirms to have read and agreed to the warranty terms.

The manufacturing company sets forth the warranty period (service life) of the product as 24 months following the sale date via retail network subject to the customer's ensuring compliance with the rules of transportation, storage, mounting and operation of the product. In case of no confirmation of the sales date the warranty period is calculated from the manufacturing date.

All the units and components belonging to the faulty unit and replaced within the warranty period shall be covered by the previous warranty period and general warranty conditions. Thus the warranty period is neither extended nor renewed for the replaced components or the unit.

In case of failure due to faulty equipment during the warranty period the consumer has the right to get it exchanged at the manufacturing facility.

For the product replacement please contact your Seller.

The accessories operated together with the unit, both included and not included into the delivery list as well as other equipment operating jointly with the unit are not covered by the warranty.

The company is not responsible for compatibility of their goods with other producers' goods. The warranty covers the manufacturing defects only.

All the defects and faults resulting from gross mechanical effect during operation process or natural wear-and-tear are not covered by the warranty conditions.

The faults caused by violence of operation, servicing and maintenance guidelines either by Customer or third parties or caused by unauthorized design modifications shall not be covered by warranty.

WARRANTY LIMITATION

The manufacturer is not responsible for any mechanical or physical damages resulting from the manual requirements violence, the unit misuse or gross mechanical effect.

Indirect damages such as re-installation or re-connection of the unit, direct or indirect losses related to the unit replacement shall not be indemnified.

Mounting/dismantling, connection/disconnection and adjustment of the unit shall not be covered by the warranty.

The contractor in charge for mounting, electric mounting and adjustment works shall be responsible for quality and warranty of these works. In any case the indemnity amount shall not exceed the actually paid value for the defective unit price.

ACCEPTANCE CERTIFICATE

VENTS fan _____ has been duly certified as serviceable.
(fill the field)

We hereby declare that the following product complies with the essential protection requirements of Electromagnetic Council Directive 2004/108/EC, 89/336/EEC and Low Voltage Directive 2006/95/EC, 73/23/EEC and CE-marking Directive 93/68/EEC on the approximation of the laws of the Member States relating to electromagnetic compatibility.

Stamp of the acceptance inspector _____ Date of production _____

Sold by
name of the vendor, stamp of the retailer _____

Sale date _____

WARRANTY CARD

