

Sound to Sight Showtime™

Instruction Manual

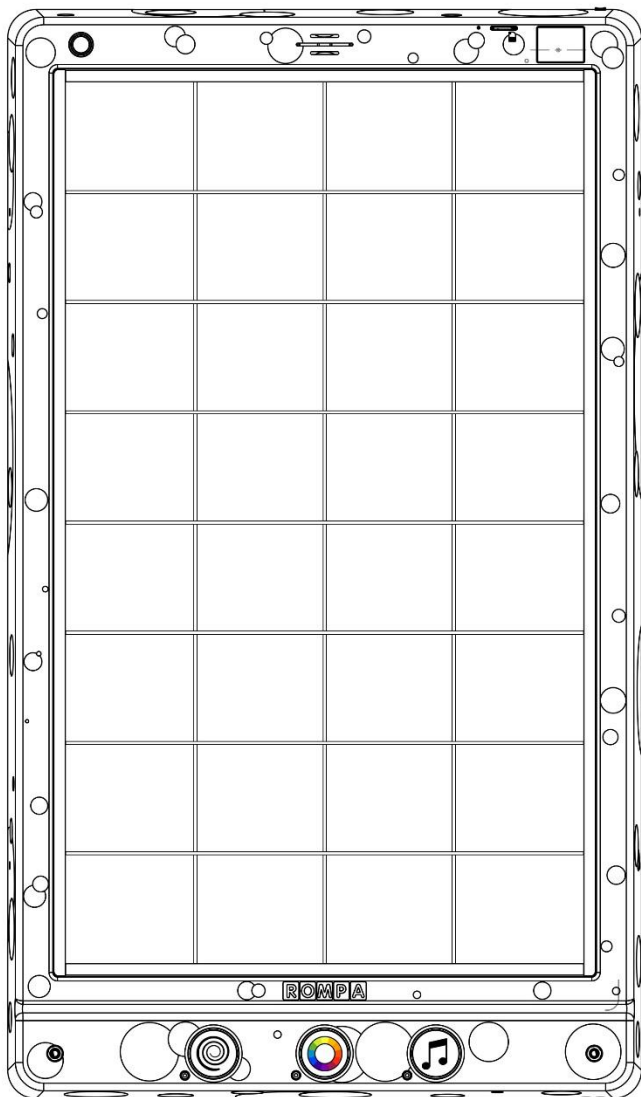

Contents

3	Panel Overview
5	Colour
5	Description
5	Technical Specification
6	Dimensions
7	Contents
7	Compatible Rompa® Products
8	Operation
8	Modes
9	Touch Screen
12	Illuminated Push Buttons
13	External Switches
13	Microphone Input
14	Patterns, Colours & Sound Effects
17	Rompa® Wireless Operation
18	Installation
24	Safety
25	Care and Maintenance
26	Troubleshooting

Panel Overview (Front)

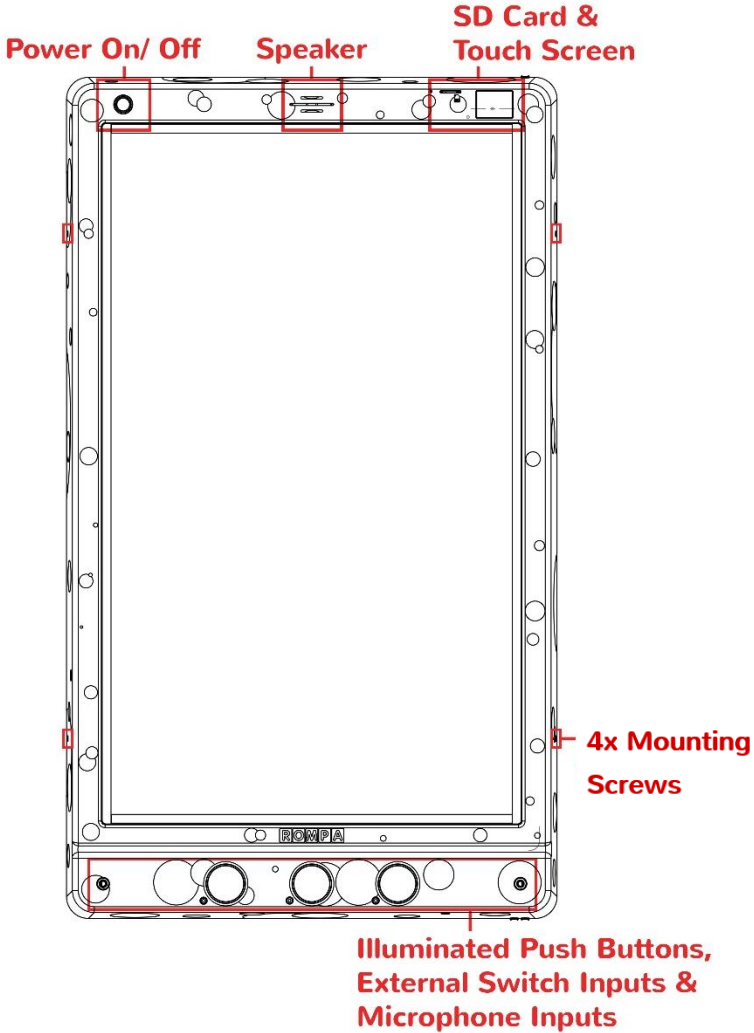

Panel Overview (Back)

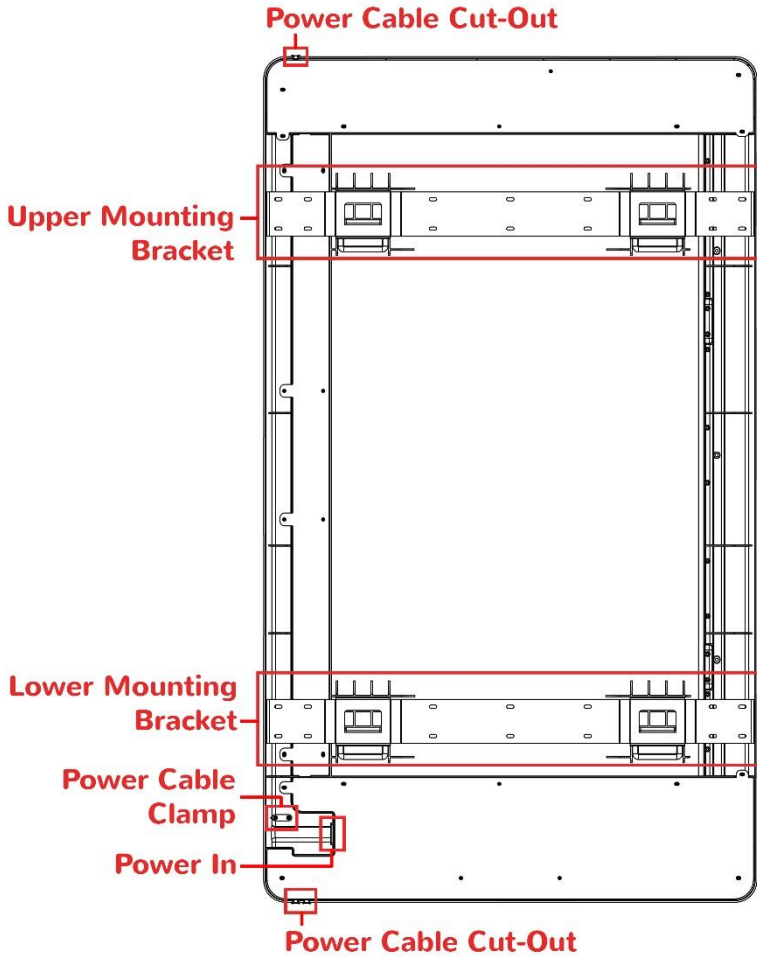

Colour

The Panel is available in 4 colours:

Black, White, Cream and Blue

Description

Sounds are turned into dazzling shows of light, colour and movement. The panel responds to both changes in pitch and volume to create an ever changing sensory experience.

Engaging, interactive and rewarding. Encourages learning, exploration and fosters a feeling of empowerment.

Why not try whistling, humming or clapping?

Technical Specification

Weight:	13kg
Input:	100-240V 50/60Hz
Output:	5V DC 10A
Material:	ABS (Phthalate-Free)

Dimensions

(All dimensions in mm)

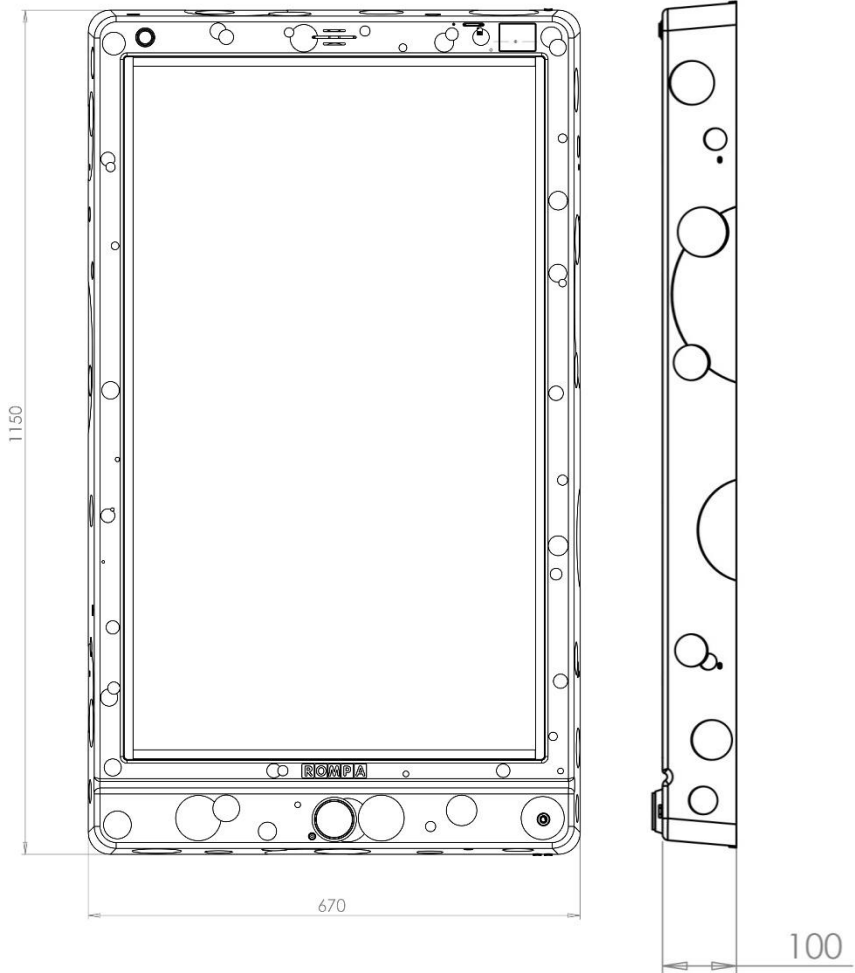

Contents

- 1x Sound to Sight Showtime™
- 2x High Quality Microphone
- 2x Wall Mounting Bracket
- 4x M4 Screws (screwed on sides)
- 1x UK Mains Lead
- 1x US Mains Lead
- 1x EU Mains Lead

Compatible Rompa® Products

- 20848 Sensory Magic®
- 21098 Sensory Magic Portable®
- 19847 Deluxe 8 Colour Wirefree Controller
- 21006 8 Colour Wirefree Switch
- 19939 WiFi Interactive Carpet Switch Set
- 18870 Talking Cube
- 20402 Mini Talking Cube
- 21917 WiFi Microphone
- 22871 Colour Command Centre™
- 21918 WiFi Override Transmitter
- 21728 WiFi App Control Box

Operation

Modes

The mode controls how the panel behaves. The Sound to Sight Showtime™ has 3 modes which can be selected via the touchscreen and an additional mode when one or two microphones are plugged into the ¼"/6.35mm microphone input:

Mode 1: Amplitude and Frequency

The panel reacts to both the amplitude and frequency of a sound. Why not play a song with the built in mp3 and watch the panel dance to the music.

Mode 2: Amplitude

The panel reacts only to the amplitude of a sound (whether the sound is loud or quiet). Great for cause and effect as a clap or loud sound will fill the panel with colour.

Mode 3: Frequency

The panel reacts only to the frequency of a sound (whether the sound is high or low pitched). Why not try and fill certain areas of the panel practicing with different sounds or instruments.

Microphone Mode

This mode cannot be accessed via the touch screen. To access this mode plug a microphone into the ¼"/6.35mm microphone input. The panel will automatically change to microphone mode once a microphone has been detected.

The panel works as normal however sound is detected through the external microphone/s and not from the integrated microphone in the panel.

When there are two microphones plugged in the 'Ladder Pattern' has two 'Ladders' instead of one. Each of the 'Ladders' is controlled by each microphone respectively. This allows users to race or do a call and response game.

Touch Screen

The touch screen is intended for the supervisor of the session, not the primary user of the panel. The touch screen allows you to control in detail how the panel behaves as well as view statistics of panel usage.

Upon booting the panel up it will revert to its default settings:

- Mode 1: Interactive
- Volume: 2
- Touch Screen Brightness: 100%
- Panel Brightness: 100%
- Sound Effects: On
- WiFi: On
- Lock: Off

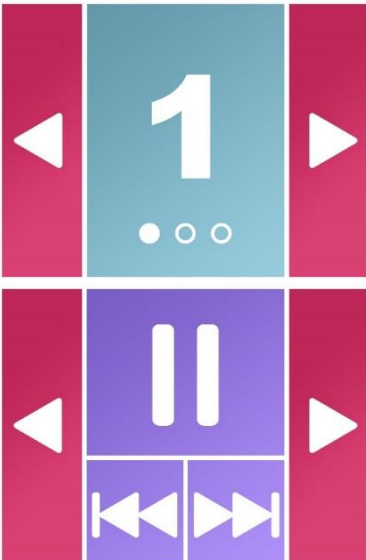

Mode

Press the light blue mode button to cycle through the modes of the panel.

Press the Red forward or back buttons to cycle through the other menu options.

Media*

Press the 'play/ pause' button to play or pause music. Press the 'skip forward' to play the next track or 'skip back' to play the previous.

Press the Red forward or back buttons to cycle through the other menu options.

*This functionality may only be available when an SD card has been inserted.

**Volume**

Pressing the '+' will increase the volume and pressing '-' will reduce the volume.

Press the red forward or back buttons to cycle through the other menu options.

**Sound Effects**

Pressing the light green sound effect button will cycle the sound effects on or off. Sound effect refers to the sounds made when the user activates the illuminated push buttons.

Press the red forward or back buttons to cycle through the other menu options.

**Touch Screen Brightness**

Pressing the yellow screen brightness button will cycle the panel through 6 levels of brightness.

Press the red forward or back buttons to cycle through the other menu options.

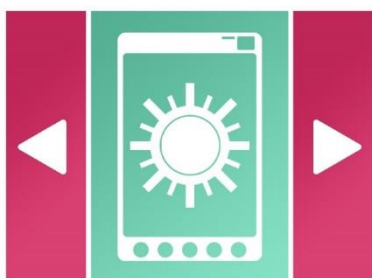
**Panel Brightness**

Pressing the turquoise screen brightness button will cycle the touch screen through 3 levels of brightness.

Press the red forward or back buttons to cycle through the other menu options.



Lock

Pressing the red lock button will lock and unlock the illuminated push buttons. When locked the push buttons will dim and be unresponsive.

Press the red forward or back buttons to cycle through the other menu options.



Wireless

Pressing the purple wireless button will cycle the panel wireless on or off. With wireless turned on the panel will respond to other Rompa® compatible wireless products. With wireless turned off it will ignore Rompa® compatible wireless products.

Press the red forward or back buttons to cycle through the other menu options.



Stats

Pressing the blue stats button will open the stats screen.

From the stats screen you can see in real time the amount of button presses that have been made on the panel and the duration the panel has been used for.

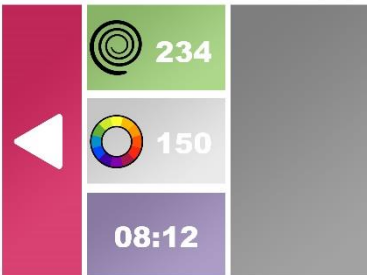

To return to the main menu, press the red back button.

Press the red forward or back buttons to cycle through the other menu options..

Illuminated Push Buttons

The Sound to Sight Showtime™ has 3 illuminated push buttons so the user can control the visual and audio effects the panel produces. When pressed each button will flash and a unique sound effect will be triggered. Sound effects can be turned off via the touch screen. Illuminated buttons can also be locked via the touch screen if required. The brightness of the illuminated buttons is reduced and the buttons are unresponsive when locked.



Pattern

The panel has 8 patterns which can be selected via the 'Pattern' illuminated push button or an external switch plugged into the 'Pattern' input jack.



Colour

The panel has 11 colours which can be selected via the 'Colour' illuminated push button or an external switch plugged into the 'Colour' input jack.



Sound Effect

The panel has 10 unique sound effects which can be played by pressing the 'Sound Effect' illuminated push button or an external switch plugged into the 'Sound effect' input jack. This is an alternate way to interact with the panel for non-vocal users.

External Switches

The panel has 3 external switch inputs each located underneath their associated illuminated push button. To connect the external switch simply plug into the $\frac{1}{4}$ "/6.35mm jack and remove when finished (external switches without a $\frac{1}{4}$ "/6.35mm jack may need an adapter fitting).

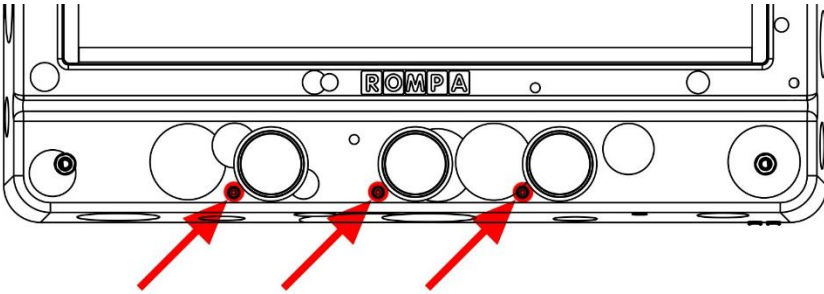

Microphone Input

The panel has 2 microphone inputs. To use a microphone with the panel simply plug a microphone into one of the $\frac{1}{4}$ "/6.35mm jack located in the bottom left and bottom right of the panel. When a microphone is inserted the panel will automatically detect its presence and turn to 'Microphone Mode'. The panel also acts as a karaoke and sounds spoken through the microphone can be heard through the integrated speaker. Simply remove the microphone(s) from the panel when finished and the panel will automatically revert back to its previous mode.

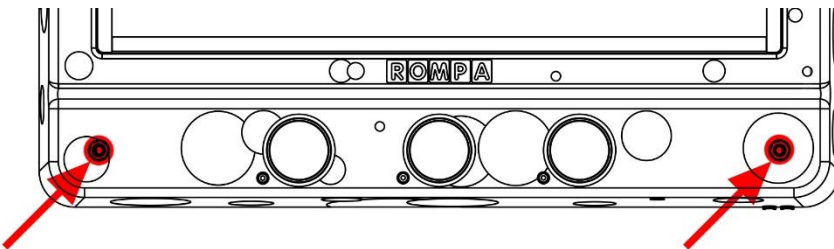

Patterns, Colours and Sound Effects

Patterns

When selecting a pattern a pre-animation is displayed so you know which pattern is selected and what to expect when using it.

- 1 **Equaliser Vertical – Solid Bar**
Vertical bars of light move up and down the panel in response to sounds detected.
 - 2 **Equaliser Horizontal – Single Block**
In each row of the panel a single block of light travels left to right in response to sounds detected.
 - 3 **Equaliser Alternate Sides – Solid Bar**
Like 'Equaliser Vertical – Solid Bar' however the direction of travel is reversed with each column. Half the bars travel up when a sound is detected and the other half travel downwards.
 - 4 **Equaliser Mirrored – Single Block**
A single block of light moves up and down the panel in response to sounds detected in the bottom half of the panel. This pattern is mirrored in the top half of the panel.
 - 5A **Sound Ladder**
A row or rung of the ladder is illuminated each time a sound is detected. When all the rungs are illuminated an auditory and visual reward is given and the pattern resets.
 - 5B **Plugging in two microphones will create two sound ladders each of which can be controlled their associated microphone. This allows for users to race of play call and repeat games.**
- This mode is not frequency dependant and will respond in the same way regardless of mode.*
- 6 **Random Sound Fill**
A random sized block of the screen is illuminated each time a

sound is detected. When the screen is completely illuminated an auditory and visual reward is given. The blocks then fade out and the pattern resets.

This mode is not frequency dependant and will respond in the same way regardless of mode.

7 Scattered Light Show

The panel performs a scattered light show of different colours. The Brightness of the pattern is dictated by the amplitude of the sounds detected by the panel.

8 Random Light Show

The panel performs a light show cycling through 5 pre-set patterns (Inward Spiral, Outward Spiral, Random Fill, Vertical Fill and Horizontal Fill). The Brightness of the pattern is dictated by the amplitude of the sounds detected by the panel.

This mode is not frequency dependant and will respond in the same way regardless of mode.

Colour

- 1 Multi-Coloured (LEDs are multi-coloured)
- 2 All Colours Soft Fade (LEDs transition through colours)
- 3 All Colours Hard Fade (LEDs hard transition through colours)
- 4 Red
- 5 Green
- 6 Blue
- 7 Yellow
- 8 Orange

- 9 Pink
- 10 Purple
- 11 White

Sound Effects

- 1 Cartoon Twisting
- 2 Referee Whistle
- 3 Cartoon Jump
- 4 Power Down
- 5 Knock
- 6 Arpeggio
- 7 Harp
- 8 Organ
- 9 Clapping
- 10 Bubbles

Rompa® Wireless Operation

The Sound to Sight Showtime™ is compatible with a range of Rompa® wireless products (see Compatible Rompa® Products):

8 Colour Wirefree Controller: Simple and Deluxe

Pressing the colour buttons turns the panel to the corresponding colour selected. The panel will remain this colour unless a new colour is selected via the panel or a Rompa® wireless controller or the panel is in a passive mode where it continue cycling through colours and patterns after 60 seconds.

Pressing the central 'function button' acts as pressing the pattern button on the panel. Pressing the function button multiple times allows the user to cycle through all 8 of the panel's patterns.

Other Wireless Products

Selecting a colour changes all the LEDs in array to the corresponding colour selected. The panel will remain this colour unless a new colour is selected via the panel or a Rompa® wireless controller or the panel is in a passive mode where it continue cycling through colours and patterns after 60 seconds.

Installation

Installing Wall Mount Brackets & Panel

Ensure that, after installation, the mains plug and/or power switch for the Panel is easily accessible to facilitate removal of power.

Due to the size of the product it is recommended that two people are required to install the product.

Recommended Tools

- Drill
- Spirit Level
- Pencil
- Tape Measure
- Appropriate Fixings (e.g. Wall plugs, etc)

(All dimensions in mm)

MAX screws in total per bracket: 14

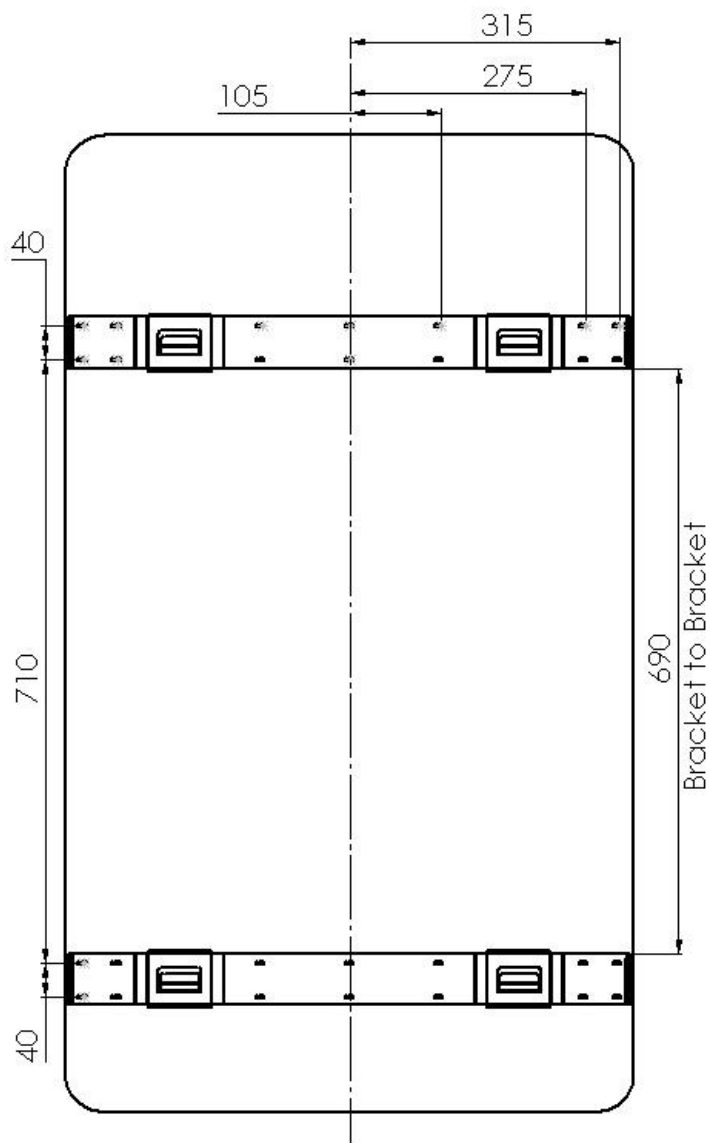

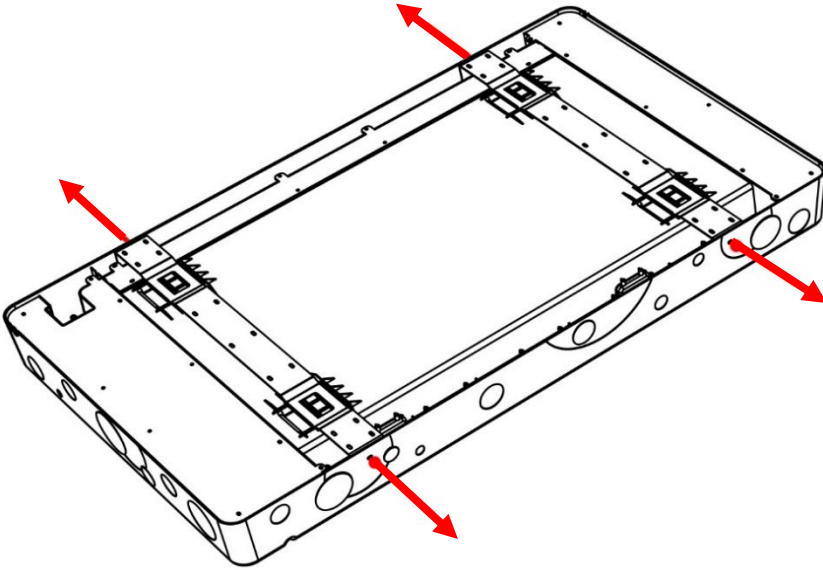

1. Unscrew the 4x M4 screws which secure the 2x brackets to the panels. The brackets are secured to avoid any damage during transit.

Be sure to place the 4x M4 screws in a safe place as they will be required later.

2. Remove the brackets from the panel by sliding the bracket down and then lift them out of panel.

Place the brackets safely to one side as they will be required later.

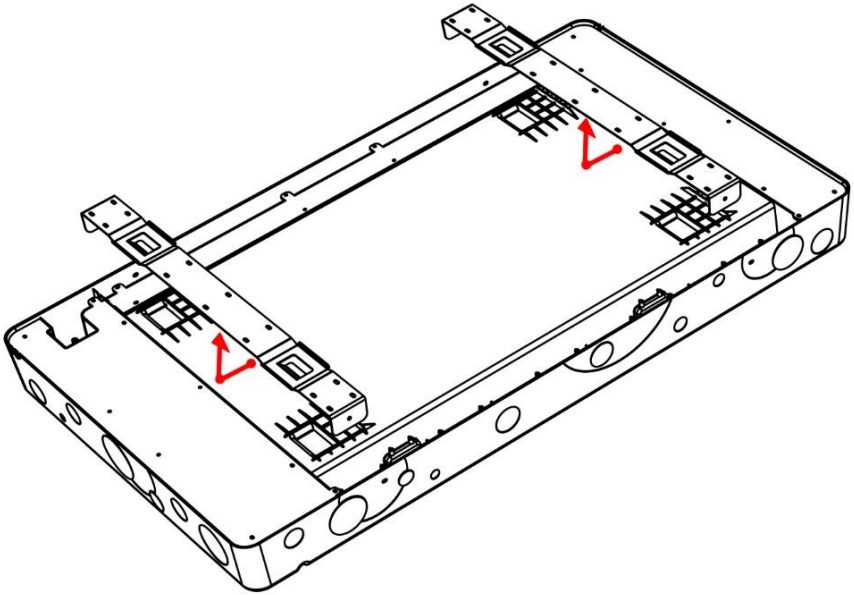

3. Hold the panel where you would like it to be mounted ensuring it is level. Whilst in position mark where the centre of the bracket mounting holes are on the wall. Do this for all 4x bracket mounting holes.

Place the panel safely to the side.

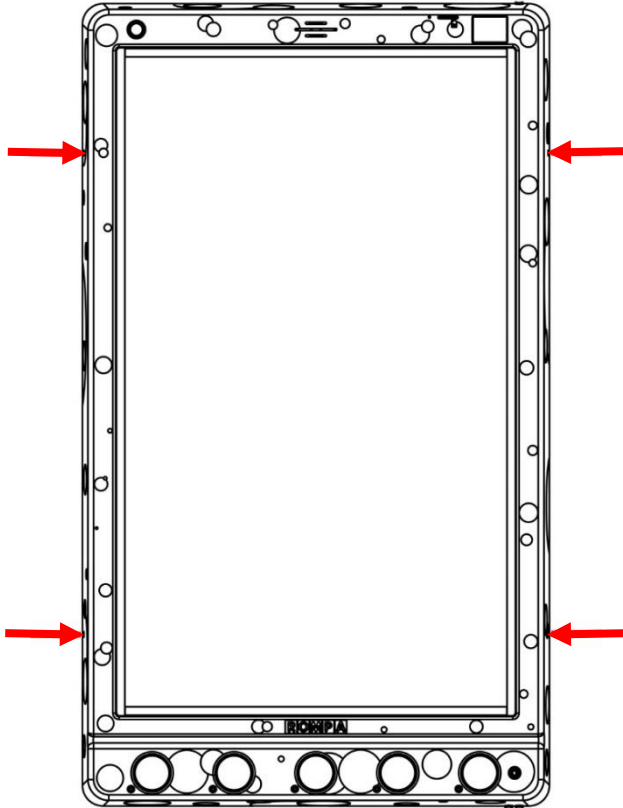

4. Secure both brackets to the wall ensuring the centre of the bracket mounting holes line up with the marks just made to ensure the bracket is level when mounting it to the wall. The top bracket mounting holes should line up with the top 2x marks and the bottom bracket mounting holes should line up with the bottom 2x marks.

*Fasteners are not supplied and must be purchased separately. Please ensure the correct fasteners are used dependant on the construction of wall in question.

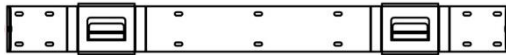
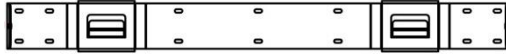

5. Clean the wall and brackets* of any dust and debris which may have been created whilst mounting the brackets.

Place the panel on the brackets. To do this have the panel slightly higher than its final resting position. When you feel the panel has slotted into the bracket gradually lower the panel into position.

Reinstall the 4x M4 screws into the mounting bracket holes.

Safety

Installation

- Panel must be installed indoors in a dry environment. Do not install the panel where it may be subject to excessive heat or moisture as this may damage the product or reduce the product's lifespan.
- Ensure any packaging is disposed of correctly. Plastic bags can be a suffocation risk.
- Ensure the panel is mounted by suitably competent or qualified people. Improper mounting could result in injury. Care should be taken to the type of wall you are mounting the panel to and the appropriate fixings which should be used.
- Consider the height at which you are mounting the panel. The age of the primary user and whether they should be seated or standing should dictate the height at which the panel is mounted.

Operation

- **Panel must always be used under supervision.**
- Do not strike the panel. The panel is built robustly but intentional misuse will shorten the product's lifespan.
- Do not open or attempt to repair the panel yourself as this may cause injury and invalidate the warranty.
- Disconnect any cables when installing or moving the product. Pulling of the cables can cause premature wear or damage to the product and/ or accessories.
- If the product generates abnormal sounds, a burning smell or smoke disconnect immediately and contact Rompa® customer services.
- Do not press and hold the panel push buttons for durations of longer than a minute. Over time this may reduce the life expectancy of the product.

Care and Maintenance

To prolong its product life, please read the following instructions when installing and operating this panel:

- When installing please ensure to keep the layer of protective film on the screen on until the whole panel is fully mounted and is ready for use.
- Ensure no sharp tools or objects are near to the screen.
- Rompa® recommends to use a soft microfibre cloth for cleaning and dusting. It optimises the finish and will prevent scratches onto the screen.
- Slightly dampening the cloth or use of isopropyl alcohol is recommended for more stubborn stains. Ensure the panel does not become wet.
- Particular care should be taken around apertures in the chassis and any electronics (touch screen, power button, illuminated push buttons, external switch jacks and microphone input jack).
- Avoid food or drinks near this panel.
- Do not attempt to physically damage the product including the electronics, screen and buttons.
- Ensure loose wires are out of sight.

At the end of the product's life please dispose of the product ethically:

- Product can be taken to local recycling centre. Visit [RecycleNow.com](https://www.recycle-now.com) to find your local recycling centre.
- Some councils offer a household recycling collection service. Contact your local authority for more details.

Troubleshooting

No Sound	Ensure volume is on and turned up to a sufficient level via the touch screen.
	Turn the panel off and wait 10 seconds. Turn the panel back on. This will reset the panel settings and revert the sound to volume 2 and Sound Effects set to on.
	If troubleshooting does not solve the issue please contact Rompa® Customer Services +44 (0) 1246 211 777
Frozen or Unresponsive	Turn the panel off and wait 10 seconds. Turn the panel back on. This will reset the panel and revert the 1 st mode shown on Touch Screen.
	If troubleshooting does not solve the issue please contact Rompa® Customer Services +44 (0) 1246 211 777
Push Button(s) Unresponsive	Ensure panel buttons are not locked via the touch screen.
	Turn the panel off and wait 10 seconds. Turn the panel back on. This will reset the panel settings and revert the panel buttons to unlock.
	If troubleshooting does not solve the issue please contact Rompa® Customer Services +44 (0) 1246 211 777
External Switch Unresponsive	Ensure the switch inlet is clear of any dust or debris.
	Ensure the switch is fully inserted into the inlet.
	Ensure panel buttons are not locked via the touch screen.
	Turn the panel off and wait 10 seconds. Turn the panel back on. This will reset the panel settings and revert the panel buttons to unlock.
	If troubleshooting does not solve the issue please contact Rompa® Customer Services +44 (0) 1246 211 777
No Power	Ensure the mains is off before checking the power cable is fully inserted into the panel and then turn the mains back on.
	Check the power lead's fuse.
	If troubleshooting does not solve the issue please contact Rompa® Customer Services +44 (0) 1246 211 777

For further copies of this manual, please visit
www.Rompa.com **to access the instruction booklet.**