

# Double Bubble Bonanza™

## Instruction Manual

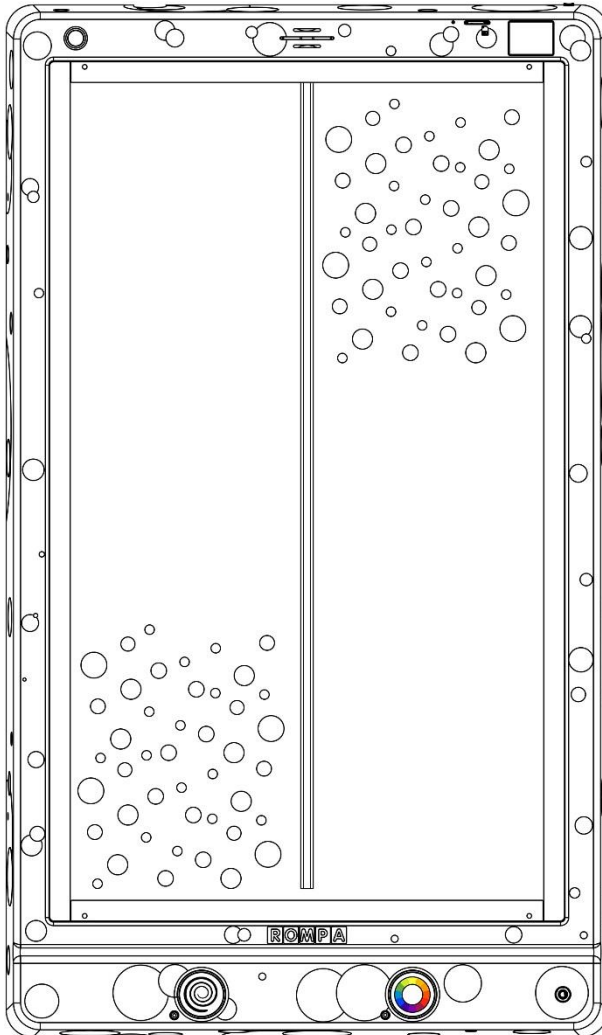

# Contents

3	Panel Overview
4	Colour
4	Description
4	Technical Specification
5	Dimensions
6	Contents
6	Compatible Rompa® Products
7	Operation
7	Modes
9	Touch Screen
13	Illuminated Push Buttons
14	Patterns and Colours
15	External Switches
16	Microphone Input
17	Rompa® Wireless Operation
19	Installation
25	Safety
27	Care and Maintenance
29	Troubleshooting

# Panel Overview

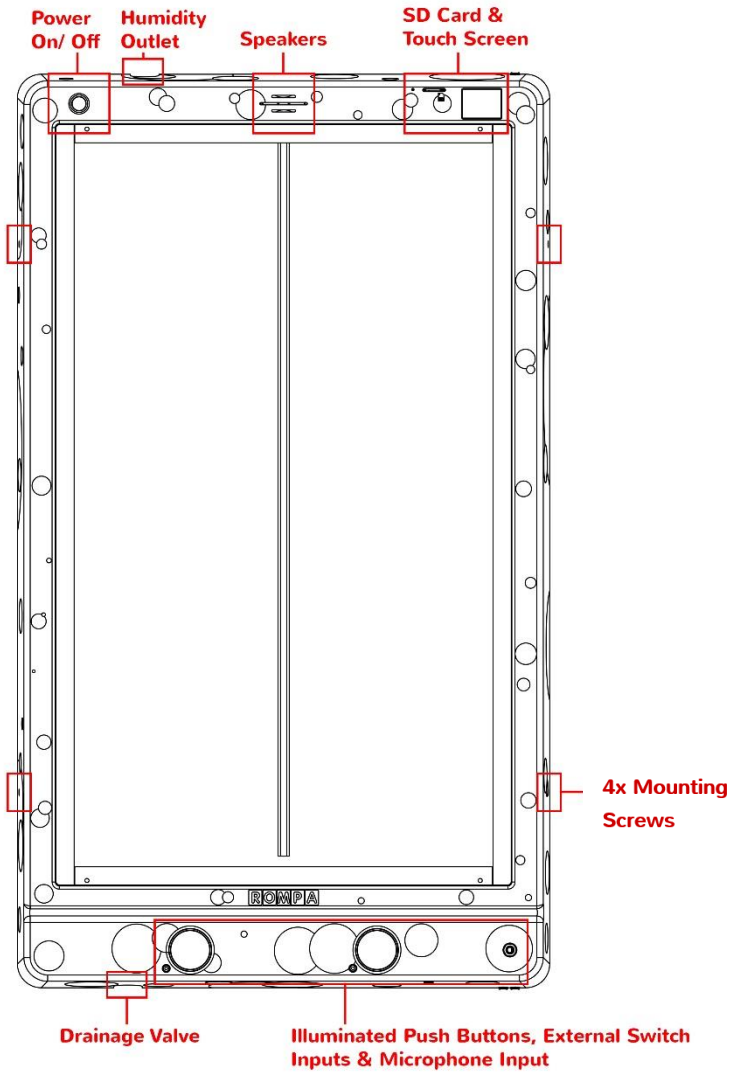

## Colour

The Panel is available in 4 colours: Black, White, Cream and Blue

## Description

Control the bubbles and colours in each of the Double Bubble Bonanza™ chambers. Be amazed as bubbles dissipate in one chamber only to burst into life in the other.

The panel is packed with sound effects and music which makes for a truly exciting multi-sensory experience. With a huge range of effects to choose from! The stunning effects stimulate, empower and engage. Perfect for co-operative play, turn taking and follow-my-lead activities.

## Technical Specification

Weight:	23Kg
Weight tank when is full:	28-33Kg
Material:	ABS (Phthalate-Free)

### UK and Europe

Input: 230-240V  
Output: 12V AC

### US

Input: 110V  
Output: 12V AC

# Dimensions

*(All dimensions in mm)*

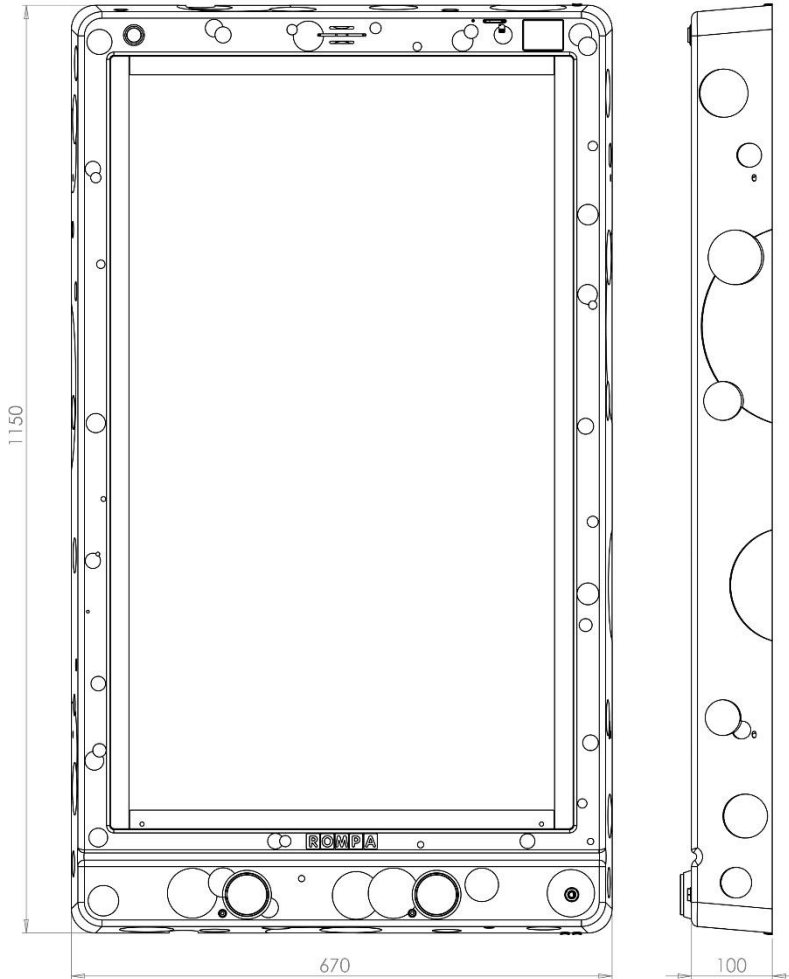

## Contents

1 x Double Bubble Bonanza™

1 x UK/European Power Supply or US Power Supply

### Recommended products

20908 Bubble Tube Filling Pump

## Compatible Rompa® Products

20848 Sensory Magic®

21098 Sensory Magic Portable®

19847 Deluxe 8 Colour Wirefree Controller

21006 8 Colour Wirefree Switch

19939 WiFi Interactive Mat Switch Set

18870 Talking Cube

20402 Mini Talking Cube

21917 WiFi Microphone

22871 Colour Command Centre™

21918 WiFi Override Transmitter

21728 Rompa® WiFi App Control Box

22716 Rompa®WiFi Colour Control Bumpas – set of 8

22867 Wireless Colour Controller Cushioned Wall Mat

# Operation

## Modes

The mode dictates how the panel behaves. The Double Bubble Bonanza™ has 3 modes which can be selected via the touch and an additional mode when one or two microphones are plugged into the ¼"/6.35mm microphone input:

### Mode 1: Interactive

The panel does not change current pattern or colour unless told to do so via the illuminated push buttons.

### Mode 2: Creative

Control the bubbles in each chamber via the two push buttons. Pressing the button on the left (Pattern) activates bubbles in the left chamber of the panel. Pressing the button on the right (Colour) activates bubbles in the right chamber of the panel. Bubbles are triggered when the button is pressed so a short burst of bubbles can be created by tapping the button(s) or a longer stream can be created by holding the button(s).

### Mode 3: Music and Sound Effects

Music and sound effects are paired with each pattern for a more stimulating multisensory experience. The panel works as Mode 1: Interactive.

## Microphone Mode

This mode cannot be accessed via the touch screen. To access this mode plug a microphone into the ¼"/6.35mm microphone input. The panel will automatically change to microphone mode once a microphone has been detected. The mode and brightness of the panel cannot be adjusted via the touchscreen whilst a microphone is plugged in.

When the microphone detects a sound a burst of bubbles is produced.



## Touch Screen

The touch screen is intended for the supervisor of the session, not the primary user of the panel. The touch screen allows you to control in detail how the panel behaves as well as view statistics of panel usage.

Upon booting the panel up it will revert to its default settings:

Mode 1: Interactive

Volume: 2

Touch Screen Brightness: 100%

Panel Brightness: 100%

Sound Effects: On

WiFi: On

Lock: Off



### Mode

Press the light blue mode button to cycle through the modes of the panel.

Press the Red forward or back buttons to cycle through the other menu options.

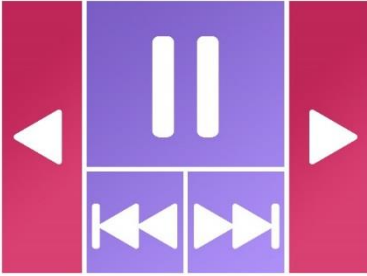

### Media\*

Press the 'play/ pause' button to play or pause music. Press the 'skip forward' to play the next track or 'skip back' to play the previous.

Press the red forward or back buttons to cycle through the other menu options.

\*This functionality may only be available when an SD card has been inserted.

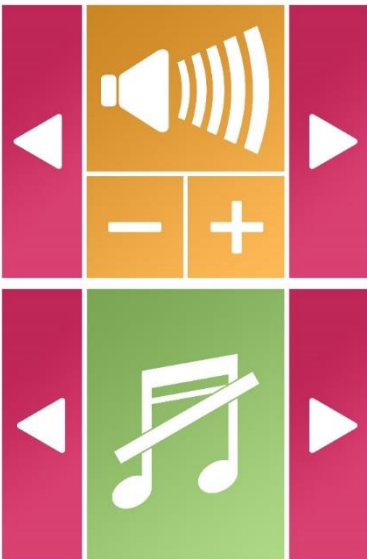

### Volume

Pressing the '+' will increase the volume and pressing '-' will reduce the volume.

Press the red forward or back buttons to cycle through the other menu options.

### Sound Effects

Pressing the light green sound effect button will cycle the sound effects on or off. Sound effect refers to the sounds made when the user activates the illuminated push buttons.

Press the red forward or back buttons to cycle through the other menu options.

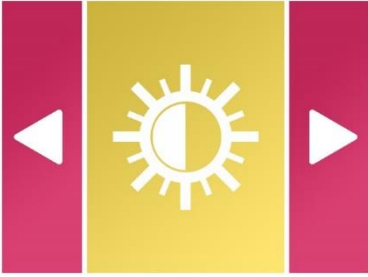

### Touch Screen Brightness

Pressing the yellow screen brightness button will cycle the panel through 6 levels of brightness to 100%.

Press the red forward or back buttons to cycle through the other menu options.

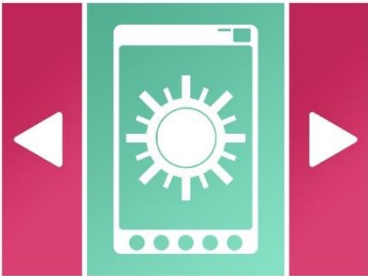

### Panel Brightness

Pressing the turquoise screen brightness button will cycle the touch screen through 3 levels of brightness to 100%.

Press the red forward or back buttons to cycle through the other menu options.



### Lock

Pressing the red lock button will lock and unlock the illuminated push buttons. When locked the push buttons will dim and be unresponsive.

Press the red forward or back buttons to cycle through the other menu options.



### Wireless

Pressing the purple wireless button will cycle the panel wireless on or off. With wireless turned on the panel will respond to other Rompa® compatible wireless products. With wireless turned off it will ignore Rompa® compatible wireless products (Page 6).

Press the red forward or back buttons to cycle through the other menu options.



### Stats

Pressing the blue stats button will open the stats screen.

From the stats screen you can see in real time the amount of button presses that have been made on the panel and the duration the panel has been used for.

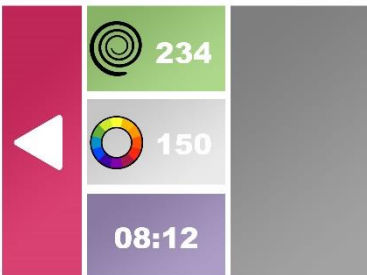

To return to the main menu, press the red back button.

Press the red forward or back buttons to cycle through the other menu options.

# Illuminated Push Buttons

The Double Bubble Bonanza™ has 2 illuminated push buttons so the user can control the visual and audio effects the panel produces. When pressed, each button will flash and a unique sound effect will be triggered. Sound effects can be turned off via the touch screen (Page 9). Illuminated buttons can also be locked via the touch screen if required. The brightness of the illuminated buttons is reduced and the buttons are unresponsive when locked (Page 10, Lock setting). When using the Wireless setting (Page 10) it would benefit in keeping the same illuminating setting on while using other Rompa® products.



## Pattern

The panel has 3 patterns which can be selected via the 'Pattern' illuminated push button or an external switch plugged into the 'Pattern' ¼"/6.35mm input jack.



## Colour

The panel has 14 colours which can be selected via the 'Colour' illuminated push button or an external switch plugged into the 'Colour' ¼"/6.35mm input jack.

# Patterns and Colours

## Patterns

- 1 No Pattern  
All LEDs are illuminated with no change.
- 2 Bubble Burst  
A burst of bubbles will flow up both channels followed by a break. The pattern then repeats.
- 3 Alternate Bubble Burst  
A burst of bubbles with the 1st chamber on, the other chamber turns bubbles off simultaneously. Then it turns opposite with 1<sup>st</sup> chamber turn off and a burst of bubbles on the other chamber. This cycle is then repeats.

## Colour

- 1 Multi-Coloured (LEDs are multi-coloured)
- 2 All Colours Soft Fade (LEDs transition through colours)
- 3 All Colours Hard Fade (LEDs hard transition through colours)
- 4 Red
- 5 Green
- 6 Blue
- 7 Yellow

- 8 Orange
- 9 Pink
- 10 Purple
- 11 White
- 12 Individual Chambers Soft Fade (LEDs transition through colours – each chamber is a different colour)
- 13 Individual Chambers Hard Fade (LEDs hard transition through colours – each chamber is a different colour)
- 14 Colour Chase (LEDs change colour in time with the rising bubbles – Bubble Burst and Alternating patterns only)

## External Switches

The panel has 2 external switch inputs each located next to their associated illuminated push button. To connect the external switch simply plug into the ¼"/6.35mm jack and remove when finished (external switches without a ¼"/6.35mm may need an adapter fitting).

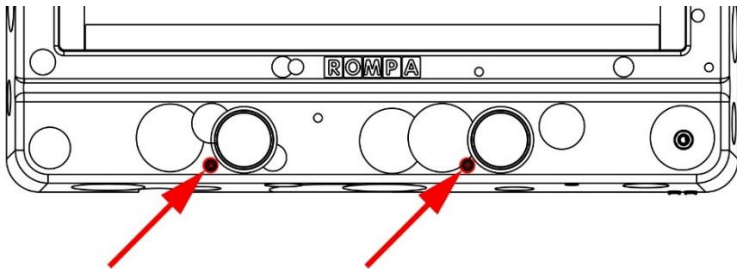

## Microphone Input

The panel has 1 microphone input. To use a microphone with the panel simply plug a microphone into the ¼"/6.35mm jack located in the bottom right of the panel. When the microphone is inserted the panel will automatically detect its presence and turn to 'Microphone Mode'. The panel also acts as a karaoke and sounds spoken through the microphone can be heard through the integrated speaker. When the microphone is removed from the panel, the panel will automatically revert back to its previous mode.

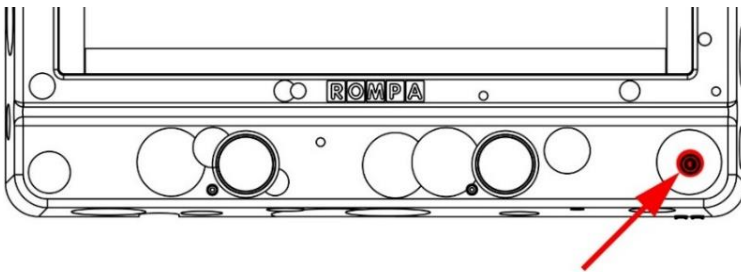



# Rompa® Wireless Operation

The Double Bubble Bonanza™ is compatible with a range of Rompa® wireless products (see page 6):

## 8 Colour Wirefree Controller: Simple and Deluxe

Pressing the colour buttons turns both chambers to the corresponding colour selected. The panel will remain this colour unless a new colour is selected via the panel, a Rompa® wireless controller or the panel is in a passive mode where it continues cycling through colours and patterns after 60 seconds.

The Function Button acts differently in each of the panel's 3 modes.

### *Mode 1:*

During Mode 1 the function button acts as a Play/Pause button enabling the user to freeze the pattern in its current state.

### *Mode 2:*

During Mode 2 pressing the function button triggers the panel to release a short burst of bubbles in each chamber.

### *Mode 3:*

This is an automated musical function where the bubbles are automatically pumped by sequence of musical themes. The user can pause the pump and lighting while still playing the music tunes.

## Other Wireless Products

Selecting a colour changes all the LEDs in array to the corresponding colour selected. The panel will remain this colour unless a new colour is selected via the panel, a Rompa® wireless controller or the panel is in a passive mode where it continue cycling through colours and patterns after 60 seconds.

# Installation

## Installing Wall Bracket, Tank & Panel

**Due to the size and weight of the product it is highly recommended that it is installed by two people.**

**Ensure that, after installation, the mains plug and/or power switch for the Panel is easily accessible to facilitate removal of power.**

Ensure that at least one of the two people mounting the panel is deemed competent as. Improper mounting could result in injury and any damage caused would invalidate the warranty.

Due to the weight of the product it must only be installed onto walls of appropriate construction and with the appropriate fixings. This product is not suitable for fitting onto the Rompa® Panel Porter (22879).

### Recommended Tools

- Drill
- Spirit Level
- Pencil
- Tape Measure
- Appropriate Fixings (e.g. Wall plugs, etc.)

(All dimensions in mm)

MAX screws in total per bracket: 14

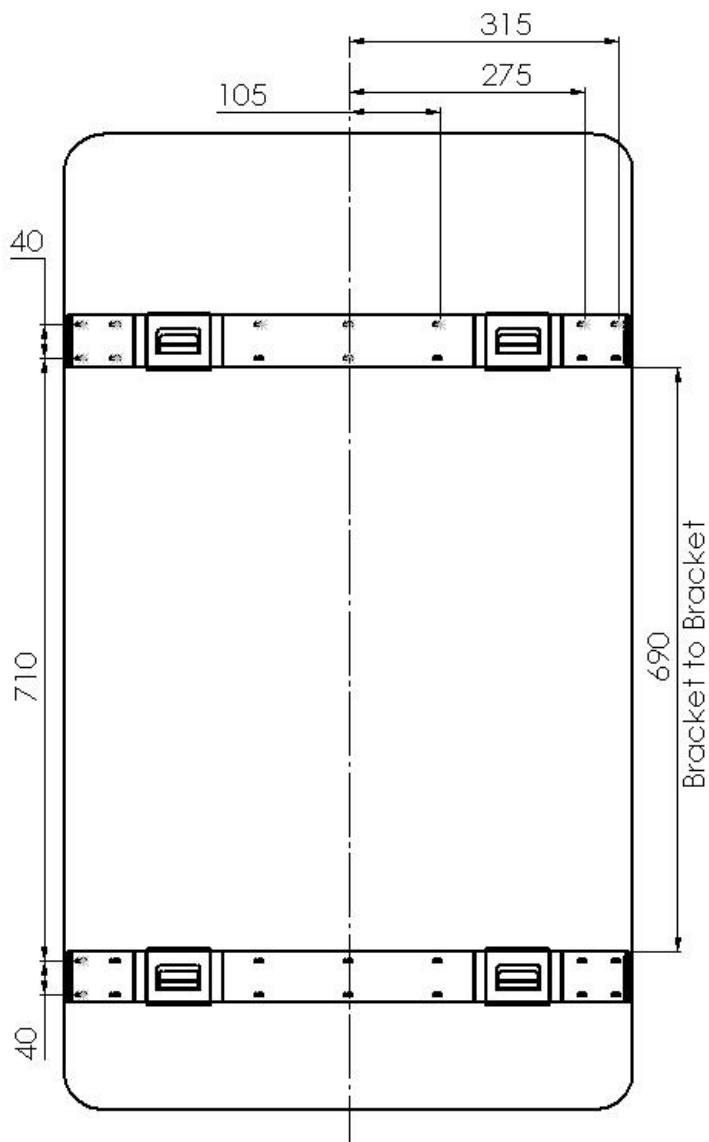

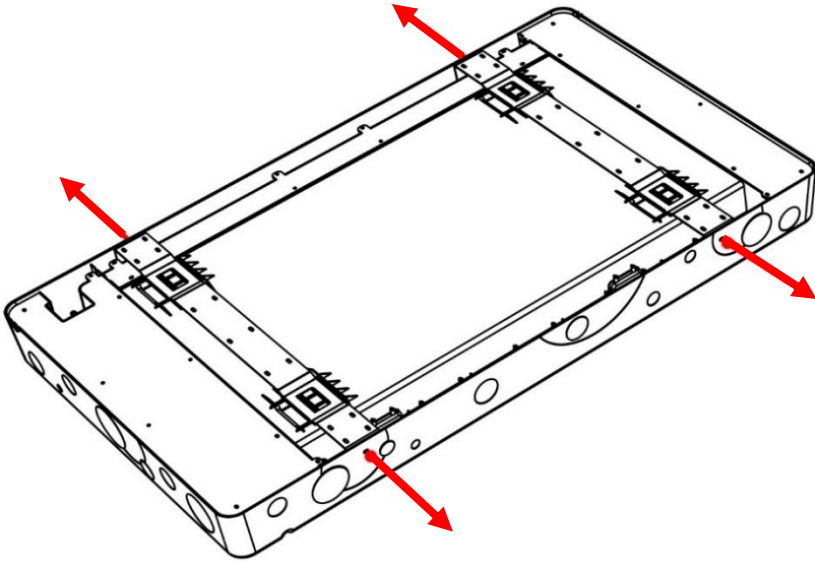

1. Unscrew the 4x M4 screws which secure the 2x brackets to the panels. The brackets are secured to avoid any damage during transit.

Be sure to place the 4x M4 screws in a safe place as they will be required later.

2. Remove the brackets from the panel by sliding the bracket down and then lift them out of panel.

Place the brackets safely to one side as they will be required later.

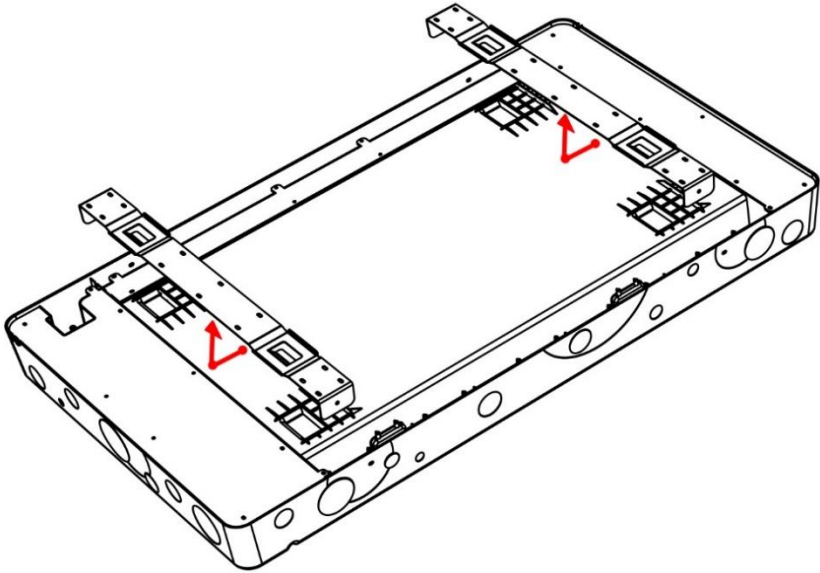

3. Hold the panel where you would like it to be mounted ensuring it is level. Whilst in position mark where the centre of the bracket mounting holes are on the wall. Do this for all 4x bracket mounting holes.

Place the panel safely to the side.

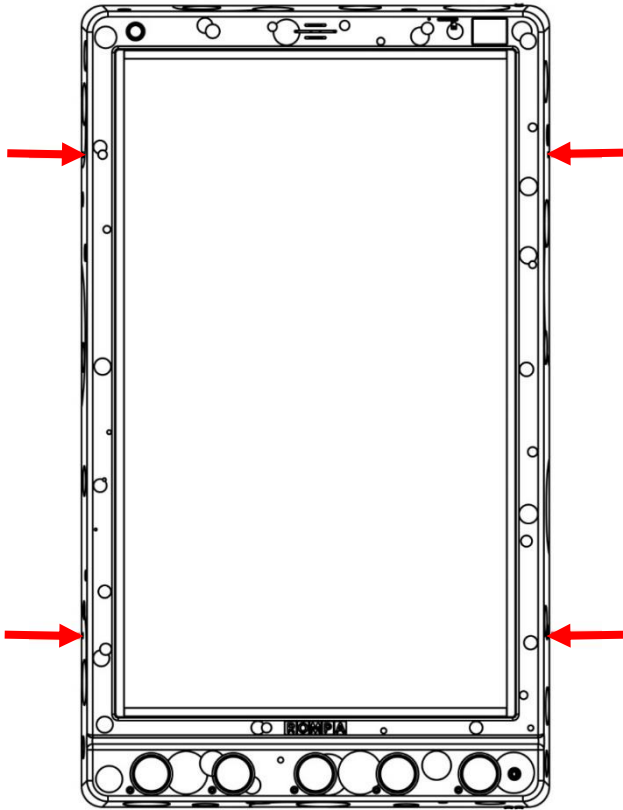

4. Secure both brackets to the wall\* ensuring the centre of the bracket mounting holes line up with the marks just made to ensure the bracket is level when mounting it to the wall. The top bracket mounting holes should line up with the top 2x marks and the bottom bracket mounting holes should line up with the bottom 2x marks.

\*Fasteners are not supplied and must be purchased separately.  
Please ensure the correct fasteners are used dependant on the construction of wall in question.

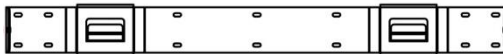
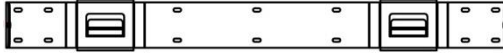

5. Clean the wall and brackets of any dust and debris which may have been created whilst mounting the brackets.

Place the panel on the brackets. To do this have the panel slightly higher than its final resting position. When you feel the panel has slotted into the bracket gradually lower the panel into position.

Reinstall the 4x M4 screws into the mounting bracket holes.



# Safety

## Installation

- Panel must be installed indoors. Do not install the panel where it may be subject to excessive heat or moisture as this may damage the product or reduce the product's lifespan.
- Do not place this with direct sunlight, this will promote algae growth.
- Ensure any packaging is disposed of correctly. Plastic bags can be a suffocation risk.
- Ensure the panel is mounted by suitably competent or qualified people. Improper mounting could result in injury. Care should be taken to the type of wall you are mounting the panel to and the appropriate fixings which should be used.
- Consider the height at which you are mounting the panel. The age of the primary user and whether they should be seated or standing should dictate the height the panel is mounted.

## Operation

- **Panel must always be used under supervision.**
- Do not strike the panel. The panel is built robustly but intentional misuse will shorten the product's lifespan.

- Do not open or attempt to repair the panel yourself as this may cause injury and invalidate the warranty.
- Disconnect any cables when installing or moving the product. Pulling of the cables can cause premature wear or damage to the product and/ or accessories.
- If the product generates abnormal sounds, burning smell or smoke disconnect immediately and contact Rompa® customer services.
- Do not press and hold the panel push buttons for durations of longer than a minute. Over time this may reduce the life expectancy of the product.

## Care and Maintenance

To prolong its product life, please read the following instructions when installing and operating this panel:

- When installing please ensure to keep the layer of protective film on the screen until the whole panel is fully mounted and is ready for use.
- Ensure no sharp tools or objects are near to the screen.
- Rompa® recommends to use a soft microfibre cloth for cleaning and dusting. It optimises the finish and will prevent scratches onto the screen.
- Slightly dampening the cloth is recommended for more stubborn stains. Ensure the panel does not become wet. Wipe the exterior of the panel with a slightly damp cloth. Never use solvent-based cleaning products, methylated spirits, alcohol wipes or liquid detergents to clean this product.
- Particular care should be taken around apertures in the chassis and any electronics (touch screen, power button, illuminated push buttons, external switch jacks and microphone input jack).
- Avoid food or drinks near this panel.
- Do not attempt to physically damage the product including the electronics, screen and buttons.
- Ensure loose wires are out of sight.

- To fill this product with water you require a Rapid Water Change Pump (20601).
- To change the water simply plug the plastic tube that comes in the box into the bottom left and release the valve. This will immediately drain the panel so place a bucket underneath the spout.
- To fill the tank we recommend you power the panel to get the air flow from the pumps, this will account for the water displacement from maximum air flow. After you can drop the Rapid Water Change Pump (20601) into a bucket full with water. Once the water level reaches close to the top turn off and simultaneously remove the connection to the panel, if you do not remove the pump you will have water coming out of the bottom right of the panel. We recommend that the water is changed every 6 weeks.
- Please do **NOT** block the bottom right of the panel as the air is released out of that valve.

At the end of the product's life please dispose of the product ethically:

- Product can be taken to local recycling centre. Visit [RecycleNow.com](https://www.recycle-now.com) to find your local recycling centre.
- Some councils offer a household recycling collection service. Contact your local authority for more details.

# Troubleshooting

No Sound	Ensure volume is on and turned up to a sufficient level via the touch screen.
	Turn the panel off and wait 10 seconds. Turn the panel back on. This will reset the panel settings and revert the sound to volume 2 and Sound Effects set to on.
	If troubleshooting does not solve the issue please contact Rompa® Customer Services +44 (0) 1246 211 777
Frozen or Unresponsive	Turn the panel off and wait 10 seconds. Turn the panel back on. This will reset the panel and revert the 1 <sup>st</sup> mode shown on Touch Screen.
	If troubleshooting does not solve the issue please contact Rompa® Customer Services +44 (0) 1246 211 777
Push Button(s) Unresponsive	Ensure panel buttons are not locked via the touch screen.
	Turn the panel off and wait 10 seconds. Turn the panel back on. This will reset the panel settings and revert the panel buttons to unlock.
	If troubleshooting does not solve the issue please contact Rompa® Customer Services +44 (0) 1246 211 777
External Switch Unresponsive	Ensure the switch inlet is clear of any dust or debris.
	Ensure the switch is fully inserted into the inlet.
	Ensure panel buttons are not locked via the touch screen.
	Turn the panel off and wait 10 seconds. Turn the panel back on. This will reset the panel settings and revert the panel buttons to unlock.
	If troubleshooting does not solve the issue please contact Rompa® Customer Services +44 (0) 1246 211 777

No Power	Ensure the mains is off before checking the power cable is fully inserted into the panel and then turn the mains back on.
	Check the power lead's fuse.
	If troubleshooting does not solve the issue please contact Rompa® Customer Services +44 (0) 1246 211 777

**For further copies of this manual, please visit [www.Rompa.com](http://www.Rompa.com) to access the instruction booklet.**