

spex

Lateral Trunk Supports
Installation & User Manual

IMPORTANT CONSUMER INFORMATION NOTICE:

This manual contains important instructions that must be passed on to the user of this product. Please do not remove this user manual before delivery to the end user.

SUPPLIER: This manual must be given to the user of this product.

USER/CAREGIVER: Before using this product, read entire manual and save for future reference. Transit Safety section **MUST** be read before Lateral Trunk Support is used in a vehicle.

MD: This product is a Medical Device.

User Name / Nom de l'utilisateur :

Serial Number / Numéro de série :

Contents

Introduction	2
Intended Use	3
Contraindications	3
Compatibility	3
Safety Instructions	4
Environment	5
Maintenance & Cleaning	5
Lateral Support Contents	6
Mounting the Lateral to the Back Support shell	7
Width/height adjustment	7
Mounting to Canes	7
Added Depth Options	8
Angle adjustment	8
Depth adjustment	9
Axial adjustments (if fitted)	9
Releasing the swing-away mechanism	9
Releasing the Quick-Release mechanism (if fitted)	10
Biangular adjustments (if fitted)	10
Re-issuing to another user	11
Disposal & Recycling	11
Transit Safety – Assembly, Use, Maintenance & Limitations	12
Transit Safety – Correct Positioning of Belt Restraints	13
Warranty	17

Introduction

Spex recommends that a clinician such as an Occupational or Physiotherapist who is skilled in wheelchair seating and positioning be consulted to determine if the Spex Lateral Trunk Support is appropriate for the user.

Intended Use

Spex Seating is intended for users (disabled and/or discomforted) that require specific postural and positioning support to provide comfort for body function in a sitting posture on wheelchairs for daily activities and for transportation in vehicles. It is designed with ergonomic adjustments to provide improved personal body-posture conditions and/or to help prevent/reduce physical problems associated with sedentary work or activities.

Contraindications

- 1.** Use of Spex Wheelchair seating products may affect the center of gravity causing the Wheelchair to tip, potentially causing injury. Always judge the need for anti-tippers or amputee axle adapter brackets to be added to the Wheelchair to increase stability.
- 2.** Check regularly for skin redness and that pressure spots are not developing. If your skin develops redness, stop using the product and consult your doctor or therapist.

Compatibility

- Spex Lateral Supports have been designed to be compatible with most wheelchairs.
- Spex Lateral Supports are designed to be used with all Back Supports from the Spex range.
- Spex Laterals and mechanisms are tested and certified for the Spex brand and may not be appropriate for installation to other brands of wheelchair Back Supports.
- Spex Laterals and mechanisms are not appropriate for installation to other products or used in a manner other than Back Supports.

Safety Instructions

To avoid injury, read, understand and follow all instructions and warnings in this manual before installing and using the Spex Lateral Trunk Support. There are hazards associated with the use of wheelchairs and adaptive equipment. If you misuse your wheelchair or your Lateral Trunk Support you can be seriously injured. If your Lateral Trunk Support ceases to function as intended, please consult your authorized Spex seating supplier immediately before continuing to use. Any serious incident that has occurred in relation to this product should be reported to Spex Ltd.

The foam and fabric meets the flammability requirements of California Technical Bulletin 117. In rare cases the fabrics used in this product may cause a skin irritation for people with sensitive skin. If you experience any reddening or itching of the skin consult with your health care professional.

Disclaimer: Spex takes no responsibility as to the therapeutic effectiveness of our products. Our claims relate to the ability of the products to provide safe and reliable positioning and seating on the equipment onto which they are installed.



WARNING

- 1. Lateral brackets shipped out disassembled and with brackets attached loosely. It is the installer's responsibility to ensure all hardware is installed correctly and tightened before using the wheelchair.**
- 2. Installation and adjustment of your Laterals should be performed only by an authorized dealer or qualified therapist.**
- 3. Laterals must not be modified or changed as this voids warranty.**
- 4. Only use genuine Spex accessories, components and hardware.**
- 5. Never lift the wheelchair by the Laterals.**
- 6. Never use the Laterals if any hardware is missing, malfunctioning, or broken. Seek qualified assistance with any repairs, replacements or adjustments.**
- 7. A poorly fitted Lateral can aggravate posture problems and the overall safety of the user.**
- 8. The user must not put excessive force against the Lateral.**
- 9. When swinging away the Lateral, ensure the user is supported by a caregiver prior to avoid the user falling from the wheelchair.**
- 10. Be aware of the pinch points of the swing-away pivot points. Ensure all body parts are kept clear during these movements and adjustments.**
- 11. The Lateral locking mechanism must be correctly locking at all times. If it stops locking do not use the equipment.**
- 12. Spex Lateral Supports must be used in conjunction with a stabilized pelvis with hip belt fitted.**
- 13. If the user has significant or forceful leaning to one side, a complete postural evaluation must be undertaken to ascertain the correct wheelchair seating set-up prior to installing Lateral Supports.**
- 14. Do not use Spex Lateral Supports or mechanisms for purposes that they are not designed for.**
- 15. Care must be taken when undertaking a user transfer from the seating system. The user may fall from the wheelchair or injure themselves when supports are removed.**
- 16. Never use the Lateral Support without its cover. Care should be exercised near open flame or burning cigarettes. Using the Lateral Support without its cover increases the risk of flammability and skin damage.**

Environment

Moisture: Keep your Lateral Support dry at all times, as contact with water or excess moisture could cause corrosion, degradation to the functionality of your Lateral Support, or potential failure. If your Lateral Support becomes damp or wet, thoroughly wipe with a dry cloth as soon as possible. Do not use your Lateral Support in a showering or pool facility.

Temperature: Your Lateral Support may not function as intended when used at extreme temperatures. Keep the Lateral Support away from sources of extreme heat or extreme cold to avoid burns from the metal components.

Dirt: Small particles such as dust, dirt and sand may restrict optimum functionality. Regularly check your Lateral Support to ensure no build-up occurs around openings and moving parts.

Maintenance & Cleaning

Check that the hardware is working correctly, if not you must replace immediately. Spex recommends that all fasteners be checked for wear, such as loose bolts or broken components, every 6 months. Loose fasteners should be retightened according to the installation instructions. Contact your authorized Spex Seating supplier immediately to replace any broken components. Do not continue to use the system after identifying loose or broken components. For any questions regarding cleaning procedures, contact your authorized Spex Seating dealer. The expected lifetime of the Lateral Support is 5 years.

Spex recommends using AHP (Accelerated Hydrogen Peroxide) disinfectant wipes. The disinfection product must be used as per the manufacturer instructions. Spex takes no responsibility for the effectiveness of the disinfecting process.

Cleaning the hardware

Hardware may be wiped clean with mild detergent and water. Rinse with clean water. Dry thoroughly after rinsing.

Cleaning the cover

Machine wash in warm water 40° C / 104° F. Drip or tumble dry on low heat. Do not iron, bleach or dry clean. If chemical cleaners are used, covers must be rinsed thoroughly with water to remove all chemical residue and left to dry completely before reuse.

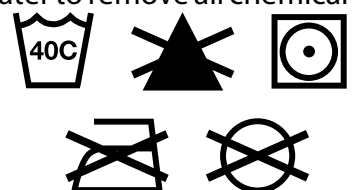

Lateral Support Contents

Your Lateral Support contains the following:

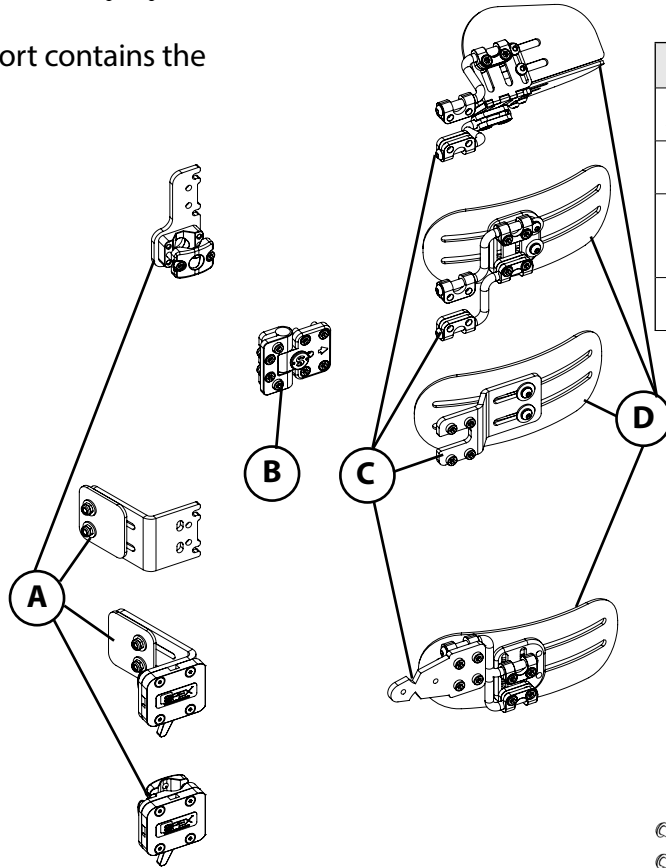

	Description	Quantity
A	Fixing Plate	1
B	Flip Away Hinge	1
C	Support Adjustment Bracketry	1
D	Lateral Support Pad	1

There are multiple options for the above parts examples of which are shown on the right. Your lateral support may include an extension plate, as highlighted.

Note: Quick-Release laterals may be provided with extra Axial bars for extra depth, see page 8 for further detail.

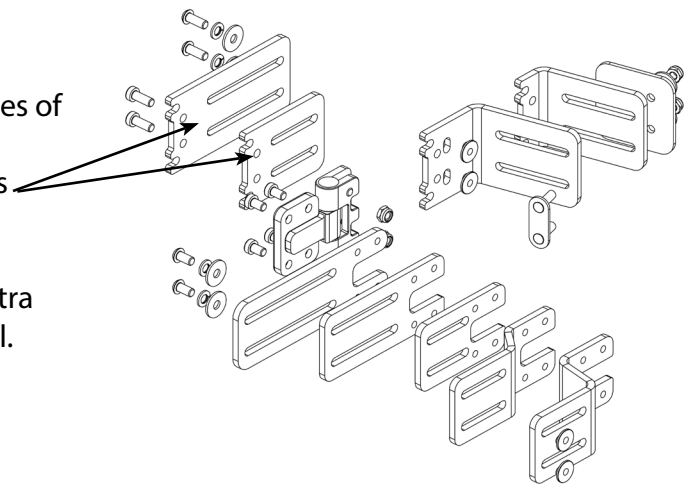

Paediatric laterals contain the same, but will look like the following:

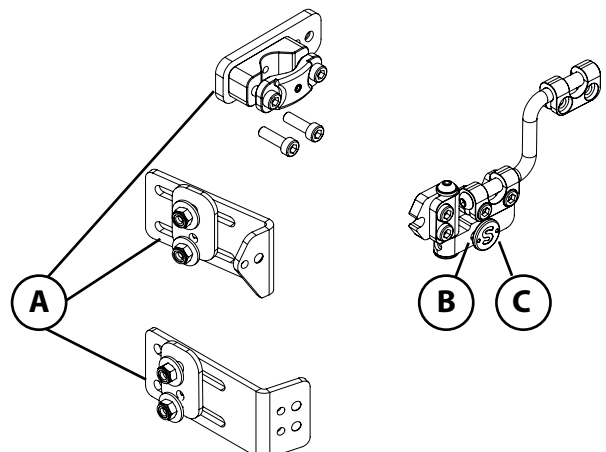

Mounting the Lateral to the Back Support

Tools Required: 4 mm, 5 mm Hex Key, 10 mm Ring Wrench

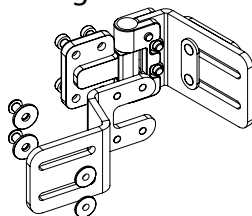
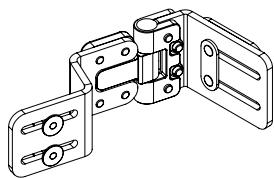

1. Place the Lateral bracket with the rubber pad against the shell as shown.



WARNING

The rubber pad must be between the bracket and the shell and used at all times.

2. Use a 10 mm Ring Wrench to tighten the M6 nuts. Do not overtighten.

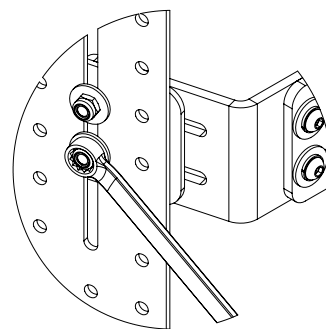
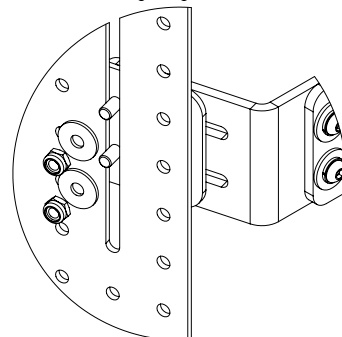

Width/height adjustment

1. Use a 10 mm Ring Wrench to loosen the M6 nuts.
2. Shift the Lateral into the desired position.
3. Tighten the M6 nuts

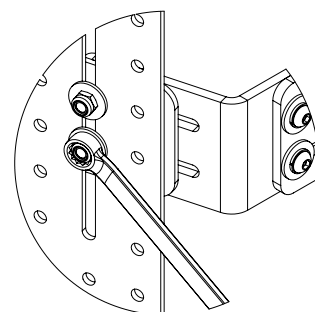

Mounting to Canes

When using Cane Mounts instead of the fixing plate, follow these steps:

1. Use a 4mm hex key (5mm for paediatric laterals) to remove 2 screws vertically aligned (1 screw for paediatric laterals).
2. Wrap the outer clamp around the cane in position and fasten firmly.

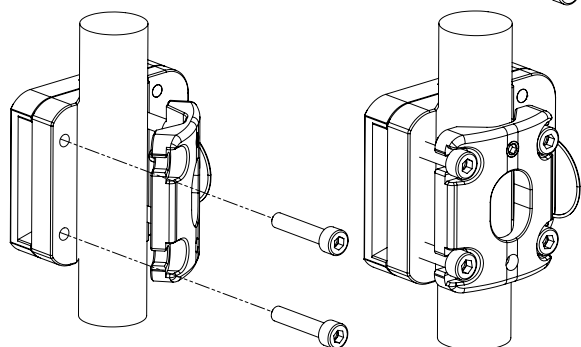
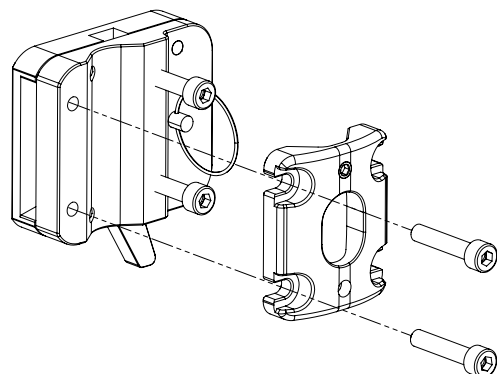

Added Depth Options

1. Optional extension bracket shown: #1266-2430-100

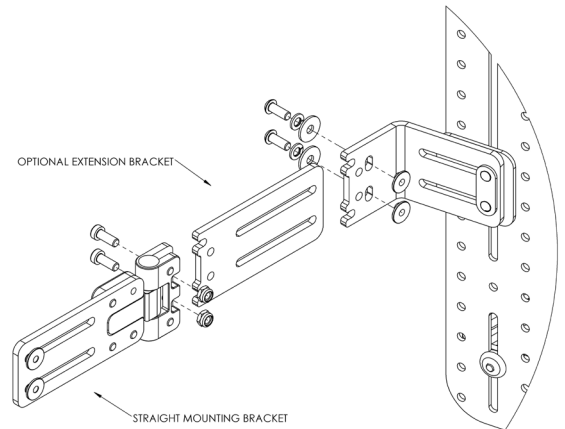

2. Use the extended bracket to adjust the depth of the Lateral as required. Ensure fasteners are tightened correctly.

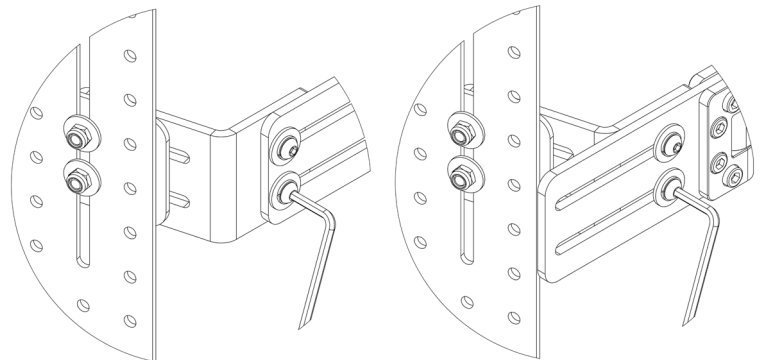

3. When using a Quick Release Lateral: Extra depth can be achieved by using the extended Axial bars provided as spare.

a) Remove the 4 buttonhead screws from the ends of the Axial bars

b) Swap the bars into the clamps

c) Refasten the 4 buttonhead screws onto the Axial bars

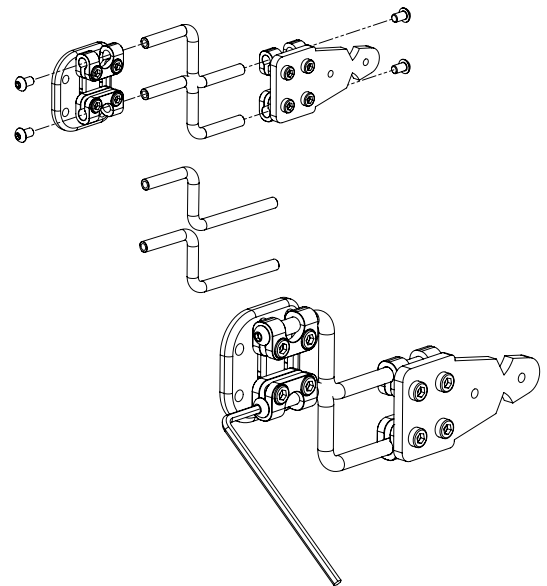

Angle adjustment

1. Adjust the **silver** screws to change the angle of the Lateral plate when positioning. Retighten once complete, ensuring the Lateral will not move.



WARNING

The silver screws must be tightened prior to the user sitting in the wheelchair.
The silver screws must be checked regularly for sufficient tightness.

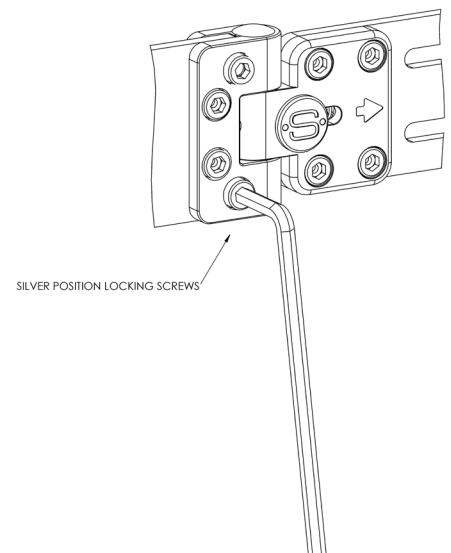

Depth adjustment

1. Remove the zipped cover and foam to adjust.
Use a 4 mm Hex key to adjust the position of the plate, by adjusting the two fasteners shown.

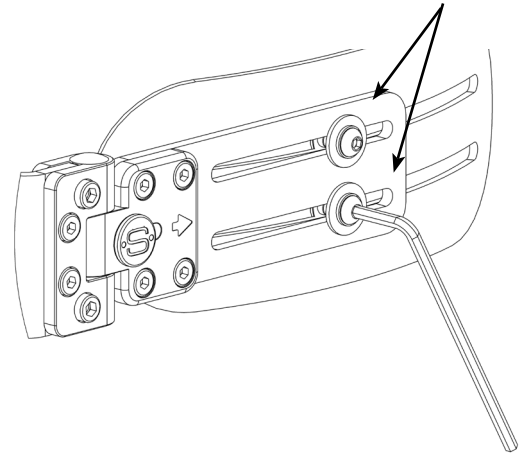

Axial adjustments (if fitted)

1. Use a 5 mm Hex key to adjust the angle and height of the plate.
Loosen the eight fasteners highlighted to position the plate as required.

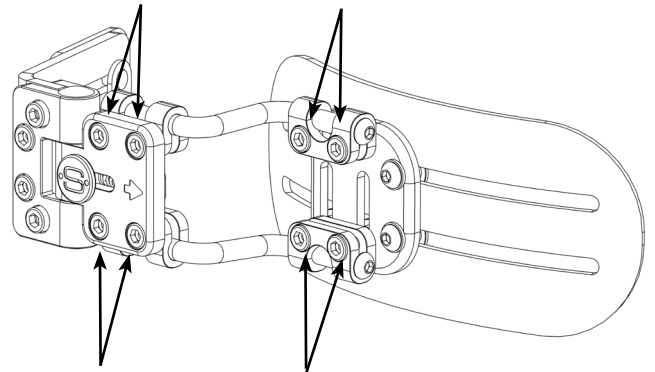

2. Use a 4 mm Hex key to adjust the position of the plate, by adjusting the two fasteners shown.

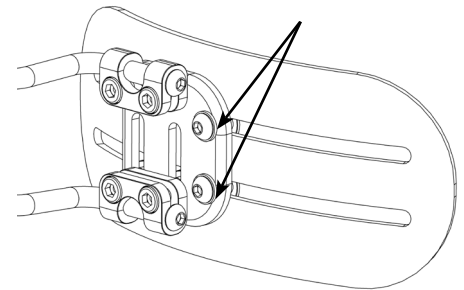

Releasing the swing-away mechanism

1. Slide the button across to open the Lateral.
2. To strengthen the Lateral bracket when there is a lot of force on the Lateral, the secondary bracket must be used as shown.

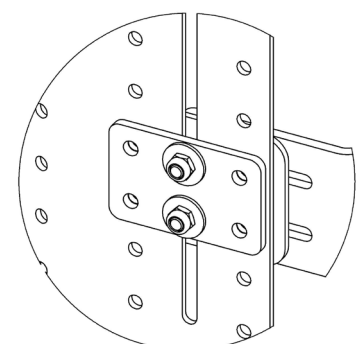
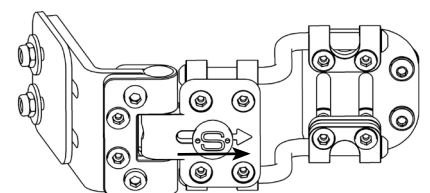

Releasing the Quick-Release mechanism (if fitted)

1. Pull the lever forward and remove the lateral.
2. To re-engage push into the mount until it clicks, locking itself in place.



WARNING

Ensure that the lateral is locked in place by trying to pull it away without activating the lever.

3. To fix the lateral and restrict removal insert the detent pin into the mechanism and ensure that it engages the tongue.



WARNING

Ensure that this has engaged, by trying to release the lateral. When using this support in transport the detent pin must be engaged.

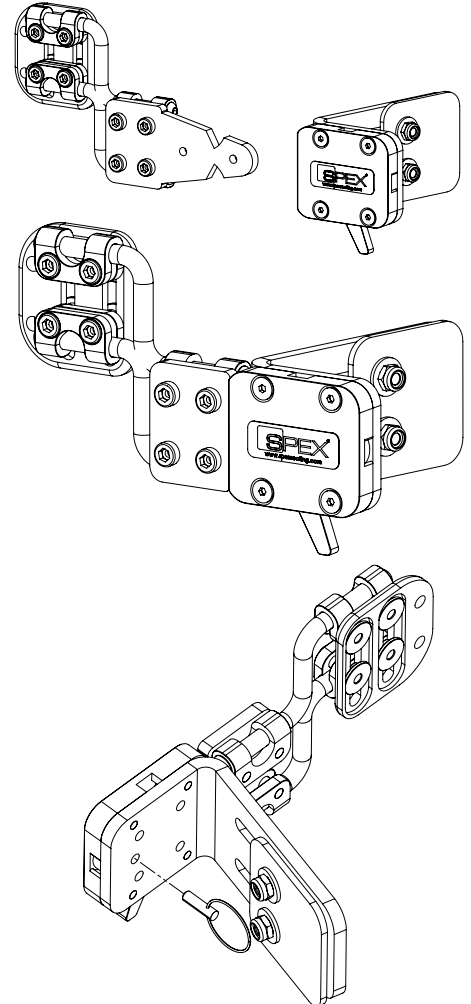

Biangular adjustments (if fitted)

1. Use a 4 and 5 mm Hex key to adjust the angle, height, pad curvature angle and depth of the Biangular lateral pad. Loosen the twelve fasteners highlighted to position the plates as required.
2. Correctly tighten the eight highlighted bolts to set the angle, height and curvature angle of the pad.

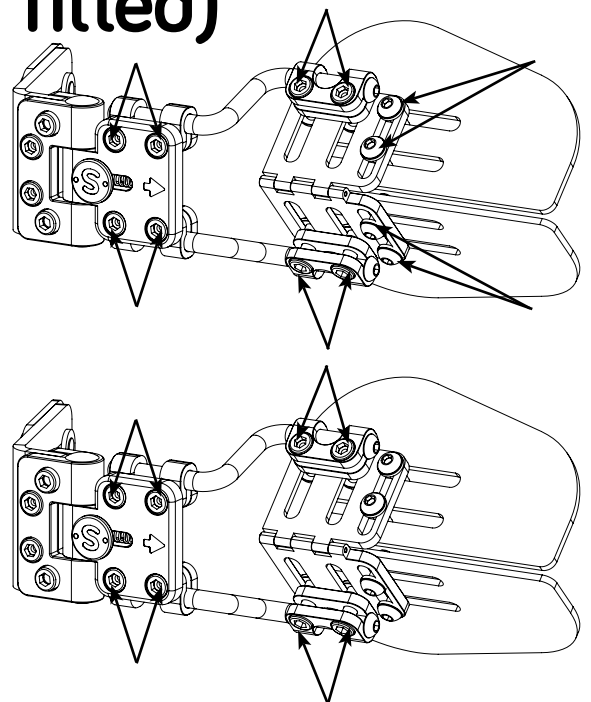

3. Lastly tighten the four fasteners shown to set the pad depth and secure the curvature angle.



WARNING

Ensure the four highlighted bolts are loosened enough prior to adjusting to allow them to slide freely along the slots. The bolts should then be tightened in a suitable position that does not create bunching or stretching of the foam.

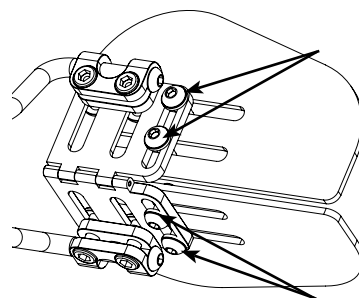

Re-issuing to another user

Once the user has finished using the Spex Lateral Support, it must be refurbished and thoroughly cleaned if it is issued to another user. Below are the strict guidelines for refurbishing the Spex Lateral Support.

Spex recommends using AHP (Accelerated Hydrogen Peroxide) disinfectant wipes. The disinfection product must be used as per the manufacturer instructions. Spex takes no responsibility for the effectiveness of the disinfecting process.

Spex takes no responsibility for contamination, cross infection, or damage.

Part	Procedure
Safety check	All components to be checked for signs of stress or cracking.
Upholstery covers	Upholstery outer covers must be replaced regardless of condition.
Hardware and components	Ensure the mechanism components are in place and in safe working order. If any are missing, they must be ordered. Check for signs of stress or cracking. If any stress/cracks are found the Lateral Support is to be retired from use and must be disposed of. Clean the hardware and components with a mild detergent and quality disinfectant such as the AHP (Accelerated Hydrogen Peroxide) disinfectant wipes, ensuring all areas are free from grime.
Foam	Foam pad must be replaced regardless of condition.

Disposal & Recycling

Your Spex Seating System is manufactured using a variety of materials, most of which can be recycled. Once it reaches the end of its life, if you are the legal owner, do not dispose of as ordinary household waste but take your Spex System to an approved recycling or collection point, to dispose of according to local laws and regulations.

Separate collection and recycling of the Spex System when disposing ensures protection of the environment and assists with natural resource conservation.

Transit Safety



WARNING

When using the Quick-Release Lateral Support in transit the detent pin must be engaged.

The Spex Seating System has been successfully crash tested and complies with RESNA WC-4:2012, Section 20 (WC20). The Spex Seating System meets the requirements of ISO 16840-4:2009 and is suitable for use as a motor vehicle seat when used with an appropriate wheelchair base. Please follow all installation, use and maintenance instructions within this manual as well as the following transit instructions. If feasible, the wheelchair user should transfer to the vehicle seat and use the vehicle-installed occupant restraint systems.

Spex Seating System has been designed to accommodate the proper use of vehicle-anchored belt restraints. Spex achieved a rating of Excellent (16 out of 16), for ease of properly positioning a belt restraint, and the degree to which proper belt restraint can be achieved, based on the methods of Annex D. The following items of the Spex Seating System have been tested and are suitable for use in a motor vehicle:

- Full Height Back Support Models
- Seat Base
- Cushion Models
- Arm and Thigh Supports
- Trunk Lateral Supports
- Head Supports

Note: Back Supports that are lower than the user's shoulder height are not certified and not recommended for transport in a vehicle. Eg. Vigour Lo and Vigour Mid Back Supports.

Assembly, Use, Maintenance & Limitations

- Adjustments to the set-up of the wheelchair must only be carried out by a qualified therapist, professional, or seating technician. Custom contoured/bespoke systems may require a qualified professional to configure and install the seating system.
- After carrying out any adjustments ensure all bolts, screws and nuts are securely fastened again to ensure safety when travelling in a vehicle.
- Ensure the top and bottom mounts of the backrest and the front and rear mounts of the seat pan are installed as far apart from each other as possible to give a stronger 4-point attachment to the wheelchair frame. Ensure the quick release latches are engaged.
- Do not use the Spex Seating System as a vehicle seat if seating components which have not been successfully crash tested are used anywhere on the seating system. Spex Seating is designed and certified using only Spex components. Spex is not liable in the event where other manufactured seating systems are used in conjunction with Spex Seating.
- At regular intervals check that all the fastenings on the Spex Seating System have not become loose during day to day use and re-tighten if necessary.
- Ensure the swing-away Laterals are in their locked position before using the seat as a vehicle seat in a motor vehicle.

Transit Safety

Correct Positioning of Belt Restraints

When using the Spex Seating System as a vehicle seat, both a pelvic-belt restraint and shoulder-belt restraint must always be used. To correctly position the belt restraints on the wheelchair occupant, the following must be ensured:

- The pelvic-belt restraint should be worn low across the front of the pelvis near the junctions of the pelvis and thighs.
- The angle of the pelvic-belt restraint should be between 30° to 75° relative to the horizontal and, ideally, between 45° to 75° to the horizontal (as shown in Figure 2).
- The belt-restraint buckle of three-point belt restraints should be placed in contact with the occupant’s body and away from wheelchair components.
- The junction of the shoulder-belt and pelvic-belt of three-point-belt restraints should be located near the hip opposite the shoulder over which the diagonal belt crosses and not near the midline of the occupant.
- Belt restraints should not be routed outside of the wheelchair wheels or over the wheelchair armrests, and should not be held away from the body by wheelchair components or parts.
- Upper torso belt restraints should fit directly over, and in contact with, the middle of the shoulder.
- Belt restraints should be adjusted to fit as snugly as possible, consistent with user comfort.
- Belt restraints should not be worn twisted in a manner that reduces the area of contact of the belt webbing with the occupant.



Figure 1

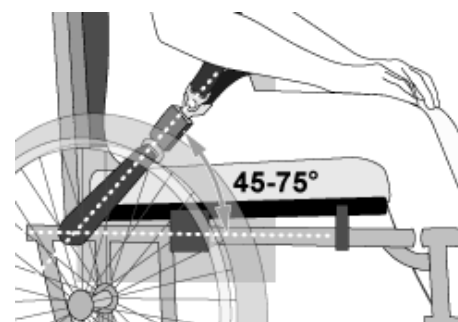

Figure 2



Figure 3a - Improper positioning of pelvic-belt restraints over wheelchair supports.

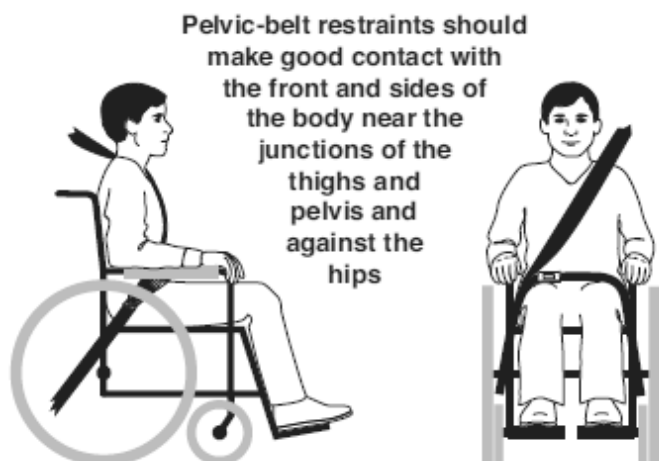

Figure 3b - Proper routing and positioning of belt restraints on the wheelchair occupant.

**WARNING**

- 1. The distance between the top of the user's shoulder and the top of the back should not exceed 6.5" (16.5 cm).**
- 2. The Spex Seating System must only be used with wheelchair bases that are tested as part of a wheelchair system that conforms to performance requirements of ISO 7176-19 and RESNA WC-4:2012, Section 19.**
- 3. The Spex Seating System should only be used on wheelchair frames that provide four securement points and pelvic-belt anchor points that conform to the requirements of RESNA WC-4: 2012, Section 19.**
- 4. The wheelchair must be labelled as appropriate for use as a seat in a motor vehicle, dynamically tested to the performance requirements of ISO 7176-19 and installed, used and maintained according to the manufacturer's instructions.**
- 5. The Spex Seating System must only be used as indicated in this user manual.**
- 6. Both pelvic and shoulder-belt restraints as a part of a complete Wheelchair Tie down and Occupant Restraint System (WTORS) which meets ISO 10542-1 shall be used to achieve effective occupant restraint and optimum protection in a vehicle impact; the belt restraints should be compatible with the specific wheelchair, and fitted to the user in accordance with WTORS manufacturer's instructions.**
- 7. Back Supports with adjustable recline angles should not be tilted back more than 30° beyond the vertical during travel in vehicles unless necessary for the medical and postural needs of the occupant.**
- 8. If the Back Support must be adjusted to an angle that is greater than 30° beyond the vertical during travel, the upper shoulder-belt anchor point should be adjusted rearward to maintain belt**

**WARNING**

8. cont... contact with the wheelchair occupant's shoulder and chest.
9. The Spex Seating System must only be used for forward-facing seating in motor vehicles.
10. In order to reduce the potential of injury to vehicle occupants, wheelchair-mounted rigid trays not specifically intended for use during travel in motor vehicles must be:
 - a. Removed and secured separately in the vehicle or
 - b. Secured to the wheelchair so they will not break free in a crash and
 - Be positioned with a gap of at least 3" (75 mm) between the back edge of the tray and the wheelchair occupant's abdomen and/or chest so as not to interfere with the proper belt-restraint use, and
 - Have energy absorbing padding placed between the back edge of the tray and the wheelchair occupant.
11. Alterations or substitutions must not be made to the seating system structure, parts or components, without first consulting Spex.
12. The use of a postural pelvic belt attached to the wheelchair base or seat frame is encouraged during travel, but these belts should be positioned so that they don't interfere with the proper positioning of crashworthy belt restraints, and they should not be relied on for occupant protection in crash situations unless the postural belt has been designed to comply with, and perform to the requirements of WC19.
13. Postural support devices that are not labelled as conforming to ISO 16840-4 may be used when in a vehicle, but should not be relied on for occupant restraint.

 **WARNING**

14. Both pelvic-belt and shoulder-belt restraints that comply with WC18 and/or WC19 should be used to limit occupant movement in a crash and reduce the likelihood of occupant ejection from the vehicle and/or injurious contact of the occupant with the vehicle interior.
15. Belt restraints should be positioned on the wheelchair occupant in accordance with WTORS manufacturer's instructions.
16. Backrest mounting hardware must be installed correctly. Refer to the appropriate section for correct backrest hardware mounting instructions.
17. If the wheelchair is being transported while occupied, the wheelchair must still be secured to the WTORS.
18. Children whose mass is less than 48.5 lbs. (22 kg) should be transferred from their seating system into appropriate child restraint systems intended for use in motor vehicles.
19. Sufficient forward and rearward clear space should be provided around the wheelchair occupant. Forward clear-space zone (FCZ) needs to be larger when a shoulder-belt restraint is not used.

FAILURE TO HEED THESE WARNINGS COULD CAUSE SEVERE INJURY TO THE WHEELCHAIR USER OR OTHERS.

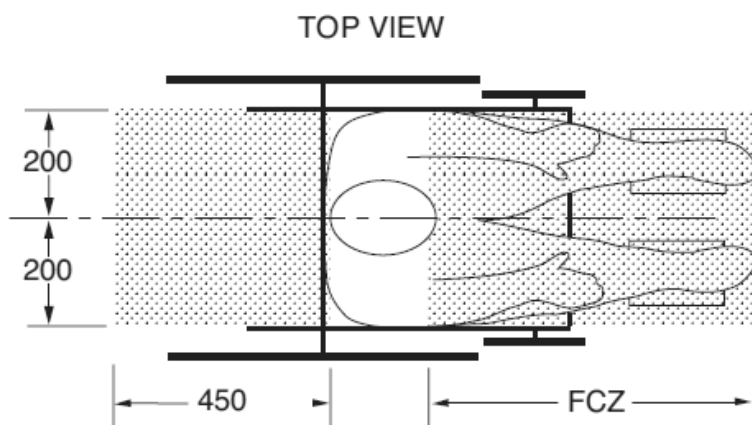

NOTES: The rear clear zone is measured from the rearmost point on an occupant's head. The front clear zone is measured from the frontmost point on an occupant's head.

Seated head height (HHT) ranges from about 47" (1200 mm) for a small adult female to about 61" (1550 mm) for a tall adult male.

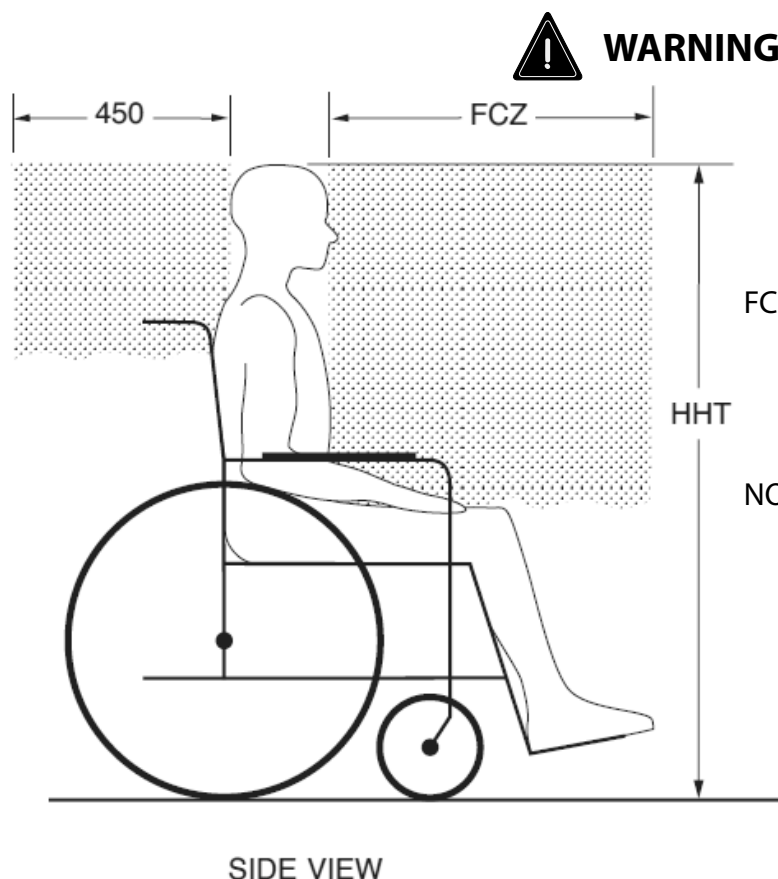

FCZ = 25.5" (650 mm) with upper torso restraint
 = 37" (950 mm) with only pelvic restraint

NOTE: It is strongly recommended that both pelvic and upper torso belts be used.

Recommended forward and rearward clear zones for wheelchair seated occupants. (Note: the FCZ may not be achievable for wheelchair seated drivers).

Warranty

Each Spex Lateral Trunk Support is carefully inspected to provide peak performance and is guaranteed to be free from defects in materials and workmanship for a period of 12 months from the date of purchase, provided normal use. Should a defect in materials or workmanship occur within 12 months from the original date of purchase, Spex will, at its option, repair or replace it without charge. This warranty applies to the Lateral Trunk Support components including the pad, cover and hardware. This warranty does not apply to general wear and use, including punctures, tears or burns or customer abuse of any of the Lateral Trunk Support components.

Claims and repairs should be processed through the nearest authorized Spex supplier. Except for express warranties made herein, all other warranties, including implied warranties of merchantability and warranties of fitness for a particular purpose are excluded. There are no warranties which extend beyond the description on the face hereof. Remedies for breach of express warranties herein are limited to repair or replacement of the goods. In no event shall damages for breach of any warranty include any consequential damages or exceed the cost of non-conforming goods sold. The serial number of your Lateral Trunk Support can be located by unzipping the Lateral Support pad cover.

Technical Data

Weight Limit: 136 kg (300 lb). Paediatric Lateral Support: 50 kg (110 lb).

Bracket Weight: Between 0.15 – 0.45 kg (0.3 – 1 lb)

Pad Weight: Between 0.05 - 0.3 kg (0.1 – 0.7 lb)

Materials

Hardware: Aluminium

Cover: PU Foam, EVA Foam, Nylon, Polyester

Fixed and Axial Lateral Hardware

	Depth Adjustment
Axial Hardware	55 mm
Paediatric Hardware	60 mm
Fixed Hardware	55 mm
Kidz Fixed Hardware	40 mm

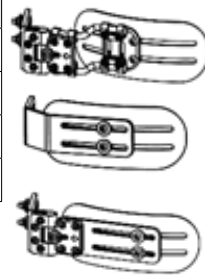

Axial Technology

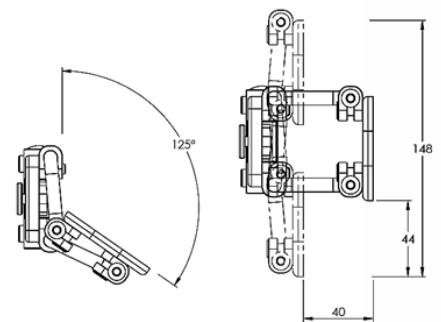

Swing-Away Hardware

Standard	Overall Length	Plate Length
Swing-away, straight	175 mm	120 mm
Swing-away, straight extended	205 mm	150 mm

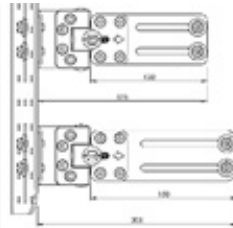

Offset	Offset
Swing-away, offset	20 mm
Swing-away, offset extended	40 mm

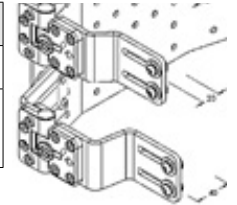

Lateral Support Pads

Narrow Straight

Size	Pad Height	Pad Depth
0	85 mm	115 mm
1	95 mm	145 mm
2	95 mm	180 mm
3	115 mm	210 mm
4	115 mm	240 mm

Narrow Curved

Size	Pad Height	Pad Depth
1	95 mm	145 mm
2	95 mm	180 mm
3	115 mm	210 mm
4	115 mm	240 mm

Broad

Size	Pad Height	Pad Depth
1	105 mm	130 mm
2	125 mm	140 mm
3	140 mm	150 mm
4	160 mm	155 mm
5	195 mm	165 mm
6	230 mm	175 mm



32 Detroit Drive
Rolleston 7675
New Zealand



Spex Ltd
Phone +64 3 307 9790
Fax +64 3 307 2820
fasterresults@spexseating.com
www.spexseating.com

US	REP
Medicept 200 Homer Ave, Ashland, MA 01721 United States Tel: +1-508-231-8842	

EC	REP
BEO MedConsulting Berlin GmbH Helmholtzstr. 2 D-10587 Berlin, Germany Tel: +49-30-318045-30	