

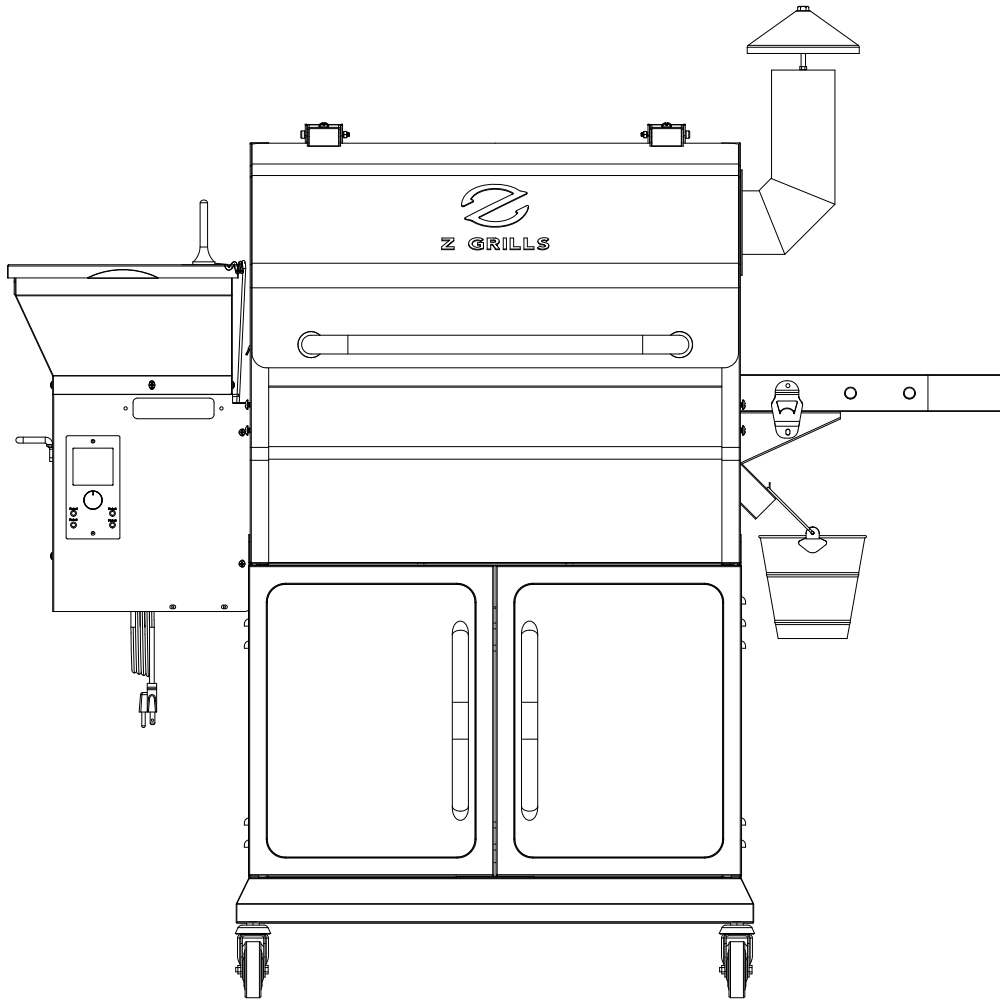

**Z GRILLS**



---

**WOOD PELLET GRILLS**

---

**ZPG-1000D4E**

---

**OWNER'S MANUAL**

**MON TO FRI, 8:00 A.M. - 5:00 P.M. PACIFIC STANDARD TIME**

**SERVICE CONTACT: 1-833-947-4557/1-833-ZGRILLS**

**EMAIL: [support@zgrills.com](mailto:support@zgrills.com)**

**WEBSITE: [www.zgrills.com](http://www.zgrills.com)**





# ***CONTENTS***



<b>IMPORTANT SAFETY INFO</b>	<b>3</b>
<b>COMPONENT LIST</b>	<b>6</b>
<b>ASSEMBLY INSTRUCTIONS</b>	<b>8</b>
<b>INITIAL FIRING INSTRUCTIONS</b>	<b>18</b>
<b>SUBSEQUENT START-UP</b>	<b>19</b>
<b>OPERATING TIPS</b>	<b>20</b>
<b>MAINTENANCE &amp; CLEANING</b>	<b>21</b>
<b>TROUBLESHOOTING</b>	<b>23</b>
<b>DIGITAL THERMOSTAT CONTROL WIRING DIAGRAM</b>	<b>25</b>
<b>Z GRILLS SUPPORT</b>	<b>27</b>
<b>3-Y LIMITED WARRANTY</b>	<b>28</b>



**SAVE THIS MANUAL FOR FUTURE REFERENCE**

# **IMPORTANT SAFETY INFO**

## **GENERAL WARNINGS**

**Please read this entire manual before installation and use of the pellet fuel-burning appliance. Failure to follow these instructions could result in property damage, bodily injury or even death.**

**Contact local building or fire officials about restrictions and installation inspection requirements in your area.**

**This grill is for outdoor use only. DO NOT use it in any enclosed area.**

**DO NOT store or use combustible materials or liquids near this appliance.**

**Keep children away while it is in use.**

**Maintain a safe distance between your grill and any combustible material.**

**DO NOT move your grill while operating or while it is hot. Wait until the grill is completely cold.**

**If a grease fire occurs, turn “off” and leave lid closed until the fire is extinguished. DO NOT unplug the power cord. DO NOT throw water on it. DO NOT try to smother the fire.**

**Clean and maintain your grill after each use.**

**DO NOT use your grill on rainy days.**

**DO NOT touch any part of your grill while it is hot. Serious bodily injury could result.**

**We suggest the use of heat-resistant gloves when operating this grill.**

**We suggest that you should wrap the Grease Drain Pan with heavy-duty aluminum foil before using because it is easy to clean.**

**For convenient and safe assembly, use at least two people to assemble the grill.**

**Make sure the power cord is disconnected before performing any service or maintenance.**

**DO NOT** place anything heavy on top of hopper lid. It is not a shelf and is a tip hazard.

**Never use gasoline, gasoline-type lantern fuel, kerosene, charcoal lighter fluid, or similar liquids to start or 'freshen up' a fire in this appliance. Keep all such liquids well away from the appliance when in use.**

**Do not use accessories not specified for use with this appliance.**

**NOTE: A MAJOR CAUSE OF FIRES IS FAILURE TO MAINTAIN REQUIRED CLEARANCES (AIR SPACES) TO COMBUSTIBLE MATERIALS. IT IS OF UTMOST IMPORTANCE THAT THIS PRODUCT BE INSTALLED ONLY IN ACCORDANCE WITH THESE INSTRUCTIONS.**

## **PELLET RESTRICTIONS**

**This grill is designed for use of wood pellets only designed for burning in wood pellet grills. Do Not Use Pellet Fuel Labeled As Having Additives.**

**We suggest that you use Z GRILLS BBQ WOOD PELLETS, which are specifically made to work in our grills. There is no guarantee that other brands of pellets are suitable for use in Z GRILLS. And Z GRILLS assumes no liability for any loss, damage or injury caused by the use of any other brands of pellets.**

**Always keep the Pellet Hopper dry, the wood pellets will expand greatly, break apart and even jam the feed system if the pellets get wet or are exposed to high humidity.**

## **CARBON MONOXIDE WARNING**

**Follow these guidelines to prevent this colorless, odorless gas from poisoning you, your family or others.**

**Know the symptoms of carbon monoxide poisoning: headache, dizziness, weakness, nausea, vomiting, sleepiness, and confusion. Carbon monoxide reduces the blood's ability to carry oxygen. Low blood oxygen levels can result in loss of consciousness and death.**

**See a doctor if you or others develop cold or flu-like symptoms while cooking or in the vicinity of this appliance. Carbon monoxide poisoning, which can easily be mistaken for a cold or flu, is often detected too late.**

**Alcohol consumption and drug use increase the effects of carbon monoxide poisoning.**

**Carbon monoxide is especially toxic to mother and child during pregnancy, infants, the elderly, smokers, and people with blood or circulatory system problems, such as anemia, or heart disease.**





## COMPONENT LIST



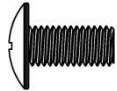
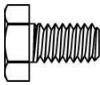
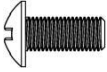

ITEM	QTY	DESCRIPTION
1	1	Grill Chamber
2	1	Lid Handle
3	1	RTD Temperature Probe
4	1	Heat Baffle
5	1	Top Warming
6	2	Middle Warming
7	2	Porcelain Grills
8	1	Body Frame
9	1	Grease Drain
10	1	Grease Bucket
11	1	Side Shelf
12	1	Ash Tray
13	1	Ash Tray Handle
14	1	Smoke Stack Gasket
15	1	Smoke Stack
16	1	Chimney Cap
17	1	Hopper Lid
18	1	Hopper Guard
19	1	Hopper Bottom Shell
20	1	Digital Control
21	1	Hopper Bottom Cover
22	1	Power Cord Collector
23	1	Auger Drive Motor
24	1	Auger Tube Bushing
25	1	Power Cord
26	1	Auger
27	1	Thick Gasket
28	1	Hot Rod(Ignitor)
29	1	Firepot Assembly
30	1	Hopper Burner Assembly
31	1	Fan
32	1	Visible Window

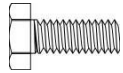
ITEM	QTY	DESCRIPTION
33	1	Hopper Burner Gasket
34	1	Left Plate
35	2	Left Door Upper Pivot
36	1	Left Door
37	2	Bottom Pivot
38	1	Magnet Fixing Plate
39	1	Beam
40	2	Magnet
41	1	Back Board
42	1	Platform
43	2	Door Handle
44	1	Right Door
45	1	Right Plate
46	2	Wheels(with brake)
47	2	Wheels (without brake)
48	1	Hopper Top Assembly
49	1	Hopper Handle
50	1	Hopper Bottom Assembly
51	1	Grease Drain Pan Support
52	1	Hopper Top Shell
53	2	Lid Hinge
54	2	Chamber Hinge
55	2	Nut
56	2	Axle
57	1	Front decoration
58	1	Lid
59	2	Lid Guide
60	1	Winding Handle
61	1	Pellet Cleanout Door
62	1	Botter Opener
63	1	WIFI Antenna

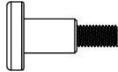

# HARDWARE PACKAGE LIST

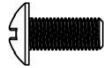
ITEM	QTY	DESCRIPTION
A	26	 Bolt 1/4-20×1/2
B	6	 Hexagon Bolt 1/4-20×1/2
C	4	 Bolt 8#-32×4/17
D	4	 Hexagon Kep Nut 8#-32
E	4	 Hexagon Bolt 1/4-20×3/4
F	12	 Gasket (OD0.79×ID0.33)
G	2	 Hex Nut 1/4-20

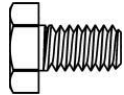
ITEM	QTY	DESCRIPTION
H	2	 Step Screw 8#-32
I	2	 Flange Bolt 1/4-20
J	6	 Bolt 8#-32 ×3/8
K	2	 Open End Wrench
L	1	 Screwdriver
M	2	 Hexagon Bolt 1/4-20×3/5

# ASSEMBLY INSTRUCTIONS

## PARTS DIAGRAM

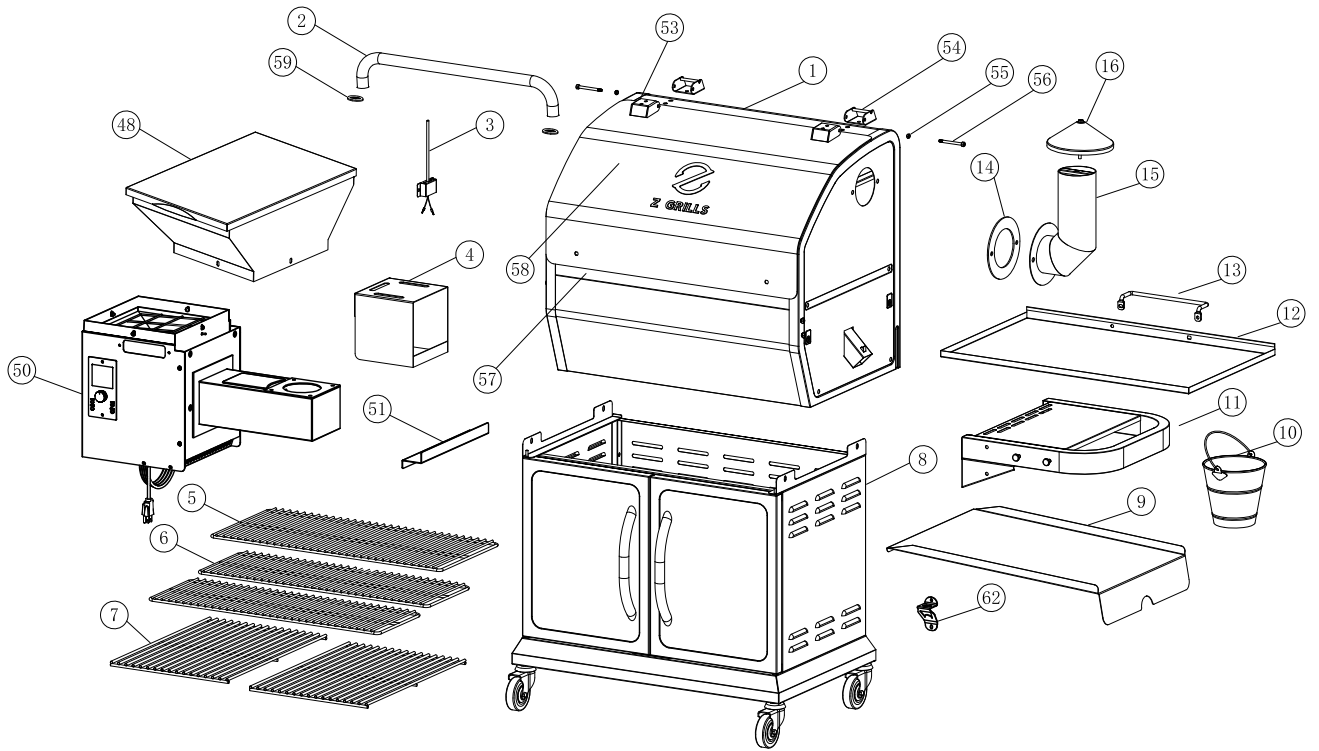

## HOPPER BURNER ASSEMBLY

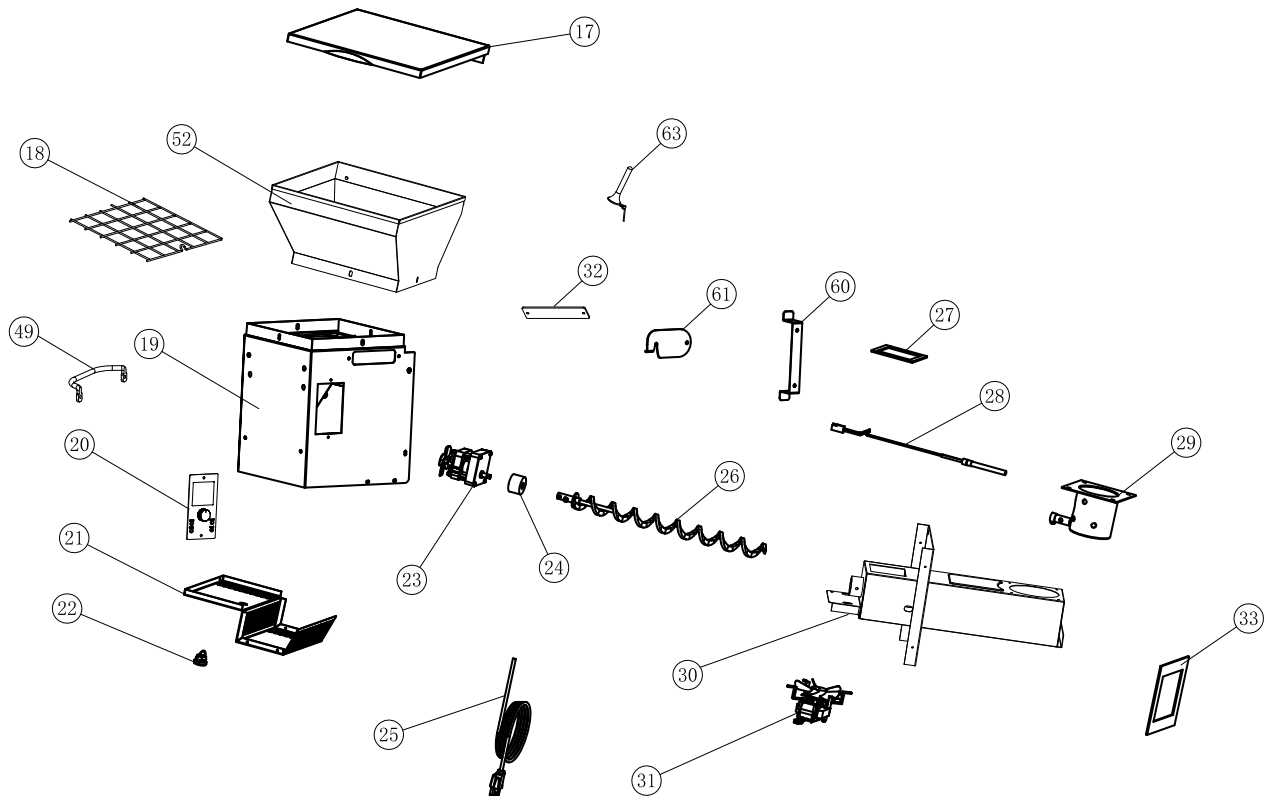

## BODY FRAME ASSEMBLY

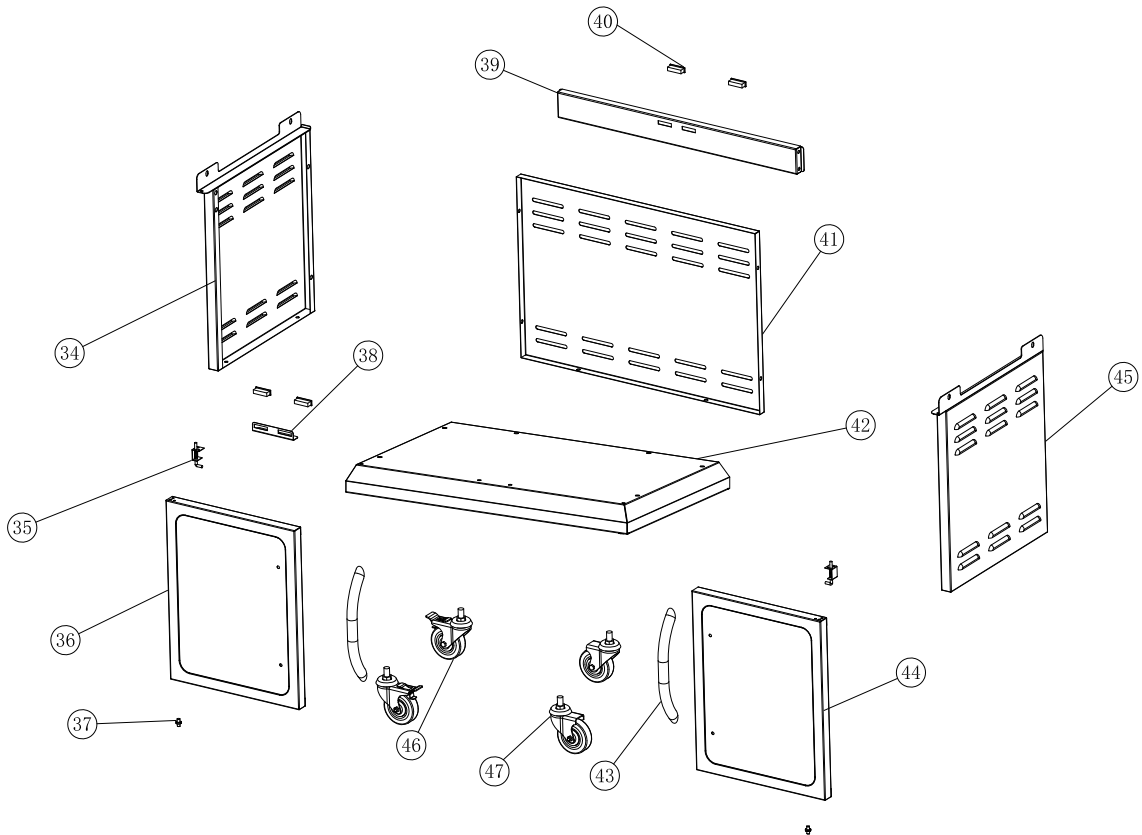

### 1.ASSEMBLING OF BOTTOM BASE

1. Turn the Platform (42) upside down. Install the wheels (without brake)(47) in the screw holes. Tighten with wrench. Note: The 2 wheels (without brake)(47) should be installed on the side near the magnet base. And the 2 wheel (with brake)(46) should be installed on the other side.

2. Assemble the Magnet Fixing Plate (38) to the Platform (42).

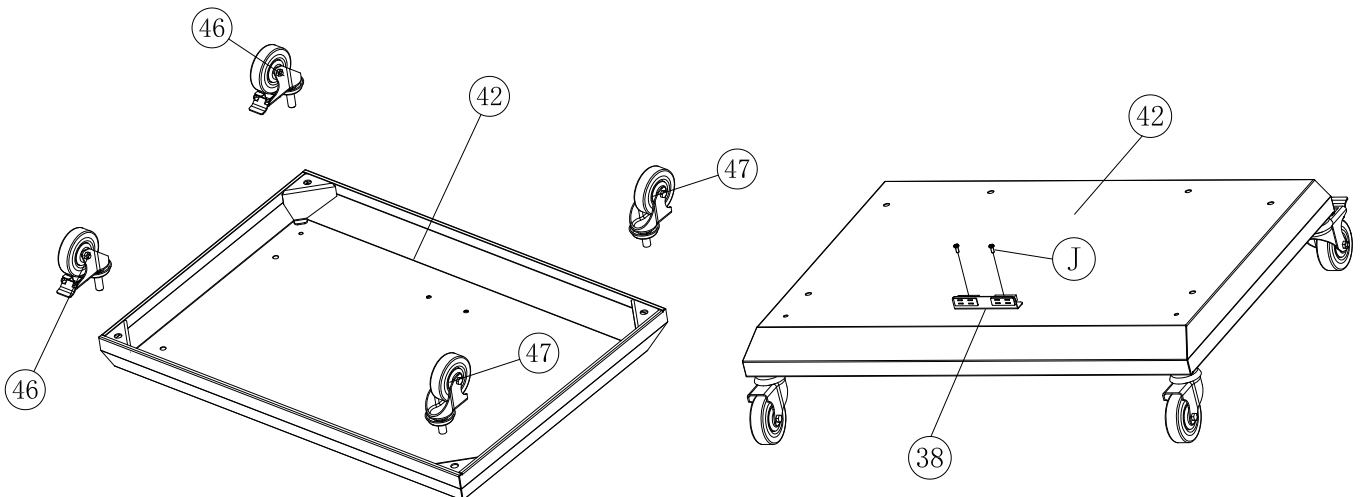

## 2.MOUNTING THE BODY FRAME

- 1.Secure Left Plate (34) on the Platform (42) with Bolt (A).
- 2.Secure Right Plate (45) on the Platform (42) with Bolt (A).
- 3.Secure Back Board (41) on the Platform (42) with Bolt (A) and link with Left Plate (34) and Right Plate (45).
- 4.Locate the Beam (39) between Left Plate (34) and Right Plate (45) with Bolt (A).

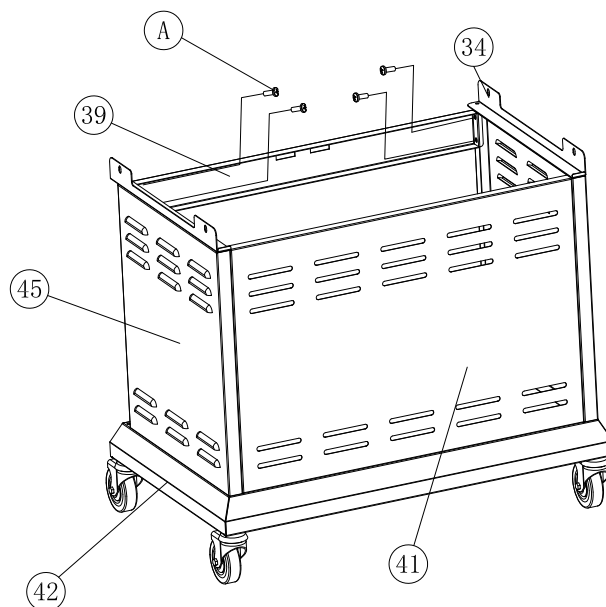
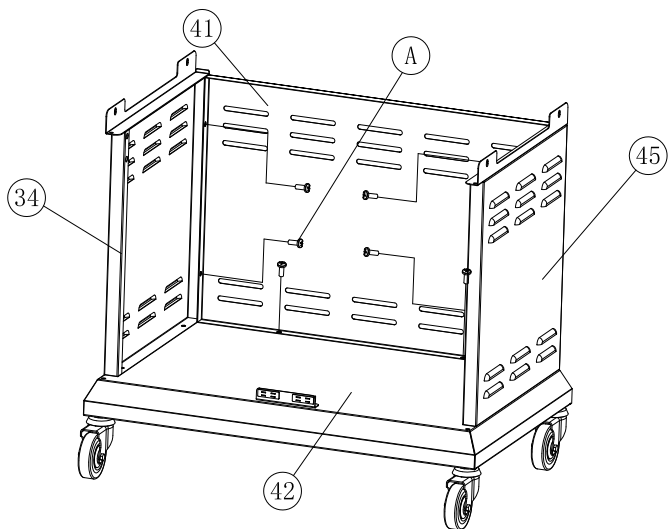
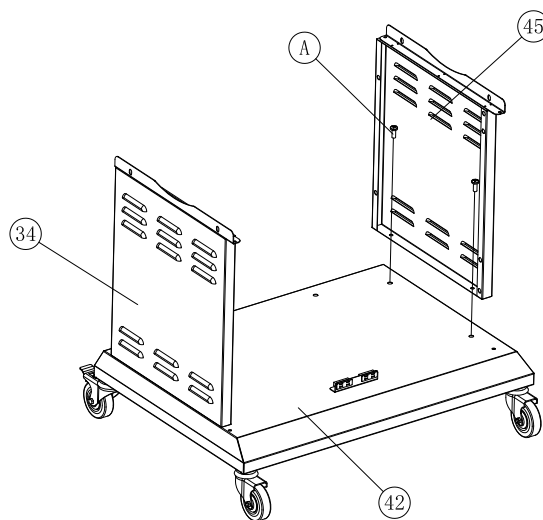
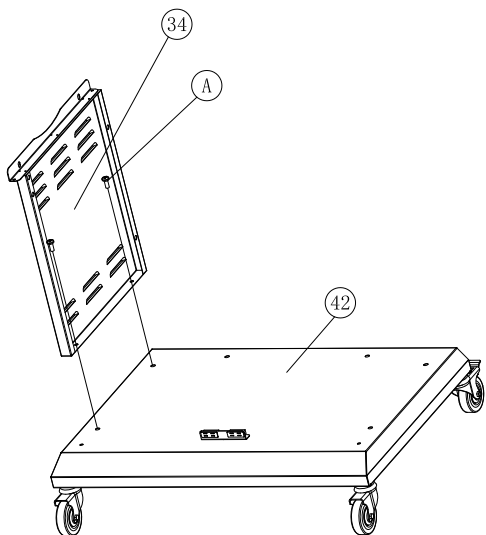

### 3.ASSEMBLING OF HOPPER

- 1.Insert Hopper Top Assembly (48) into Hopper Bottom Assembly (50), align the holes. Make sure hopper opens to the front (control side). Insert the Bolts (C) through the holes in the Hopper and Hexagon Nuts (D), then open the Hopper Lid and tighten it from inside. The four sides are installed in the same way.
- 2.Insert Bolt (A) through the Hopper Handle (49) and into the Hopper.

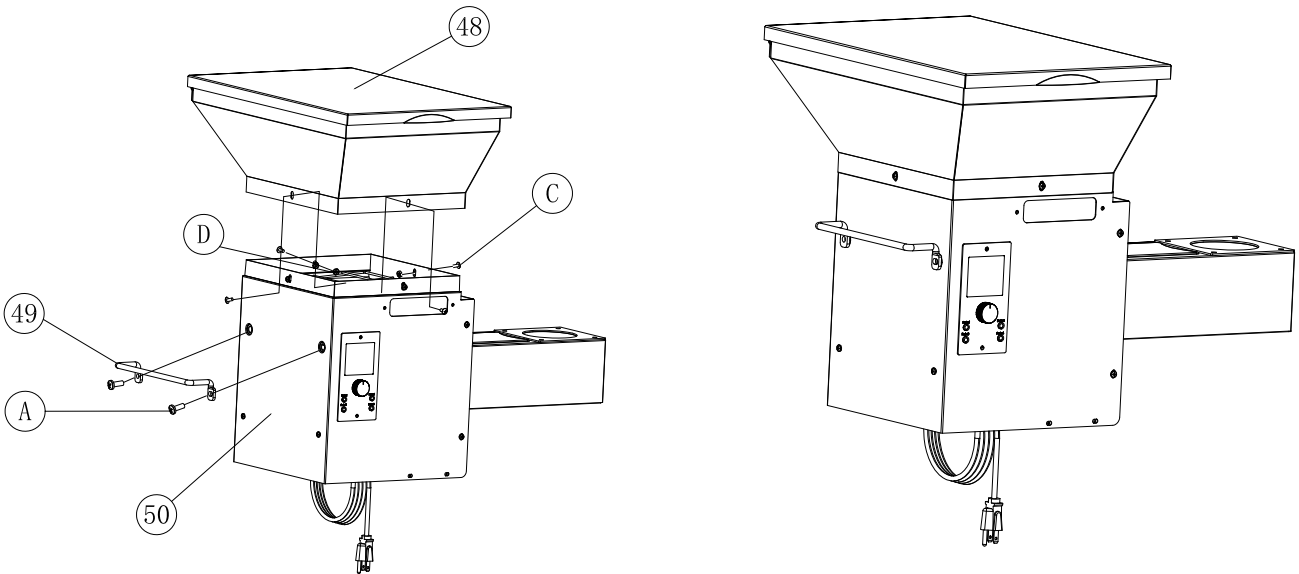

### 4.POSITIONING THE CHAMBER ON THE BODY FRAME

- 1.Remove the two Protection Bar under the Grill Chamber (1) with screwdriver.
- 2.Remove Bolts (A) from the Grill Chamber (1). Lift up the Grill Chamber (1) on the Body Frame. Make sure that the Grill Chamber (1) is between the left and right plate of the Frame. Align the Chamber holes with the plate holes and secure with Bolt (A).

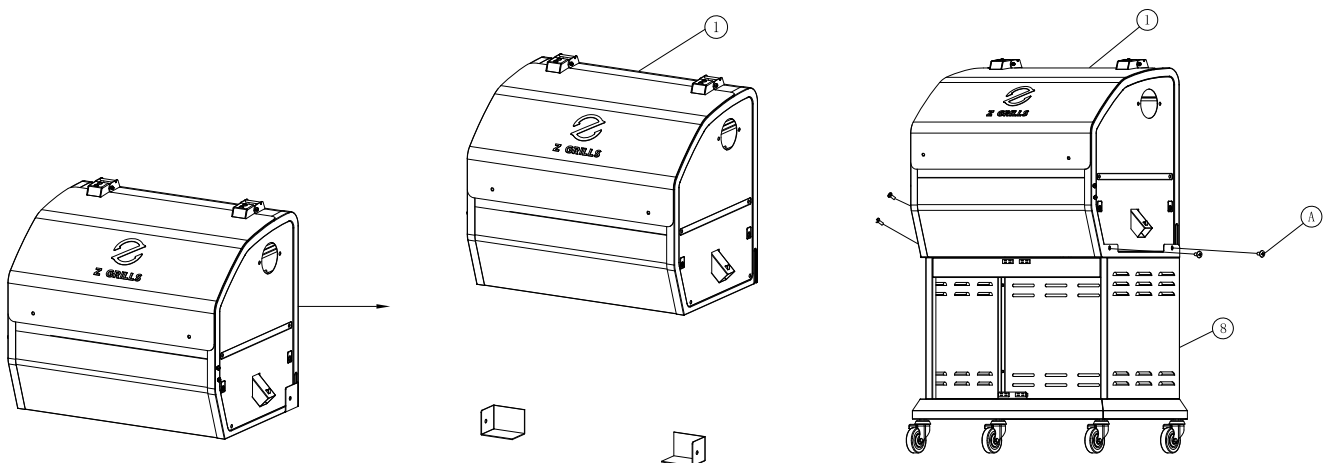

## 5.MOUNTING THE HOPPER TO THE CHAMBER

- 1.Open the Lid, insert the Hopper into the Chamber, then using the Bolts (E) and Gaskets (F) install it in sequence from inside. Note: the upper pair of Bolts and Gaskets need to be threaded through the Grease Drain Pan Support (51).
2. Locate the RTD plug-in connector coming from the mounted RTD inside the grill frame. Connect this with the mating connector located on the outside of the hopper burner assembly. NOTE: excess wire on the RTD plug should remain outside the Chamber.

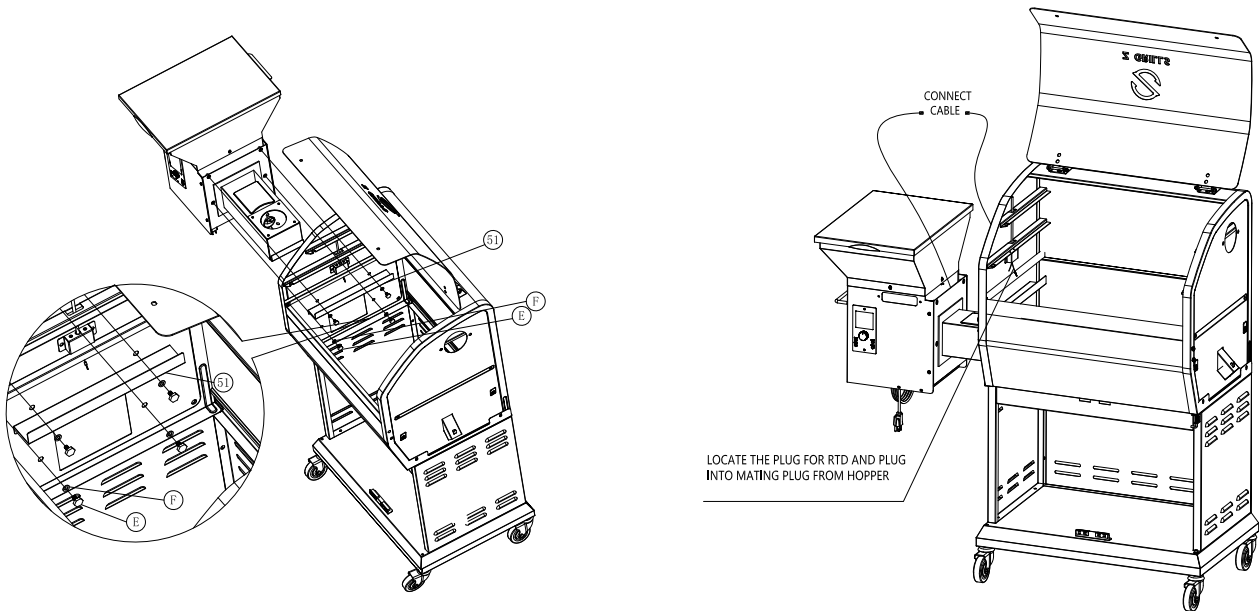

## 6.ATTACHING THE SMOKE STACK AND CHIMNEY CAP

- 1.Align the holes in the Smoke Stack (15) with holes in the Smoke Stack Gasket (14), which fits between the right end of the Grill and the Smoke Stack Gasket (14). Insert the Hexagon Bolts (B) through the holes in the Smoke Stack (15) and the Smoke Stack Gasket (14).
- 2.Place a Gasket (F) on each Bolt (B) and secure with Hexagon Nut (G).
- 3.Install the Chimney Cap (16) to Smoke Stack (15).Note that the Chimney Cap (16) is vertical and then tighten.

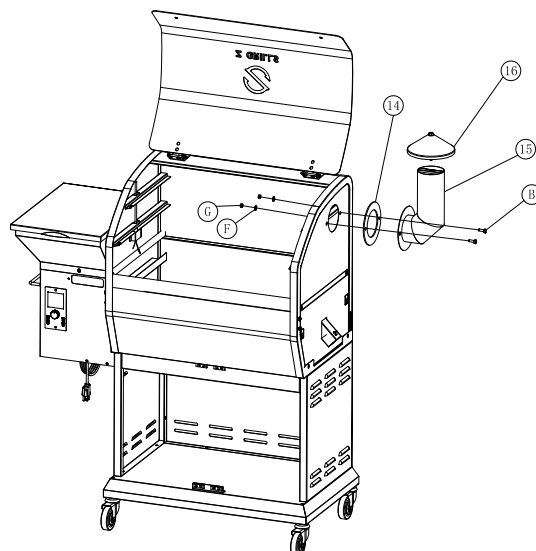

## 7.POSITIONING THE DOOR

1.Align the holes in the Left Door (36) with the holes in the Handle (43). Place a Gasket (F) on each Hexagon Bolt (B) and tighten with Wrench. Repeat the former step to assemble the Right Door (44).

2.Take the Left Door (36) with handle assembled. First insert the Bottom Pivot into the small hole on Platform (42). Then pull down the pivot until the upper end is aligned with top edge of the door. Then align the pivot with the upper hole and pull up the pivot to secure the door.

3.Repeat Step 1 to secure the Right Door (44). Make a proper adjustment until the doors can be firmly closed.

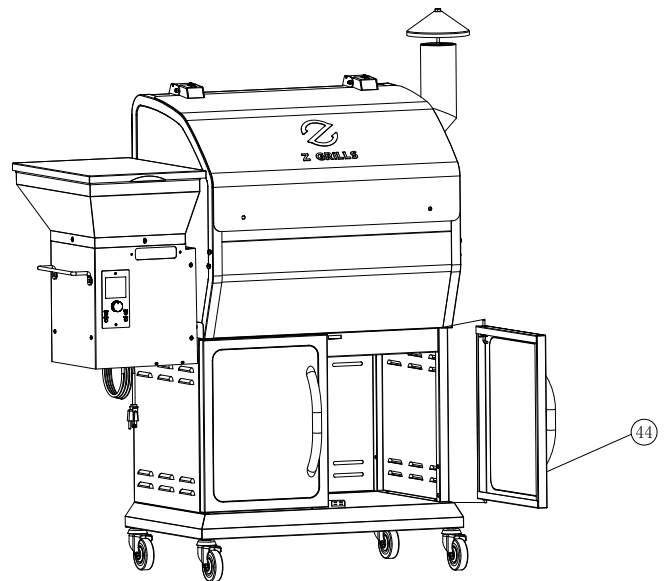
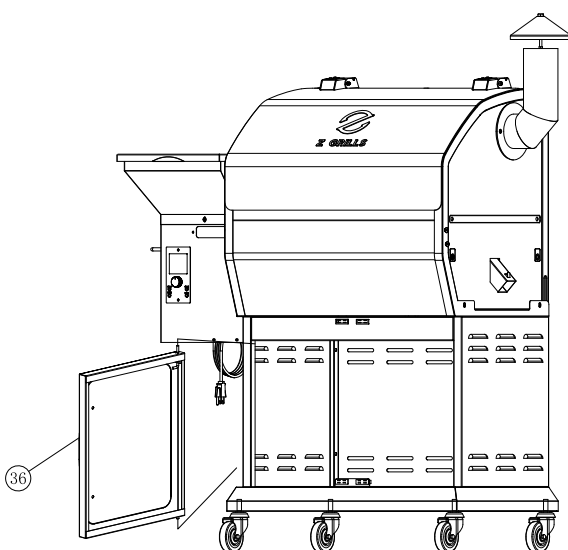
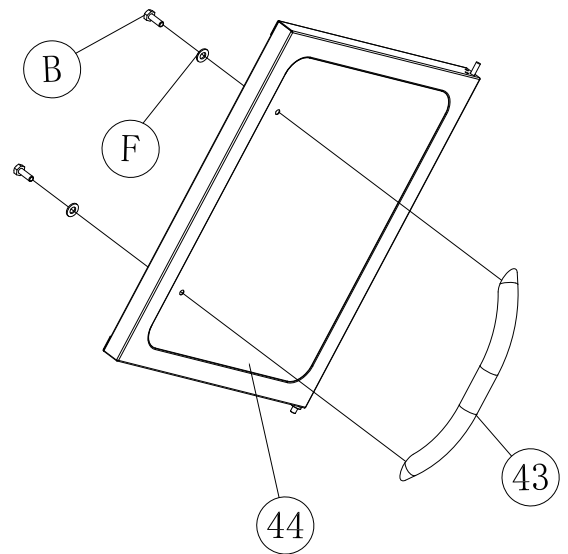
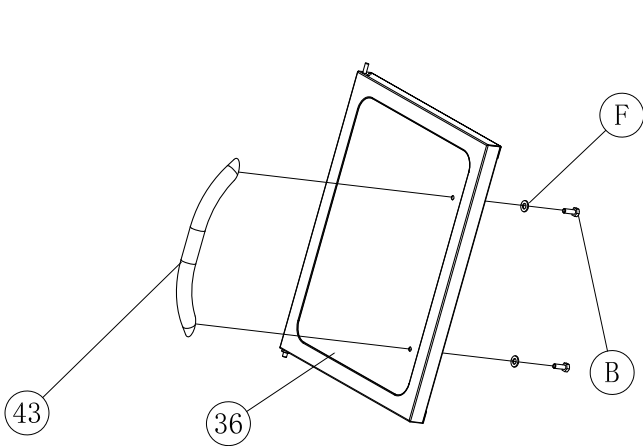

## 8.POSITIONING THE HEAT Baffle

Position The Heat Baffle (4) on the locating brackets which are on the inside walls of the Grill. The notched legs should be facing downward.

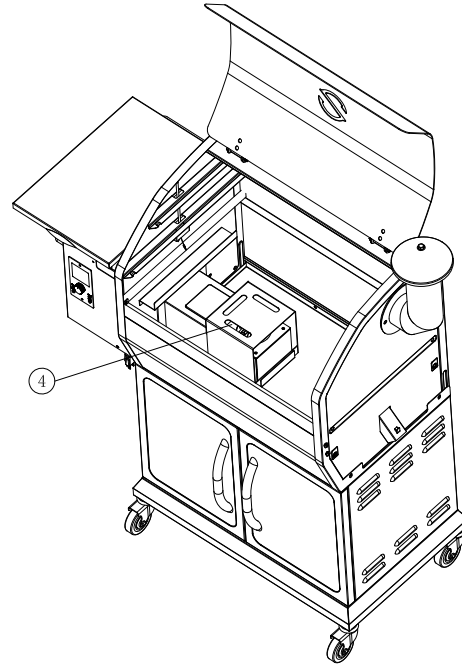

## 9.ATTACHING SIDE SHELF

- 1.Use two Bolts (A) to install the Side Shelf (11) from the inside of the Grill Chamber(1).
- 2.Insert the Step Screws (H) into the Side Shelf (11).
- 3.Use two Bolts (A) to install the Side Shelf (11) from the outside of the Grill Chamber (1).

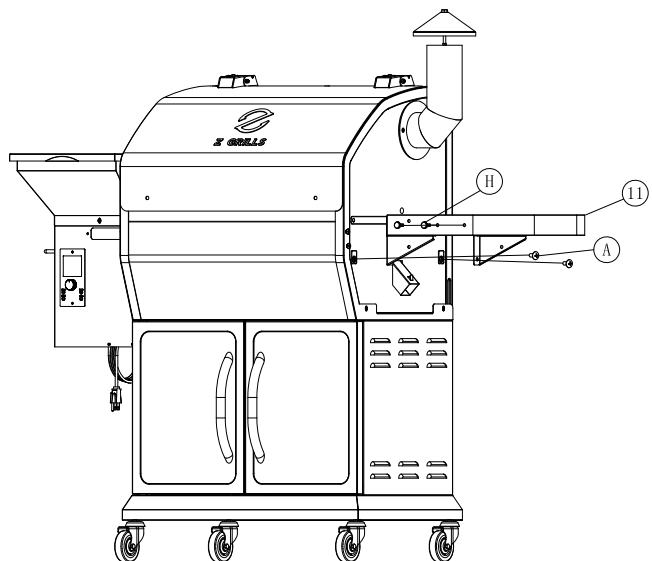
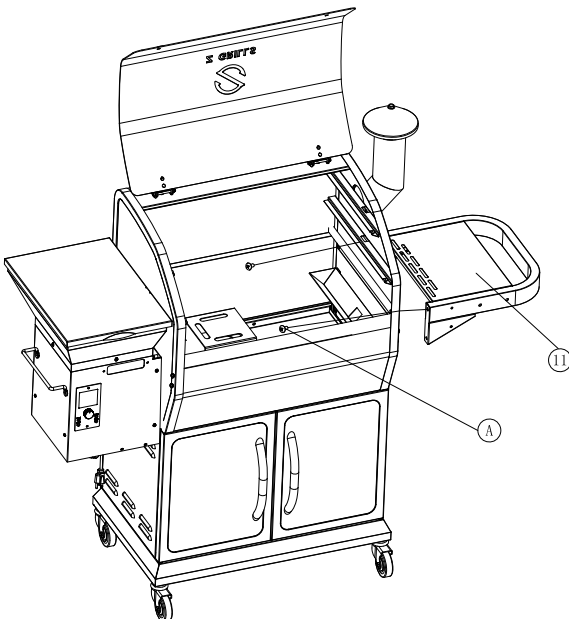



## 10.POSITIONING THE GREASE DRAIN PAN

Position The Grease Drain Pan (9) over the Firepot. The notched legs of the Grease Drain Pan should be facing downward to fit onto the locating brackets so that the grease can flow into the Grease Drain Tube.

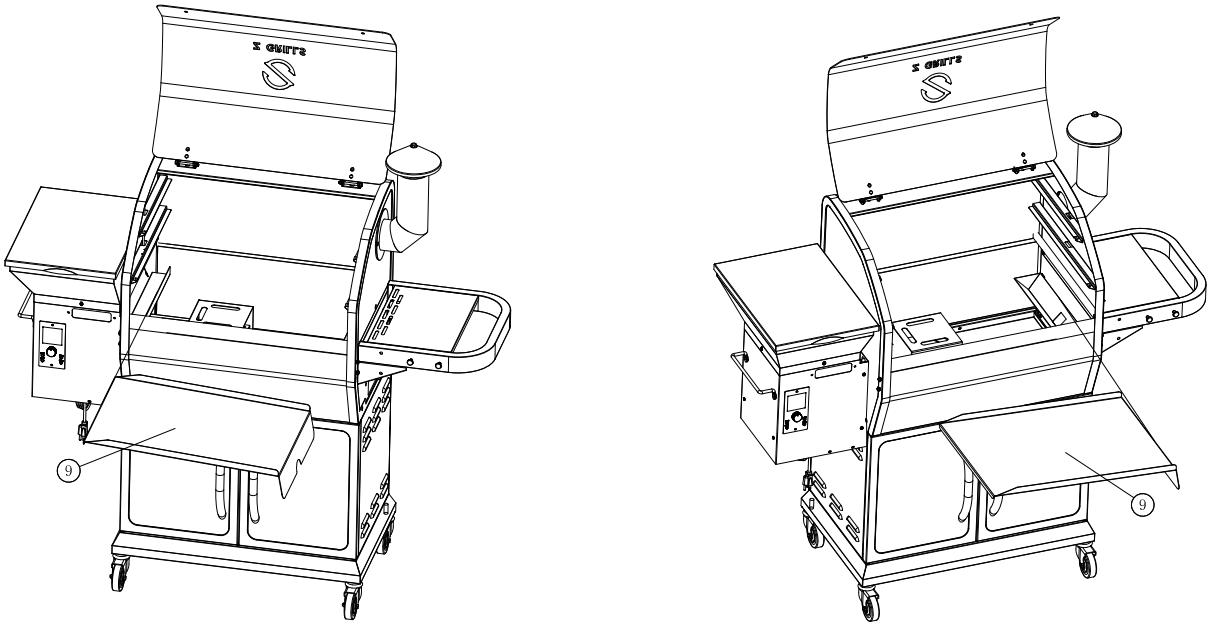

## 11.ATTACHING THE CHAMBER DOOR HANDLE

1.Penetrates Hexagon Bolt (M) through Gasket (F) , Lid,Lid guide(59) and directly into the Lid Handle (2) and tighten. Do not screw too tightly.

2.Use Bolt(J) to insert through Botter Opener(62) into the Side Shelf(11).

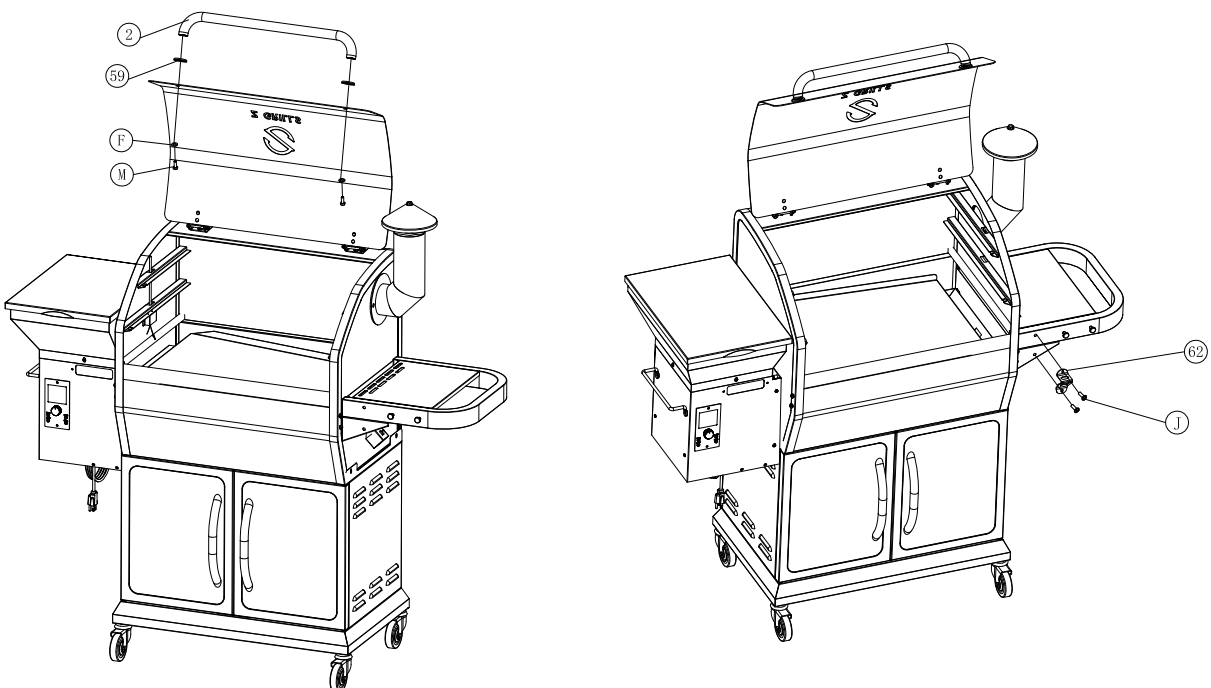

## 12.POSITIONING THE PORCELAIN GRILL AND WARMING RACK

Position the Porcelain Grills (7) inside the cooking area and locate the Warming Rack (6)(5) on the rack support inside the chamber.

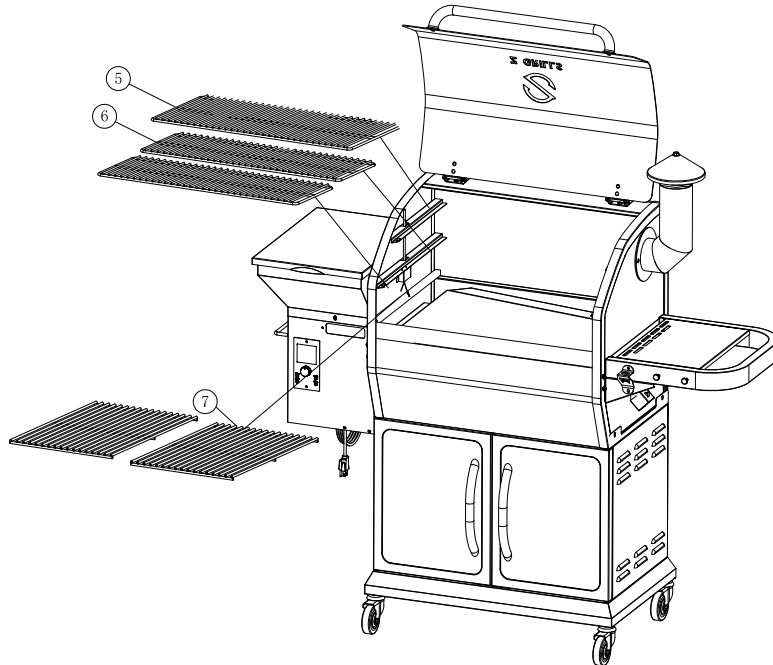

## 13.POSITIONING THE ASH TRAY

- 1.Install the Ash Tray Handle (13) on the Ash Tray (12) with Bolts (A) and Nuts (I).
- 2.Insert the Ash Tray (12) into the Grill Chamber (1).
- 3.Use Bolt(J) to insert through Winding Handle(60) into the Hopper Bottom Assembly(50).

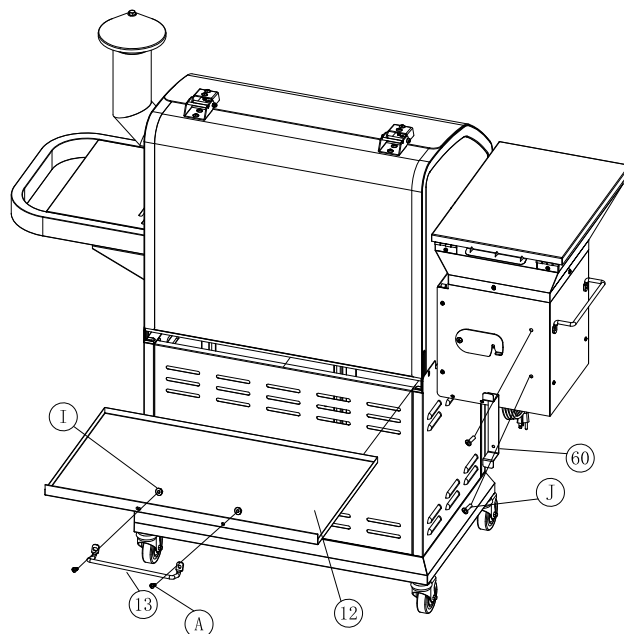

## 14.HANG ON THE GREASE BUCKET

Locate the Grease Drain Tube which is on the right side of the chamber, then hang the Grease Bucket (10) on the hook.

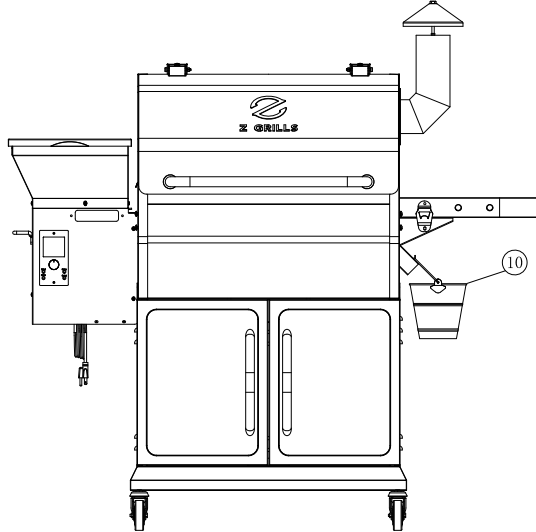

## WiFi Antenna

The grill comes with WiFi antenna that is packed neatly together with the power cable underneath the hopper.

The long lead and magnetic base make it convenient to find the best location for the antenna.

A good location is underneath the hopper, but if the signal is not strong enough, try the top of the hopper lid, or higher up on a nearby wall.

Do not place the antenna on any hot parts of the grill as the base and lead may be damaged.

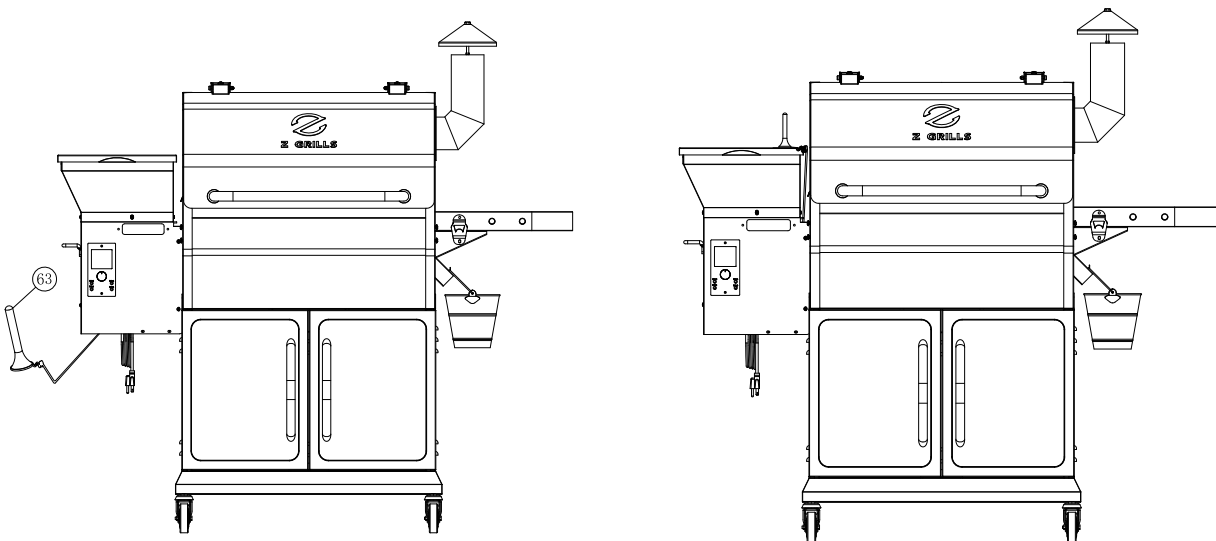

## INITIAL FIRING INSTRUCTIONS

**Please read this manual carefully and follow it step by step before starting your Z Grills for the first time and each time the grill runs out of pellets.**

1. Remove the Porcelain Grills, Warming Rack, Grease Drain Pan and Heat Baffle from the interior of the grill.

2. Open the Pellet Hopper Lid, make sure there are no foreign objects in the Auger and Hopper.

3. Press once control button to turn on your Z Grill and to enter the working state, the default gear is 275F. If you want to adjust the temperature unit, please see the control board instructions.

Please check the following things:

**(WARNING: Please do not touch it!)**

- Confirm the Auger is turning.
- Hold your palm above the Firepot to confirm the fan is blowing air through the Firepot.
- The hotrod will heat up and you should be able to sense the heat coming from it. (It takes approximately 2 minutes.)
- **You should see a temperature number displayed on your LCD DISPLAY. If you see something different displayed it is an ERROR CODE. NOTE: PLEASE SEE TROUBLESHOOTING FOR DETAILS ON ERROR CODES.**

4. Fill the Pellet Hopper with Pellets. Turn on the grill normally. It takes 8 minutes for the Pellets to travel through the tube. When the Pellets start to drop, enter into SHUT DOWN in MENU or Press and Hold for 5 seconds to power off. **Do not unplug the power directly when in use.**

Leave grill until it shuts off automatically.

5. Open the lid, Place components back in place. Then turn the Temperature Dial to highest level (550F), 10 minutes later, when you see whitish-gray smoke coming out of the grill, close the lid and let grill run for 30 minutes at this setting to rid it of anti-rust oil.

**This step must be done before cooking any food.**

Now, you can turn the Temperature Dial to any cooking setting desired.

## SUBSEQUENT START-UP

**ATTENTION:** If the grill fails to light or the fire in the Firepot goes out while cooking, it is vital to follow these steps when sufficient pellets are still in the Pellet Hopper. Failure to follow the steps may cause a hazardous “over-firing” of your grill due to an excess of unburned pellets in the Firepot.

1. Turn OFF the appliance and unplug the Power Cord. After the grill cools down, remove all food, the Porcelain Grills, Grease Drain Pan and the Heat Baffle.
2. Remove all unburned pellets and ash from inside and around the Firepot (See instruction for proper handling and disposal of ash).
3. Plug the Power Cord and turn on the grill. Pellets should fall into the Firepot and the Hot Rod should begin to heat (it will start to turn red).
4. If this step is successful, you will see flames come out of the Firepot. Enter into SHUT DOWN in MENU or Press and Hold for 5 seconds to power off and let it cool down. Next, put components back in place, open the lid and turn on the grill. Wait a few minutes until you see whitish-gray smoke coming out of the grill, then close the lid and turn the Temperature Dial to any cooking setting desired.
5. If this step is not successful, see TROUBLESHOOTING or contact Z GRILLS Technical Support to help diagnose the problem.

## SHUTDOWN CYCLE

- Auger turns off
- Fan continues to run for 10 minutes

After you have finished cooking, turn the Temperature Dial to Shutdown Cycle position. The function of this setting is to leave the Draft Induction Fan running for 10 minutes to burn redundant pellets in the firepot. After the fan runs for 10 minutes, the fan will stop and the controller will power off.

**CAUTION:** The main power switch will shut the power off to the controller and the Temperature Dial Knob switch will cut off power to the grill components only. When servicing the controller or any parts ensure that the power supply is disconnected by unplugging the grill to avoid a shock hazard.

## OPERATING TIPS

1. Like all grills, the actual temperature of this grill and the cooking times will be affected by external temperature, humidity, wind conditions, quality of pellets, etc.
2. It is beneficial to shelter your grill from the wind. This will aid in temperature output, heat retention and heat recovery time when the lid is open.
3. Do not open the lid frequently, it will increase your cooking time. You can open the lid when you want the grill to cool down quickly.
4. Please preheat the grill for 10 minutes before adding food. This will allow your grill to heat up quickly and return to your desired temperature once food is added.
5. Never move your grill while in use.
6. Never put water into the Pellet Hopper or Firepot.
7. **WARNING: NEVER ADD PELLETS TO THE FIREPOT DIRECTLY. IT IS DANGEROUS.** If you run out of pellets and lose your fire while cooking, let the grill cool down and start again with the INITIAL FIRING INSTRUCTIONS.
8. We recommend you cover your Grease Drain Pan with heavy-duty aluminum foil and change it frequently. This is the simplest way to clean your Grease Drain Pan. Failure to clean the Grease Drain Pan, V-shaped Grease Drain and Grease Drain Tube may cause grease fires. If this situation happens, turn the control knob to SHUT DOWN in MENU and keep the lid open until the fire is completely out. AT THE SAME TIME, BE CAREFUL NOT TO BURN YOURSELF. When the grill is completely cool, clean any grease accumulation from the V-shaped Grease Drain and the Grease Drain Pan. Replace the foil on the Grease Drain Pan. Then restart the grill and resume cooking.

# MAINTENANCE & CLEANING

Your Z GRILL requires regular maintenance.

**Make sure your grill is OFF, unplugged and completely cold before performing any maintenance and cleaning.**

## Grease

1. With regular use your grill will accumulate grease on the Flue Lining, the Grease Drain Tube, the V-shaped Grease Drain and the Grease Drain Pan. Always be sure these areas are clean and free of grease and debris. You should check and clean these areas regularly to reduce the risk of fire.

2. It is easier to remove accumulated grease when the grill is still warm (not hot).

**BE CAREFUL NOT TO BURN YOURSELF.** Heat-resistant gloves are recommended.

If too much grease is allowed to build up in the V-shaped Grease Drain or is allowed to plug the Grease Drain Tube, a grease fire could result. It is necessary to clean these areas regularly. You can scarp the grease accumulation from inside the V-shaped Grease Drain and Grease Drain Tube by using a stiff, nonmetallic tool. Much of the loosened grease can be pushed down through the Grease Drain Tube and fall into the Grease Bucket. Wipe up remaining grease residue with paper towels or disposable rags.

## Flue Pipe(Smoke Stack)

Remove the Chimney Cap Assembly, clean it with warm soapy water. Scrape the creosote and grease accumulation from inside of the vertical and horizontal sections of the Flue Pipe by using a stiff, nonmetallic tool such as a wooden paint stir stick. Once the creosote and grease residue has been loosened from the Flue Pipe Lining, much of it can be cleaned with paper towels or disposable rags. Do not spray water or other liquid cleaners onto the inside of the grill.

## Outside surfaces

1. Use warm soapy water to wipe away grease. Do not use oven cleaner, abrasive cleansers or abrasive cleaning pads on the outside grill surfaces.

2. It is highly recommended that you use Z GRILLS Cover to protect your grill .

3. You can use a high-quality car wax on the outside surfaces of your grill to protect it's finish.

## Internal component

1. To clean the Porcelain-coated Grill Grates we recommend using a long-handled cleaning brush designed for Porcelain-coated Grates.

2. It is recommended that you clean your Grill Grates after each use.

3. Clean the inner RTD temperature probe after each use.

## **Ash**

Clean the ash from the Ash Tray of the grill periodically. If excessive ash is in the firepot, it may cause the fire to go out. This is especially true in the SMOKE setting. A shop vac is an excellent tool to use for removing the ash. **WARNING: MAKE SURE THE GRILL FIRE IS OUT, THE UNIT IS OFF, UNPLUGGED AND COLD BEFORE ATTEMPTING TO CLEAN ASH FROM THE GRILL.**



## TROUBLESHOOTING

**CAUTION:** Make sure the grill is completely cool and unplugged before you do any inspection, cleaning, maintenance or service work.

Problem	Potential Cause	Solution
Grill does not work properly	Power	Make sure the power cord is plugged in. Verify there is power at the electrical outlet.
	Fuse	Remove the digital control, check the fuse on the back. Replace the fuse if blown.
	Hot Rod	If both of the Draft Inducer Fan and the Auger Driver Motor are operating, the Hot Rod needs to be replaced. If one or both are not operating, please contact customer support.
	Wires & Connections	Check the wires and connectors to make sure they are fastened securely and not damaged. Contact customer support if you need help.
	Auger Drive Motor	Locate the small fan motor blade on the back of the auger drive motor. Turn unit on. If the fan does not turn on then the Auger Drive Motor needs to be replaced.
Fire goes out	Too much ash	Clean the ash. Refer to MAINTENANCE & CLEANING.
How to start	Control Knob	Start your grill with the lid open. After 5 minutes, close the lid and turn to any temperature setting desired. Read the INITIAL FIRING INSTRUCTIONS carefully.

Unexpected grill temperature is displayed	External Factor	Grill temperature is influenced by environmental factors such as high temperature, wind and direct sun. Place unit in shaded area. Open the lid to reduce inside temperature. After start your grill in 40 minutes, the grill will reach your desired temperature.
Excess or discolored smoke	Pellets	Replace moist pellets with fresh dry pellets.
Get your new parts	Contact Z GRILLS Customer Service or your Z GRILLS dealer to place an order	When contacting customer support please have the following information available: Your authorized Z Grills dealer, your name, phone number, address, your Z Grill serial number and part identification number. Your part number is listed on the COMPONENT LIST.

**Alarm mode**

Entry alarm: fan is on, the ignition rod is off, and the feeding motor is off

**ERROR 1 TEMP SENSOR**

RTD temperature sensor alarm, RTD open, damaged, or poor contact.

**ERROR 2 HIGH TEMP**

High temperature alarm. Alarm when the temperature exceeds 650F(343℃ ) warning value.

**ERROR 3 LOW TEMP**

Low temperature alarm, Low temperature at 135F ( 57℃ ) for 6 minutes and alarm.

**ERROR 4 NO FIRE**

Ignition failure. Five attempts were unsuccessful.The ignition rod is started 5 times and still does not heat up (equivalent to no particle combustion).

**ERROR 5 AUGER ERR**

Auger motor alarm, auger motor is not properly connected, damaged, open circuit or poor contact.

**ERROR 6 FAN ERR**

The fan alarm indicates that the fan is improperly connected, damaged, open, or in poor contact.

**ERROR 7 IGNTIOR ERR**

Ignition rod alarm, ignition rod is not properly connected, damaged, open or poor contact.

**WARNING: DO NOT TURN OFF THE SWITCH WHILE THE FAN IS STILL WORKING ON THE SHUT DOWN CYCLE, THE GRILL WILL AUTOMATICALLY SHUT OFF WHEN THE CYCLE IS DONE. INTERRUPTION OF THE SHUT DOWN CYCLE COULD RESULT IN A FIRE IN THE HOPPER CHAMBER.**

# DIGITAL THERMOSTAT CONTROL WIRING DIAGRAM

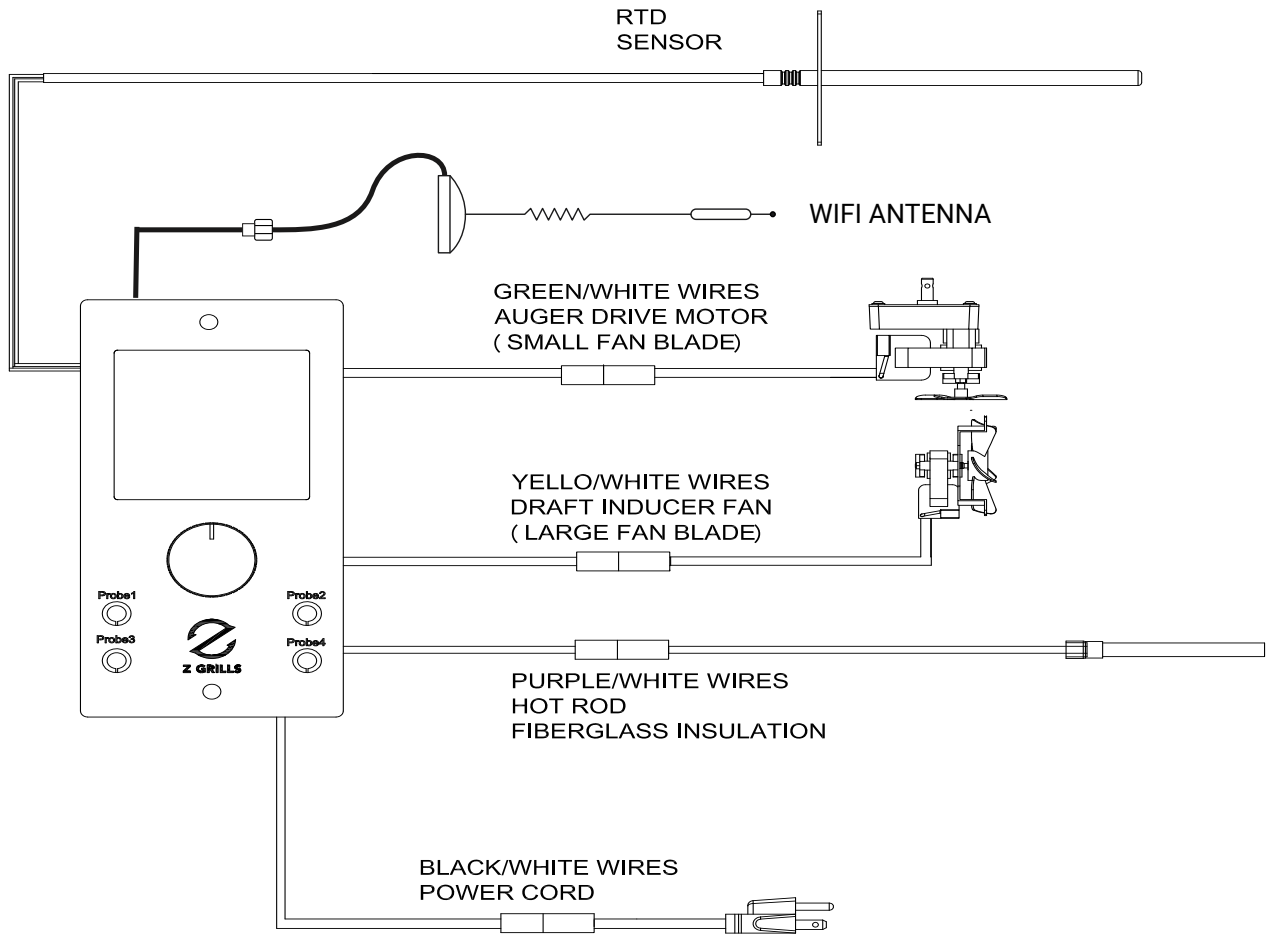

## Usage of the Meat Probe

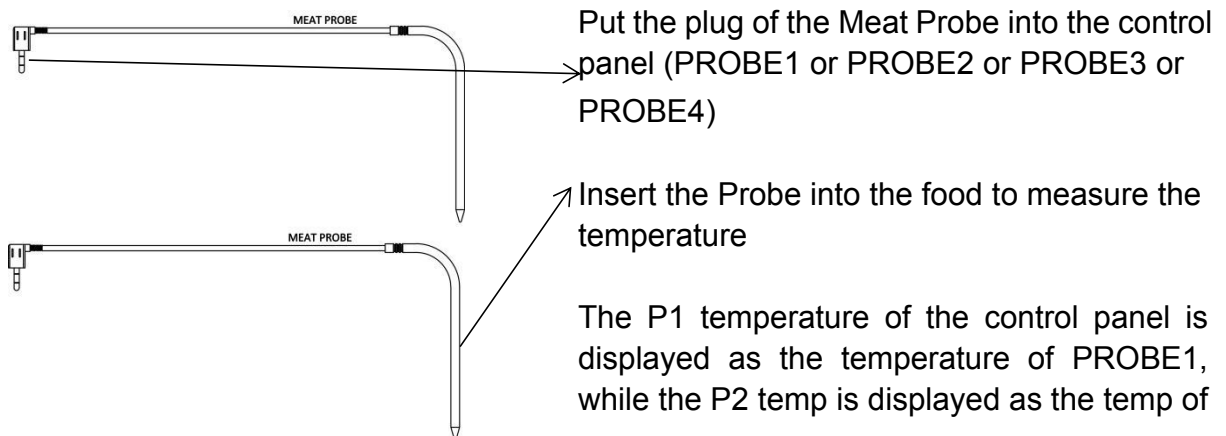

The P1 temperature of the control panel is displayed as the temperature of PROBE1, while the P2 temp is displayed as the temp of

PROBE2, the P3 temp is displayed as the temp of PROBE3, the P4 temp is displayed as the temp of PROBE4.

# CONTROL BOARD

Press once the Control knob to turn on the grill, the screen will display for 1 second, and then display the code information to enter the working state, the default gear is 275F.

Press and hold for 2 seconds to enter the Menu screen. Press and Hold for 5 seconds to power off.

## Menu: SHUT DOWN

### TEMP UNITS :Celsius(°C) or Fahrenheit(°F)

Press and hold for 2 seconds to enter the menu screen, rotate to the right to the temperature unit adjustment screen, select °C or°F, and press the knob to confirm.

**EXIT:** return to the current working interface .

## Temperature

1:Actual temperature from inside.

2:Desired target temperature

The product in normal operation, press once the control knob, the upper right corner temperature gear value will flash, turn the knob left and right to the target temperature, the temperature range of 160F-550F, press once the knob to confirm the target temperature, the lower right corner will display the desired target temperature.

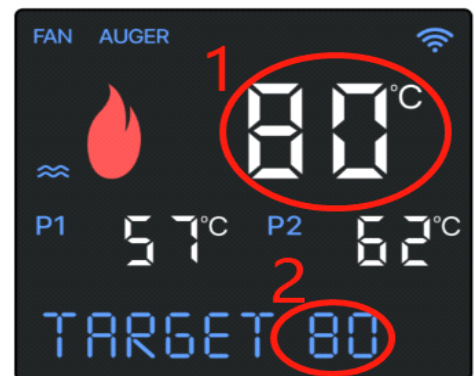
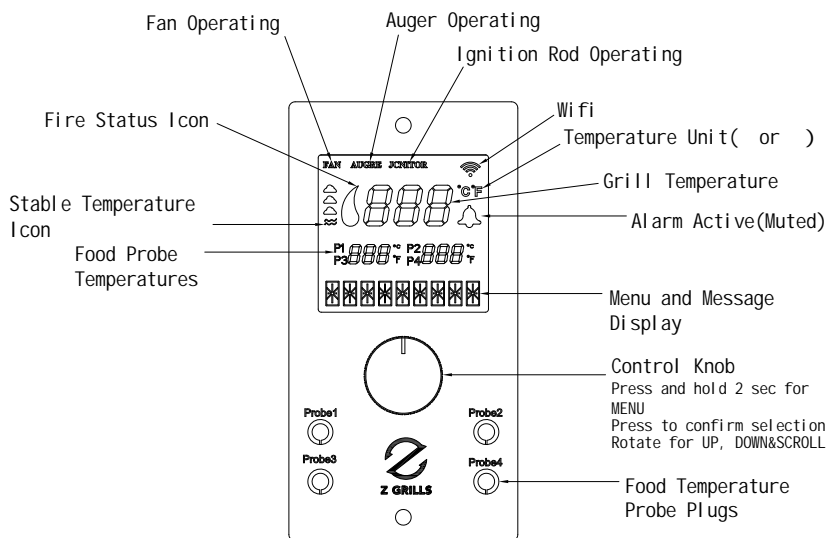

**Note:** When the temperature value enters the MENU interface in the flash, the MENU content cannot be adjusted.

## Shutdown method:

- Press and hold for 2 seconds to enter the menu screen and tap to shut down.
- Press and Hold for 5 seconds to power off.

## Shutdown working mode:

Fan delay work, countdown 10 minutes, at this time LCD display shutdown countdown and fan work, other content will not be displayed; After the timing is complete, the screen does not display, indicating that all power off.

# **Z GRILLS SUPPORT**

Thank you for purchasing a Z GRILL!

If you have any question, please contact customer support or your Z GRILL dealer.

Z GRILLS, INC. offers the best technical and sales support in the industry.

When calling customer please be prepared to provide the following information:

1. Dealer's name and date of purchase
2. Purchaser's name, phone number and address
3. Z GRILLS model number, serial number and part identification numbers
4. Please be prepared to describe your problem accurately so we can help you resolve your issue
5. Providing pictures or videos is beneficial

## **Z GRILLS CUSTOMER SERVICE**

**MON TO FRI, 8:00 A.M. - 5:00 P.M. PACIFIC STANDARD TIME**

**SERVICE CONTACT: 1-833-947-4557/1-833-ZGRILLS**

**EMAIL: [support@zgrills.com](mailto:support@zgrills.com)**

**WEBSITE: [www.zgrills.com](http://www.zgrills.com)**

# **Z GRILLS**

## **3-YEAR LIMITED WARRANTY**

Z GRILLS, Inc. provides a 3-year warranty from the date of purchase by the original owner. This warranty applies to defects in all materials and workmanship. During the warranty period, Z GRILLS, Inc. will at its option repair or replace defective parts or units.

This limited warranty does not apply to paint, firepot, grill cover or damage caused from corrosion. Z Grills shall not be liable for transportation charges, labor costs or export duties.

Z GRILLS, Inc. takes every precaution to utilize materials that retard rust including the use of high-temperature paint where advisable. Even with these safeguards, the protective coating can be compromised by various substances and conditions beyond Z Grills' control. Humid environment, high temperature, chlorine, insecticide, salt and disinfectant are some of the substances that can affect paint and metal coatings. For these reasons, the limited warranties do not cover rust or oxidization, unless there is loss of structural integrity on the grill components.

Z GRILLS, Inc. shall not be liable if you install, operate, clean or maintain your grill without following the owners' manual instructions. Misuse, abuse, alteration and natural disasters are not included in this warranty.