



2021-22 Ford Bronco
RTR Tire Carrier Spacer
Part number 14021.0013.14.A

Components Included

- | | | |
|----|--------------------------|---|
| 1. | Tire Carrier Spacer | 1 |
| 2. | M8 Socket Head Cap Screw | 8 |
| 3. | Instructions | 1 |

RTR advises the use of Loctite® Threadlocker Blue 242, or equivalent, on all threaded fasteners during assembly of this product.

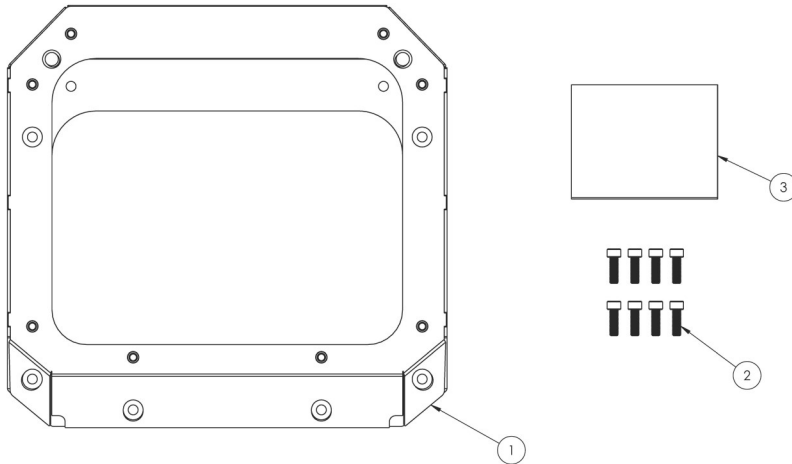

1. With the vehicle parked on a level surface remove the three lug nuts, spare tire and set them aside.

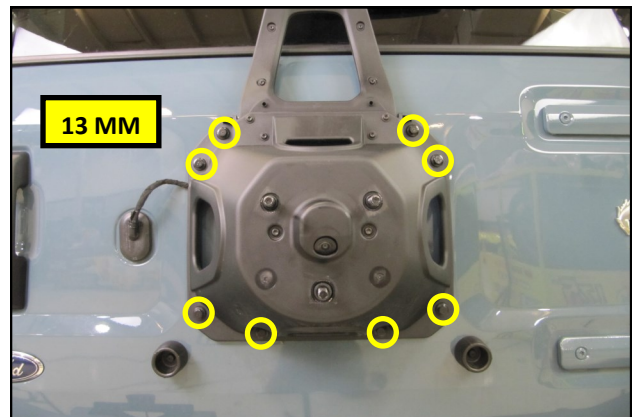

2. Remove the eight flange bolts securing the OEM tire carrier to the vehicle and set them aside. Retain this hardware for later use.

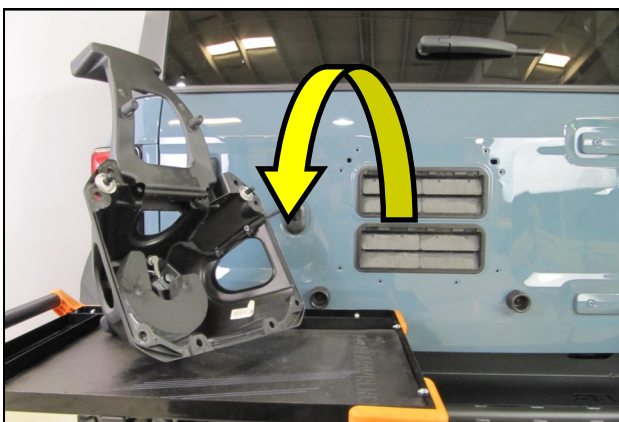

3. Remove the tire carrier from the vehicle and set it onto a tool cart or equivalent.

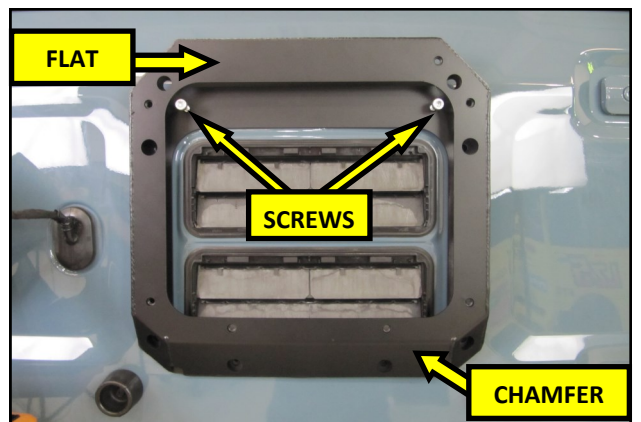

4. Carefully place the RTR Spacer onto the tailgate as shown, with the flat side at the top and the chamfered side at the bottom. Thread 2 of the supplied M8 Socket Head Cap Screws into the top 2 holes in the tailgate, as shown, to hold it in place.

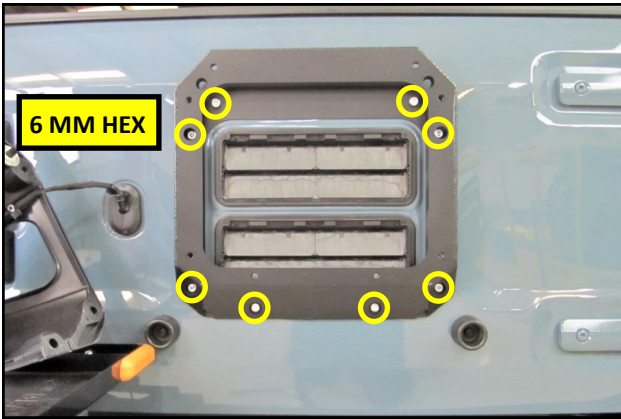

5. Thread the six remaining Cap Screws through Spacer and into the vehicle. Torque Screws in alternating pattern to 30 lb. ft.

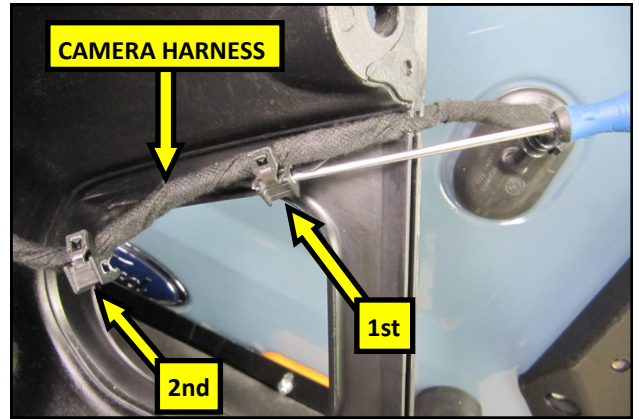

6. Using a pocket screwdriver, carefully pry the first and second harness anchors off of the tire carrier.

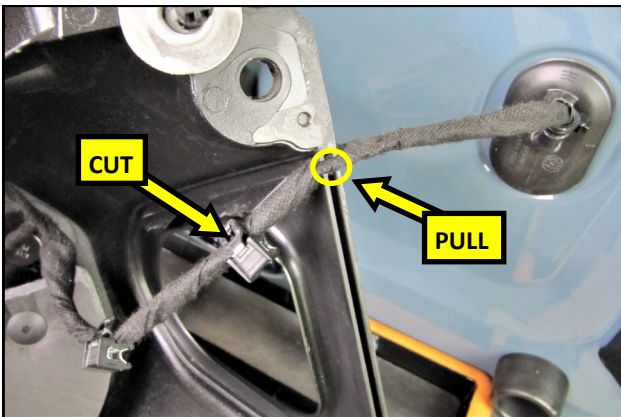

7. Using diagonal cutters, carefully cut the first harness anchor and remove it. Unclip the harness from the edge of the tire carrier.

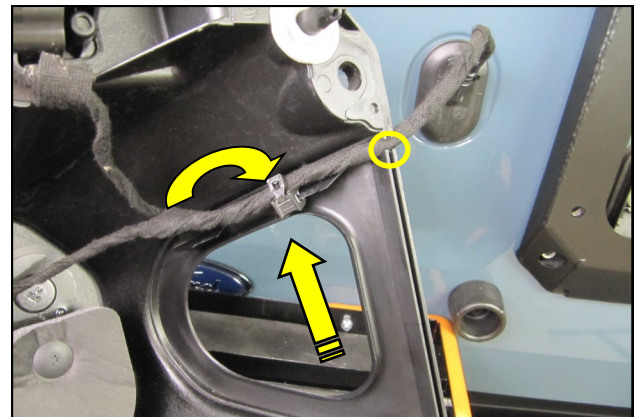

8. Relocate the second anchor to the position of the first anchor on the carrier and clip the harness back in as shown.

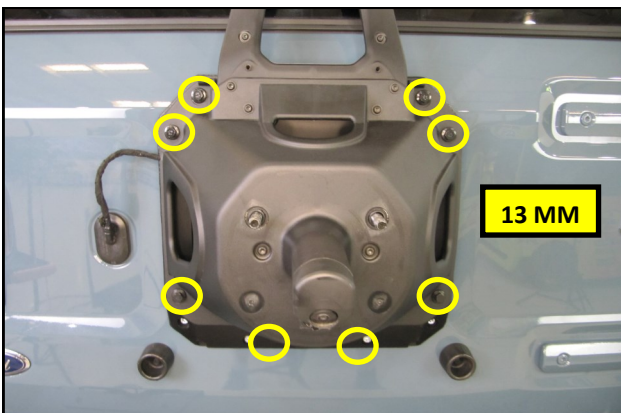

9. Slide the tire carrier onto the RTR Spacer and secure it using the hardware removed in step 2. Torque the flange bolts in an alternating pattern to 30 lb. ft.



10. Slide the spare tire onto the carrier and torque the lug nuts to 98 lb. ft.