



Part number 1898-7020-01(402317)

2018 Ford Mustang

RTR Rocker Splitters

Component Identification

1.	Rocker Splitter, Left	1
2.	Rocker Splitter, Right	1
3.	Plastic Rivets	24
4.	Adhesion Promoter (not shown)	1

NOTE: In addition to common hand tools, this installation requires the use of a T20 torx bit and a hand drill with a 1/4" drill bit.

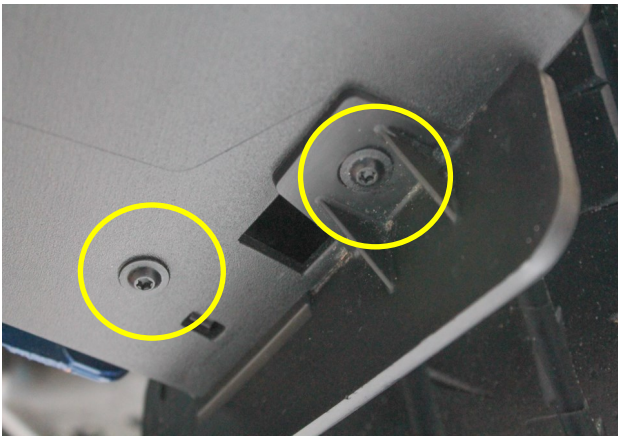
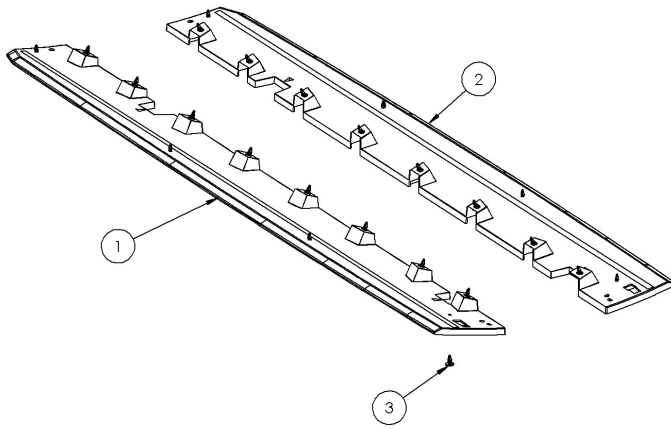

1. Using a T20 Torx bit, remove two Torx screws from the bottom of the splash shield.

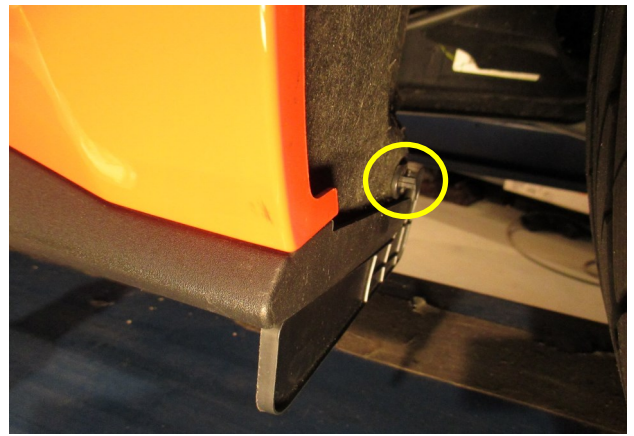

2. Remove one plastic rivet from the inside of the wheel well and remove the splash shield.

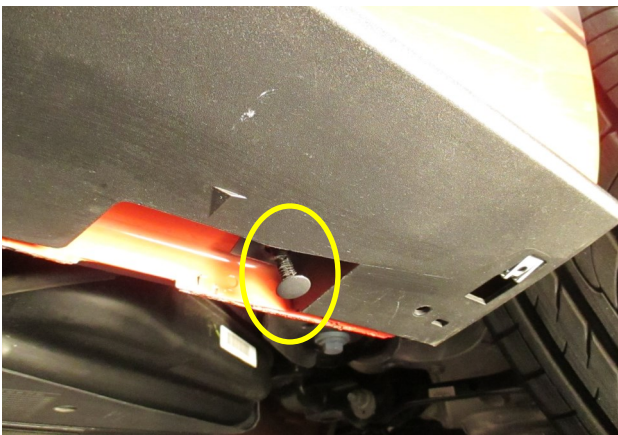

3. Remove the eight plastic clips securing the OEM rocker panel. These will not be reused.



4. Using a mild soap and water solution, clean OEM plastic of any and all debris.

When completely dry, prepare the surface with the supplied Adhesion Promoter.



5. Peel the ends of the red plastic backing off of the Adhesive Strips on the RTR Rocker Splitter and lift into place on the vehicle.

NOTE: Only peel off enough to leave a small strip accessible, as shown.



6. Install the eight provided Plastic Rivets into the factory hole locations. Once the Plastic Rivets are installed, peel the remaining red plastic backing off and firmly press the RTR Rocker Splitter against the OEM rocker to adhere.

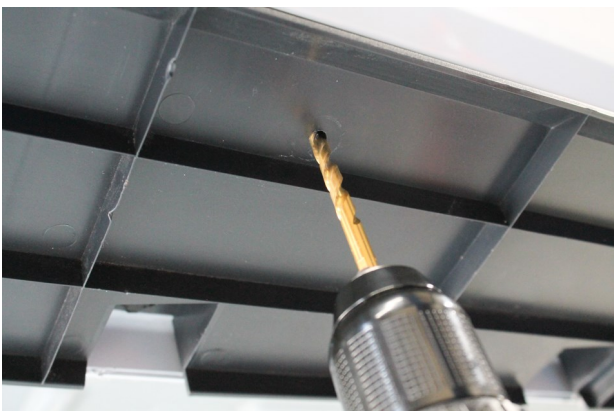

7. Using the holes in the RTR Rocker Splitter as a guide, drill four 1/4" holes in the OEM rocker panel.

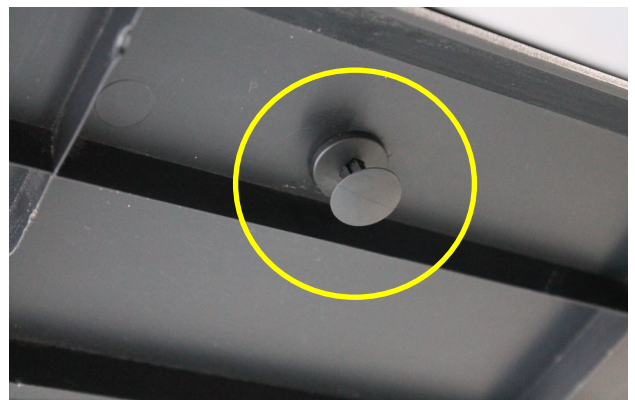

8. Install the four provided Plastic Rivets in the holes drilled in previous step to complete installation.

****Repeat on opposite side****