

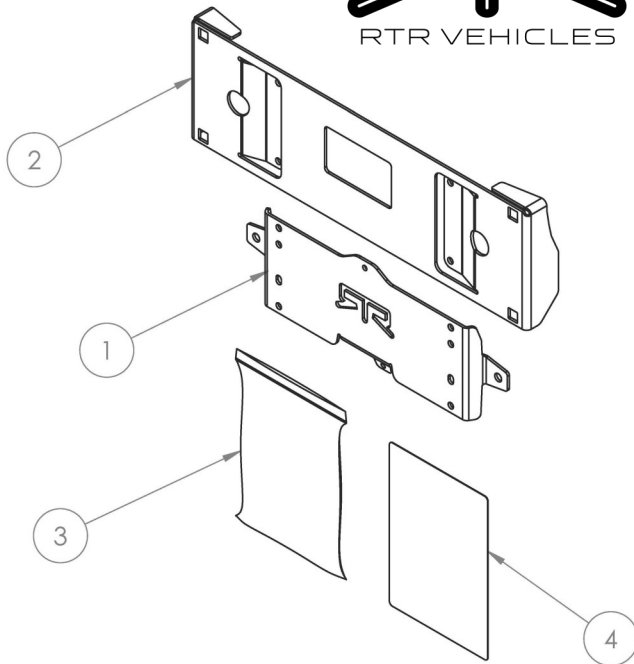

**2024 Ford Mustang
Plate Mount for RTR Grille**
For Italian registration plates-
(340 mm x 110 mm)
Part Number 11011.0014.12.A



Components Included

1.	Base Plate	1
2.	Plate Mount	1
3.	Hardware Pack	1
4.	Instruction Scan Card	1



1. Place the bumper cover with the RTR Grille installed face down onto a padded work surface.

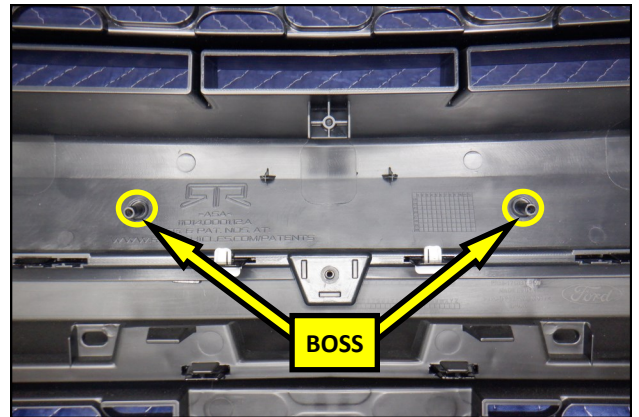

2. Locate the two Screw Bosses in the center of the RTR Grille.

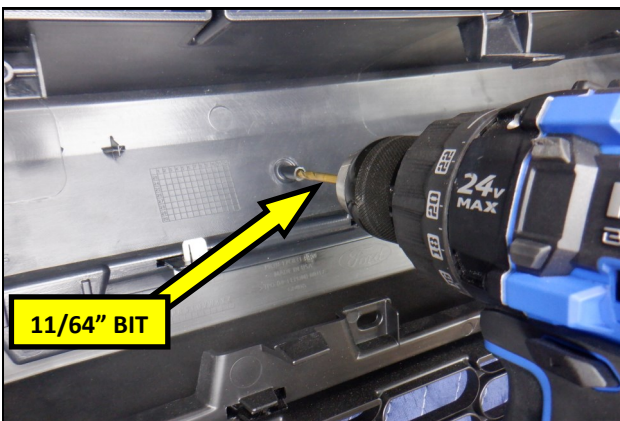

3. Using the Screw Bosses as guides, drill through the RTR Grille using an 11/64" bit.

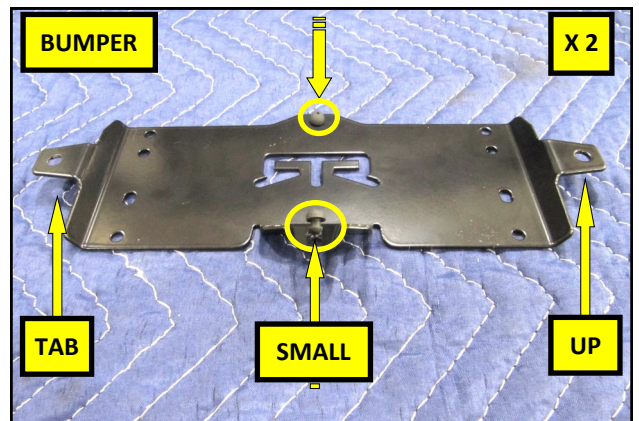

4. Place the Base Plate on a padded work surface as shown, with the mounting tabs raised. Carefully insert the Rubber Bumpers into the Mount, small side first.

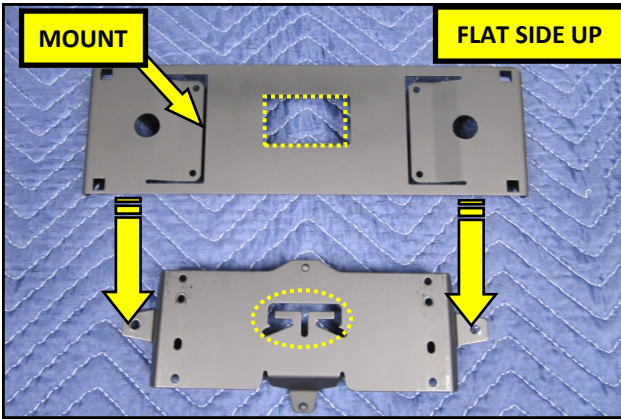

5. Turn the Base Plate over, with the tabs down, and place the Plate mount on top of it, flat side up. When properly placed, the RTR logo will be fully visible in the window in the mount.

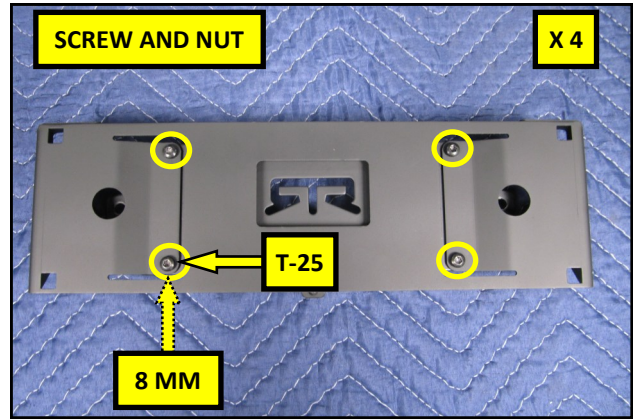

6. Using a T-25 TORX® driver and a 8 mm wrench, secure the Plate mount to the Base Plate with the 5 mm Screws and Lock Nuts.

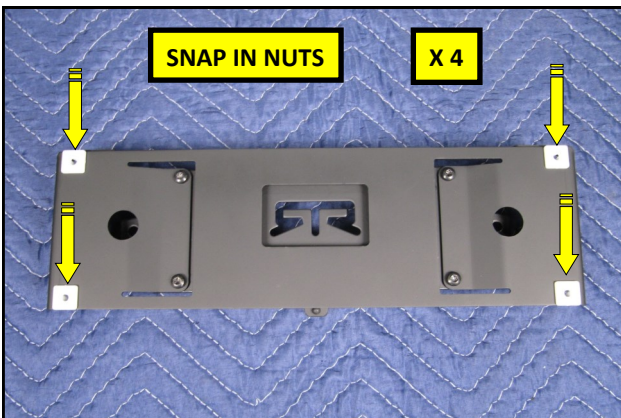

7. Insert the plastic Snap-In Nuts into the Plate Mount.

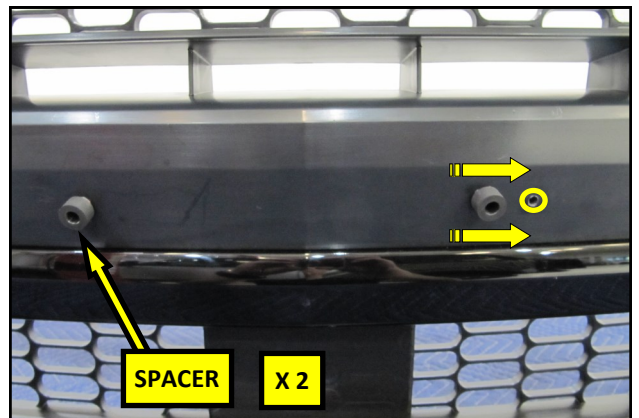

6. Place the rubber Spacers over the holes in the front of the bumper cover made in step 3 and align the holes.

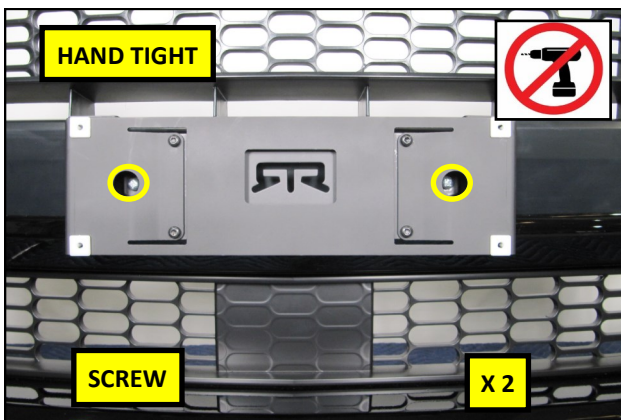

8. Using the Large Phillips Head Screws, secure the mount to the bumper cover, as shown. Tighten the screws until the Bumpers from step 4 come in contact with the bumper cover. Tighten by hand to avoid damaging the cover.

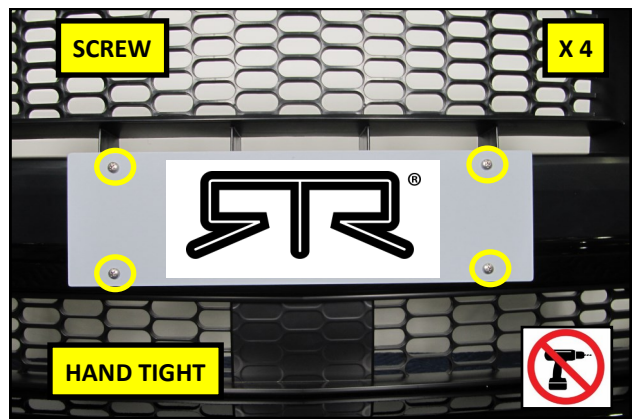

9. Using the 4 short Phillips head screws, secure the plate to the Mount as shown. Tighten by hand to avoid damaging the cover.
Continue on to step 26 in the Upper Grille install Manual.