

CLUTCH KIT

2018-2019 Textron/Arctic Cat Wildcat XX
Installation Guide

PARTS LIST



- | | |
|----------------------------|------------------|
| 1 HELIX | 3 WEIGHT ARMS |
| 1 SECONDARY SPRING (BROWN) | 9 MAGNETS (3/8") |

PLEASE READ ALL DIRECTIONS BEFORE STARTING INSTALLATION



11-DCK1

ARCTIC CAT

ADJUSTMENT SETTINGS

INTENDED USE	ELEVATION	MAGNETS	TOTAL WEIGHT	SECONDARY SPRING
Trail Std 30" tires	0-3000 feet above sea level	2	60 grams	Brown
Trail 32" tires	0-3000 feet above sea level	1	58 grams	Brown

RECOMMENDED SETTINGS FOR HIGH ELEVATION

Subtract 1 magnet from each arm	3000-6000 feet
Subtract 2 magnets from each arm	+6000 feet

CLUTCH ARM ADJUSTMENT

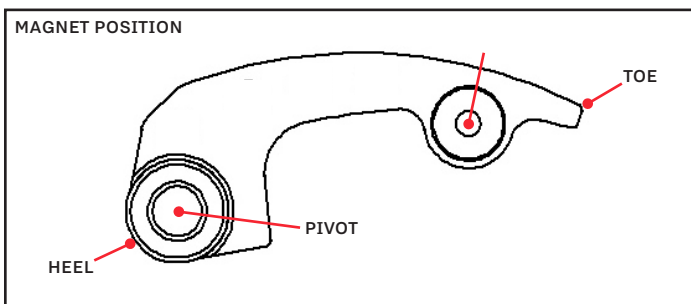

LOAD MAGNETS STARTING AT HEEL POSITION #1

Load magnets per the table above. Make sure each clutch arm is loaded with the same amount of weight.

- More weight near the heel increase acceleration.
- More weight near the toe decreases RPM.
- One magnet change per arm will alter RPM by approximately 150 RPM.

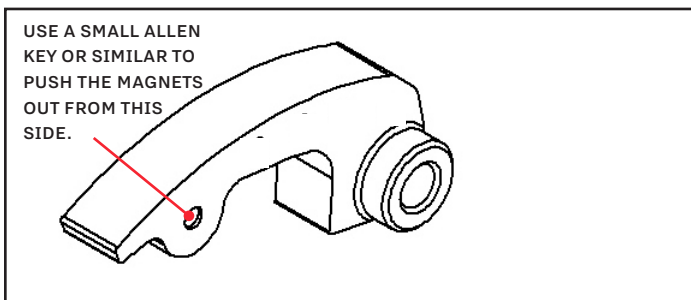

TO REMOVE MAGNETS

Our settings are a general baseline. Many things can effect clutch setup, including:

- Tire brand and size
- State of clutch wear
- Drive-belt condition
- Engine power output
- Environment conditions

INSTALLATION INSTRUCTIONS

IT IS RECOMMENDED TO HAVE AN AUTHORIZED TEXTRON/ARCTIC CAT TECHNICIAN INSTALL THE CLUTCH KIT, AS SPECIAL TOOLS ARE NEEDED TO COMPLETE THE INSTALLATION (SEE BELOW). CONSULT THE FACTORY SERVICE MANUAL FOR TORQUE SPECIFICATIONS AND OTHER IMPORTANT DETAILS. INSPECT AND CLEAN ALL STOCK PARTS BEFORE RE-ASSEMBLY. REPLACE STOCK PARTS THAT ARE DAMAGED OR WORN.

Remove the CVT cover.
Remove the drive belt.
Remove the primary and secondary clutch assemblies.

Remove the plastic cooling plate from the primary clutch assembly.

Compress the primary assembly with a spring compression tool.

Loosen the pressure plate.
Release the spring pressure.
Remove the stock weight arms.



PRIMARY ASSEMBLY

Load the new weight arms with magnets as recommended on page 2.
Install the new weight arms into the primary clutch assembly.

Compress the spring.
Secure the pressure plate.
Loosen the spring compression tool.

Reinstall the plastic cooling plate.



WEIGHT ARM

Compress the secondary clutch assembly.
Loosen the helix.
Release the spring pressure.

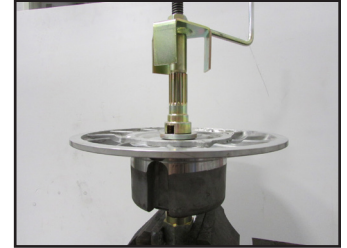

SECONDARY ASSEMBLY

Set the new secondary spring and helix into place.
Compress the spring.
Secure the helix in place.
Loosen the spring compression tool.



SECONDARY ASSEMBLY

Reinstall the primary and secondary clutch assemblies.
Reinstall the drive belt.
Reinstall the CVT cover.

TUNING NOTES

For best performance your RPM when checked at 50mph should be 9100rpm. This should be checked on a surface that offers good traction and tested with normal load in the vehicle. Adjustments to overall weight of each clutch arm may be necessary to achieve this RPM target.

If you were to test on the street and then ride in the sand or mud it is not uncommon to see a loss of 300-400rpm if using paddle tires.

SPECIAL TOOLS NEEDED FOR INSTALLATION

- BELT REMOVAL TOOL (IN TOOL KIT)
- PRIMARY PULLER (0744-062)
- PRIMARY SPANNER WRENCH (0644-136)
- PRIMARY BOLT TOOL (0644-281)
- CLUTCH SPRING COMPRESSOR TOOL (0644-444)



PUSH THE LIMIT

2191 MENDENHALL DRIVE, NORTH LAS VEGAS, NV 89081 - 800-992-4993 - DYNOJET.COM

© 2019 DYNOJET RESEARCH ALL RIGHTS RESERVED