

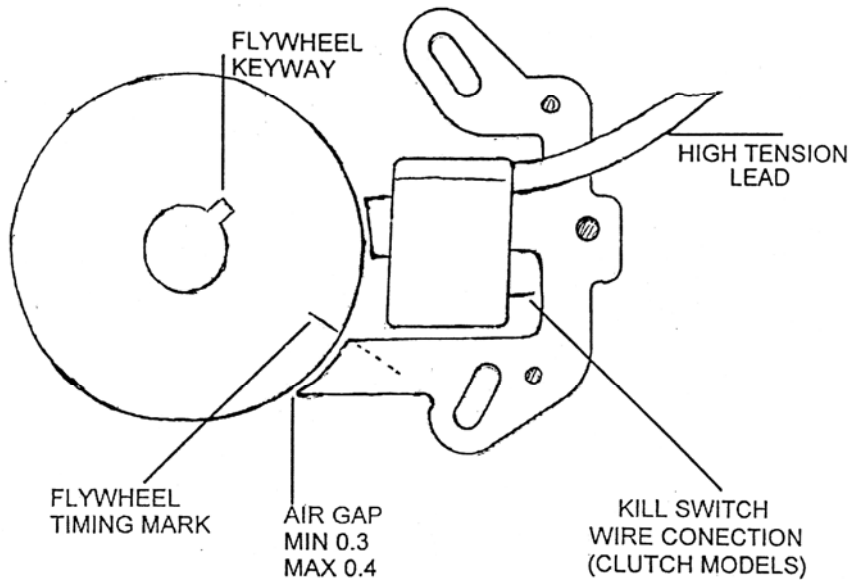

PRD / OPPAMA IGNITION COIL

- 1/ INSERT DIAL GAUGE AND SET TO T.D.C
- 2/ TURN FLYWHEEL CLOCKWISE UNTIL MARK LINES UP WITH LAMINATION
- 3/ CHECK TIMING ON DIAL INDICATOR
- 4/ ADJUST TIMEING BY MOVING COIL UP OR DOWN

NOTE: IT IS RECOMMENDED TO SET TIMING ON PRD ENGINES AT 2.2 B.T.D.C



(THIS IGNITION DOES NOT REQUIRE AN EXTERNAL MODULE)
IMPORTED & DISTRIBUTED BY ST GEORGE KART CENTRE P/L

PRD / OPPAMA IGNITION COIL

- 1/ INSERT DIAL GAUGE AND SET TO T.D.C
- 2/ TURN FLYWHEEL CLOCKWISE UNTIL MARK LINES UP WITH LAMINATION
- 3/ CHECK TIMING ON DIAL INDICATOR
- 4/ ADJUST TIMEING BY MOVING COIL UP OR DOWN

NOTE: IT IS RECOMMENDED TO SET TIMING ON PRD ENGINES AT 2.2 B.T.D.C

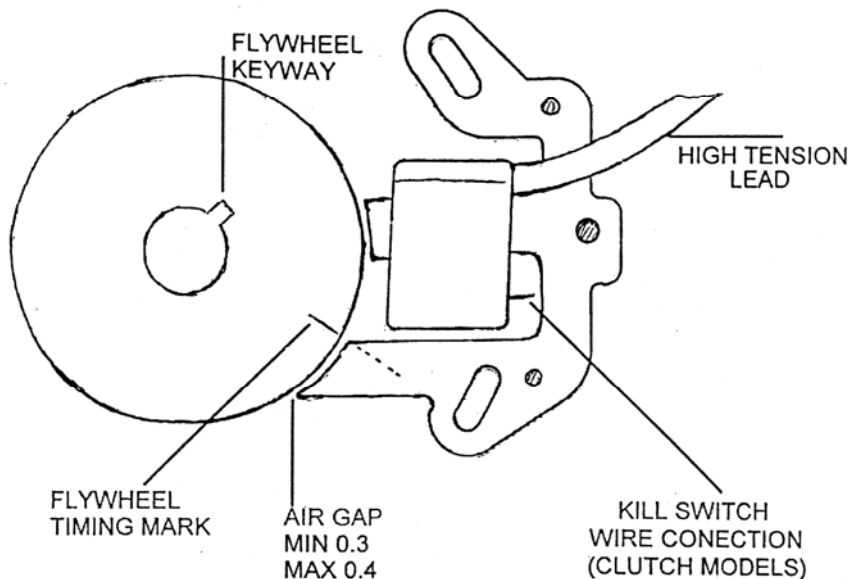

(THIS IGNITION DOES NOT REQUIRE AN EXTERNAL MODULE)
IMPORTED & DISTRIBUTED BY ST GEORGE KART CENTRE P/L