

### FIG 500ST HIGH LIFT SAFETY VALVE

#### FEATURES & BENEFITS

The NABIC Fig 500ST has been designed for applications where the properties of Stainless steel are required for the service fluid being used, but the working environment does not necessitate a full stainless steel valve. It can be supplied with a test lever or as a sealed dome version. Designed and tested to BS EN ISO 4126-1.

- Size Range: DN15 - DN65
- Diaphragm protected working parts
- Resilient PTFE design with high degree of seat tightness
- Stainless steel wetted parts with PTFE to metal seating
- Easy inspection and cleaning
- Pressure setting locked and sealed
- Padlock available (complies with M&E3)
- Available with Viton seat design
- Available with hygienic clamp fitting to BS 4825

#### PRESSURE RATINGS & TEMPERATURE RANGE

MIN - MAX SET PRESSURE (bar)	MIN - MAX TEMPERATURE (°C)
0.4 to 12.5	-20 to 195

#### DIMENSIONS

SIZE DN	Rp BSP Outlet	A (mm)	B (mm)	C (mm)	D (mm)
15	3/4"	34	46	141	50.5
20	1"	39	54	159	50.5
25	1 1/4"	46	63	183	50.5
32	1 1/2"	54	68	228	64
40	2"	64	81	271	64
50	2 1/2"	76	95	315	77.5
65	3"	90	110	380	91

#### PART NAME & MATERIALS

ITEM NO.	PART NAME	MATERIAL
1	Thrust Washer	Brass, BS EN 12164 CW609N
2	Grubscrew	Steel
3	Test Lever	Brass, BS EN 1982 CC754S
4	Spring	Chrome Vanadium Alloy Steel, BS 2803 735 A50 HS (Stainless Steel, BS 2056 302S26 Opt)
5	Label	Yellow kapton
6	Spring Cover	Bronze, BS EN 1982 CC491K
7	Piston	Brass, BS EN 12164 CW609N
8	Diaphragm	Silicon Rubber
9	Seat Seal Holder	Bronze, BS EN 1982 CC491K / Brass BS EN 12164 CW602N (DZR)
10	Seat Seal	PTFE (Viton Opt)
11	Starlock Washer	Stainless Steel
12	Body	Bronze, BS EN 1982 CC491K
13	Lever Pin	Steel
14	Lead Seal	Lead
15	Adjusting Screw	Brass, BS EN 12164 CW609N
16	Spring Plate	Brass, BS EN 12164 CW609N
17	Spindle	Brass, BS EN 12164 CW721R
18	Seat Seal Retaining Plate	Bronze, BS EN 1982 CC491K / Brass BS EN 12164 CW602N (DZR)
19	O-Ring	Viton
20	Seat Adaptor	Stainless Steel, BS 970 316S11



#### MEDIUM

Hot water, steam, air. All other fluids to be checked with Technical Department.

#### PIPE CONNECTIONS

Hygienic clamp fitting inlet connection to BS 4825. Threaded female outlet connections Rp (BSP) to BS EN 10226-1.

#### PRODUCT TESTING

All valves are shell and seat tested (to confirm set pressure) before leaving the factory and all valves are supplied pre-set with a tamper proof seal. Pressure Test Certificate and Letters of Conformity available on request.

#### DIMENSIONAL DRAWING

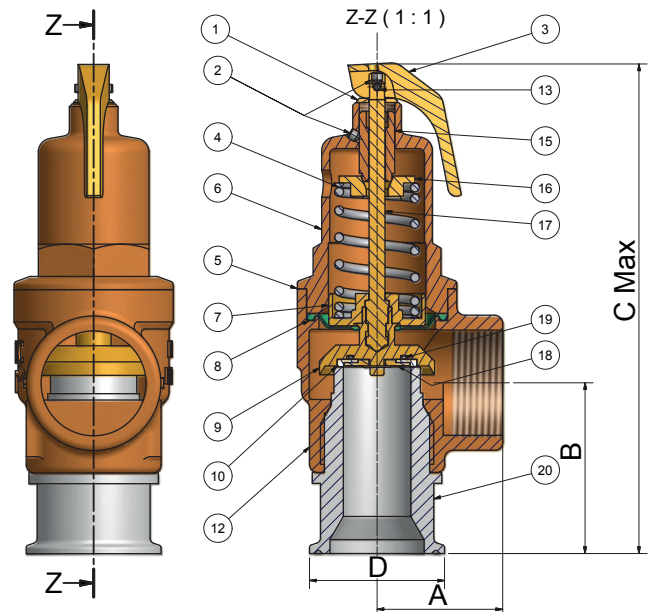

#### APPROVALS



FM00311 ISO 9001



ISO 14001 Reg No. EMS 78657



Pressure Equipment Directive  
PED 97/23/EC and  
Article 13 of 2014/68/EU



### DISCHARGE CAPABILITIES

The discharge capacity of a safety valve must be equal to or greater than the output of the boiler or system it is protecting. To ensure that the correct method of sizing is used, reference should be made to the relevant BS specification for the design of the boiler or system. Fig 500ST capacities are tabulated below to assist selection.

AIR CAPACITY - 10% OVERPRESSURE (BS EN 4126-1)							
SET PRESSURE BAR	std. litres/sec (Kdr=0.479)						
	DN15	DN20	DN25	DN32	DN40	DN50	DN65
1.0	34	61	95	156	244	381	644
2.0	52	93	145	238	372	581	982
3.0	70	125	195	320	500	780	1319
4.0	88	157	245	401	628	980	1656
6.0	124	221	345	565	883	1379	2331
8.0	160	284	445	728	1139	1778	3006
10.0	196	348	545	892	1394	2178	3681
12.5	241	428	670	1096	1714	2677	4524

To convert to ft<sup>3</sup>/min multiply by 2.1.

STEAM - 10% OVERPRESSURE (BS 6759)							
SET PRESSURE BAR	kg/hr (Kdr=0.479)						
	*DN15	DN20	DN25	DN32	DN40	DN50	DN65
1.0	93	166	259	425	664	1037	1752
2.0	142	253	395	647	1011	1580	2670
3.0	191	340	531	870	1359	2123	3588
4.0	240	427	667	1092	1706	2666	4506
6.0	338	600	938	1537	2402	3752	6341
8.0	436	774	1210	1981	3098	4838	8177
10.0	534	948	1482	2426	3793	5924	10013
12.5	657	1165	1821	2982	4663	7281	12307

The minimum bore size permitted by BS specifications for steam and hot water boilers is 20mm.

Capacities given for the smaller sizes in the tables, are for applications outside the scope of these standards.

WATER CAPACITY - 10% OVERPRESSURE (BS EN 4126-1)							
SET PRESSURE BAR	kg/min (Kdr=0.479)						
	DN15	DN20	DN25	DN32	DN40	DN50	DN65
1.0	75	134	209	343	536	837	1414
2.0	107	189	296	485	758	1183	2000
3.0	131	232	363	594	928	1449	2450
4.0	151	268	419	685	1072	1674	2829
6.0	185	328	513	840	1313	2050	3465
8.0	213	379	592	969	1516	2367	4001
10.0	239	423	662	1084	1695	2646	4473
12.5	267	473	740	1212	1895	2959	5001

To convert to galls/min multiply by 0.22.

In the above tables, discharge capacities have been calculated in accordance with BS EN 4126-1 & BS 6759,

using a derated coefficient of discharge (Kdr) 0.479, approved by AOTC.

For valves without diaphragm and completely leak proof (no vent hole), reduce flow capacity by 30% i.e. multiply stated capacities by 0.7.



Tel: +44 (0)1482 601030  
E-mail: [sales@nabicvalvesonline.co.uk](mailto:sales@nabicvalvesonline.co.uk)  
Web: [www.nabicvalvesonline.co.uk](http://www.nabicvalvesonline.co.uk)

Every effort has been made to ensure that the information contained in this publication is accurate at the time of publishing. NABIC Valves Online assumes no responsibility or liability for typographical errors or omissions or for any misinterpretation of the information within the publication and reserves the right to change without notice.

N\_Fig.500ST  
0116

## OUR GENIUS IS VALVES



call: +44 (0)1482 601030  
email: [sales@nabicvalvesonline.co.uk](mailto:sales@nabicvalvesonline.co.uk)  
web: [www.nabicvalvesonline.co.uk](http://www.nabicvalvesonline.co.uk)



View online, on mobile and on tablet  
[www.nabicvalvesonline.co.uk](http://www.nabicvalvesonline.co.uk)