

Replace STC

NOTE: AN AIR LEAK ON THE HIGH PRESSURE OIL PUMP SHAFT LIP SEAL IS NORMAL. THIS IS NOT AN INDICATION OF A HIGH PRESSURE OIL LEAK AND THE HIGH PRESSURE OIL PUMP SHOULD NOT BE REPLACED FOR THIS CONDITION.

Remove the high-pressure oil pump per WSM, Section 303-04C.

NOTE: DO NOT REMOVE THE BRANCH TUBE ASSEMBLY OR REAR COVER.

Mount the high pressure oil pump securely in a vise.

NOTE: IF THE HIGH-PRESSURE OIL PUMP AND BRANCH TUBE ADAPTER HAS AN ASSEMBLY SUPPORT BRACKET, REMOVE AND DISCARD THE ASSEMBLY SUPPORT, AND ALL ATTACHING HARDWARE. THIS WILL NOT BE REUSED.

Remove (unthread) the existing branch tube adapter and STC or jam nut fitting from the high-pressure oil pump. Discard either type of branch tube adapters.

Make sure to account for dowel (Figure 7)

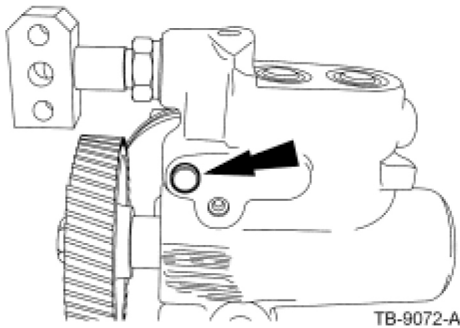

Figure 7 - Article 08-18-6

NOTE: IT IS NOT NECESSARY TO REPLACE THE HIGH PRESSURE PUMP WHEN REPLACING THE QUICK CONNECT FITTINGS.

CAUTION: TO PREVENT ENGINE DAMAGE, MATCH NEW O-RINGS WITH THE O-RINGS REMOVED. SEVERAL O-RINGS ARE SIMILAR IN SIZE, BUT WILL NOT SEAL IF USED IN THE WRONG LOCATION.

Prior to installing the new jam nut fitting, lubricate the entire jam nut fitting with clean engine oil, rotate the jam nut clockwise to the base of the branch tube adapter. The adapter is threaded to the jam nut. (Figure 8)

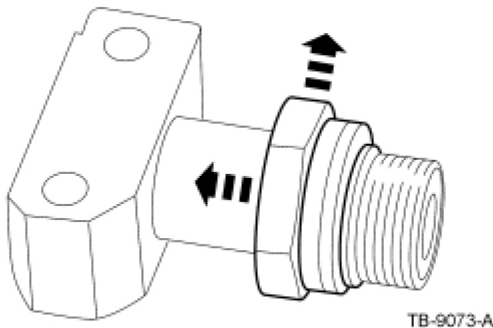

Figure 8 - Article 08-18-6

CAUTION: THE BRANCH TUBE ADAPTER MUST BE INSTALLED AT THE CORRECT DEPTH TO PREVENT HIGH PRESSURE OIL LEAKS.

Install the branch tube adapter into the high-pressure oil pump by threading it five (5) complete turns to set proper depth and set proper orientation. Tighten the jam nut to seat the O-ring at this time. (Figure 9)

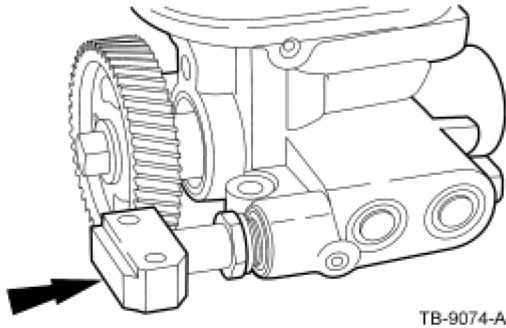

Figure 9 - Article 08-18-6

CAUTION: TO PREVENT ENGINE DAMAGE, BRANCH TUBE ADAPTER OIL OUTLET HOLE MUST FACE DOWN.

Loosen the jam nut 1/4 turn. Install holding tool using the supplied plastic bolts and wing nuts to align and position the jam nut fitting. (Figures 10 and 11)

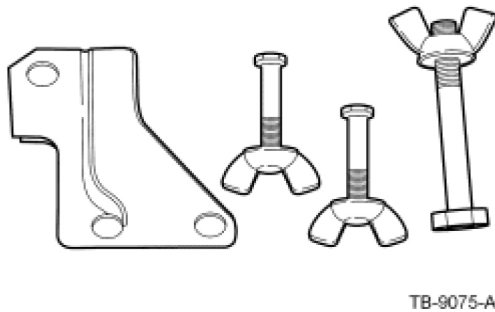

Figure 10 - Article 08-18-6

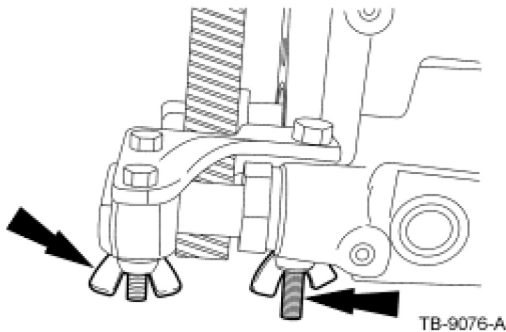

Figure 11 - Article 08-18-6

With plastic holding tool securely fastened, torque jam nut to 49 lb-ft (66 N-m) with a 15/16 crow foot open end wrench and torque wrench.

NOTE: TORQUE SPECIFICATION FOR STEP 8 IS CALCULATED FOR THE USE OF A CROW FOOT OPEN END WRENCH. Remove and discard holding tool, plastic bolts and wing nuts.

Lubricate and install a new O-ring in the branch tube inlet recess and in the high-pressure oil pump inlet recess.

CAUTION: TO PREVENT ENGINE DAMAGE THE OIL SUPPLY HOLE IN THE BRANCH TUBE ADAPTER MUST FACE THE BRANCH TUBE ASSEMBLY.

Install the high-pressure oil pump with branch tube adapter already installed. Use new bolts supplied in kit. Finger tighten the three (3) M 8x45 bolts securing the high-pressure oil pump to the crankcase and the two (2) M 6x30 bolts holding the branch tube adapter to the branch tube.

NOTE: NOTICE BRANCH TUBE ADAPTER TO BRANCH TUBE HOLE MISALIGNMENT IN MOST CASES THERE IS ENOUGH CLEARANCE IN THE BRANCH TUBE ASSEMBLY AND HIGH-PRESSURE OIL PUMP ASSEMBLY FOR PROPER HOLE ALIGNMENT. IF UNABLE, TO ALIGN HOLES THE BRANCH TUBE ASSEMBLY WILL HAVE TO BE REPLACED. (FIGURE 12)

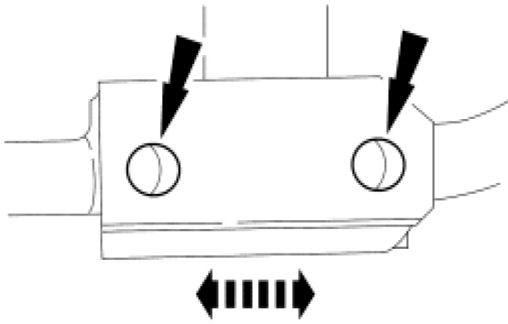

TB-9077-A

Figure 12 - Article 08-18-6