

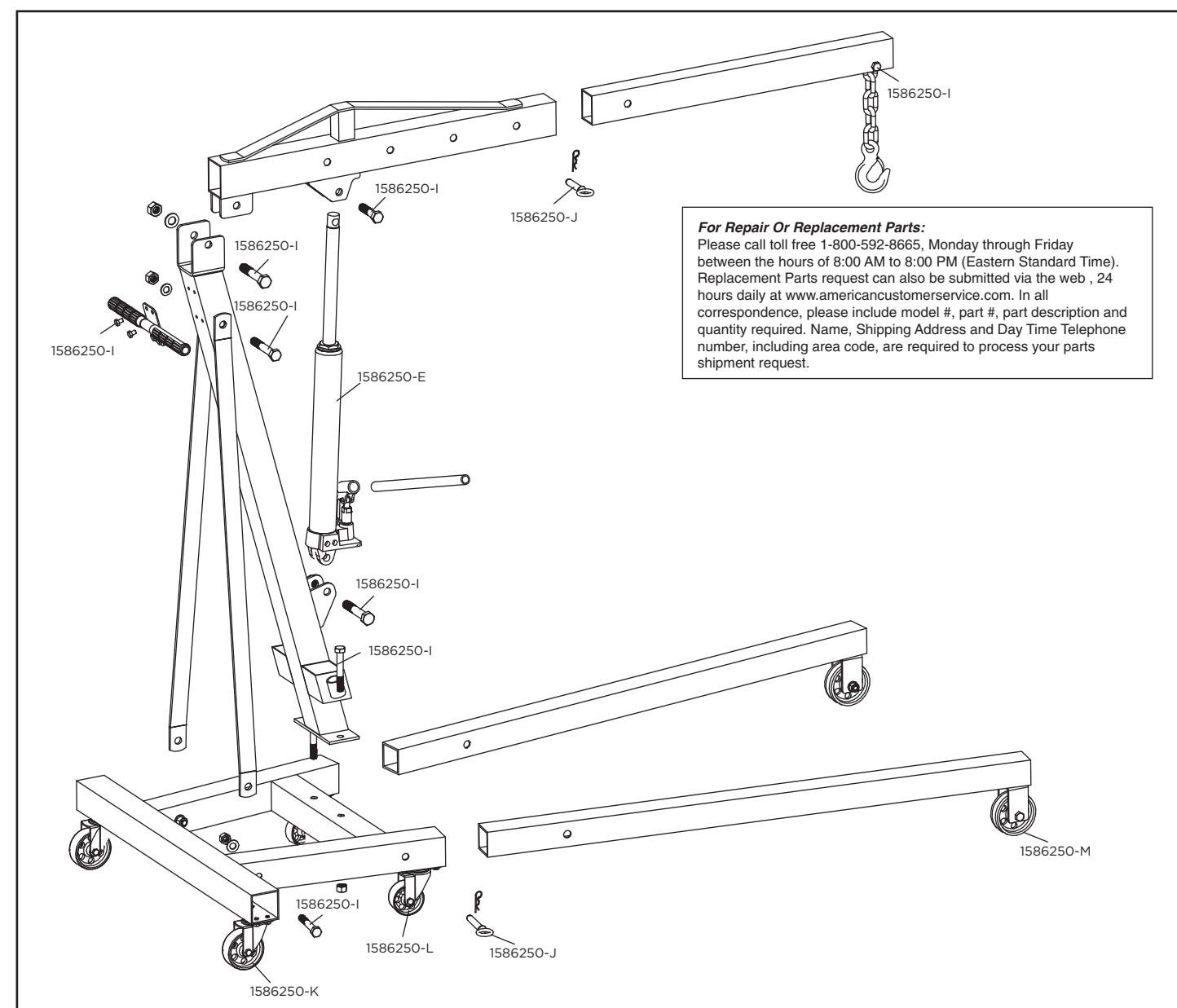

2 Ton (4,000 Lbs.) Mobile Engine Hoist Model 1586250 Replacing Parts List



For Repair Or Replacement Parts:
Please call toll free 1-800-592-8665, Monday through Friday between the hours of 8:00 AM to 8:00 PM (Eastern Standard Time). Replacement Parts request can also be submitted via the web, 24 hours daily at www.americancustomerservice.com. In all correspondence, please include model #, part #, part description and quantity required. Name, Shipping Address and Day Time Telephone number, including area code, are required to process your parts shipment request.

PARTS LIST

PART NO.	DESCRIPTION	Q'TY
1586250-E	Hydraulic Ram	1
1586250-I	Bolt M18 X 100	1
	Bolt M14 X 100	1
	Bolt M16 X 90	1
	Bolt M16 X 70	1
	Bolt M14 X 100	4
	Bolt M14 X 70	1
	Bolt M8 X 12	20

PART NO.	DESCRIPTION	Q'TY
1586250-J	Lock Pin	3
1586250-K	Caster 3-1/2"	2
1586250-L	Caster 3"	2
1586250-M	Wheel 3-1/2"	2



Malacate Movil Para Motores De 2 Toneladas (4,000 libras) Modelo 1586250 Lista de partes de reemplazo

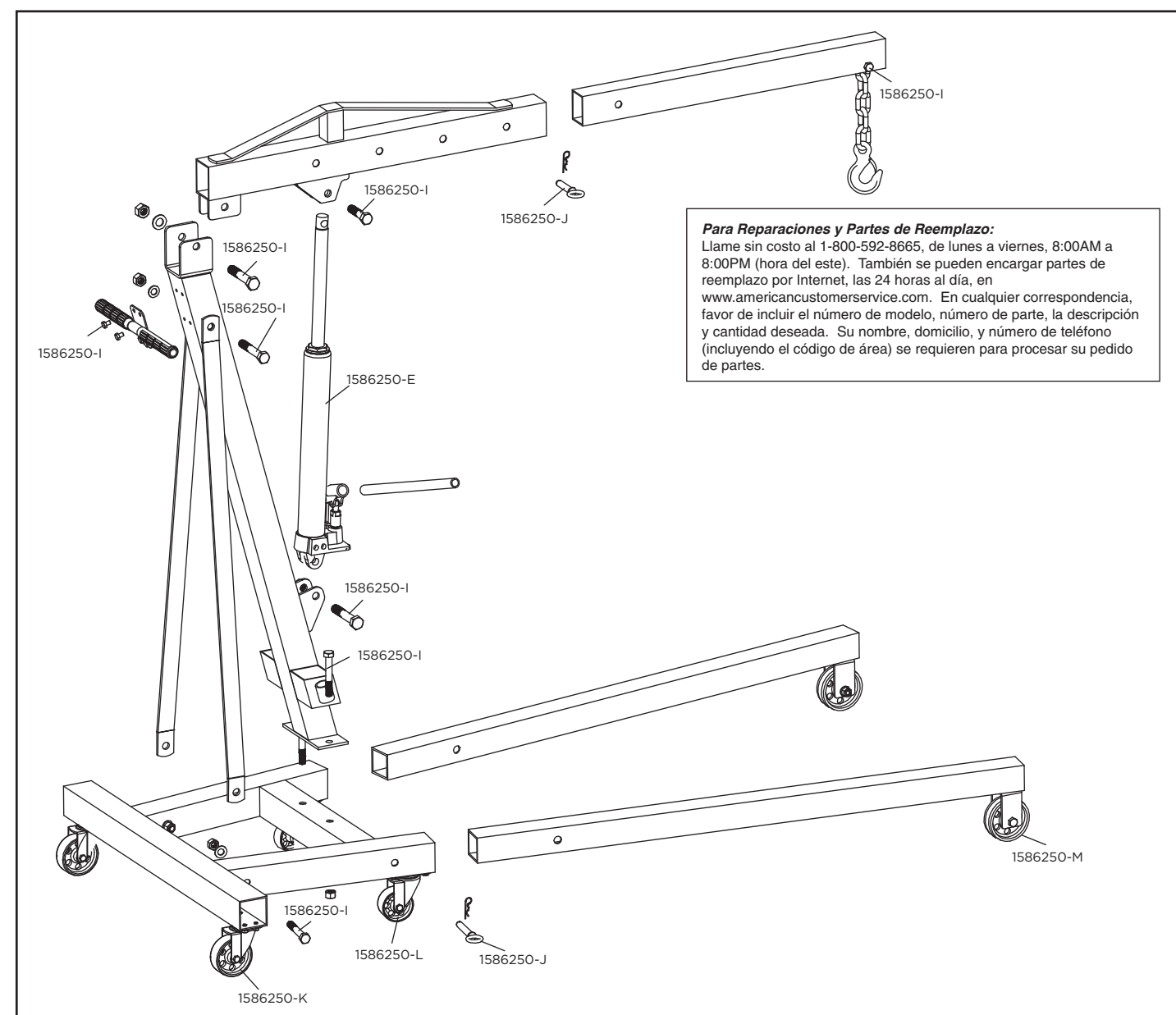

Para Reparaciones y Partes de Reemplazo:
Llame sin costo al 1-800-592-8665, de lunes a viernes, 8:00AM a 8:00PM (hora del este). También se pueden encargar partes de reemplazo por Internet, las 24 horas al día, en www.americancustomerservice.com. En cualquier correspondencia, favor de incluir el número de modelo, número de parte, la descripción y cantidad deseada. Su nombre, domicilio, y número de teléfono (incluyendo el código de área) se requieren para procesar su pedido de partes.

PARTS LIST

PZ. NO.	DESCRIPCIÓN	CANTIDAD
1586250-E	Pisón (Ariete) Hidráulico	1
1586250-I	Tornillo M18x100	1
	Tornillo M14x100	1
	Tornillo M16x90	1
	Tornillo M16x70	1
	Tornillo M14x100	4
	Tornillo M14x70	1
	Tornillo M8x12	20

PZ. NO.	DESCRIPCIÓN	CANTIDAD
1586250-J	Clavija De Traba	3
1586250-K	Rodaje 3-1/2"	2
1586250-L	Rodaje 3"	2
1586250-M	Ruedas 3-1/2"	2