



Sherwood™
Wood-Burning Fireplace



KINDRED
OUTDOORS + SURROUNDS



INTRODUCTION	3
SAFETY WARNINGS	4
GENERAL INFORMATION	5
PRODUCT USAGE	5
MODIFICATION OF FIREPLACE	5
MANTEL CLEARANCES	5
VENTILATION	5
COMBUSTIBLE CLEARANCES	5
DAMAGED PARTS	5
MAINTENANCE	5
DIMENSIONS	6
PARTS LIST	7
ISOKERN ASSEMBLY GUIDELINES	9
BROKEN COMPONENTS	9
LEVELING & ALIGNING COMPONENTS	9
NOTES	9
RECOMMENDED TOOLS	10
FIREPLACE INSTALLATION STEPS	10
FIREBRICK INSTALLATION	19
FINISHING FIREPLACE EXTERIOR	20
OPERATING INSTRUCTIONS	20
BUILDING A FIRE	20
DISPOSAL OF ASHES	20
3-YEAR LIMITED WARRANTY	21

Fireplace systems are designed for installation in accordance with the National Fire Protection Association Standard for Chimneys, Fireplaces, Vents and Solid Fuel-Burning Appliances (NFPA 211).



Since its discovery, fire has become much more than an essential element in our lives—it can set the mood in any environment. Now you can command the element of fire to enjoy its comfort and ambiance among family and friends. The Sherwood Fireplace from Kindred Outdoor creates a focal point in your open air conversation setting while providing the warmth and pleasant crackle of burning wood. A design statement, the Sherwood can be dressed with any stone and accessories to complement and enhance your outdoor living space. It's time to rediscover fire.

Image: **Sherwood** fireplace shown installed with a stacked stone.



SAFETY WARNINGS

WARNING

Before beginning installation of the Sherwood Fireplace, read these instructions carefully to be sure you understand them completely. Failure to follow them could cause fireplace malfunction resulting in serious injury or property damage.

Obtain necessary permits from authorities in your local jurisdiction and comply with all local building codes.

To avoid the risk of damaging fireplace materials and increasing risk of spreading fire, do not use the fireplace to cook or warm foods.

This unit has not been tested for use with doors. To reduce the risk of injury, do not install doors.

Do not over burn.

This product has not been tested for use with a chase. To reduce the risk of fire, do not install a chase.

Do not pack air spaces with insulation or other materials.

Creosote and soot formation and the need for its removal: When wood is burned slowly, it produces tar and other organic vapors which combine with expelled moisture to form creosote. The creosote vapors condense in the relatively cool chimney flue of a slow burning fire. As a result, creosote residue accumulates on the flue lining. When ignited this creosote makes an extremely hot fire. Because of creosote and soot buildup, it is necessary to inspect and clean the fireplace and chimney prior to use and periodically during the heating season. Cleaning of the fireplace and the chimney system should be done annually at a minimum. In colder climates, chimney cleaning may need to be done more often, periodically throughout the heating season.

Before servicing, allow the fireplace to cool. Always shut off any electricity or gas to the fireplace while working on it.

Never use gasoline, kerosene, gasoline-type lantern fuel, charcoal lighter fluid, or similar liquids to start or “freshen up” a fire in this fireplace. Keep all flammable liquids at a safe distance from the fireplace.

Burning some fuels (such as charcoal) can be hazardous due to the possibility of producing carbon monoxide, a colorless, odorless gas. Early signs of carbon monoxide poisoning resemble flu symptoms including headaches, dizziness or nausea. Overexposure to carbon monoxide can lead to illness and death.

CAUTION

Do not burn large amounts of paper, cardboard, tree branches or building construction materials. The intense fires these products create may overheat the fireplace thus causing damage to the unit or a potential fire outside the firebox.



GENERAL INFORMATION

PRODUCT USAGE

The Sherwood Fireplace is designed to burn solid woods or gas outdoors. This unit is not designed to sit directly against combustible materials. This unit is not designed to be built into a wood structure. The Sherwood Fireplace is designed as an outdoor unit only. As required due to heat and weight, this unit must be built on a non-combustible concrete slab (code-compliant frost-free footer) designed to carry the total weight of the entire fireplace and chimney structure along with finished veneer. Approximate weight of installed unit is 4175 lbs. (excluding stone veneer finish).

Use solid wood, plumbed propane or natural gas fuel only.

BTU gas set used with this product must be approved for outdoor use.

MODIFICATION OF FIREPLACE

Modifications to the Sherwood Fireplace are prohibited. Any modifications may void claims, listings and approvals and could result in an unsafe and potentially dangerous installation.

The installer indemnifies the manufacturer of all claims and under no circumstances will manufacturer be liable for consequential, incidental, indirect, punitive or other damages of any kind or nature, whether foreseeable or not, based on any claim by any party as to the modifications of the fireplaces.

MANTEL CLEARANCES

A decorative mantel may be installed above the firebox opening of the Sherwood Fireplace provided the front edge of the mantle extends no more than 10" from the face of the fireplace and is a minimum of 12" above the opening (**Figure A**).

VENTILATION

The Sherwood Fireplace is designed as an outdoor unit only. No additional ventilation or circulation is required.

COMBUSTIBLE CLEARANCES

The distances to combustibles while burning solid wood shall be no less than 60" from the front of firebox, 12" from the side walls and 4" from the back wall. When a vented or ventless gas log set is used and the top of the chimney capped, the clearances shall be no less than 16" from the front, 4" from the back and 1" from the top of the chimney.

DAMAGED PARTS

If unit is delivered with obvious damage due to freight, please notify driver or refuse delivery. If product is damaged on job site, you may be able to repair unit using adhesive and/or mortar. If damage is severe, contact your dealer to arrange shipment of replacement parts.

MAINTENANCE

Please contact a professional chimney sweep at least once each year to inspect and make recommendations regarding the maintenance of your outdoor fireplace. In the event you have added a decorative chimney termination or rain cap to your fireplace, please be prepared to inform the chimney sweep as to the best method to perform proper inspection/maintenance.

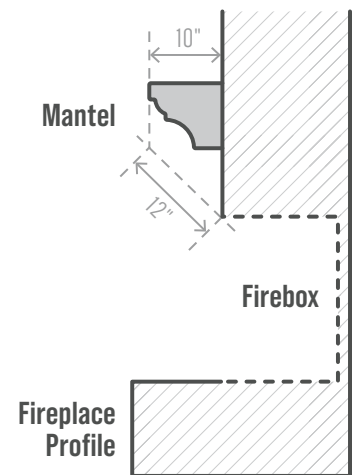
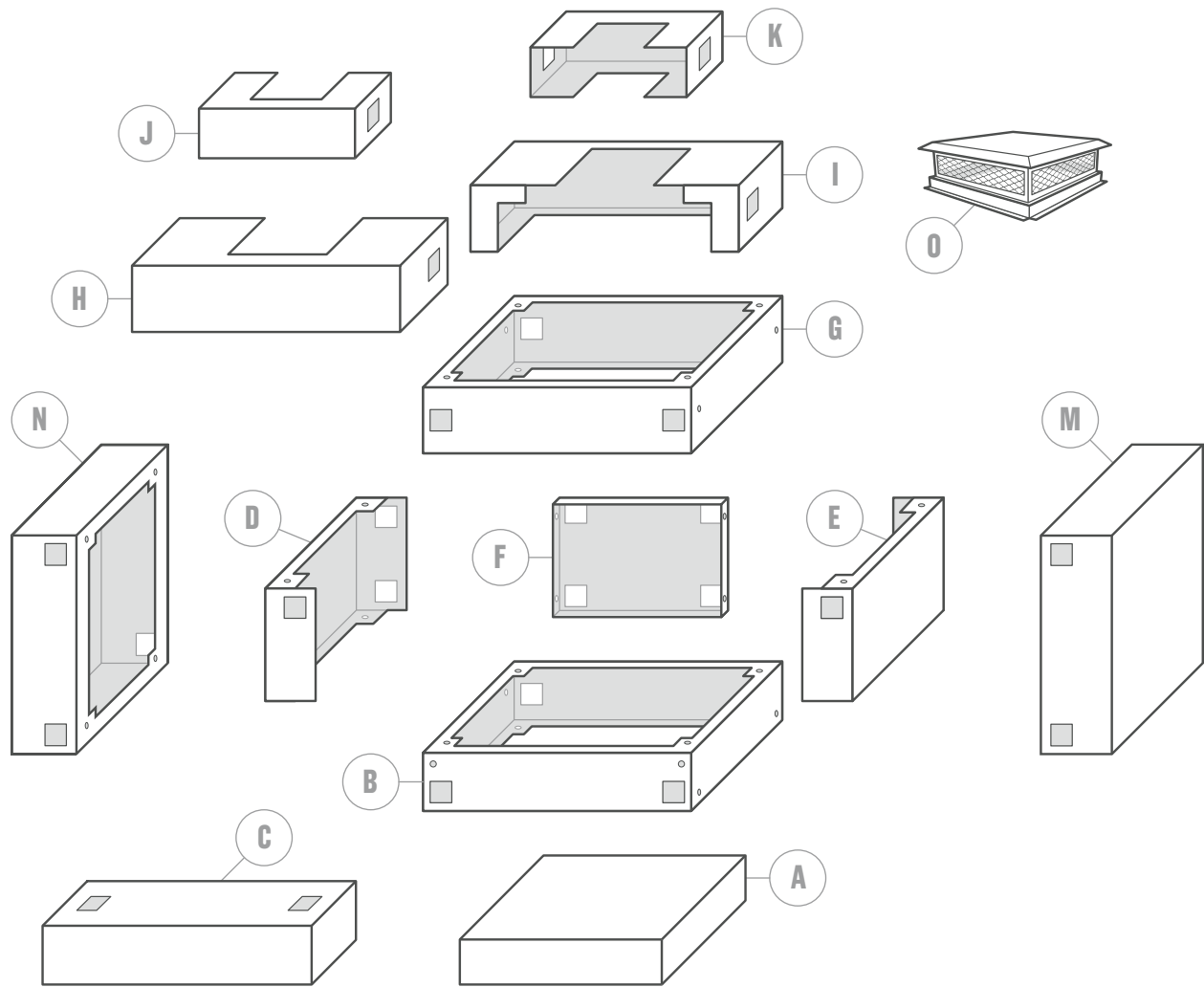

Figure A



PARTS LIST

EXTERNAL COMPONENTS-SHELL, BASE & CHIMNEY CAP



ITEM	PART	QTY.
A	Base Support	1
B	Base Sleeve	1
C	Hearth	1
D	Left Side Unit	1
E	Right Side Unit	1
F	Back Panel	1
G	Cross-Section Sleeve	1
H	Smoke Dome Sleeve-Front	1
I	Smoke Dome Sleeve-Back	1

ITEM	PART	QTY.
J	Chimney Sleeve-Front	1
K	Chimney Sleeve-Back	1
M	Fireplace Side Extension-Right	1
N	Fireplace Side Extension-Left	1
O	Chimney Cap	1
—	Bolts (.75" × 3.5")	36
—	Washers	76
—	Nuts	36
—	Cavity Plugs	36



PARTS LIST Continued

INTERNAL COMPONENTS BY ISOKERN

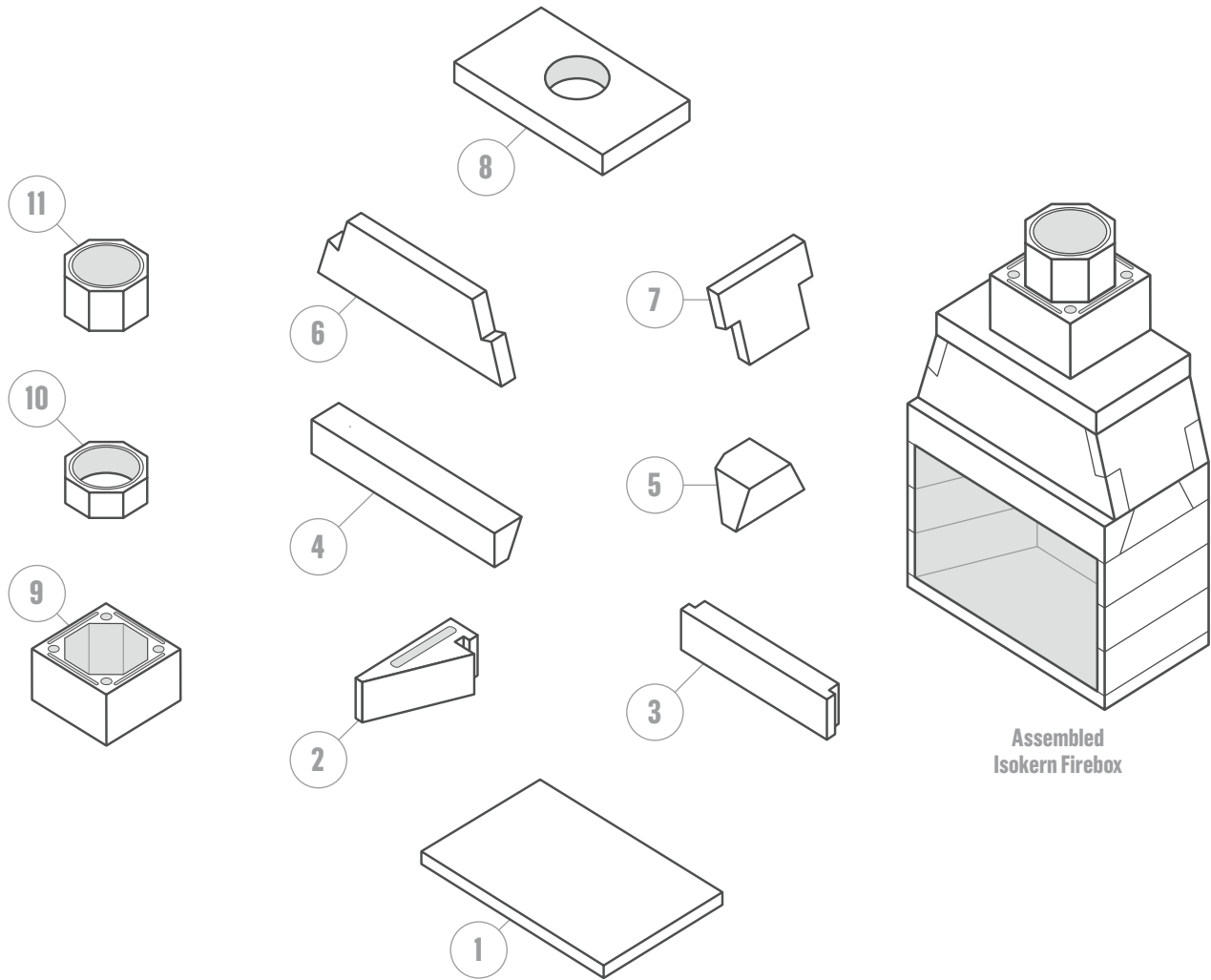

**Assembled
Isokern Firebox**

ITEM	PART	QTY.
1	Firebox Base Plate	1
2	Firebox Side Wall	6
3	Firebox Back Wall	3
4	Damper Beam	2
5	Damper Support	2
6	Smoke Dome	2
7	Smoke Dome Sloping Sides	2

ITEM	PART	QTY.
8	Smoke Dome Top Plate	1
9	Chimney Casing Block	1
10	6" Interior Chimney Liner	1
11	12" Interior Chimney Liner	1
—	Isokern Mortar	5 Gallons
—	Alsey Firebrick & Flue-Set Refractory Mortar	38 Sq. Ft.
—	PL Adhesive	2



ISOKERN ASSEMBLY GUIDELINES

Isokern Mortar (a thin-set type masonry adhesive) is used to glue all Isokern components together during field assembly of the unit. Five gallons of the mortar is supplied dry. No other mortar is approved for use when assembling Isokern parts. Use of a mortar other than Isokern MP50 (included) will void the warranty.

Isokern Mortar is mixed with clean water to a smooth, workable texture (without lumps or dry pockets) of a “toothpaste” consistency. This mixture is suitable for application onto Isokern components by using a masonry grout bag supplied with the unit.

Attention should be paid that the mortar mixture is not too thin or runny, as this will not allow the mortar to reach its maximum bonding strength.

Isokern Mortar is squeezed from a grout bag onto the contact surfaces of the Isokern components as they are fitted together.

It is important that a ½" bead of mortar on all the components' contact surfaces is applied at about ½" in from all edges of the contact surface of the component (**Figure B**).

When setting the next component onto the mortared contact surface of the first component, some mortar should squeeze out along the face of the entire joint as a sign of complete and proper sealing of the joint. On broader contact surfaces it is advisable to apply several additional ½" beads of the Isokern Mortar to the area to assure proper sealing of the joint.

Properly mortared firebox and smoke dome assembly requires approximately 30 lbs. (dry measure) of Isokern Mortar.

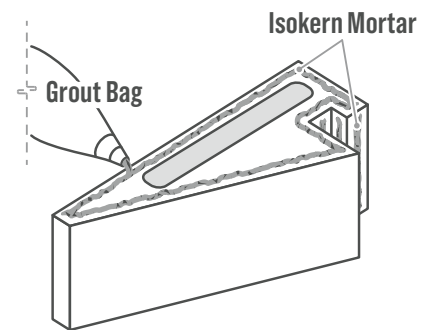

Firebox Side Wall

Figure B

BROKEN COMPONENTS

Components broken into 2 or 3 pieces can be repaired by using Isokern Mortar along the break line as the component is set into place. Components broken into multiple small pieces should be discarded and replaced.

LEVELING & ALIGNING COMPONENTS

Be sure to assemble all Isokern components level and flush with adjoining components.

Isokern Mortar is not intended to create a mortar joint of any thickness for leveling purposes. Therefore, leveling and alignment adjustments are made by the use of small plastic shims supplied with the unit (**Figure C**).

The shims can be inserted under a component to level and align it with adjacent Isokern components. Be sure to re-grout any and all gaps resulting from shim insertion to maintain components to full bearing.

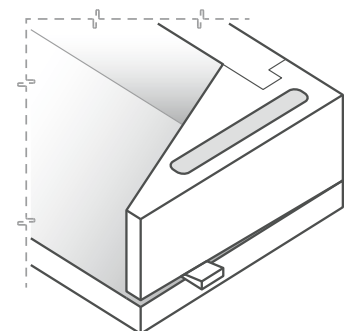

Shim If Required to Achieve Correct Height

Figure C

NOTES

1. Do not mix Isokern Mortar with spirits or anti-freeze agents.
2. The maximum recommended mortar joint thickness at Isokern components is ¼".



RECOMMENDED TOOLS

The following list of tools will make your installation a smooth process and give the best results:

- | | | | |
|-------------------------|-------------------|------------------|--|
| 1. Flathead Screwdriver | 4. Pencil | 7. Tape Measure | 10. Gloves (recommended for handling GFRC) |
| 2. 3/4" Wrench | 5. Level | 8. Caulking Gun | 11. Power Mixer (optional) |
| 3. 3/16" Drill Bit | 6. Framing Square | 9. 2 Step Stools | |

FIREPLACE INSTALLATION STEPS

The following steps combine the Sherwood components with the Isokern components to create a durable, time-tested masonry outdoor fireplace. Sherwood components are identified with letters, and Isokern components are identified with numbers.

1 BEGIN BASE ASSEMBLY

Parts: Base Support (Part A)

Mortar Type: N/A

- Place the Base Support in its final installation location. The firebox will be centered on this unit.
- Use shims to level the Base Support, if necessary.



2 PLACE ISOKERN FIREBOX BASE

Parts: Isokern Firebox Base Plate (Part 1)

Mortar Type: Isokern Mortar

- Set the Isokern Firebox Base Plate in a full bed of Isokern Mortar flat on the Base Support.
- Level the Base Plate by floating it in a bed of Isokern Mortar to full bearing against the underlying Base Support surface.



3 COMPLETE BASE ASSEMBLY

Parts: Base Sleeve (Part B)

Mortar Type: N/A

- Place the Base Sleeve over the Base Support and Plate assembly with access openings facing front of Fireplace. The Base Sleeve should fit snug and level around both the Base Support and Plate pieces.





4

ADD HEARTH

Parts: *Hearth (Part C) +*

2 qty. Bolts, 4 qty. Washers & 2 qty. Nuts

Mortar Type: *Construction Adhesive*

- Place the Hearth in front of the newly created base assembly. The access openings should face and align to the access openings on the front of the Base Sleeve.
- Test bolts through bolt holes to ensure pass-through.
- Apply construction adhesive to the backside of the Hearth and slide into position making sure to line-up the bolt holes of both units.
- Using the access openings, connect the Hearth to the Base Sleeve with 2 Bolts, using 2 Washers and a Nut for each bolt. Tighten with a $\frac{1}{4}$ turn past snug.

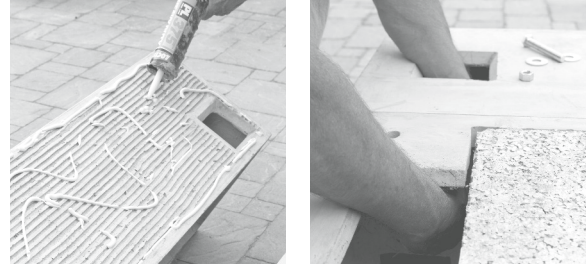

5

PLACE FIREPLACE LEFT SIDE

Parts: *Left Side Unit (Part D) +*

2 qty. Bolts, 4 qty. Washers & 2 qty. Nuts

Mortar Type: *Construction Adhesive*

- Place Left Side Unit on base assembly.
- Apply construction adhesive to the bottom of the Left Side Unit and slide into position along the left edge of Base Sleeve, making sure to line-up the bolt holes of both units.
- Using the access openings, connect the Left Side Unit to the Base Sleeve with 2 Bolts, using 2 Washers and a Nut for each bolt. Do not tighten bolts all the way until step 7 is complete.



6

PLACE FIREPLACE RIGHT SIDE

Parts: *Right Side Unit (Part E) +*

2 qty. Bolts, 4 qty. Washers & 2 qty. Nuts

Mortar Type: *Construction Adhesive*

- Place Right Side Unit on base assembly.
- Apply construction adhesive to the bottom of the Right Side Unit and slide into position along right edge of Base Sleeve, making sure to line-up the bolt holes of both units.
- Using the access openings, connect the Right Side Unit to the Base Sleeve with 2 Bolts, using 2 Washers and a Nut for each bolt. Do not tighten bolts all the way until step 7 is complete.

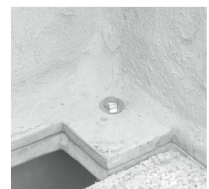



FIREPLACE INSTALLATION STEPS Continued

7 PLACE FIREPLACE BACK PANEL

Parts: Back Panel (Part F) +
4 qty. Bolts, 8 qty. Washers & 4 qty. Nuts

Mortar Type: Construction Adhesive

- Place Back Panel between the Left and Right Side Units.
- Apply construction adhesive to the bottom and exterior sides of the Back Panel. Slide the Back Panel into position flush along the rear edge of the Base Sleeve, making sure to line-up all appropriate bolt holes.
- Using the access openings, connect the Back Panel to the Left and Right Side Units with the 4 Bolts, using 2 Washers and a Nut for each bolt. Tighten all 4 bolts for the Fireplace Back Panel and then continue to tighten all bolts for the Right and Left Side Units. Tighten bolts a $\frac{1}{4}$ turn past snug.

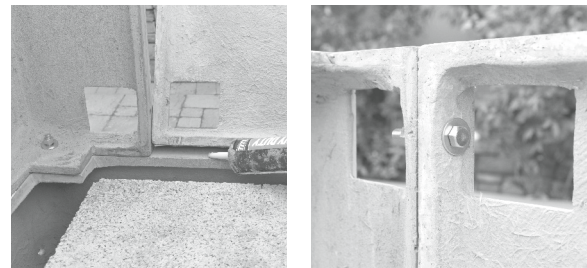

8 BEGIN ISOKERN FIREBOX ASSEMBLY

Parts: 2 qty. Isokern Firebox Side Walls (Part 2) +
1 qty. Isokern Firebox Back Wall (Part 3)

Mortar Type: Isokern Mortar

- Dry-set the first level of Firebox Side & Back Walls on top of the Base Plate of the base assembly. Set the outside edges flush with the Isokern base plate.
- Trace the position of all 3 pieces in place on the Base Plate with a pencil.
- Remove the Firebox Side and Back Walls and apply a $\frac{1}{2}$ " layer of Isokern Mortar to the traced outline on the Base Plate.
- Set each piece back in place on the Base Plate, applying Isokern Mortar to all contact surfaces (see Figure A) of vertical joints where the Firebox Side Walls and Back Wall components connect. Start by positioning the left piece first, then place the right and connect the two with the back piece.
- If necessary, adjust the top surface of the firebox assembly for level by inserting a shim between the lowest wall component and the top surface of the base plate.
- Any gap created under the firebox wall components during the shim-leveling process must be filled with Isokern Mortar to full bearing against the Base Plate.

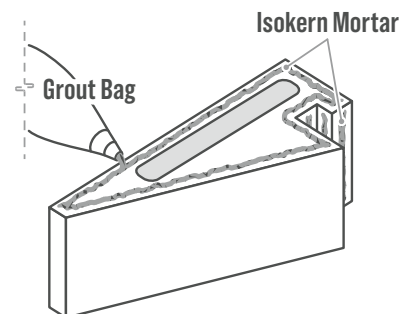

Firebox Side Wall

Figure A



9 COMPLETE ISOKERN FIREBOX ASSEMBLY

Parts: 4 qty. Isokern Firebox Side Walls (Part 2) +
2 qty. Isokern Firebox Back Walls (Part 3)

Mortar Type: Isokern Mortar

- Continue assembly of two additional levels using the Firebox Side and Back Walls. Apply Isokern Mortar to the top of each level's components, then set the next level above into place. Be sure to mortar all vertical joints of the Firebox Side Walls to Back Wall connections when setting each component in place.
- When all of the Firebox Side and Back Wall components are set, check the top surface of the firebox for level.
- If necessary, adjust the top surface of the firebox assembly for level by inserting a shim between the lowest wall component and the top surface of the base plate.
- Any gap created under the firebox wall components during the shim-leveling process must be filled with Isokern Mortar to full bearing against the Base Plate.



10 INSPECT ISOKERN FIREBOX

Parts: N/A

Mortar Type: Isokern Mortar

- Make sure that the firebox wall assembly has been set level and square.
- Adjust as required while the mortar is still wet.
- Make a final inspection of all contact joints in the firebox wall assembly to be sure they are properly sealed.
- Use a trowel and Isokern Mortar to fill in all gaps and smooth over all seams between Isokern parts.





FIREPLACE INSTALLATION STEPS Continued

11 BEGIN ISOKERN DAMPER ASSEMBLY

Parts: 1 qty. Isokern Damper Beam (Part 4) +
2 qty. Isokern Damper Supports (Part 5)

Mortar Type: Isokern Mortar

- Dry-set a Damper Support in position on top of both the right and left walls of the firebox wall assembly. Rest a Damper Beam across the rear of the firebox wall assembly. All exterior edges of the damper components must be flush to the exterior edges of the firebox wall assembly.
- Once all pieces are in position, remove the Damper Support on the left and apply Isokern Mortar to the bottom and vertical contact surfaces; set back into position. Repeat this process for the Damper Support on the right and the rear Damper Beam.

NOTE: Leave the front Damper Beam off until after Step 12 has been completed.



12 PLACE CROSS-SECTION SLEEVE

Parts: Cross-Section Sleeve (Part G) +
4 qty. Bolts, 8 qty. Washers & 4 qty. Nuts

Mortar Type: Construction Adhesive

- Lift the Cross-Section Sleeve up and over damper assembly and set in place on top of the Fireplace Left (Part D) and Right (Part E) Side Units. The Cross-Section Sleeve should sit flush with both Left and Right Side Units and Back Panel.
- Apply construction adhesive to the bottom of the Cross-Section Sleeve and set in place making sure to line-up all appropriate bolt holes.
- Using access openings, connect the Cross-Section Sleeve to the Left and Right Side Units with 4 bolts, using 2 washers and a nut for each bolt. Tighten with a ¼ turn past snug.

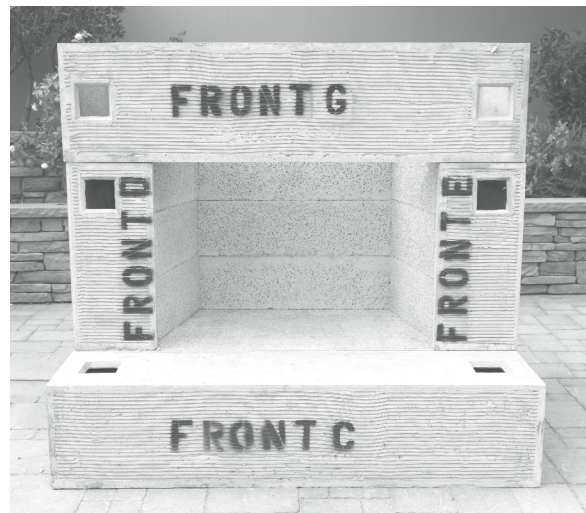

13 COMPLETE ISOKERN DAMPER ASSEMBLY

Parts: 1 qty. Isokern Damper Beam (Part 4)

Mortar Type: Isokern Mortar

- Once the Cross-Section Sleeve is bolted in place, use Isokern Mortar on the last remaining Damper Beam and set it in the front position of the damper assembly.





14 BEGIN ISOKERN SMOKE DOME ASSEMBLY

Parts: 2 qty. Isokern Smoke Domes (Part 6) +
2 qty. Isokern Smoke Dome Sloping Sides (Part 7)

Mortar Type: Isokern Mortar

- Dry set the Smoke Dome and Sloping Side pieces into position before adhering with mortar. When applying mortar, be sure to cover all contact surfaces thoroughly.
- Set one Smoke Dome component across the rear Damper Beam in a bed of mortar, flush with the rear edge of the damper assembly.
- Set the other Smoke Dome component in mortar across the front Damper Beam, 2¼" back from the edge of the front lintel. This placement should create a space of 17" between the front and rear Smoke Dome components.
- Position the Smoke Dome Sloping Sides at each end of the Smoke Dome components. The Sloping Sides have a beveled bottom to fit flat on the top of the damper assembly.

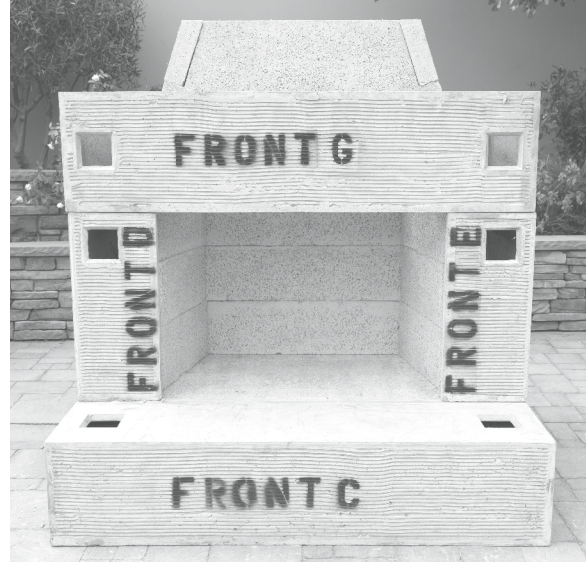

15 COMPLETE ISOKERN SMOKE DOME ASSEMBLY

Parts: Isokern Smoke Dome Top Plate (Part 8)

Mortar Type: Isokern Mortar

- Place the Smoke Dome Top Plate on top of the smoke dome walls. The side of the Top Plate showing a thickened center is the bottom. The flue hole is centered from side to side but is offset from front to back; the center of the flue hole should rest 10¾" from the back of the firebox. Position the top plate so that the flue hole sits closer to the backside of the unit.
- Set the Smoke Dome Top Plate with Isokern Mortar; be sure to mortar all contact surfaces thoroughly.
- Use a trowel and Isokern Mortar to fill in all gaps and smooth over all seams between Isokern parts.



FIREPLACE INSTALLATION STEPS Continued**16** BUILD SMOKE DOME SLEEVE

Parts: Smoke Dome Sleeve–Front (Part H) +
Smoke Dome Sleeve–Back (Part I) +
4 qty. Bolts, 8 qty. Washers & 4 qty. Nuts

Mortar Type: Construction Adhesive

- First, position the Smoke Dome Sleeve–Back (Part I) piece over smoke dome assembly on top of the Cross-Section Sleeve. Set the piece by applying construction adhesive to the interior connecting walls and bottom surfaces and push in place. Tighten bottom bolts only.
- Position the Smoke Dome Sleeve–Front (Part H) piece over smoke dome assembly on top of the Cross-Section Sleeve. Set the piece by applying construction adhesive to the interior connecting walls and bottom surfaces and push in place.
- Using the access openings, bolt the Smoke Dome Sleeve–Front and Back together and to the Cross-Section Sleeve underneath using 4 bolts, using 2 washers and a nut for each bolt. Tighten with a $\frac{1}{4}$ turn past snug.

**17** BUILD ISOKERN CHIMNEY ASSEMBLY

Parts: Isokern Chimney Casing Block (Part 9) +
Isokern 6" Interior Chimney Liner (Part 10) +
Isokern 12" Interior Chimney Liner (Part 11)

Mortar Type: Isokern Mortar

- Set the Chimney Casing Block in a bed of Isokern Mortar on top of the Smoke Dome Top Plate centered from side to side and flush with the back of the smoke dome assembly. Make sure that the interior of the Chimney Casing Block aligns with the flue hole in the Smoke Dome Top Plate. The recessed grooves in the Chimney Casing Block should face downwards with the raised grooves facing upwards.
- Next, set the 6" Interior Chimney Liner inside the outer casing block. The 6" Interior Chimney Liner has a female and a flat end; set with the flat end down into Isokern Mortar so that it is fully sealed to the smoke dome assembly.
- Apply Isokern Mortar to the top of the 6" Interior Chimney Liner and set the 12" Interior Chimney Liner on it. The top of this liner will sit 6" above the top of the Chimney Casing Block that was previously set.





18

BUILD CHIMNEY SLEEVE

Parts: Chimney Sleeve–Front (Part J) +
Chimney Sleeve–Back (Part K) +
4 qty. Bolts, 8 qty. Washers & 4 qty. Nuts

Mortar Type: Construction Adhesive

- Position the Chimney Sleeve–Front and Back pieces around the firebox chimney assembly. The Chimney Sleeve–Back (Part K) should sit flush with Smoke Dome Sleeve–Back (Part I). Set the two halves by applying construction adhesive to the interior connecting walls and bottom surfaces and push in place.
- Using the access openings, bolt the Chimney Sleeve–Front and Back together and to the Smoke Dome Sleeve underneath using 4 bolts, using 2 washers and a nut for each bolt. Tighten with a $\frac{1}{4}$ turn past snug.

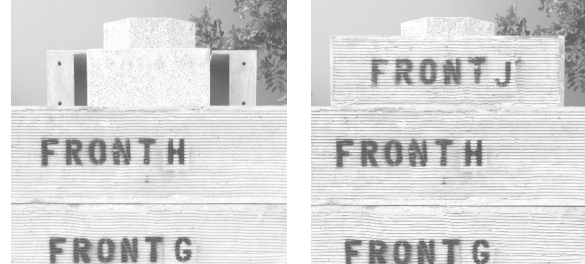

19

ADD FIREPLACE SIDE EXTENSIONS

Parts: Side Extension–Right (Part M) +
Side Extension–Left (Part N) +
4 qty. Bolts, 8 qty. Washers & 4 qty. Nuts

Mortar Type: Construction Adhesive

- Set a Fireplace Side Extension to both sides of the main fireplace assembly. Level and shim if necessary. Apply construction adhesive to the interior facing side walls and push in place.
- Using the access openings, bolt each Side Extension to the connecting Fireplace Right or Left Side Unit with 4 bolts for each extension, using 2 washers and a nut for each bolt. Tighten with a $\frac{1}{4}$ turn past snug.

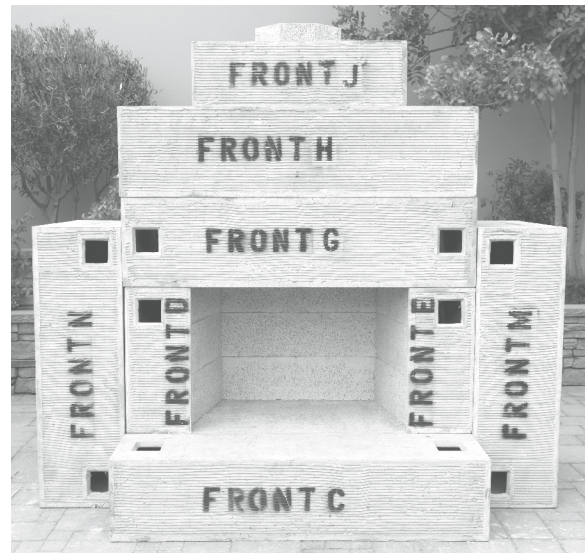



FIREPLACE INSTALLATION STEPS Continued

20 ADD CAVITY PLUGS

Parts: 36 qty. Cavity Plugs

Mortar Type: Construction Adhesive

- a) Upon completion of the fireplace assembly, use the beveled Cavity Plugs to cover all access hole openings. Apply construction adhesive to the beveled edges of each cap before pushing in place.



21 ADD CHIMNEY CAP

Parts: Chimney Cap

Mortar Type: N/A

- a) Set the stainless steel Chimney Cap on top of Chimney Sleeve and position over the center of the Isokern Chimney Liner.
- b) Once the Chimney Cap is in position, use a $\frac{3}{16}$ " drill bit to create pilot holes for the Chimney Cap.
- c) Use the screws provided to anchor the Chimney Cap onto the Chimney Sleeve.
- d) Wall cap accessories may be installed over top of the horizontal Chimney Cap flange and grouted in place.

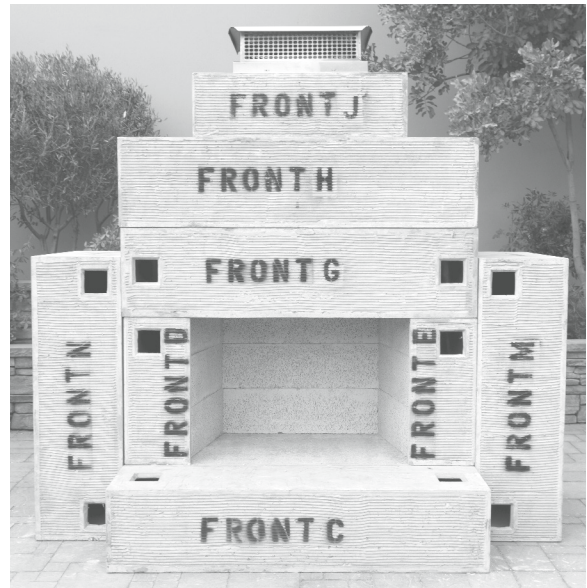



FIREBRICK INSTALLATION

The manufacturer requires that the firebox be lined with a minimum 1-1/4" thick firebrick (included). Thicker firebrick may be used as an option. The pattern for the firebrick lining is also an owner option.

Use the supplied Flue-Set Refractory Mortar to adhere the firebrick to the inside of the firebox and create the finished face joints of the brickwork. Mixing instructions may vary because of different climates and conditions. The use of good masonry practices for your area should also be considered. All required through-wall accesses (gas & electrical line feeds and combustion air supply access holes) should be drilled BEFORE the required firebrick lining is installed.

Mix 50lb bag with 3.75 quarts of clean water or .75 quarts per 10 lbs. of dry product until completely blended. Only mix what can be utilized within 15 minutes; do not retemper (the addition of water after the chemical reaction has begun). The use of warm water will accelerate setup.

Complete set time is between 48 and 72 hours. For best results, please allow 7 days before heat is applied.

CAUTION: Do not add additives such as fireclay, sand, cement, or other accelerators.

APPLYING FIREBRICK

1. Wet mop the inside of the firebox with a damp sponge to remove dust and loose particles from the interior before installing firebrick.
2. Determine your pattern and face joint dimensions. Face joint dimensions of 1/8" to 1/4" in the brickwork is recommended and has the best appearance. Other face joint dimensions are acceptable however smaller joints may not leave room for heat expansion of firebrick.

HINT: Dip each firebrick into water before applying.

3. Start the firebrick at the front edge of the floor of the Isokern firebox, proceeding inward toward the back. Give the floor brick a gap of approximately 1/2" from the back and side walls (**Figure A**). This air space allows heat expansion of the fire brick and is to be left empty of mortar.
4. Next, adhere firebrick to the back wall of the unit. The firebrick on the back wall will cover up the 1/2" expansion gap left on the brick floor along the back wall of the firebox. Give the firebrick on the back wall a gap of approximately 1/2" from the side walls (**Figure B**).
5. Set the side walls firebrick by starting at the front edge and work towards the back. The side wall firebrick, when completed, covers up the 1/2" expansion gaps on both the floor and back side walls where the firebrick was held off (**Figure C**).

NOTE: It is typical for heat stress cracks to appear in the firebrick in fireplaces.

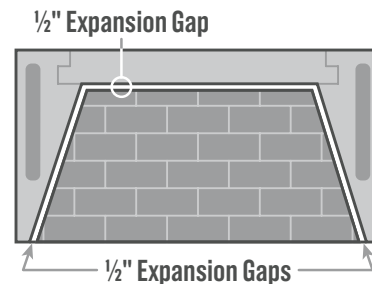

Figure A (Overhead View):
Set Firebrick on Floor FIRST

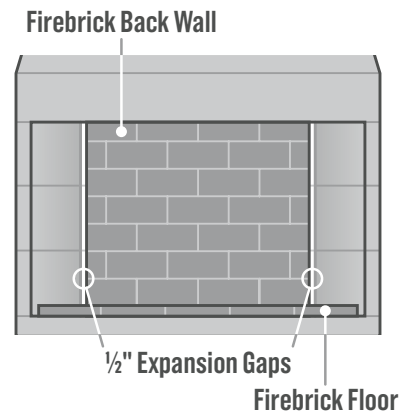

Figure B (Front View):
Set Firebrick on Back Wall SECOND

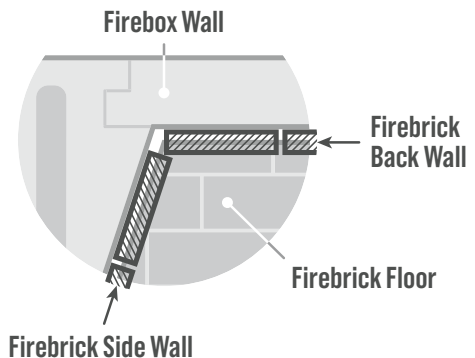

Figure C (Overhead View-Left Corner):
Set Firebrick on Side Walls LAST



FINISHING FIREPLACE EXTERIOR

Customize your Wood-Burning Fireplace by dressing it with an application of stone, brick, natural veneer or stucco.

Enhance the aesthetic and tactile appeal of your next project with the natural textures and authentic color palettes of high-performance architectural stone veneer.

OPERATING INSTRUCTIONS

This part of the manual covers methods to maximize the performance of your fireplace. If you are having trouble with your Sherwood fireplace, please contact your installer or call 1-800-925-1491 for assistance.

Use a log grate to place under the fuel when using solid wood fuels. We recommend using hardwood dried 6 to 12 months for best results. The ideal moisture content for wood burning is 15-19%. This allows for the best heat output and cleanest burn. Moisture meters are available at many hardware stores. Place wood in firebox with ample air space between logs.

BUILDING A FIRE

Start by placing some kindling in the center of your fireplace grate [see callout (A) in illustration below]. Then lay one split section of log across each side of the kindling (B), placing the pieces of wood so that the ends nearer to the back of the fireplace (C) are closer together than the ends at the front. The wood should not extend more than an inch beyond the front of the grate or it may cause smoke to move out the front of the unit. Now lay an additional one or two pieces of wood across the two side logs (D). Push these top logs all the way to the back (E) so the rear log lies against the back wall of the fireplace.

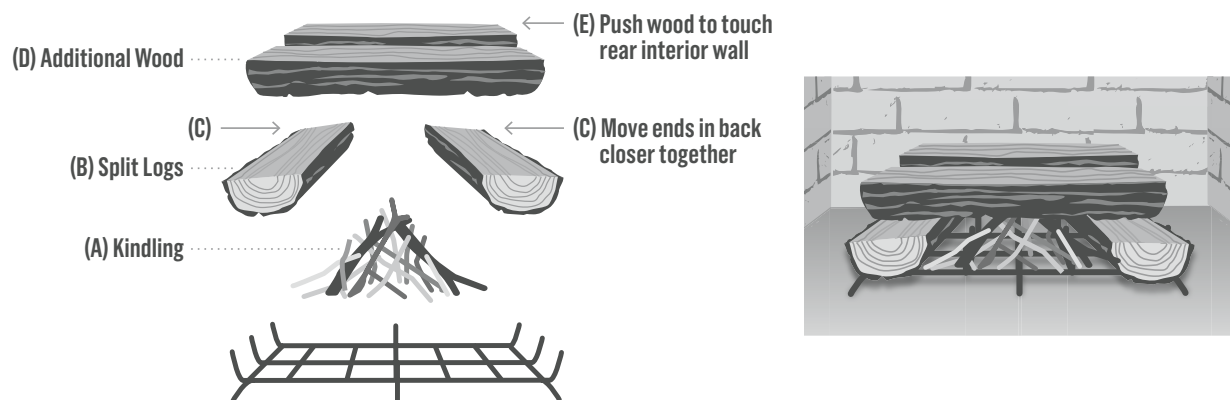

DISPOSAL OF ASHES

- Keep the base of the fireplace clean of excess ash accumulation. This will prevent grate “burn-out.”
- Keep the area directly underneath the burning logs free of ash. Make sure ash does not build up to a point where it hinders the air flow.
- Before removal, make sure the fire is completely out and the ashes cool.
- Use a small fireplace shovel to remove accumulated ash.
- Place the ashes in a metal container with tight-fitting lid and store the closed container on a non-combustible floor surface. Keep it well away from all combustible materials until final disposal. Dispose of the ash by burying it in soil or other local dispersal. Make sure ash is retained in the closed container until cinders have thoroughly cooled.
- Replace any grate that has deteriorated, distorted or sagged from extended use.



3-YEAR LIMITED WARRANTY

1. Subject to the following terms, Westlake Royal LLC ("Westlake") warrants to the original purchaser and subsequent owners that for 36 months from the date of sale, its Kindred Outdoor product will perform according to its specifications. This Limited Warranty is not limited to the original purchaser but covers the stone regardless of whether ownership of the building changes. This warranty runs with the transfer of the property to subsequent owners of the property into which the warranted products have been incorporated.
2. This Limited Warranty is not limited to the original purchaser but covers Kindred Outdoor regardless of whether ownership of the premises changes. This warranty runs with the transfer of the property to subsequent owners of the property into which the warranted products have been incorporated, but the warranty period as to such subsequent owners is limited to six (6) months or the remaining life of the 36 month original purchaser warranty from the original date of installation, whichever is longer.
3. Subject to the terms hereof, Westlake warrants Kindred Outdoor to the Purchaser and subsequent owners for a period of THIRTY-SIX (36) MONTHS from the date of sale. In the event that a Kindred Outdoor product is defective, Westlake will, as its sole discretion, either: a) provide a replacement of the defective product or pay the reasonable cost for replacement product of a similar design; or b) pay the reasonable cost for repair of the defective product. THIS WARRANTY DOES NOT COVER LABOR TO REMOVE OR REPLACE THE DEFECTIVE PRODUCT.
4. No warranty whatsoever is made with respect to the manufacture or performance of materials or components of construction not sold or manufactured by Westlake, including but not limited to all installation components including but not limited to, mortar, lath, weather resistant barriers, doors, windows, sealants, flashings, roofing, copings, sheathing and framing. Further, Westlake makes no warranties whatsoever with respect to aesthetics, design and engineering of the structure into which Westlake products are incorporated, or workmanship involved in the application of any Westlake products warranted hereunder. The Westlake product is not waterproof. The Westlake product must be incorporated into a cladding designed by a building professional that contains adequate mechanisms for water management. Westlake has no responsibility for damage caused by moisture intrusion through the building envelope or around any of the building envelope components or by vapor transmission from the inside of the building to a moisture sensitive part of the wall assembly.
5. Without limiting anything else in this document, Westlake disclaims and assumes no liability for:
 - 5.1 improper use, application or installation of Westlake products,
 - 5.2 use of Westlake products as part of improperly designed or constructed assemblies or buildings or with defective adjacent materials or assemblies;
 - 5.3 failure to follow applicable specifications, instructions and construction details;
 - 5.4 other design or construction defects, deficiencies and failures on a building where Westlake product is used;
 - 5.5 undertaking on-site inspections or any on-site activities or making oral statements made at the site;
 - 5.6 any damage or injury whatsoever caused in whole or in part by acts of God, natural phenomenon or physical abuse such as but not limited to falling objects, projectiles, fire, earthquake, floods, windstorm, hail, tornadoes, lightning, hurricanes, other abnormal weather conditions, pests, chemical fumes, foreign substances in the air, misuse, vandalism, civil disobedience, war, damage caused by remodeling or renovation;
 - 5.7 damage resulting from moisture intrusion, mold, settlement of building or other building or wall movement;
 - 5.8 discoloration or deterioration due to airborne contaminants; or contact with any chemicals or paint; staining or oxidations;
 - 5.9 any accumulation of water or moisture in wall assemblies;
 - 5.10 negligence or accidents by any party or parties in maintaining the Westlake materials including but not limited to use of pressure washer to clean;
 - 5.11 replacement of Kindred Outdoor if Westlake product is mixed with other chemicals or materials not approved by Westlake in writing;
 - 5.12 any cause beyond Westlake's control; and
 - 5.13 any workmanship, aesthetics or other damage or injury not solely and directly caused by a manufacturing defect in Westlake's products as covered under this warranty.



3-YEAR LIMITED WARRANTY Continued

6. THIS LIMITED EXPRESS WARRANTY IS EXCLUSIVE, THE ONLY WARRANTY MADE BY WESTLAKE, AND IS IN LIEU OF ALL OTHER WARRANTIES OR REMEDIES OF ANY NATURE WHATSOEVER TO THE ORIGINAL OR SUBSEQUENT PURCHASERS OR USERS UNDER ANY THEORY OF LIABILITY, WHETHER IN CONTRACT, TORT, STATUTORY LAW OR OTHERWISE, EXCEPT FOR ACTUAL ECONOMIC DAMAGES FOR PERSONAL PHYSICAL BODILY INJURY. ALL OTHER WARRANTIES, REPRESENTATIONS OR REMEDIES, WHETHER ORAL, WRITTEN, EXPRESS OR IMPLIED OR IMPOSED BY LAW ARE DISCLAIMED BY WESTLAKE AND ARE WAIVED BY THE PURCHASER, PARTICULARLY THE IMPLIED WARRANTIES OF MERCHANTABILITY OR FITNESS FOR A PARTICULAR PURPOSE OR ARISING FROM A COURSE OF DEALING, USAGE OR TRADE PRACTICE, OR ANY WARRANTY AGAINST PATENT INFRINGEMENT OR WARRANTY FOR WORK PERFORMED IN A WORKMANLIKE MANNER. WESTLAKE SHALL NOT BE LIABLE UNDER ANY CIRCUMSTANCES FOR ANY INCIDENTAL, SPECIAL, INDIRECT OR PUNITIVE DAMAGES TO ANY PARTY WHATSOEVER, INCLUDING BUT NOT LIMITED TO, LOSS OF PROFITS OR DAMAGE TO THE BUILDING OR ITS CONTENTS, ATTORNEY'S FEES. THIS EXCLUSION OF DAMAGES INCLUDES, BUT IS NOT LIMITED TO PAYMENTS OF ANY NATURE MADE BECAUSE OF ACTUAL OR POTENTIAL LIABILITY TO OTHERS, DAMAGES TO ANY OTHER PART OF THE STRUCTURE TO WHICH THE WARRANTED PRODUCTS ARE INCORPORATED OR DAMAGE TO ANY OTHER PROPERTY.
7. Any complaints regarding appearance or cosmetic effect, including but not limited to color, tint, hue, shading, grain, texture, finish, color consistency, chipping, staining, or non-structural cracks of products must be conveyed in writing to Westlake by the Purchaser prior to commencing installation. Upon receipt of a written complaint, Westlake will examine its production records and compare them with approved samples and in the event of a manufacturing discrepancy, will provide a remedy in accordance with the provisions of this Warranty. Westlake shall have a minimum period of sixty (60) days to investigate any complaint.
8. This limited warranty is exclusive and is in lieu of all other warranties or remedies at law or in equity. All other warranties, representations, or remedies, whether oral, written, express, implied, or imposed by law are disclaimed by Westlake and waived by the Purchaser and any subsequent owner. Westlake expressly disclaims any warranty of merchantability or fitness for a particular purpose, or any warranties arising from a course of dealing, usage or trade practice, or any warranty against patent infringement or warranty for work performed in a workmanlike manner. Oral statements by Westlake employees or agents do not constitute warranties, shall not be relied upon by the Purchaser or any third party, and are not part of the contract for sale or warranty stated herein. WESTLAKE SHALL NOT BE LIABLE FOR ANY INCIDENTAL, SPECIAL, CONSEQUENTIAL, OR PUNITIVE DAMAGES, INCLUDING BUT NOT LIMITED TO LOSS OF PROFITS OR ATTORNEYS' FEES.
9. This Warranty shall be construed and interpreted under the laws of New York. Any provision of this warranty that is prohibited or unenforceable in any jurisdiction shall, as to that jurisdiction only, be ineffective to the extent of such prohibition or unenforceability without invalidating the remaining provisions hereof or affecting the validity of enforceability of such provision in any other jurisdiction. Any applicability of the Magnusson-Moss Act is hereby disclaimed. Westlake's failure at any time to enforce any of the terms or conditions stated herein shall not be construed to be a waiver of such provisions.



KINDRED

OUTDOORS + SURROUNDS