

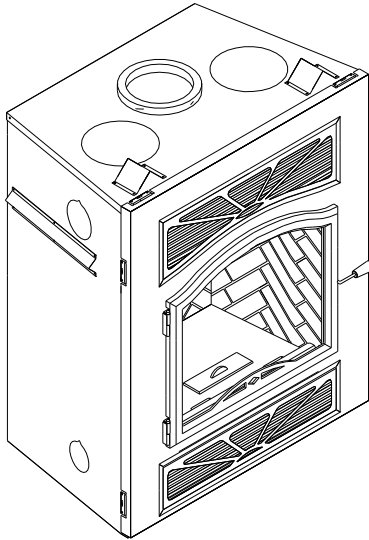

INSTALLATION AND OPERATION INSTRUCTIONS



WRT4826

Wood Burning Fireplaces
P/N 901002-00 REV. NC 07/2019

MODEL

WRT4826WH

SAVE THESE INSTRUCTIONS FOR FUTURE REFERENCE

A French manual is available upon request. Order P/N 901002-02.

Ce manuel d'installation est disponible en français, simplement en faire la demande.
Numéro de la pièce 901002-02.

This installation manual will enable you to obtain a safe, efficient and dependable installation of your fireplace system. Please read and understand these instructions before beginning your installation.

Do not alter or modify the fireplace or its components under any circumstances. Any modification or alteration of the fireplace system, including but not limited to the fireplace, chimney components and accessories, may void the warranty, listings and approvals of this system and could result in an unsafe and potentially dangerous installation.

IHP wood-burning fireplaces are designed for use as a supplemental heater. They are not intended for continuous use as a primary heat source.

	! WARNING
	<ul style="list-style-type: none"> • Hot! Do not touch! The glass and surfaces of this appliance will be hot during operation and will retain heat for a while after shutting off the appliance. Severe burns may result. • Carefully supervise children in the same room as appliance.
<ul style="list-style-type: none"> • If small children are present in the home, it is recommended that this appliance be fitted with an adjustable safety gate or barrier screen. 	

! WARNING
<ul style="list-style-type: none"> • The fireplace cannot be operated without a door. Consult your dealer to select the correct door. • Important! To assure proper alignment of glass doors: Install this fireplace in a square and plumb condition, using shims as necessary at sides and/or bottom. • Install the fireplace only as described in these instructions.

	<p>Listed to standards: ULC-S610 & UL-127 Report # 14-197 EPA Cert. No. 518</p>
--	-------------------------------------------------------------------------------------------------

! WARNING
<p>This product can expose you to chemicals including Carbon Black, which is known to the State of California to cause cancer, and Carbon Monoxide, which is known to the State of California to cause birth defects or other reproductive harm. For more information go to www.P65Warnings.ca.gov</p>



CONGRATULATIONS!

When you purchased your new fireplace, you joined the ranks of thousands of individuals whose answer to their home heating needs reflects their concern for aesthetics, efficiency and our environment. We extend our continued support to help you achieve the maximum benefit and enjoyment available from your new fireplace.

Thank you for selecting a IHP fireplace as the answer to your home supplemental heating needs.

TABLE OF CONTENTS

The Fireplace.....	Page 2
Introduction	Page 2
Parts Required	Page 2
Additional Equipment (Optional)	Page 2
Safety Rules.....	Page 3
Operating The Fireplace	Page 4
Fuel	Page 4
Catalytic Combustor.....	Page 4
Combustion Control	Page 4
Starting And Maintaining A Fire	Page 5
Refuelling For Best Performance	Page 5
Smoking – Causes And Troubleshooting.....	Page 6
Important Cautions	Page 6
Dealing With A Chimney Fire.....	Page 6
Maintaining Your Fireplace	Page 7
Creosote.....	Page 7
Chimney Maintenance.....	Page 7
Catalytic Combustor.....	Page 7
Refractory Replacement.....	Page 10
Door Frame Care.....	Page 10
Ashes	Page 10
Door Installation	Page 11
Door Adjustment.....	Page 11
Glass Care - Replacement.....	Page 11
Glass Care - Cleaning.....	Page 11
Gasket Replacement	Page 11
FIREPLACE INSTALLATION	Page 11
Locating The Fireplace	Page 11
Framing, Facing And Mantel.....	Page 12
Hearth Extension Requirements	Page 12
Cold Climate Installations.....	Page 12
Fireplace / Framing Dimensions.....	Page 13
Insulated Chase Construction	Page 14
Nailing Flanges.....	Page 14
Facing / Mantel	Page 15
Outside Air Kit	Page 16
Draft Requirements.....	Page 16
Heatflow Convection Kit Installation...	Page 17
Chimney System	Page 20
Chimney Installation Instructions Using IHP Snap Pak (USA)	Page 21
Chimney Installation Instructions Using Security ASHT (Canada)	Page 25
Chimney Chase And Multiple Terminations.....	Page 25
Masonry Applications	Page 26
Installation Accessories	Page 27
Replacement Parts.....	Page 28
Specifications.....	Page 28
Clearance To Combustible	Page 28
Security Chimney Components Lists.....	Page 29
Safety/Listing Label.....	Page 30
Warranty	Page 31
Product Reference Information.....	Page 32

THE FIREPLACE

INTRODUCTION

The WRT4826WH wood-burning fireplace is an energy efficient, heat circulating, closed combustion fireplace. You will receive a lifetime of comfort and enjoyment from your fireplace provided it is installed, maintained and operated properly.

- Please read these instructions and retain this manual for future reference.
- Before beginning the fireplace installation, consult the appropriate local authorities to obtain your building permit and check your local building codes. Install the fireplace only as described in these instructions and using only IHP components.
- This fireplace has been tested for CAN/ULC S610-M87 and ANSI/UL 127. It has also been tested for EPA 40 C.F.R Part 60, section 60.532(b).
- The WRT4826WH fireplace is not intended for use with a gas log set. Do not use a fireplace insert or any other product with this fireplace unless it is specified by IHP for use with this appliance. Failure to follow these instructions will void the certification and the warranty of the fireplace and may result in an unsafe installation.
- These appliances are designed to provide supplemental heat to the immediate area only. Therefore, it is advisable to have an alternate heat source when installed in a dwelling.
- These appliances are not approved for Manufactured Home installations.

CAUTION: BURN UNTREATED WOOD ONLY. OTHER MATERIALS SUCH AS WOOD PRESERVATIVES, METAL FOILS, COAL, PLASTIC, GARBAGE, SULPHUR OR OIL MAY DAMAGE THE CATALYST.

CAUTION: DO NOT OPERATE WITHOUT THE CATALYTIC COMBUSTOR IN PLACE.

CAUTION: NEVER BURN WITH THE BY-PASS OPENED EXCEPT FOR FIRE START-UP AND WHEN RELOADING THE STOVE.

PARTS REQUIRED

Fireplace model: WRT4826WH

- Louver set (*See options on Page 22*)
- **7" diameter chimney - United States**

Model IHP Snap-Pak, including:

- Chimney lengths
- Elbows (where necessary)
- Associated components as per these installation instructions and vent manufacturer's instructions.

- **7" diameter chimney - Canada**

Models ASHT® & S2100 manufacture by Security Chimneys® or DuraTech Canada (DTC) manufactured by DuraVent only, including:

- Chimney lengths
- Elbows (where necessary)
- Associated components as per these installation instructions and vent manufacturer's instructions.

- Outside air kit (included)

Additional Equipment (optional)

- Forced Air Kit
- Heatflow Convection Kit
- Fireplace Blower Kit, UZY5

IMPORTANT! GENERAL SAFETY PRECAUTIONS. READ AND UNDERSTAND THESE SAFETY RULES BEFORE YOUR FIRST FIRE.

! WARNING

The WRT4826WH fireplace must be installed with an outside air kit intake, which is included with the fireplace

! WARNING

THE FIREPLACE MUST BE OPERATED WITH THE DOORS FULLY OPENED OR DOORS FULLY CLOSED. IF THE DOORS ARE LEFT PARTLY OPENED, GAS AND FLAME MAY BE DRAWN OUT OF THE FIREPLACE OPENING, CREATING RISKS OF BOTH FIRE AND SMOKE. IF THE UNIT IS OPERATED WITH THE DOORS FULLY OPENED, THE FIRE SCREEN MUST BE USED.

! WARNING

NEVER use gasoline, gasoline-type lantern fuel, kerosene, charcoal lighter fluid, naphtha, engine oil or similar liquids to start or "freshen up" a fire in this fireplace. Keep any flammable liquids a safe distance from the fireplace at all times.

! WARNING

THIS FIREPLACE HAS NOT BEEN TESTED WITH AN UNVENTED GAS OR A FIREPLACE INSERT. TO REDUCE RISK OF FIRE OR INJURY, DO NOT INSTALL AN UNVENTED GAS LOG SET OR FIREPLACE INSERT OR OTHER PRODUCTS NOT SPECIFIED FOR USE WITH THIS FIREPLACE.

! WARNING

Never leave your fireplace unattended while it is burning.

! WARNING

Use care when selecting window treatments for windows located near the fireplace. Avoid using combustible flowing window treatments such as curtains on nearby windows that are of sufficient length to be blown in front of an open flame when the window is opened.

Keep any combustible furniture, materials or decorative pillows at least 48" (1219 mm) from the front fireplace opening.

! WARNING

Never leave children unattended when there is a fire burning in the fireplace.

! IMPORTANT

When burning wood, use SOLID NATURAL DRY WELL-SEASONED WOOD ONLY. Hardwoods are recommended (soft woods tend to burn very quickly).

- DO NOT burn treated wood, charcoal, coal, trash, cardboard, driftwood, woods dipped in tar, Christmas tree greens, pitch, pine tar, creosote, chemical chimney cleaners, flame colorants, polystyrene packaging, wood products with synthetic binders (i.e. plywood). Plywood, lumber and other misc. materials can produce abnormally high temperatures, sputtering and smoking fires and may contain hazardous chemicals to treat insects and fungus.
- Burning unapproved fuels can produce excessive temperatures, beyond the design capabilities of the fireplace and may produce excess sparks or may contain hazardous chemicals. Burning unapproved fuels can result in a chimney fire, a house fire, personal injury, death or loss of property.

! WARNING

To avoid the risk of damaging fireplace materials and increasing the risk of fire, do not use the fireplace to cook or warm food.

! WARNING

Be careful adding wood fuel to the fire or handling fireplace tools such as shovels, tongs or pokers.

! WARNING

Never modify or alter your fireplace system in any way. To do so may create a potential fire hazard and void the limited warranty, listings and approvals of this system.

! WARNING

The bottom refractory can be cracked by excessive abuse such as tossing heavy logs onto the grate or gouging with fireplace tools. Exercise caution when adding wood to your fireplace.

! WARNING

Neither the manufacturer nor the seller warrants "smoke free" operation nor are we responsible for inadequate system draft caused by mechanical systems, general construction conditions, inadequate chimney heights, adverse wind conditions and/or unusual environmental factors or conditions beyond our control.

! WARNING

Always ensure that the air inlet to the fireplace is free from debris and any other obstructions that can block the entrance of air.

OPERATING THE FIREPLACE

Fuel - This appliance is designed to burn dry seasoned natural wood only (see Page 7 for a list of prohibited fuels). Failure to burn proper fuels only will void the certification and the warranty of the appliance. Hardwoods are preferred to softwoods since the energy content of wood is relative to its density. Hardwoods will result in a longer burning fire and less frequent refuelling.

A moisture content of 15% to 20% (seasoned) is recommended. Wood that has been cut and split and let to dry under a cover for a period of one year will usually meet that criteria. The required drying time will vary depending on the climate. Wood that is packed tight together will take longer to dry. Seasoned wood is darker in color than wet wood and will have visible cracks in the grain on the ends. Excessively wet wood will be difficult to burn and will result in lower efficiency, increased creosoting and plugging of the catalytic combustor. Excessively dry wood will burn well but will also have higher emissions and shorter burning time.

Overheating the unit above 1000° C (1800° F) is harmful for the catalytic combustor, it can damage the catalyst coating and can cause cracking of the substrate. Looking through the upper louvers, if the top of the firebox is glowing, the unit is overheating.

DO NOT OVERFIRE THIS HEATER

Attempts to achieve heat output rates that exceed heater design specifications can result in permanent damage to the heater and to the catalytic combustor if so equipped.

First Fires

The first 5 or 6 fires should be small fires of short duration (about 30 to 60 minutes). This will help cure the refractory bricks. Ashes that will accumulate in the ashtray will protect it from intense heat. During the first few fires of this appliance there may be some odor and smoke due to the curing of the paint, dust accumulation and burning off of lubricants used in the manufacturing process. It may set off a smoke alarm located in the same room. For this reason the room should be well ventilated for the first few fires.

Catalytic Combustor

These fireplaces are equipped with a catalytic combustor. Unburned by-products of the wood fire are burned at lower temperatures as they pass through the combustor resulting in less pollution, reduced creosote and higher efficiency. In order to have the catalyst working, temperatures of the flue gases entering the combustor have to be higher than 500° F (260° C). That is why the unit is equipped with a by-pass damper that allows the draft air to by-pass the catalytic combustor. Opening the by-pass damper control increases the draft allowing the unit to achieve proper operating temperatures during a cold start-up. It also provides more draft to prevent smoke spillage when the door is opened.

Catalytic By-Pass Gauge

To determine when to close the By-Pass, the unit is equipped with a gauge (see **Figure 1**). The gauge is located behind the bottom louver in the lower left corner. To open the louver, gently pull underneath the top fin of the louver and the door will open down. Once you can see the gauge needle in the catalytic combustor operating range, you may push to close the By-Pass lever and close the bottom louver.

When the catalyst light-off conditions are achieved, the combustor will keep on going until it runs out of smoke. Note that the catalyst does not need to be glowing to be working, it can work very well at temperatures well below the 538° C (1000° F) level at which it will begin to glow. The best way to see if the catalyst is active is to take a look at what is coming out of the chimney. If the catalytic combustor is working you will see some white water vapor coming out, compared to a more brown/gray smoke when the by-pass is opened. Do not burn any chemical chimney cleaner; it can make the catalyst inactive.

Combustion Control

There is no flue damper in this fireplace. As is common with air tight appliances, the combustion air damper controls the air entering the firebox. This allows for a more precise control of the fire. The combustion air damper knob is located on the left of the bottom louver (**Figure 1**). It is opened when moved completely to the left. This control should be in the closed position when the fireplace is not in use. This will minimize air leakage up the chimney. **The combustion air control and the by-pass damper control must be opened before opening the door to minimize the possibility of back draft coming into the room.**

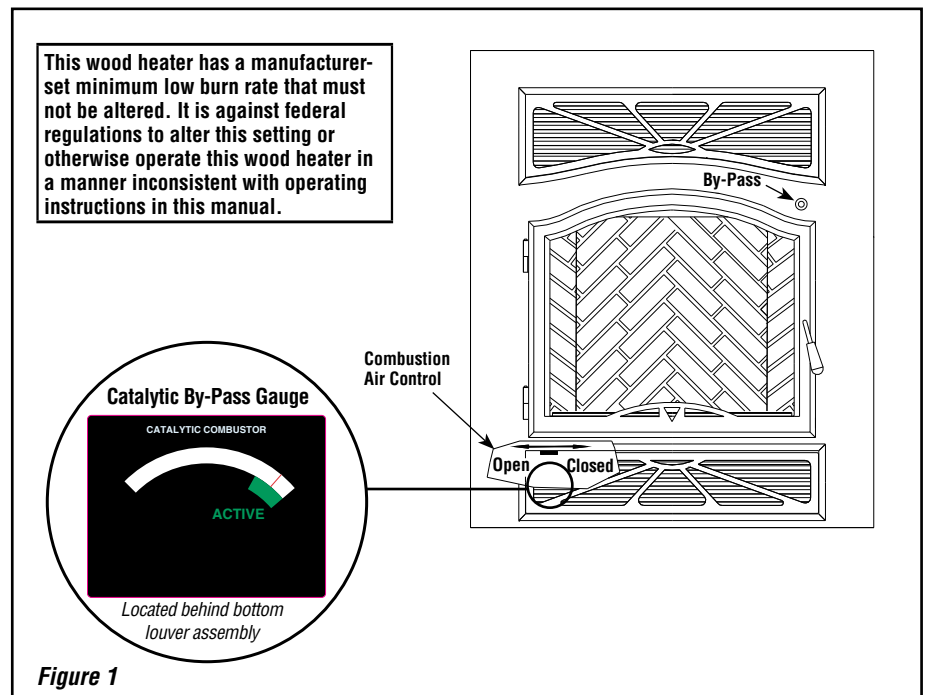

This manual describes the installation and operation of the IHP model WRT4826WH catalytic equipped wood heaters. This heater meets the 2015 U.S. Environmental Protection Agency's crib wood emission limits for wood heaters sold after May 15, 2015. Under specific test conditions this heater has been shown to deliver heat at rates ranging from 10,900 to 35,600 Btu/hr.

Accelerated Combustion

The maximum heat output for the fireplace is achieved by burning with the combustion air damper opened (see **Figure 2**). By this method, the fireplace can produce up to 70,000 BTU of heat per hour. However, it will be necessary to reload with wood every one or two hours. This is the least efficient method of burning the fireplaces.

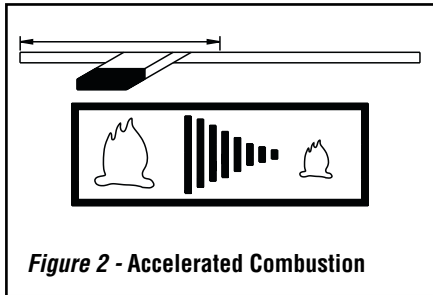

Use caution when firing with the combustion air control wide open. Only burn cordwood in this manner. Small dry pieces of softwood and construction scraps will burn very intensely using this method and may damage the firebox and catalytic combustor.

Medium Combustion

This is the recommended mode of operating the fireplaces and should be the one normally used since it will deposit the least amount of creosote on the glass and in the chimney. The combustion air damper must be 3/4" closed (see **Figure 3**). The precise setting will depend on many factors, including chimney length and the moisture content of the wood.

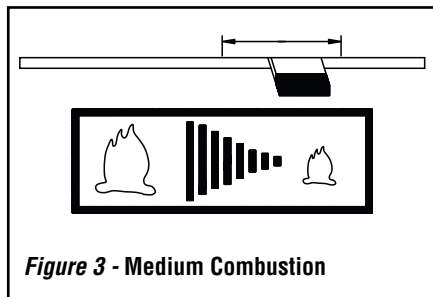

For instance, a long chimney will necessitate closing the damper more. To obtain the proper combustion, close the damper completely, then open it about 1/2 to 3/4. Three medium size pieces of wood should be burning on a bed of hot coals. The heat output will be approximately 35,000 BTU per hour and the loading time will be about every 3-4 hours. Softwoods may be burned using this method but the time will be substantially reduced.

Slow Combustion

When the air combustion damper is almost closed, the fireplace is in a slow combustion phase (see **Figure 4**). Slow combustion will not stop the fire, but there will be a noticeable change in the flame pattern. The flames will be slow and may appear dirty if the wood is too wet (moisture content of 20% and more). **Always set the damper so that flames are visible, that way you maintain a good clean combustion process.**

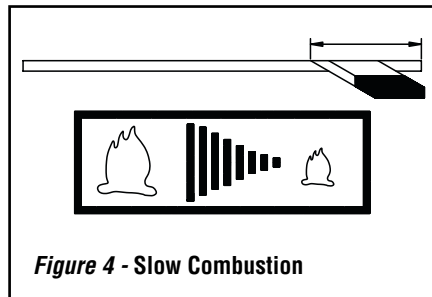

This method of burning should be used only after operating the fireplace with the air control opened to produce a hot fire for about an hour. Slow combustion can be used at night in order to reduce the heat output and prolong the burn. The loading time will be between 6-10 hours. **Be aware that the glass will get dirty using this setting.**

Starting And Maintaining a Fire

Step 1. Place several crumpled up balls of newspaper in the firebox. Place small dry pieces of kindling on top of the paper, criss-crossing the kindling so that there are air spaces in between. Keep the fuel far back enough so that air can get underneath.

Step 2. Open the air control fully and pull the by-pass damper control towards you to put it in the OPEN position. Light the newspaper. Leave the door open until the fire is well established.

Step 3. Once the kindling fire is well established, add increasingly larger pieces of cordwood until the fire is actively burning. Close the door and maintain an accelerated combustion air set up in order to achieve combustor light-off conditions.

Step 4. When the fire is burning well, close the by-pass damper control by pushing the control rod in. It takes about 15 – 30 minutes with the by-pass opened to reach proper light-off temperatures for the catalytic combustor.

Step 5. Set the air control at the desired setting.

The unit will burn best with 2-3 pieces of cordwood spaced 1 to 2 inches apart and allowing air to get under the fuel. Criss-crossing or arranging the fuel so that air can get underneath, will help the fire get started easily.

Refuelling for Best Performance (see **Figure 5**)

To refuel the fireplace at the end of a burn cycle when only hot embers remain and flames are gone (not enough heat to maintain catalyst operating temperatures):

Step 1. Open the by-pass and air controls fully.

Step 2. Open the door approximately 1 inch and wait five seconds until the draft is stable. Then open the door completely, load the fuel and close the door.

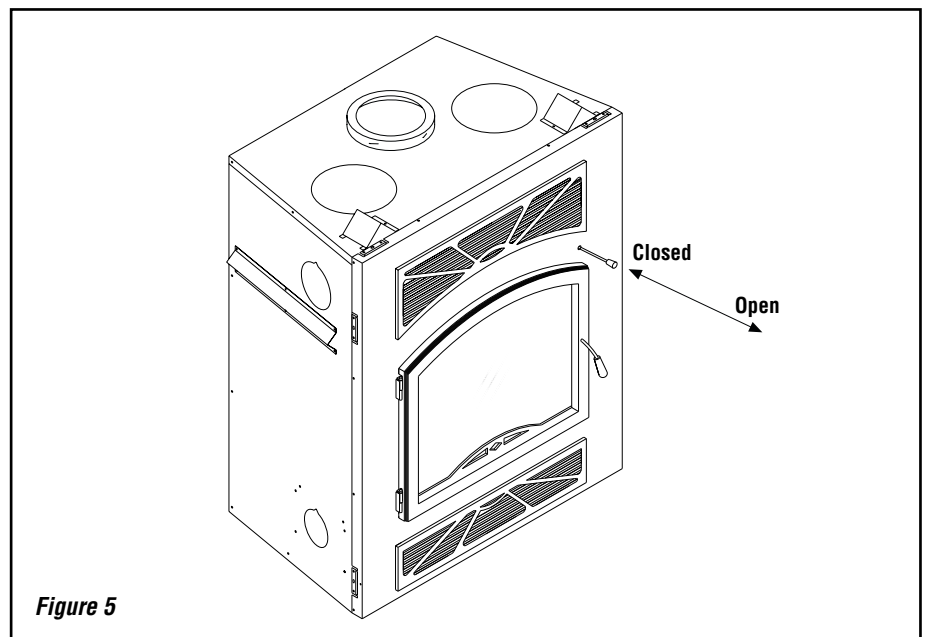

Step 3. Keep the combustion air damper and the by-pass damper opened for 10 minutes before closing it. It will ensure sufficient temperatures for combustor light-off.

To refuel the fireplace when the unit is still hot (Some burning fuel remaining or a glowing combustor)

Step 1. Open the by-pass and air controls fully.

Step 2. Open the door approximately 1 inch, wait five seconds until the draft is stable and then open it completely. Load the fuel, close the door and by-pass (temperatures within the firebox should be enough to maintain catalytic operation).

REFUELING: During the refueling and rekindling of a cool fire, or a fire that has burned down to the charcoal phase, operate the stove at a medium to high firing rate for about 10 minutes to ensure that the catalyst reaches approximately 600°F.

Smoking – Causes and Troubleshooting

To reduce the likelihood of smoking when opening the doors, set the air damper to the “accelerated combustion” position and open the by-pass damper before opening the doors. Your fireplace has been designed and tested to provide smoke free operation. Occasionally, there may be a small amount of smoking upon lighting the fire, until the chimney heats up but this should not continue. If the fireplace does continue to smoke, it is probably for one of the following reasons:

- A. The door is partly open** - Open the door fully.
- B. Negative pressure in the house** - As the fire burns, air goes up the chimney. This air must be replaced through leakage into the house or through the outside air duct. When operating the fireplace, open a nearby window temporarily to check if there is adequate air replacement.
- C. Fans operating (e.g. range hood)** - These fans draw air out of the house and may actually cause a negative pressure in the house. Turn off all fans and open a nearby window to determine if this is the cause of the problem.
- D. Wet wood** - Wet or tarred wood will smoulder and smoke instead of burn properly. Your dealer can help you determine if you have properly seasoned wood for burning.
- E. Dirty or blocked chimney** - Check to make sure the chimney is clear and reasonably clean. If dirty call a certified chimney sweep or use a properly sized chimney brush to clean.
- F. Chimney not long enough** - The minimum chimney height is 12 feet, not including the fireplace height. The chimney must extend at least 3 feet (915 mm) above its point of contact with the roof and at least 2 feet (610 mm) higher than any roof or wall within 10 feet (3 m) of it.

G. Poor chimney draft - With no fire, there should be sufficient draft to exhaust cigarette smoke introduced under the baffle. Chimneys installed against an outside wall without protection may generate backdraft problems which will cause start-up problems. To prevent this, open a nearby window, roll up a piece of paper and light it.

Then, hold it in the upper part of the firebox to warm up the chimney. Wait until the draft is sufficient, then start the fire.

H. Blower for forced air kit operating - Make sure that the blower is at the “off” position when you open the fireplace door for reloading.

IMPORTANT CAUTIONS

- A. Do not block the hot air vents to the fireplace as this will cause the fireplace to overheat.**
- B. Never use gasoline, gasoline-type lantern fuel, kerosene, charcoal lighter fluid, or similar liquids to start or ‘freshen up’ a fire in this fireplace. Keep all such liquids well away from the fireplace while it is in use.**
- C. Do not burn coal. The sulphur in coal will corrode the firebox and chimney.**
- D. Do not burn driftwood which has been in the ocean or salt water. The salt will corrode the firebox and chimney.**
- E. Do not operate the unit with the door partly open since this may cause smoke to be drawn into the room.**
- F. Do not burn wood in the area in front of the log retainers.**
- G. Do not abuse the unit by burning paper, or cardboard or construction material such as pressed wood, plywood or lumber.**
- H. Do not allow the wood to smoulder or burn without flame, since this will produce excessive creosote in the unit as well as increased particulate emissions.**

Smoke Detectors Recommended

Since there are always several potential sources of fire in any home, we recommend installing smoke detectors. If possible, install the smoke detector in a hallway adjacent to the room (to reduce the possibility of occasional false activation from the heat produced by these appliances). If your local code requires a smoke detector be installed within the same room, you must follow the requirements of your local code. Check with your local building department for requirements in your area.

Carbon Monoxide Monitor Recommended

Carbon Monoxide Poisoning: Early signs of carbon monoxide poisoning are similar to the flu with headaches, dizziness and/or nausea. If you have these signs, obtain fresh air immediately. Some people are more affected by carbon monoxide than others, including pregnant women, people with heart or lung disease or anemia, those under the influence of alcohol, and those at high altitudes.

It is against federal regulations to operate wood heaters in a manner inconsistent with operating instructions in the manual.

Dealing With A Chimney Fire

Regular chimney maintenance and inspection can prevent chimney fires. If you have a chimney fire, follow these steps:

1. Close the fireplace doors and the combustion air damper.
2. Alert your family of the possible danger.
3. If you require assistance, alert your fire department.
4. If possible, use a dry chemical fire extinguisher, baking soda or sand to control the fire. Do not use water as it may cause a dangerous steam explosion.
5. Check outside to ensure that sparks and hot embers coming out of the chimney are not igniting the roof.
6. Do not use the fireplace again until your chimney and fireplace have been inspected by a qualified chimney sweep or a Fire Department Inspector.

Achieving Clean Burns

Check the exhaust in about 15 to 20 minutes (see below). Large amounts of smoke indicate an improper burn setting (either too high or too low). Adjust and recheck in 5 to 10 minutes.

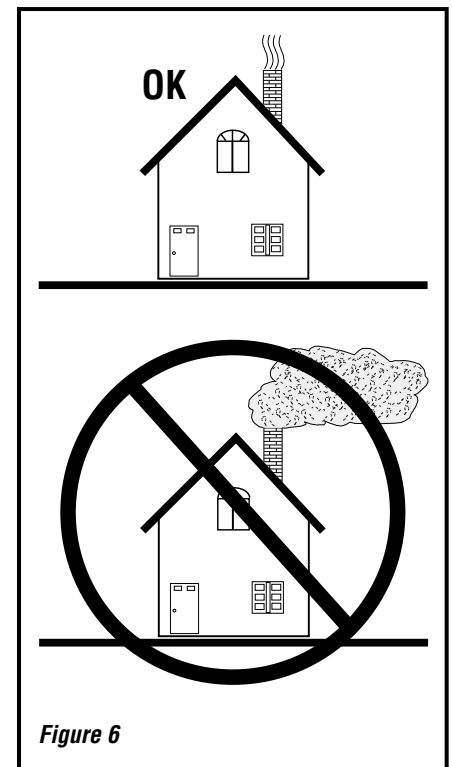

Figure 6

FUEL

What does "Well-Seasoned" mean?

When a tree is cut down, the wood is green, full of sap and moisture. This moisture content can exceed 80%, which must be reduced to less than 20%. Wood properly seasoned is then capable of generating the heat the stove was designed to provide.

Green wood does not burn easily. Attempting to burn green wood often results in a lot of smoke and very little fire. Time is the most important factor in seasoning wood. Ideally the moisture content should be reduced to 11-20%. **NOTE: The use of a firewood moisture meter is recommended to ensure the firewood contains less than 20% moisture.**

Seasoning Guide

Softwoods - 6 months to 18 months
Hardwoods - 12 months to 24 months

Logs that are 5" diameter across or larger should be split in half, three pieces if over 8 inches, and four pieces when over a foot across. If a tree has been dead for 2 - 4 years it still needs to be cut, split, and seasoned for 6 to 24 months depending on the wood.

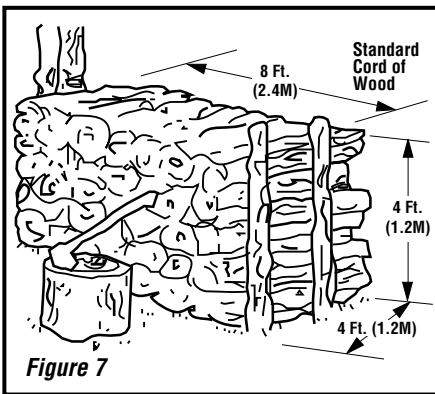

Prohibited Fuels

This heater is designed to burn natural wood only. Higher efficiencies and lower emissions generally result when burning air dried seasoned hardwoods, as compared to softwoods or to green or freshly cut hardwoods. **DO NOT BURN:**

- Garbage;
- Lawn clippings or yard waste;
- Materials containing rubber, including tires;
- Materials containing plastic;
- Waste petroleum products, paints or paint thinners, or asphalt products;
- Materials containing asbestos;
- Construction or demolition debris;
- Railroad ties or pressure-treated wood;
- Manure or animal remains;
- Salt water driftwood or other previously salt water saturated materials;
- Unseasoned wood;
- Christmas tree branches;
- Paper products, colored paper, cardboard, plywood, or particleboard;
- gasoline;

- naphtha;
- engine oil;
- flammable liquids;
- solvents;
- grease; or
- coal

The prohibition against burning these materials does not prohibit the use of fire starters made from paper, cardboard, saw dust, wax and similar substances for the purpose of starting a fire in an affected wood heater.

Burning these materials may result in release of toxic fumes or render the heater ineffective and cause smoke. Intense firing with these materials may overheat the fireplace, causing damage to the unit, a fire or even possibly igniting a chimney fire if the chimney is creosoted. Burning unapproved fuel, resulting in excessive pollutants being emitted, may be prohibited and subject to a fine or other penalty by the authority having jurisdiction in your area.

MAINTAINING YOUR FIREPLACE

Have your product inspected at least once a year by a qualified service technician to ensure gaskets, air tubes, baffles, and venting are in good repair to ensure proper performance. Have degraded items replaced by a qualified service technician.

This wood heater contains a catalytic combustor, which needs periodic inspection and replacement for proper operation. It is against federal regulations to operate this wood heater in a manner inconsistent with operating instructions in this manual, or if the catalytic element is deactivated or removed.

Creosote

When wood is burned slowly, it produces tar and other organic vapors which combine with expelled moisture to form a black deposit called creosote which accumulates on the flue lining. When ignited, this creosote makes an extremely hot fire. If the creosote accumulation is large, a creosote fire in the chimney can damage the chimney and overheat the surrounding wood framing. Creosote formation in a chimney can be minimized by making small hot fires rather than slow burning, smoldering fires and by proper refuelling techniques.

Chimney Maintenance

Regular chimney inspection and maintenance combined with proper operation will prevent chimney fires. Keep your chimney clean. Do not allow more than 1/16" creosote build up in your chimney. The amount of creosote will depend on variables such as frequency of use and type of fire. We recommend that you:

1. Initially inspect the chimney system weekly. From this, you will learn how often it will be necessary to clean your chimney.
2. Have your chimney cleaned by a qualified chimney sweep. If you wish to clean it yourself, we recommend using a stiff plastic or non-metallic brush. If a metal brush is used, its size should be slightly smaller than the flue to avoid damaging the chimney. Do not use a brush that will scratch the stainless steel interior of the chimney.
3. Do not expect chemical cleaners to keep your chimney clean. The rain cap can be removed for inspection and/or cleaning of the chimney. Using gloves, firmly grip the lower portion of the rain cap. Turn the cap 1/8 of a turn counter-clockwise and lift it off the chimney.

Before performing chimney sweep, open the by-pass and remove the combustor. Remove dust accumulation after chimney sweep and put the combustor back in place.

Catalytic Combustor

The fireplace is designed with a catalytic combustor which will reduce pollution emissions and creosote build up while improving thermal efficiency. In order to optimize and maintain the combustor performance, it is important to visually check the combustor at least 3 times during the heating season to determine if physical degradation has occurred.

Catalytic combustors require little maintenance. Cleaning the combustor once a year, preferably when your flue system is serviced, is sufficient for most users.

WARNING

To prevent damage to your combustor, do not:

- **Drop the combustor (which is fragile compared to the rest of the unit – so handle with care)**
- **Run water or compressed air through the combustor**
- **Try to clean the combustor with any sharp tool**

The combustor supplied with this heater is a Applied Ceramics, Inc., Long Life Combustor. Consult the catalytic combustor warranty also supplied with this wood heater. Warranty claims should be addressed to:

**Applied Ceramics, Inc.
5555 Pleasantdale Rd
Doraville, GA 30340
Phone # 770-368-8261**

The packaging of the combustor must be robust enough to protect against any shipping damage that may occur.

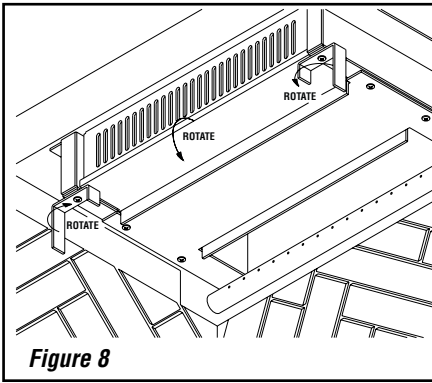

Figure 8

Cleaning Procedure (see Figure 8):

1. Rotate the retainers to release the combustor support plate while holding it to make sure it does not drop.
2. Rotate the support plate and remove the combustor.

3. Remove fly ashes on the combustor using a soft brush.
4. Put the combustor back in place.

Catalyst Monitoring

It is important to periodically monitor the operation of the catalytic combustor to ensure that it is functioning properly and to determine when it needs to be replaced. A non-functioning combustor will result in a loss of heating efficiency, and an increase in creosote and emissions. Following is a list of items that should be checked on a periodic basis:

- Combustors should be visually inspected at least three times during the heating season to determine if physical degradation has occurred. Actual removal of the combustor is not recommended unless more detailed inspection is warranted because of decreased

performance. If any of these conditions exists, refer to Catalyst Troubleshooting section of this owner's manual.

- This catalytic heater is equipped with a temperature probe to monitor catalyst operation. Properly functioning combustors typically maintain temperatures in excess of 500°F, and often reach temperatures in excess of 1,000°F. If catalyst temperatures are not in excess of 500°F, refer to Catalyst Troubleshooting section of this owner's manual.
- You can get an indication of whether the catalyst is working by comparing the amount of smoke leaving the chimney when the smoke is going through the combustor and catalyst light-off has been achieved, to the amount of smoke leaving the chimney when the smoke is not routed through the combustor (bypass mode).

Catalyst Troubleshooting — Problems, Causes and Solutions (see Figure 9, Page 9)		
PROBLEM	POSSIBLE CAUSE	WHAT TO DO
Crumbling Substrate (See Photo #1)	Flame impingement Flames contacting combustor Flame impingement High draft	Reduce air volume to logs; don't overload wood box. Bypass combustor when the appliance is running in high-fire mode. Lower flames by reducing air to logs. Use less logs in the firebox. Do not exceed .06" of water draft. Install a manual damper and draft gauge or a barometric damper.
Fly-Ash Build-up (See Photo #2) Fly-Ash Masking (See Photo #5) Fly-ash Plugging (See Photo #6)	Combustor has not maintained light-off temperature. Combustor has not maintained light-off temperature. Burning materials that produce a lot of char and fly-ash. Closing the bypass too soon.	Brush cold combustor with a soft bristled brush or vacuum lightly. Brush cold combustor with a soft bristled brush or vacuum lightly. Do not burn cardboard, gift wrap or garbage. Follow instructions for proper light-off.
Thermal Cracking (See Photo #3)	Thermal Shock Moisture, wet logs Uneven temperatures and heat spikes. Burning appliance with the door open.	Burn dry, seasoned logs only. If cracking causes large pieces to fall out, replace the combustor. Check appliance for air leaks.
Mechanical Cracks (See Photo #4)	Combustor mishandled or abused. Distortion of combustor holder.	Handle combustor with care. Replace if necessary. Replace combustor if large pieces are missing, replace any warped appliance parts as well. Check appliance for air leaks.
Creosote Plugging (See Photo #7)	Burning wet, pitchy woods or burning large loads of small diameter wood with the combustor in the operating position without light-off ever occurring.	Burn dried seasoned wood. Make sure combustor has light-off before closing the bypass damper. It may be possible to burn the soot or creosote accumulation off by putting the combustor in a partially open and partially closed position after a hot fire has been started. Burn hardwoods.
Masking (Soot) (See Photo #8)	Combustor has not maintained a light-off. Burning coal will cause a sulfur-based compound to coat the catalyst.	Place combustor in a partially open and partially closed position after a hot fire has been started to burn off the soot accumulation. Revert to burning wood and fire the combustor to elevated temperatures for one hour.

Table 1



Photo #1 Crumbling

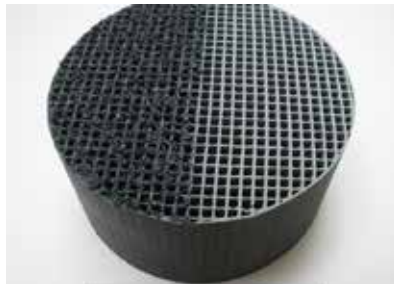

Photo #2 Fly-Ash



Photo #3 Thermal Cracks



Photo #4 Mechanical Cracks



Photo #7 Creosote Plugging



Photo #6 Fly-Ash



Photo #5 Fly-Ash Masking

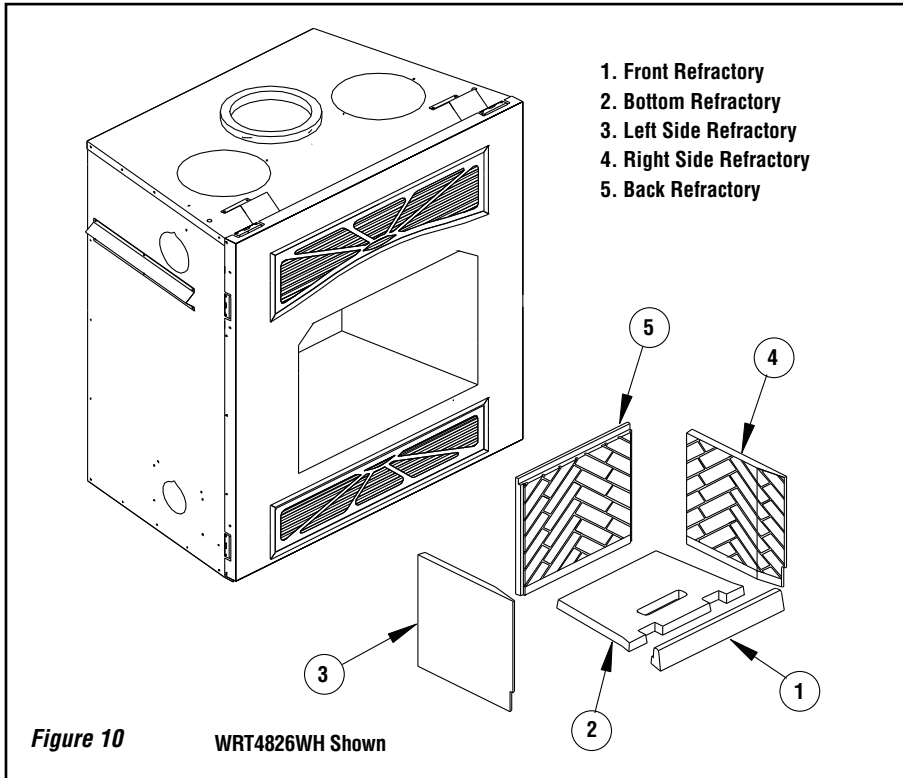

Photo #8 Soot Masking

These conditions are primarily related to such factors as draft, aging or failure of the appliance components, aging or fatigue of the combustor, flue installation, using the wrong fuel or to improper operation of the appliance. Following the appliance's operating manual will prevent these conditions.

Figure 9

Refractory Replacement



The intense heat of the fire will normally cause hairline cracks in the refractory. These cracks can be minimized by proper curing as described in "First Fires". They will not normally diminish the effectiveness of the refractory. If large cracks develop, then the refractory should be replaced. To replace the refractory bricks, follow these steps (see **Figure 10**):

1. Remove the front refractory
2. Remove the bottom refractory
3. Remove the left side refractory
4. Remove the right side refractory
5. Remove the back refractory

To install the new refractories, follow the above steps in reverse.

Door Frame Care

Use a glass cleaner and a soft cloth to polish the frame. Do not use abrasives such as steel wool or steel pads for they may scratch the door frame finish.

Ashes

Whenever ashes get 3 to 4 inches deep in your firebox, and when the fire has burned down and cooled, remove excess ashes. Leave an ash bed approximately 1 inch deep on the firebox bottom to help maintain a hot charcoal bed.

Remove ashes only when the fire is out and the ashes are cold (24 to 48 hours after the fire is out) Open the bottom louver and the doors, lift the door trap lever, remove the plug on the door trap of the ashtray using gloves or a poker. Sweep the ashes in the opening with a brush or any similar tool. Reinstall the plug on the door trap and pull down the lever.

Do not leave the ashes in the house as they give off carbon monoxide and other toxic gases.

WARNING

Disposal of Ashes: Ashes should be placed in a steel container with a tight fitting lid and moved outdoors immediately. The closed container of ashes should be placed on a non-combustible floor or on the ground well away from all combustible materials, pending final disposal. If the ashes are disposed of by burial in soil or otherwise locally dispersed, they should be retained in the closed container until all cinders have thoroughly cooled.

Door Installation

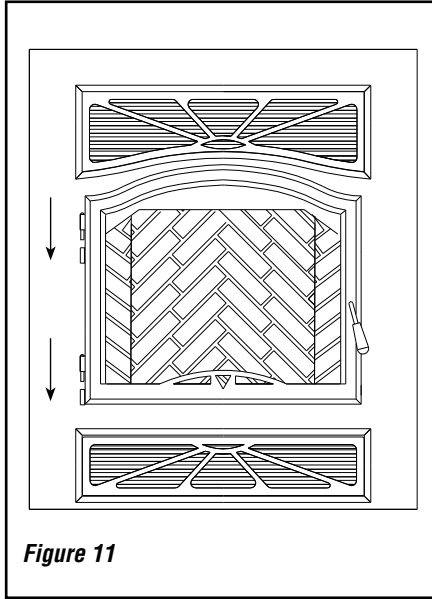

Figure 11

The door must be installed only when the installation of This fireplace is completed. Fit the male part of the hinge, already fixed on the door, in the female part, which is fixed on the fireplace (see **Figure 11**).

To remove the door, simply pull the door up from the hinges.

The adjustment of the door has been set at the factory. If the fit is still not perfect, you can adjust the door using the hinge screws (see **Figure 12**).

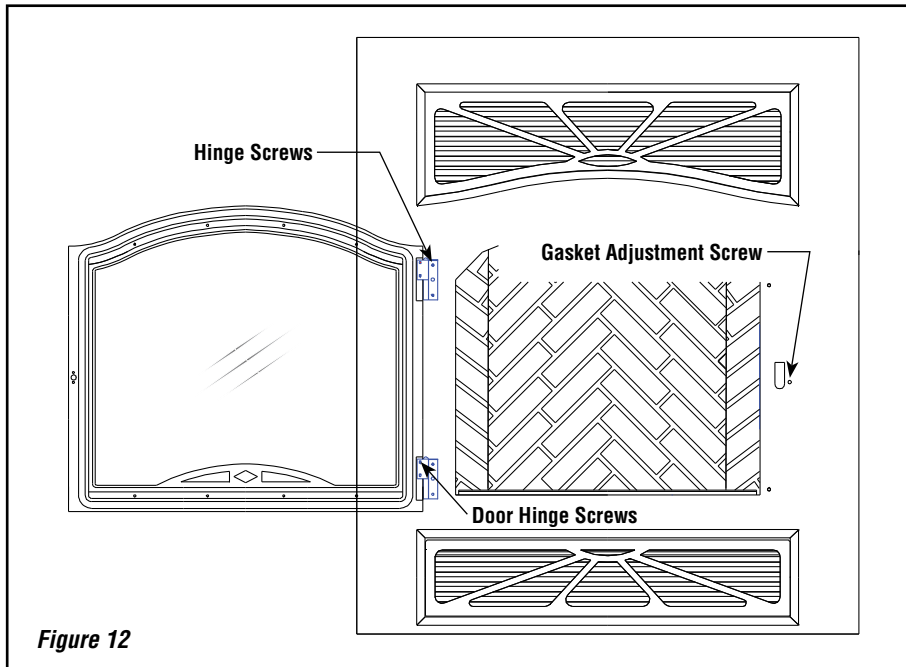

Figure 12

Door Adjustment

The door may need to be adjusted to be completely airtight. The gasket airtightness can be adjusted using the adjustment screw located on the fireplace facade at the bottom of the fireplace opening. (An Allen key # 1/8 will be necessary for adjustment). Turning the screw clockwise will increase air tightness.

Glass Care - Replacement

The glass used for This fireplaces is a high temperature ceramic glass (1,400° F / 760° C). If the glass breaks, it must be replaced with a ceramic glass. Tempered glass or ordinary glass will not withstand the high temperatures of the fireplace. Replacement ceramic glass should be purchased from an IHP dealer. **DO NOT OPERATE THE UNIT WITH CRACKED OR BROKEN GLASS.**

Glass Care - Cleaning

This fireplace is designed to keep the glass clean under normal operating conditions. If This fireplace is operated continuously with the combustion air damper closed, the glass will tend to get dirty unless the fuel, firebox and glass are maintained at hot temperatures (see "Refuelling For Best Performance"). To clean the glass, there are a number of specially designed cleaners. Your IHP dealer can recommend a suitable cleaner which is available in your area. Regular household glass cleaners will not clean creosote. Do not use abrasives such as steel pads, steel wool or oven cleaner as they will scratch the glass.

DO NOT USE CHEMICAL GLASS CLEANERS ON PAINTED SURFACES AS IT MAY CAUSE THE PAINT TO PEEL.

CAUTION: DO NOT ALLOW WINDOW CLEANER TO GET IN CONTACT WITH DOOR GASKET OR PAINT ON FACADE OR DOOR. ONCE CLOSED, CONTACT OF GLASS CLEANER WITH THE FIREPLACE FACADE CAN PROVOKE PAINT PEELING OFF.

Gasket Replacement

Remove the door from the unit and lay it on a clean unabrasive surface. To replace the gasket, first remove all of the old gasket and gasket cement. Make sure that the surface is totally clean before applying new cement or adhesion problems may result. Apply gasket cement to the gasket channel and install the new gasket. This replacement part is available from your IHP dealer in the following dimensions:

Gasket	Length	Dimensions
Around glass	83"	5/16" dia.
On door frame	92"	5/8" dia.
Around ash trap	8"	2" wide x 1/4" thick

FIREPLACE INSTALLATION

Locating the Fireplace

1. The best place to install your fireplace is determined by considering the location of windows, doors, and the traffic flow in the room where the fireplace is to be located, allowing space in front of the unit for the hearth extension and the mantel, and taking into consideration the location of the hot air ducts (optional), outside air kit and chimney. If possible, you should choose a location where the chimney will pass through the house without cutting floor or roof joists (see fireplace dimensions on **Page 13**).
2. Usually, no additional floor support is needed for the fireplace. The adequacy of the floor can be checked by first estimating the weight of the fireplace system. Weights are given on **Page 28**. Note the floor construction and consult your local building code to determine if additional support is needed.
3. A minimum of 7' (2134 mm) measured from the floor to the ceiling is required to install the fireplace. The fireplace can be installed on a combustible floor or on a base, leaving at least 6'8" (2032 mm) from the base of the unit to the ceiling.

Framing, Facing and Mantel

The construction of the framing, facing, and mantel must be in accordance with the standards and the following illustrations:

(see **Figures 13 A/B and 17-19**):

1. Frame the fireplace using 2 x 3 or heavier lumber.
2. **WARNING:** Combustible materials cannot be used in the space directly above the fireplace (except for framing on the front facing). This area must remain empty for **a height of 6'8" (2032 mm) measured from the base of the appliance.**
3. Frame the fireplace with vertical studs at the sides of the fireplace running from floor to ceiling (see **Figure 13**).
If combustible facing is to be used, position the studs back, from the front edge of the fireplace, a space the thickness of the facing material so that the facing can be installed flush with the fireplace facing. Frame headers between the vertical studs only as follows:
 - Place 2 x 3 or 2 x 4 headers, only along the upper part of the front, side and back faces. Do not put wood or any combustible material within the area above the fireplace except on the front facing.
 - Place headers only as required to support the facing and mantel.

The fireplace cannot be in contact with the house insulation material. Cover the insulation with drywall panels or any rigid material around the fireplace.

Hearth Extension Requirements

The fireplace may be installed directly on a combustible floor. The supplied safety metal strip must be positioned as follows: One half under the front of the fireplace and the other half must extend on the floor over which the hearth extension will be built (see **Figure 13A**).

* The safety metal strip must cover the entire width of the fireplace

The combustible floor in front of the fireplace must be covered with a non-combustible material (tile, marble, stone, etc). See **Figure 13B**.

COLD CLIMATE INSTALLATIONS

Climates where temperatures will fall below 32° F (0° C).

The heating performance of the appliance will vary depending upon the level of insulation, house design, how the appliance is operated, etc.

If this fireplace is being installed in a cold climate, it is especially important to seal all cracks around the fireplace and wherever cold air could enter the room with noncombustible material.

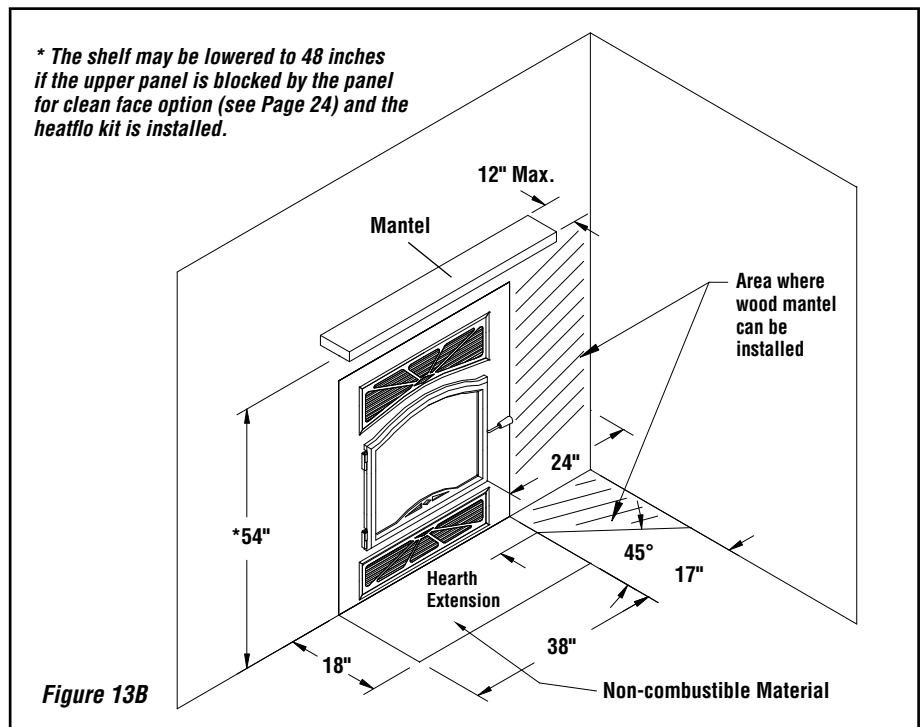
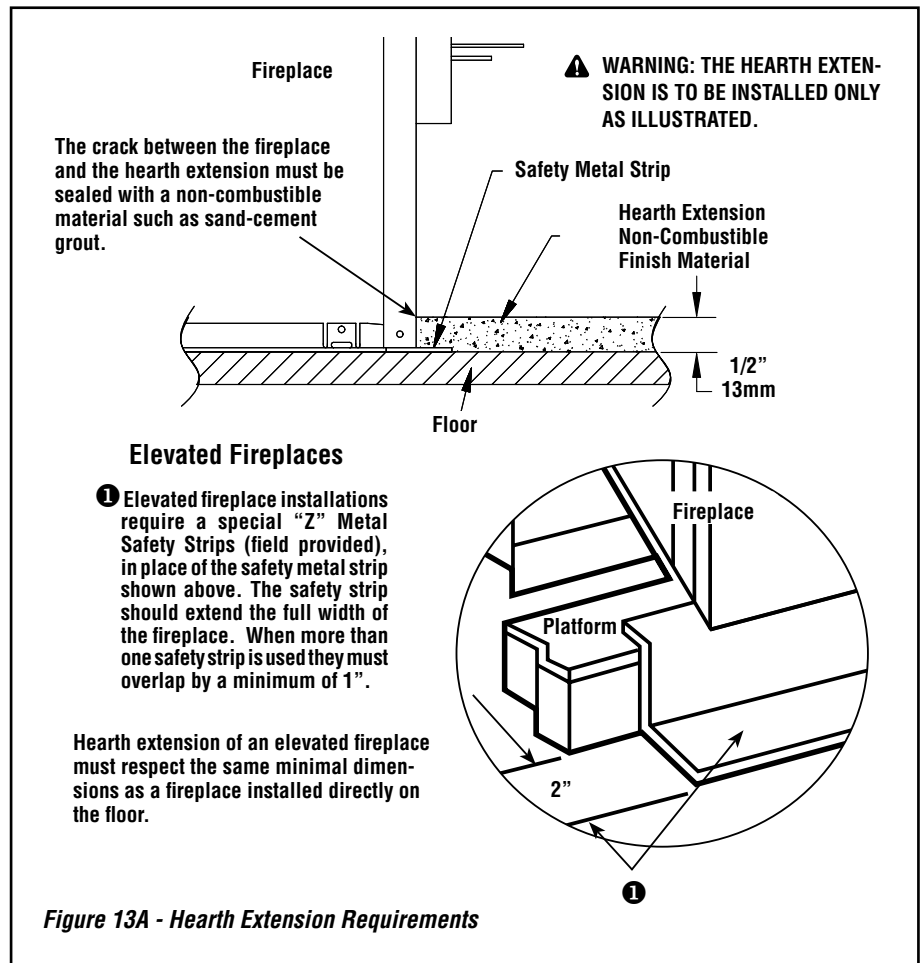

Also, the outside air inlet duct should be wrapped with noncombustible insulation to minimize the formation of condensation. Do not place insulation materials directly against the chimney sections. We recommend that you use the insulated wall radiation shield since it will maintain the home's thermal barrier. AC chimney is NOT recommended in very cold climates (in areas with temperatures below 32°F (0°C).

NOTE: DIAGRAMS & ILLUSTRATIONS ARE NOT TO SCALE.

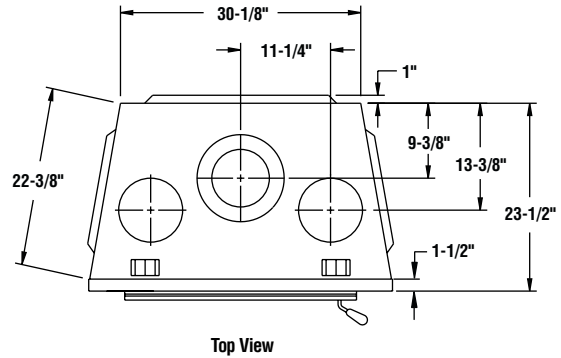
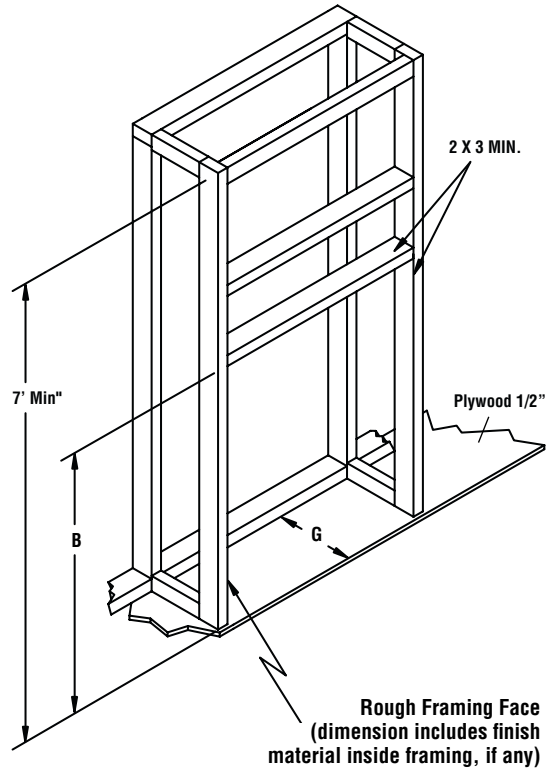
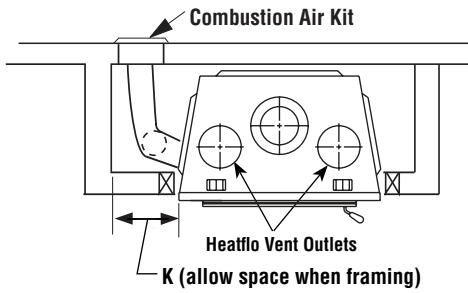
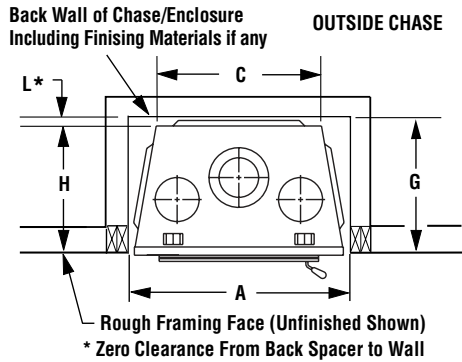
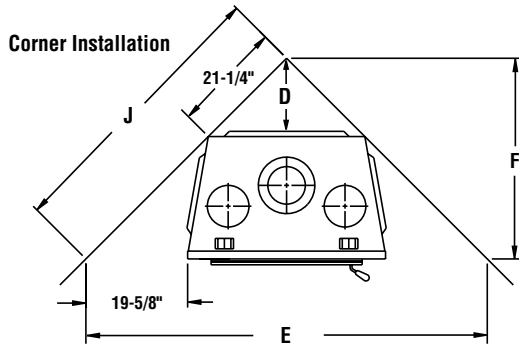

FRAMING DIMENSIONS Fireplace Opening Width		
A	38-1/4"	972 mm
B	47-3/8"	1203 mm
C	30-1/8"	765 mm
D	15-1/8"	384 mm
E	77-1/8"	1959 mm
F	38-5/8"	981 mm
G	24"	610 mm
H	23"	504 mm
J	54-1/2"	1384 mm
K	8"	203 mm
L	1"	26mm

Notes

Diagrams, illustrations and photographs are not to scale - consult installation instructions. Product designs, materials, dimensions, specifications, colors and prices are subject to change or discontinuance without notice.

All framing dimensions calculated for 1/2" dry wall at the fireplace face. If sheathing the chase or finishing with other thickness materials, calculations will need to be made.

* The fireplace must not be in contact with any insulation or loose filling material. Cover the insulation with Drywall panels around the fireplace.

Combustible materials can NOT be used in the space directly above the fireplace. Do not fill the space above the fireplace with any material (Except the wood framing)

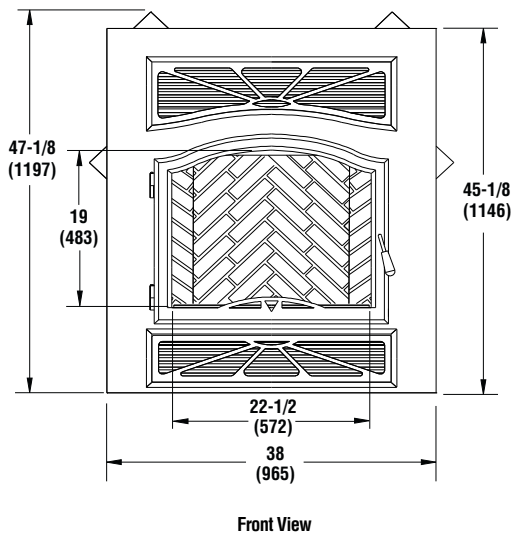
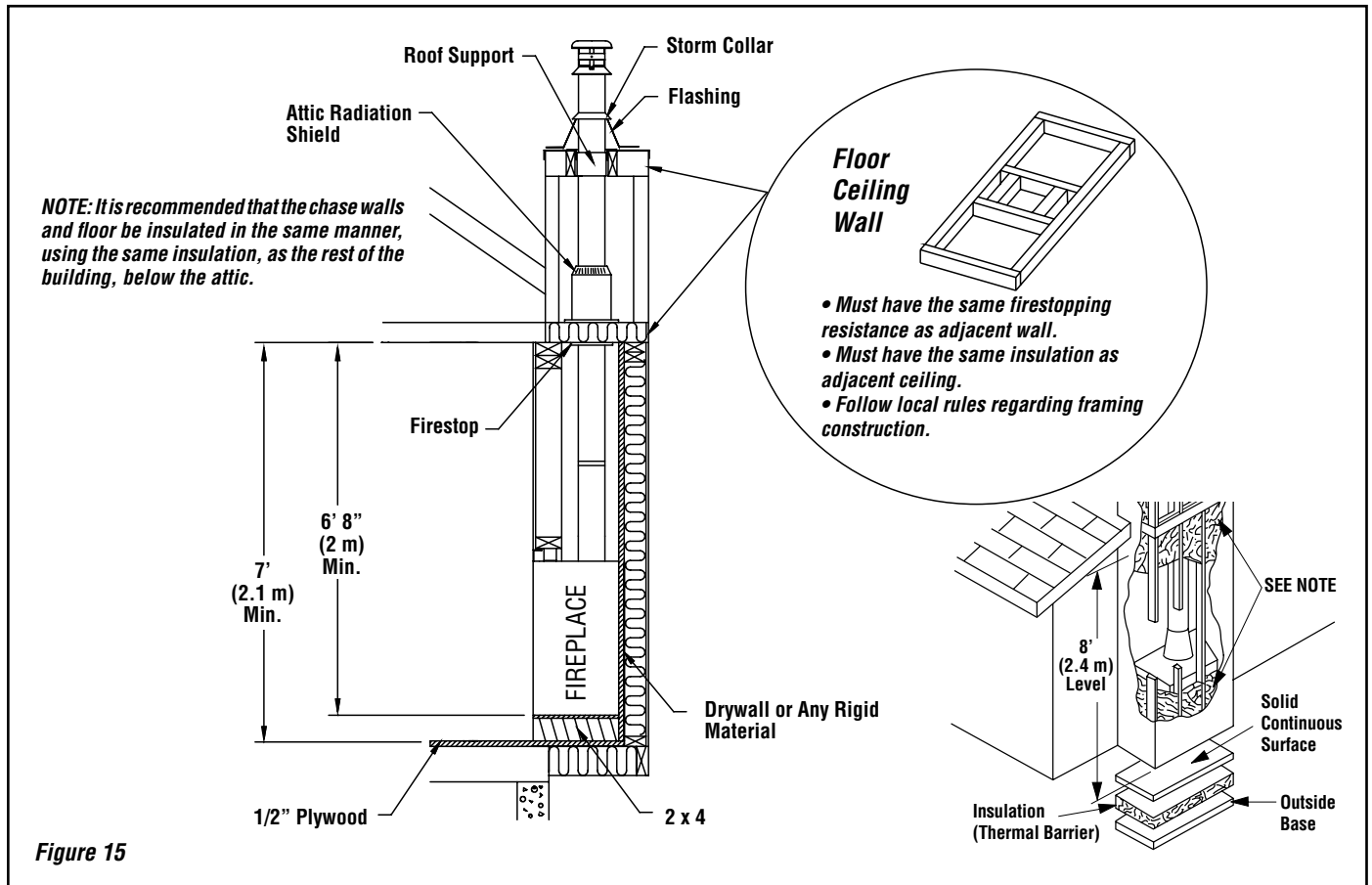

Figure 14 - Framing Dimensions

Insulated Chase Construction



Chase Enclosure

A chase is a vertical box-like structure constructed to surround the fireplace and chimney. Refer to **Figure 15** for a typical chase configuration. As with all chimney installations, avoid overhead obstructions such as trees, power lines, etc. A chase should be constructed and insulated just like any outside wall. In a cold climate, we recommend the base of the chase should also be insulated between the solid continuous floor beneath the fireplace and the chase bottom. Chase insulation in a cold climate installation is not required for safety.

NOTE: 2" clearance to combustibles around chimney components required.

NOTE: Blown or fill type insulation materials must not be in contact with the fireplace or in the enclosure frame as described in "Enclosure" section.

NOTE: Local codes may not require firestopping at the ceiling levels for outside chase installations. However, it is recommended for safety and the reduction of heat loss.

⚠ WARNING

If insulation is used, the fireplace must not be placed directly against it. Insulation or vapor barriers, if used, must first be covered with drywall panels, plywood, particle board or other material to assure insulation and vapor barriers remain in place.

⚠ WARNING

Do not pack or fill required air spaces with insulation or other material. No material is allowed in these areas.

Nailing Flanges

Four nailing flanges are provided to secure the fireplace to the floor (see **Figure 16**). Bend the nailing flanges down so that each flange is flush with the floor, then using nails or screws, secure the fireplace to the floor (2 places each side). The heads of the screws or nails must be large enough to completely cover the holes in the nailing flanges.

There are also nailing flanges on both vertical facing sides of fireplace (not shown).

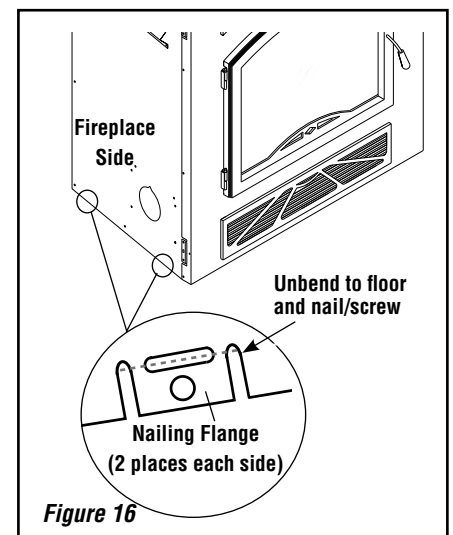

Facing

1. Combustible wall (such as drywall panels) must be installed flush with the fireplace. It may not project in front of and on the fireplace (i.e. the steel facade of the fireplace (see **Figure 17**).
2. Decorative frame made of combustible material cannot project in front of and on the fireplace steel front, in the space delimited by the width of the unit (38") and a height of 54" from the base of the appliance (see **Figure 19**).
3. Non-combustible materials such as brick, stone or ceramic tile may project in front of and onto the fireplace facing (see **Figure 18**).

Mantel

The mantel must be installed at least 54" (1372 mm) above the base of the fireplace (see **Figure 17**).

***NOTE:** Mantel can be reduced to 48" (1219 mm) if the Clean Face Panel option is installed with the heatflo kit.

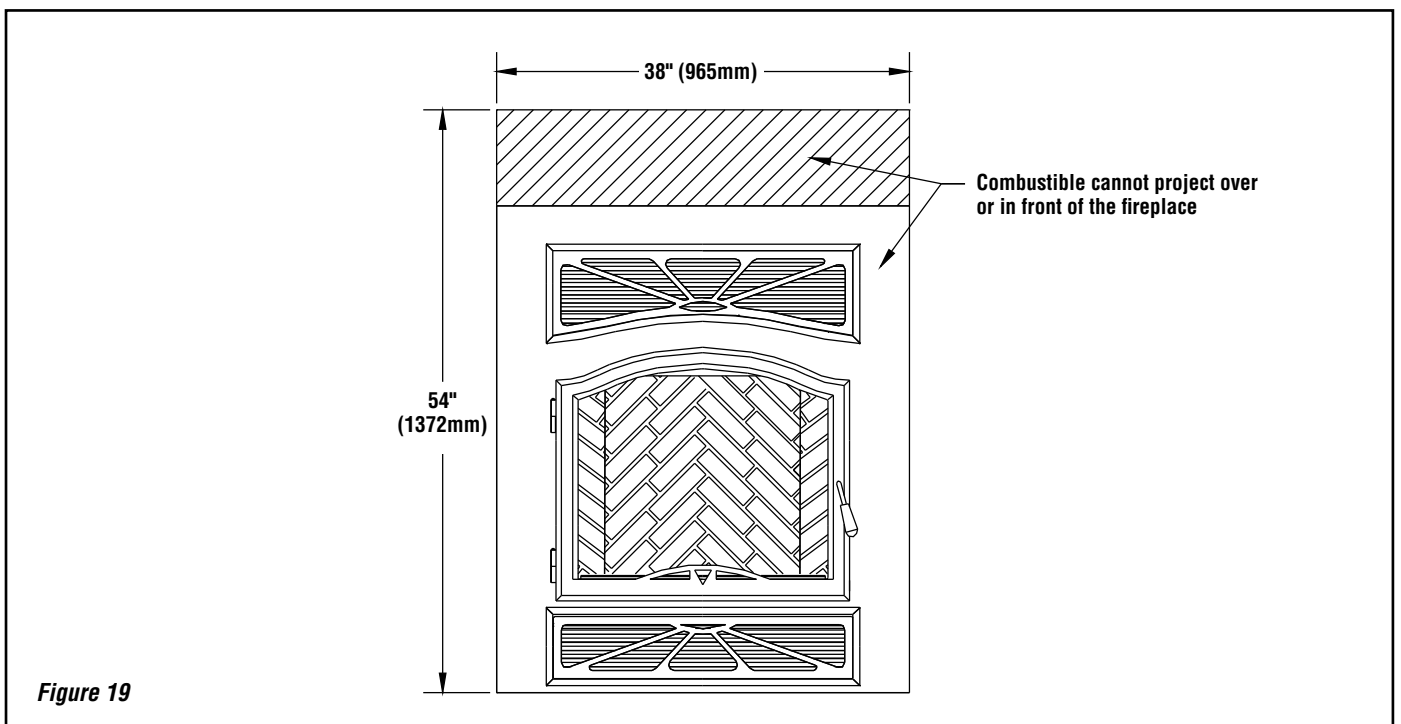
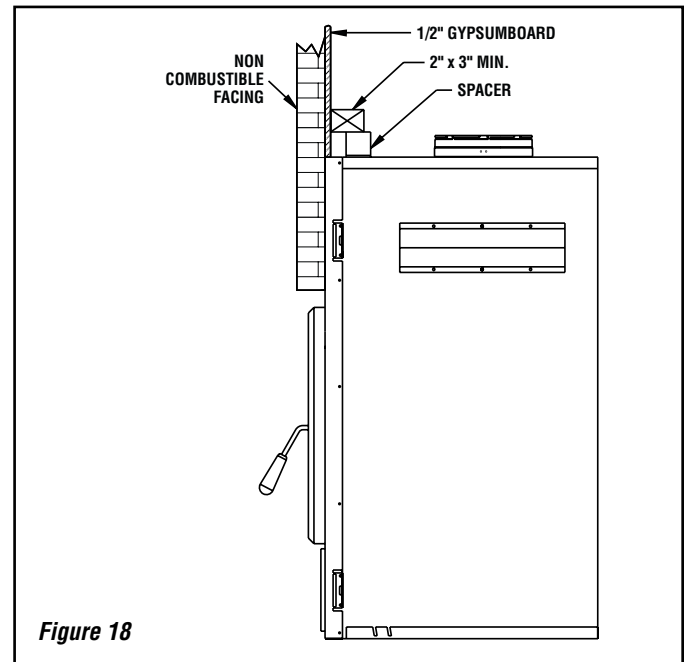
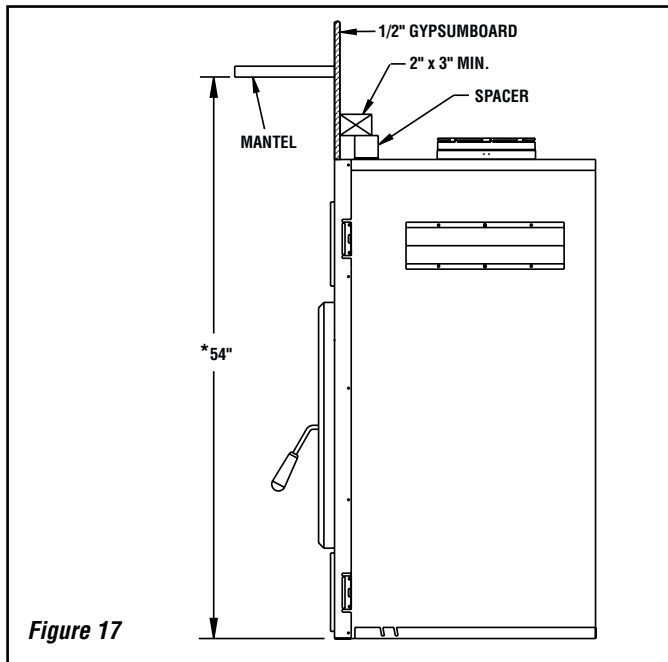

OUTSIDE AIR KIT

During operation, the fireplace requires fresh air for combustion and draws air from outside the house. It may starve other fuel burning appliances such as gas or oil furnaces. As well, exhaust fans may compete for air, causing negative pressure in the house, resulting in smoke entering the house from the fireplace. This situation is aggravated in modern airtight houses. To overcome this potential problem, we **require the installation of an outside air assembly**.

The outside air assembly must be installed according to the following requirements :

1. Duct length should be kept to a minimum. The maximum length of a 4" I.D. (100mm) insulated flexible duct is 20 feet (6.1 m). The duct can be extended to a maximum of 40 feet (12 m) using a 6" I.D. (150mm) insulated flexible duct.
2. The air intake register must not be installed more than 7 feet (2135 mm) above the base of the fireplace.
3. The fresh air must come from outside the house. The air intake must not draw air from the attic, from the basement or garage.
4. The air intake register should be installed where it is not likely to be blocked by snow or exposed to extreme wind and well away from automobile exhaust fumes, gas meters and other vents.
5. The duct and register may be installed above or below floor level.

Outside Air Installation

Make a 4-1/4" (110 mm) hole in the outside wall of the house at the chosen location. From outside, place the outside air register in the hole (open side down) and fasten the register to the wall, with screws as shown (see **Figure 20**). Slip the pipe into the insulated sleeve. Place the insulated pipe over the register tube and over the fireplace's outside air connector (see **Figure 21**). At each end, carefully pull back the insulation and plastic cover exposing the flexible pipe.

Using the aluminium tape provided, wrap the tape around the joint between the flexible pipe and the air inlets. Carefully push the insulation and plastic cover back over the pipe. Using aluminium tape, fasten the plastic cover in place.

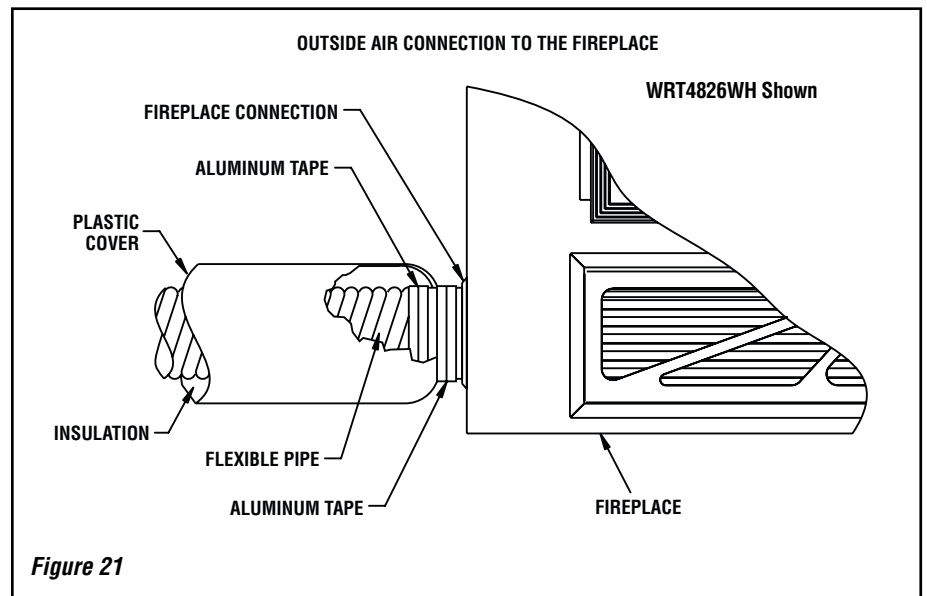
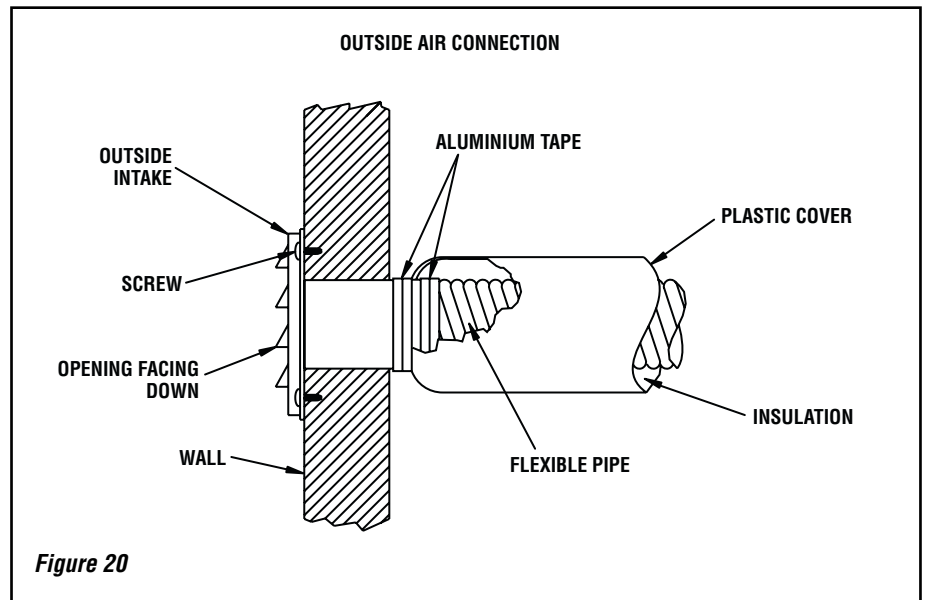

DRAFT REQUIREMENTS

Draft is the force which moves air from the appliance up through the chimney. The amount of draft in your chimney depends on the length of the chimney, local geography, nearby obstructions and other factors. Too much draft may cause excessive temperatures in the appliance and may damage the catalytic combustor. Inadequate draft may cause backpuffing into the room and 'plugging' of the chimney or the catalyst."

Inadequate draft will cause the appliance to leak smoke into the room through appliance and chimney connector joints.

An uncontrollable burn or excessive temperature indicates excessive draft.

HEATFLOW CONVECTION KIT INSTALLATION

The wood burning fireplace is approved for use with a Heatflow Convection Kit (hot air ducting system).

KIT CONTENTS (See Figure 22):

The Ducted Flex Kit must use both hot air outlets and includes:

- 2 ea. Wall Thimble Assembly (item #1)
- 2 ea. Duct Adaptor (item #2)
- 2 ea. Duct Ring (item #3)
- 8 ea. #6-18 X 2 Drywall Screw (item #4)
- 22 ea. #10-16 X 3/4" Hex-Unslotted Drive Zinc Finish Self-Drilling Screw (item #5)
- 2 ea. 2 Ply 8" Dia. X 10' Aluminum Flex with R4 Insulated Sleeve (item #6)
- 2 ea. Grill, White (item #7)
- 4 ea. #6-18 X 1-1/2 White Oval Head Zinc Plated Phillips Screws (item #8)
- 1 ea. Instruction Sheet

EPA Fireplace - HeatFlo Convection Kit

Cat. No.	Model	Description
F3790	EPA-HEATFLO-KIT	EPA Heatflo Conv. Kit

Table 3

TOOLS NEEDED:

5/16" hex driver and no. 2 Phillips screwdriver

GENERAL INFORMATION

If you encounter any problems, need clarification of these instructions or are not qualified to properly install this kit, contact you local distributor or dealer.

Read this instruction sheet in its entirety before beginning the installation.

ALL WARNINGS AND PRECAUTIONS IN THE INSTALLATION AND OPERATION MANUAL PROVIDED WITH THE APPLIANCE APPLY TO THESE INSTRUCTIONS.

TURN OFF THE APPLIANCE AND ALLOW IT TO COMPLETELY COOL BEFORE PROCEEDING.

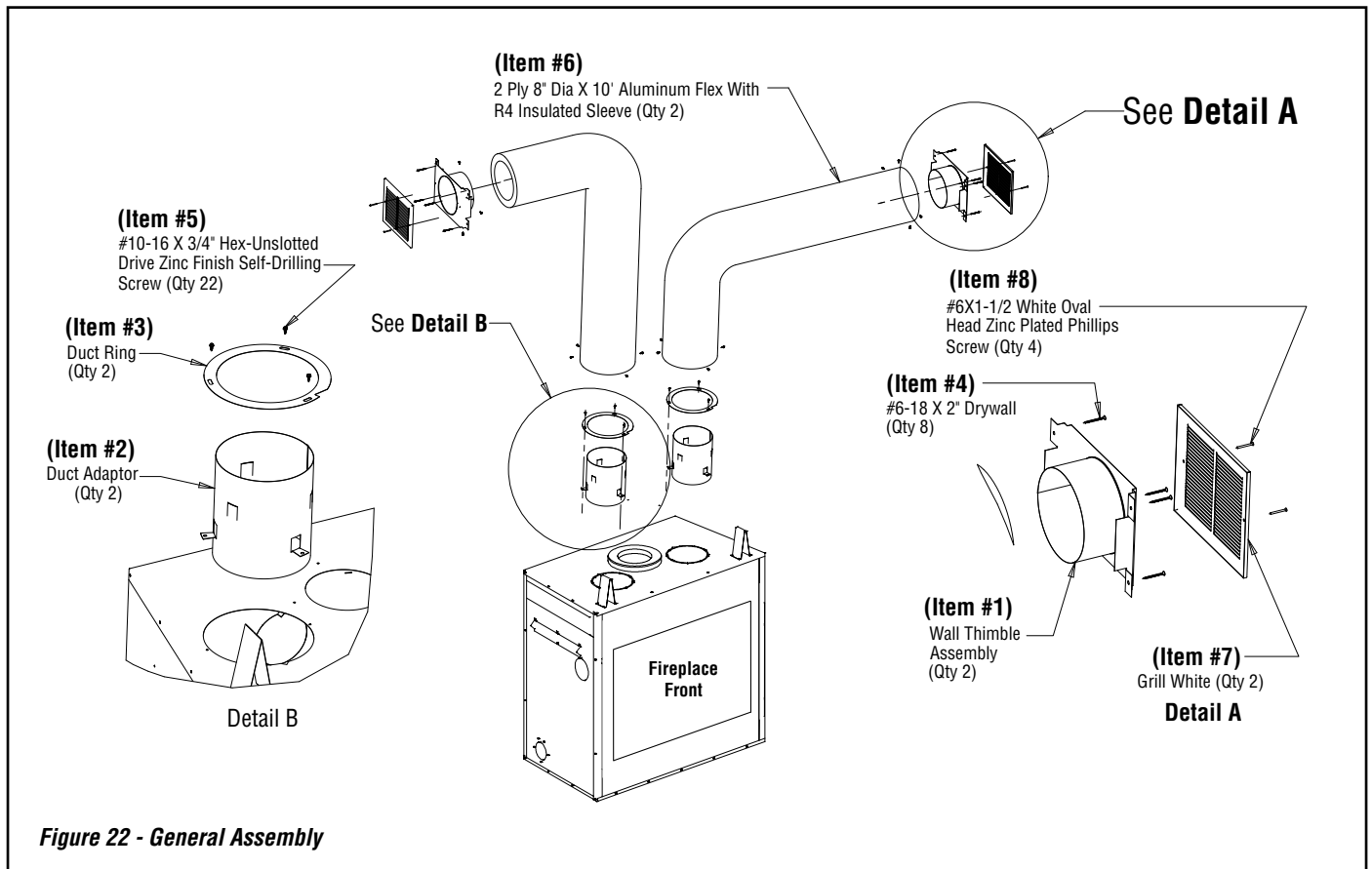

HEATFLOW CONVECTION KIT INSTALLATION (continued)

INSTALLATION INSTRUCTIONS:

For approved installations, the ducted flex kit must meet the following requirements:

Minimum height: 68" (1.7m)

The height of the louver must be measured from the base of the fireplace to the center point of the louver.

Minimum Ceiling and Side Wall Clearances: 11" (280mm)

Louver ceiling and side wall clearance must be measured from the bottom of the ceiling or from the side wall to middle point of the louver.

Maximum Length: 10' [3.1m] (See Figure 23)

It is recommended that the ducted flex kit duct system be installed in the following order:

1. Plan and frame fireplace and outlet locations prior to ducted flex kit installation.
2. Remove the two 8" diameter cutouts on top of the fireplace. Then, cut the insulation in order to obtain two 8" diameter openings and remove the insulation.
3. On the duct adaptor, bend the appropriate tabs down so that the bottom of the adaptor is just below the bottom of the insulation.
4. Align the collar slots with the holes in the adaptor; fasten the collar and the adaptor to the top of the fireplace using 3 of the sheet metal screws provided. The collar will fit loosely around the openings (see Figure 24).

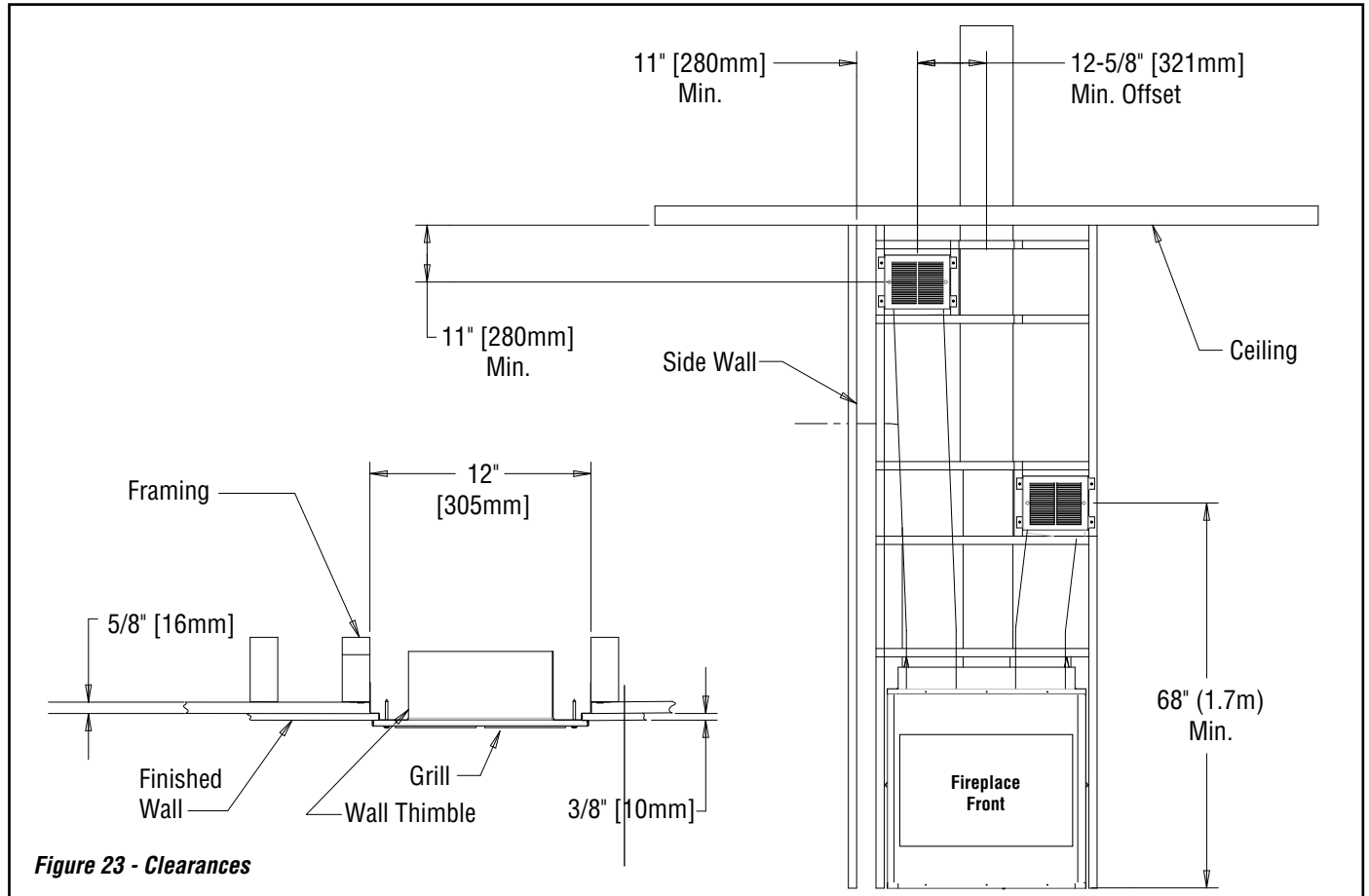

Figure 23 - Clearances

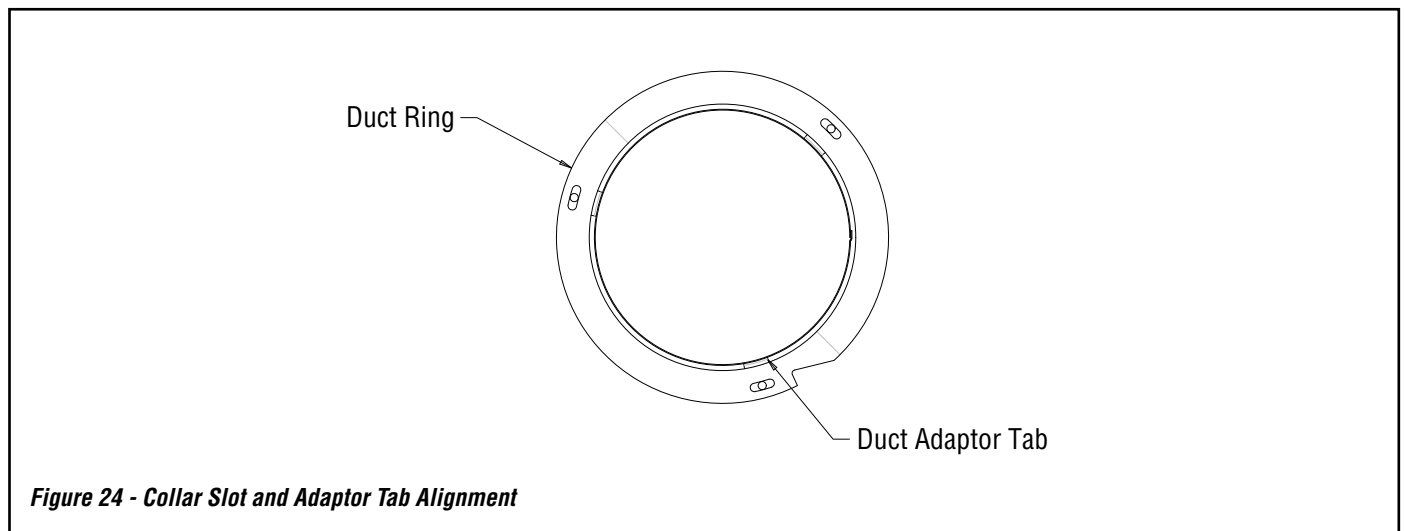
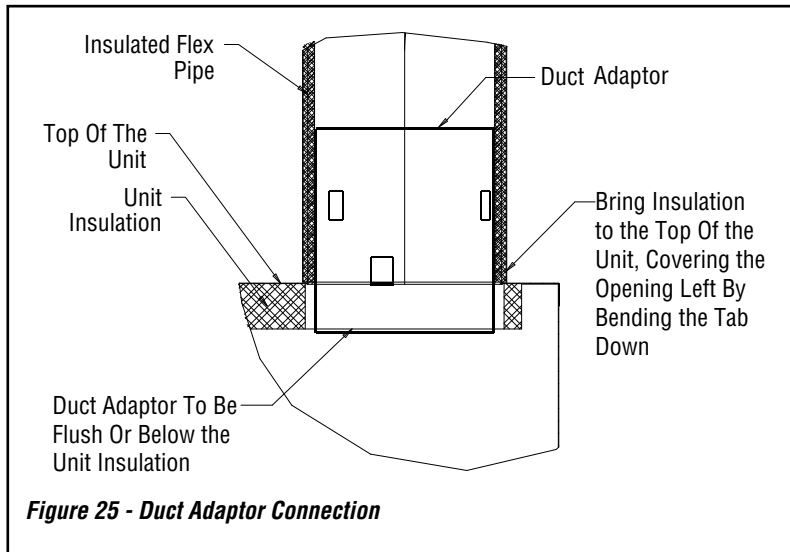

Figure 24 - Collar Slot and Adaptor Tab Alignment

HEATFLOW CONVECTION KIT INSTALLATION (continued)

5. Fit the wall thimble onto the flex-pipe, prior to the wall thimble installation, and fasten together using 4 sheet metal screws. Measure from top of fireplace to planned outlet location and trim the flex-pipe if necessary.
6. Install the wall thimble to the outlet framing using 4 of the supplied wood screws and run the flex pipe to fireplace.
7. Attach the bottom of the flex-pipe to the duct adaptor on the unit and secure using 4 of the supplied sheet metal screws. Bring the outside insulation and sleeve down to the top of the unit, ensuring that the openings in the duct adaptor, (left by bending the adaptor tabs down) are fully covered (see **Figure 25**).



INSTALLATION NOTES:

- When framing for the outlet grill: The minimum height from the bottom of the unit to the center of the outlet is 68" (1.7m) with the minimum distance from the center of outlet to the ceiling and for the center of the outlet to a side wall of 11" (279mm).
- Do not connect the hot air ducts to a central heating system.
- Use only IHP grills and components as described in this manual.
- Ensure that the flex insulation and sheathing do not touch the flue pipe.
- Never allow the pipe to pitch downwards. Never route the piping downwards.
- The hot air outlet grills must be installed with the louvers pointing downwards.
- The hot air outlets can be installed in the same room as the fireplace, or one or both of the outlets can be installed in adjacent or upper rooms. Installing the ducts at different elevations will tend to exhaust more heat out of the higher outlet
- When traversing a combustible wall or floor, a firestop (not provided) must be installed at the wall or floor penetration. Maintaining a minimum 1" (25mm) clearance between the ducts and any combustible material, the hole size must be 13" X 13" (330mm X 330mm) (see **Figure 26**).
- Install to local codes and regulations.

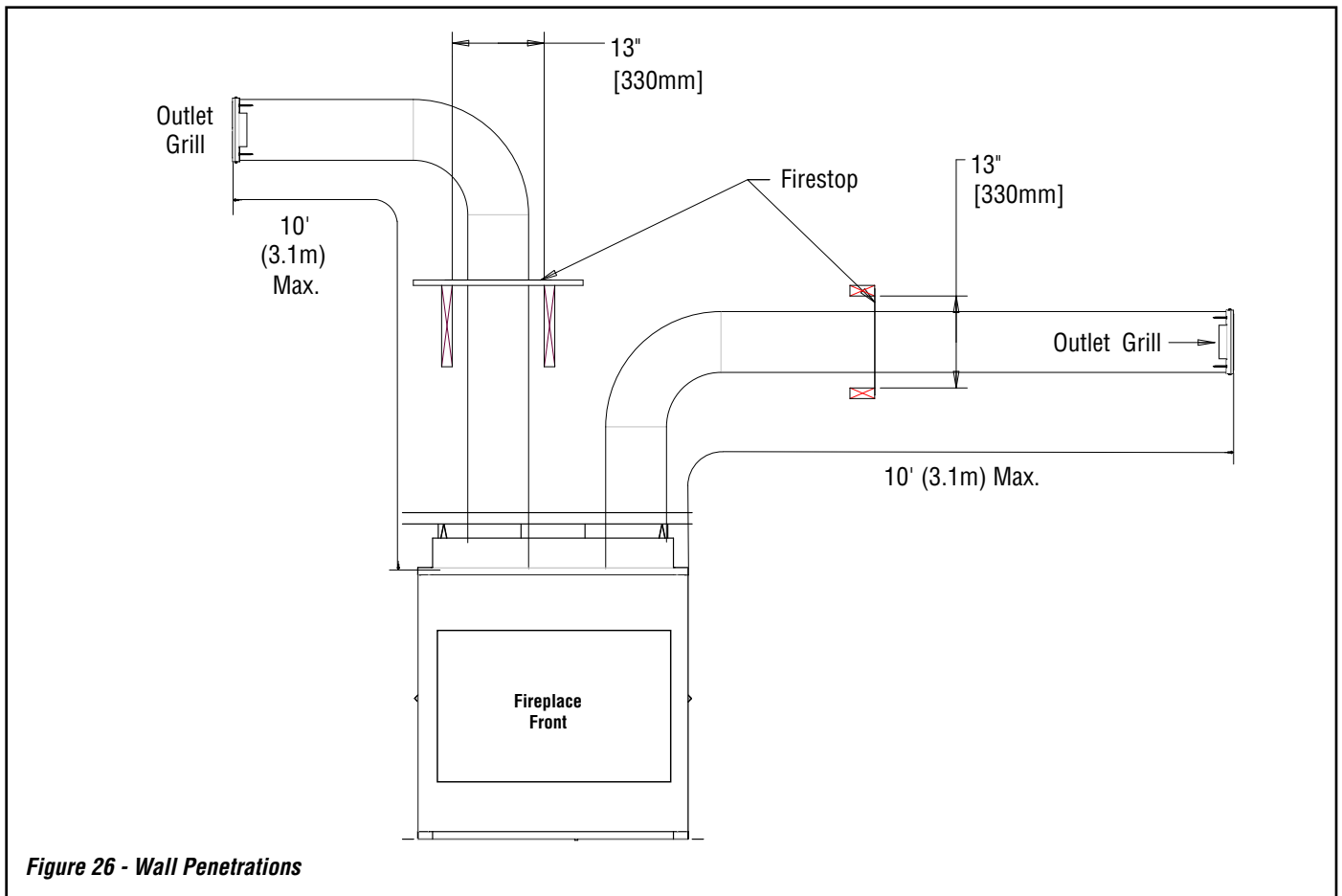

NOTE: DIAGRAMS & ILLUSTRATIONS ARE NOT TO SCALE.

THE CHIMNEY SYSTEM

Chimney Installation Notes

1. This appliance may be installed only with IHP 7" Snap-Pak chimney in the United States or Security Chimney models ASHT & S2100 or DuraVent model DuraTech Canada (DTC) in Canada. The 7" Security systems are approved in Canada with the use of an adaptor. See **Pages 2 and 29** for approved venting components.
2. If possible, install an interior chimney as it will provide better performance. In areas with continuous temperatures below 0°F (-18°C), the use of an exterior chimney increases the likelihood of operating problems such as low draft, high rate of creosoting, and poor start-up characteristics. Exterior chimneys are also prone to down-drafting and flow reversal. Installations, which are located on lower floors in the house, such as in a basement, in combination with outside chimney, are especially prone to flow reversal.
3. A chimney venting a fireplace shall not vent any other appliance.
4. The minimum chimney height is 12 feet (3.7 m) excluding the fireplace. To compensate for altitude, add 18" (450 mm) to the chimney for every 2,000 feet (600 m) above sea level.
5. **All chimney installations must include at least one support.** Reducing the amount of chimney weight on the fireplace will help avoid the noise created when the fireplace expands. This can be achieved by having the chimney supported by the supports. The maximum chimney length that can be supported by the fireplace is nine (9) feet (2.75 m).
6. The chimney must extend at least 3 feet (915 mm) above its point of contact with the roof and at least 2 feet (610 mm) higher than any wall, roof or building within 10 feet (3m) of it (see **Figure 21**).
7. If the chimney extends higher than 5 feet (1500 mm) above its point of contact with the roof, it must be secured using a brace and guy wires.
8. A rain cap must be installed on top of the chimney. Failure to install a rain cap may cause corrosion problems.
9. Cut and frame square holes in all floors, ceilings, and roof that the chimney will go through to provide a 2" (50 mm) clearance between the chimney and any combustible materials. Do not fill this 2" space with insulation or any other combustible material.
10. Portions of the chimney which may extend through accessible spaces must be enclosed to avoid contact with combustible materials or damage to the chimney.
11. When offsets are used, the pipe may not penetrate a ceiling or floor unless it is running vertical (no 30° offsets).

NOTE: 2" clearance to combustibles around chimney components required.

NOTE: Blown or fill type insulation materials must not be in contact with the fireplace or in the enclosure frame as described in "Enclosure" section.

NOTE: Local codes may not require firestopping at the ceiling levels for outside chase installations. However, it is recommended for safety and the reduction of heat loss.

UNITED STATES ONLY CHIMNEY INSTALLATION INSTRUCTIONS USING IHP SNAP PAK (SP)

UNITED STATES APPROVED VENTING SYSTEMS:

- 7" diameter chimney:** Model IHP Snap-Pak, including:
- Chimney lengths
 - Elbows (*where necessary*)
 - Associated components as per these installation instructions

INSTALLATION THROUGH FLAT CEILING(S)

- Using framing lumber equal to ceiling joist size, frame ceiling opening as shown in **Figure 27** and **Table 4**.

Chimney Flue Diameter	
	7"
A	13-7/16"
B	13-7/16"

Table 4

If the area above the ceiling is an attic, go to step 5.

- Install SNAP-PAK chimney sections starting at the top of the appliance. Leave the first section loose until the installation is complete to allow the chimney to be rotated, easing the installation of any offsets if they are used. Secure subsequent sections by pushing together until stop-locked (see **Figure 28**).
- If IHP Elbows are to be used because the chimney is to be offset, refer to "Installation of Elbows" section. Directly above the Center of the flue in the ceiling support, mark the ceiling. A plumb bob is normally used to find the center. Cut an opening in the ceiling using **Figure 28** and **Table 4**.
- At each ceiling penetration, a firestop (SPFS) is required. Insert the SPFS into the joist area prepared in **Figure 27**.

NOTE: When the chimney extends between floors-which can be occupied-the chimney must be enclosed to prevent contact. As previously noted, 2" minimum clearance to combustibles is to be maintained at all times.

- The first chimney section through the joist area into attic is to be approximately two (2) feet. If the pipe sections in the attic are not enclosed, an insulation shield (SPIS) must be installed. Lower the insulation shield (SPIS) over the SP pipe until the SPIS flange is resting on the joist. Secure the SPIS in place by nailing the flange to the joist. See **Figure 29**. If the section within the attic area is to be chase enclosed, the SPIS is not required.

WARNING: Do not place any type of insulation in the required clearance spaces surrounding the chimney.

- Continue the chimney to the roof. See "Flashing Installation" and "Termination" sections.

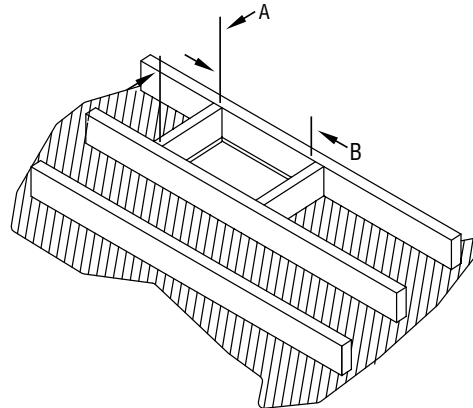

Framing lumber of equal size to the joist should be used.

Figure 27

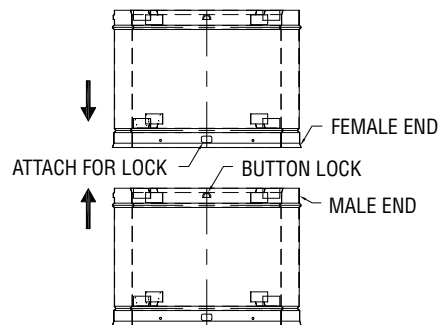

Figure 28

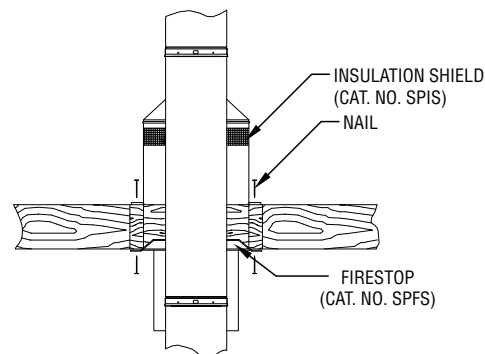

Figure 29

INSTALLATION THROUGH A SIDE WALL

1. It is recommended that exterior mounted chimneys be enclosed below the roof line in geographical areas experiencing sustained low ambient temperatures to help reduce or limit condensation, creosote buildup and poor draft.
2. Locate the area where the chimney section is to penetrate the vertical wall studs. Cut and frame an opening so that the flue is centered between the vertical wall studs. Frame opening per **Figure 30** and **Table 5**.

Chimney Flue Diameter	
	7"
A	13-7/16"
B	14"

Table 5

3. A 2-piece wall firestop (SPWF) must be installed in the framed opening from outside. The stainless portion is first installed from the outside of the opening. Push the remaining half through the opening from the inside until the plate is flush with stud. Use four (4) # 10 x 2-1/2" wood screws to attach opening (see **Figure 31**). Seal the outside plate with RTV sealant or similar.

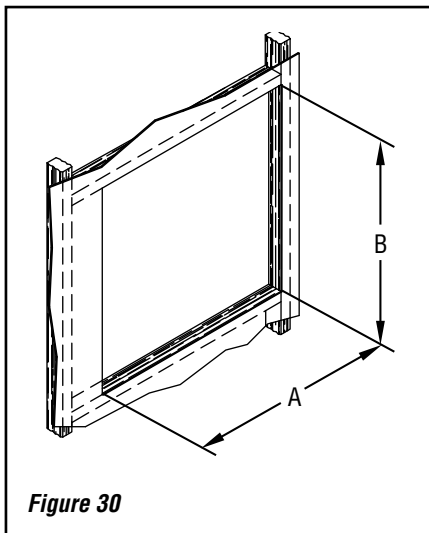

Figure 30

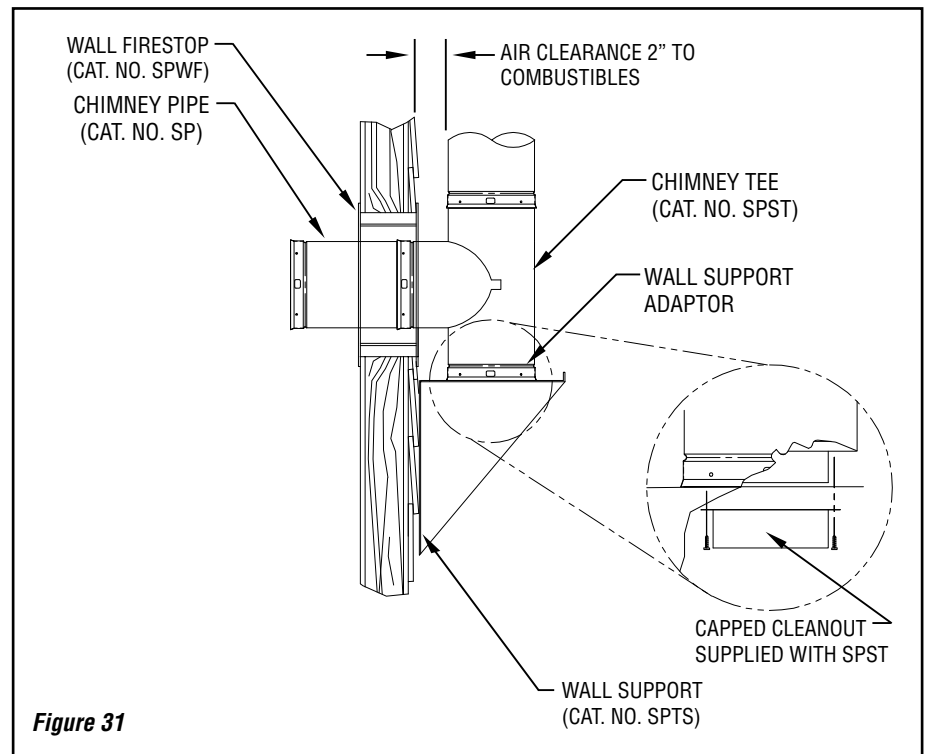

Figure 31

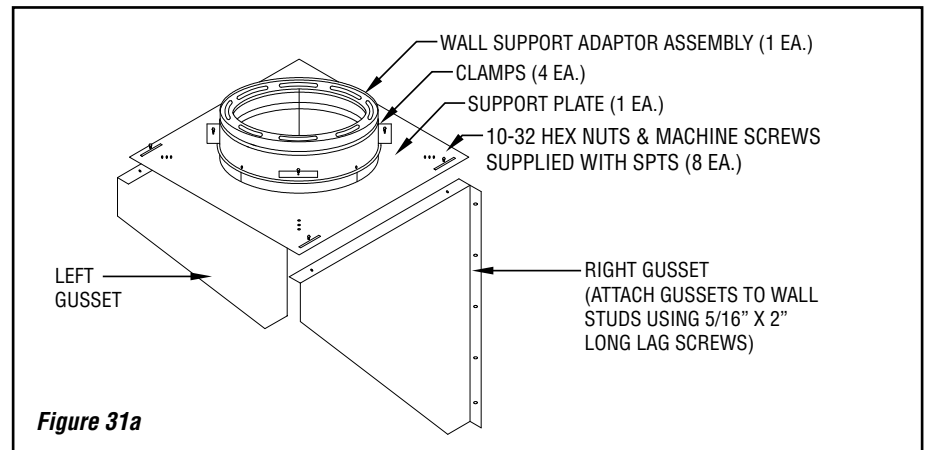

Figure 31a

4. Remove the wall support adaptor pieces from the SPTS box and attach the adaptor to the bottom of the tee by inserting it into the bottom of the tee and push to lock.
5. Push the side portion of the tee into the opening in the wall firestop.
6. Assemble the right and left gussets to the support plate using the hardware provided.
7. Attach wall support plate to wall support adaptor using 4 clamps provided. Do not tighten. (See **Figure 31a**).
8. Align the wall support with the wall and secure it to the wall studs using 5/16" x 2" lag screws (not provided). **DO NOT SECURE TO SIDING**. For masonry walls, use 5/16" x 2" masonry lag bolts.
9. Install the tee cap to the bottom of the wall support adaptor with a minimum of two (2) #10 x 1/2" sheet metal screws.
10. Position the tee and the adaptor on wall support to maintain 2" clearance to combustibles. AT THIS POINT TIGHTEN CLAMPS.
11. Slide IHP chimney pipe into top of tee. Align male and female ends. Push down on pipe sections until locked. As sections are added, it will be necessary to secure them to the outside wall with bands (SPWB) at eight foot intervals and 2" from combustibles. Wall Bands (SPWB) are secured to the chimney by placing band around the chimney and tightening clamping bolt. The assembly is anchored to the wall studs (not the siding) with 5/8" x 2" lag bolts. To complete the chimney installation, see "Flashing Installation" and "Termination" sections.

NOTE: DIAGRAMS & ILLUSTRATIONS ARE NOT TO SCALE.

ELBOW INSTALLATION

1. IHP provides a 15° (SPSE15) and 30° (SPSE30) Elbow to allow chimneys to avoid framing members or roof peaks. A maximum of 30° from the vertical is allowed, and a total of four elbows (two pair) for each chimney installation. Maintain 2" clearance to combustibles.
2. Attach the elbow(s) to the chimney pipe or other support part and push to lock. Using the offset chart, add chimney sections between the elbows. A support band (SPSB) is required at the upper elbow of the pair to support the load, as shown in **Figure 32**. Attach the upper elbow to bring the chimney back to vertical.

Offset combinations: see **Table 6** and illustration, **Figure 33**.

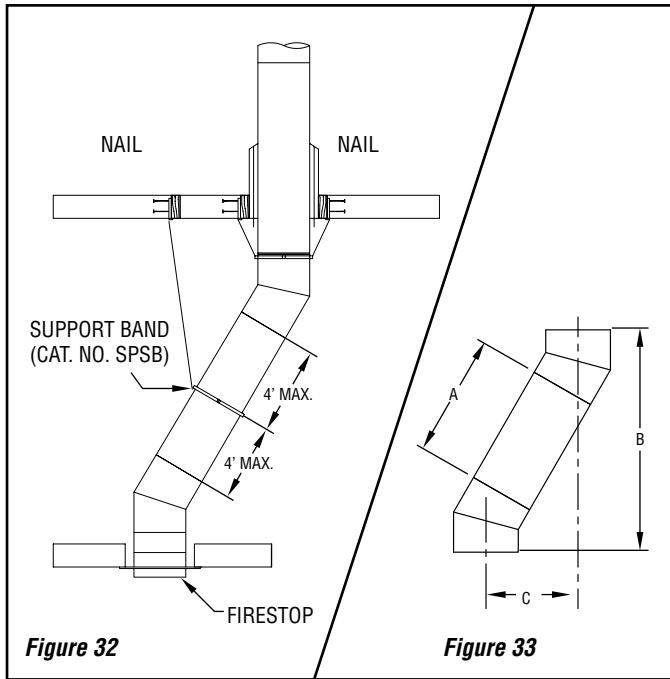

FLASHING INSTALLATION

1. Continue the SP chimney to the roof. Cut the roof opening, centered over the chimney. A 2 inch-airspace around the chimney is required as it penetrates the roof. The size of hole in the roof will vary depending on the roof pitch.
2. Install the next SP chimney section through the roof. See **Figure 34**.

NOTE: If your roof is already shingled, be sure to slide the upper edge under the shingles to prevent leakage.

3. Install a bead of caulk around the pipe at the top edge of the flashing. Wrap the storm collar around the pipe and imbed the edge in the caulk to prevent leakage around the pipe.
4. Continue to install pipe sections until the proper termination height is reached. See termination section.

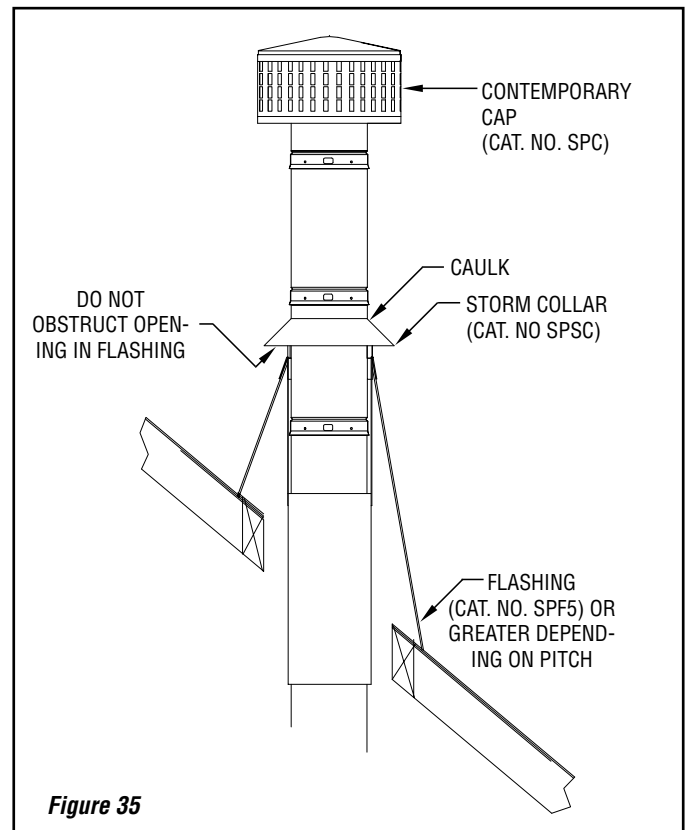
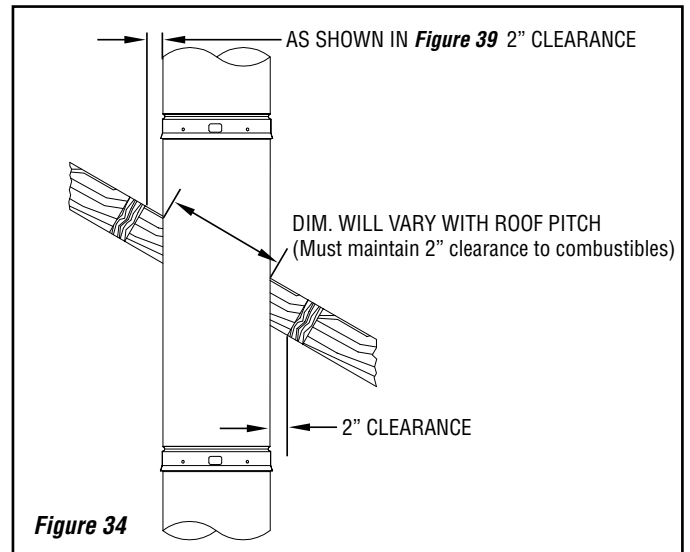

7" DIAMETER CENTER LINE OFFSET TABLE					
A		15° Angle		30° Angle	
Length	No. Pcs.	B	C	B	C
0	0	18-7/16"	2-1/4"	20-3/16"	5"
6"	1	22-13/16"	3-3/8"	24-1/16"	7-1/4"
12"	1	28-5/8"	4-15/16"	29-1/4"	10-1/4"
18"	1	34-3/8"	6-1/2"	34-7/16"	13-1/4"
24"	1	40-3/16"	8-1/16"	39-5/8"	16-1/4"
30"	2	44-1/2"	9-1/4"	43-1/2"	18-1/2"
36"	1	51-3/4"	11-3/16"	50-1/16"	22-1/4"
42"	2	56-1/8"	12-3/8"	53-15/16"	24-1/2"
48"	1	63-3/8"	14-1/4"	60-7/16"	28-1/4"
54"	2	67-3/4"	15-7/16"	64-3/8"	30-1/2"
60"	2	73-1/2"	17"	69-1/2"	33-1/2"
66"	2	79-11/16"	18-1/2"	74-3/4"	36-1/2"
72"	2	85-1/2"	20-1/16"	79-15/16"	39-1/2"
78"	3	89-7/16"	21-1/4"	83-13/16"	41-3/4"
84"	2	96-11/16"	23-3/16"	90-5/16"	45-1/2"
90"	3	102-3/8"	24-3/8"	94-3/16"	47-1/2"
96"	2	108-1/4"	26-5/16"	100-11/16"	51-1/2"

Table 6

TERMINATION

Many building codes specify a minimum chimney heights above the roof top. These specifications are summarized in what is known as the "Ten Foot Rule". This rule states:

If the horizontal distance from the side of the chimney to the peak of the roof is 10 feet or less, the top of the chimney must be at least 2 feet above the peak of the roof, but never less than 3 feet in overall height above the highest point where it passes through the roof (**Figure 36**).

If the horizontal distance from the side of the chimney to the peak of the roof is more than 10 feet, a chimney height reference point is established on the surface of the roof a distance of 10 feet from the side of the chimney in a horizontal plane. The top of the chimney must be at least 2 feet above this reference point, but never less than 3 feet in height above the highest point where it passes through the roof (**Figure 37**).

These chimney heights are necessary in the interest of safety and do not ensure smoke free operation. Trees, buildings, adjoining roof lines, adverse wind conditions-etc., may create a need for a taller chimney, should smoking occur.

Additional support is required above the roof if the chimney height exceeds four (4) feet.

Select the proper support for your application-using either a roof brace (**Figure 38**), or a support band with guy wires (**Figure 39**)

SP ROOF BRACE INSTALLATION

1. Assemble the attachment support band (SPSB) around the chimney, and clamp it in place at the desired height using the nut and bolt provided.
2. Loosely attach the support legs to the bolts on the attachment band using hardware provided.
3. Position the support legs as shown in **Figure 38**. The length of the support legs can be adjusted by loosening the bolt on the leg clamp.
4. Secure legs to roof using screws provided. Seal screw holes to prevent roof leaks.
5. Tighten all hardware.

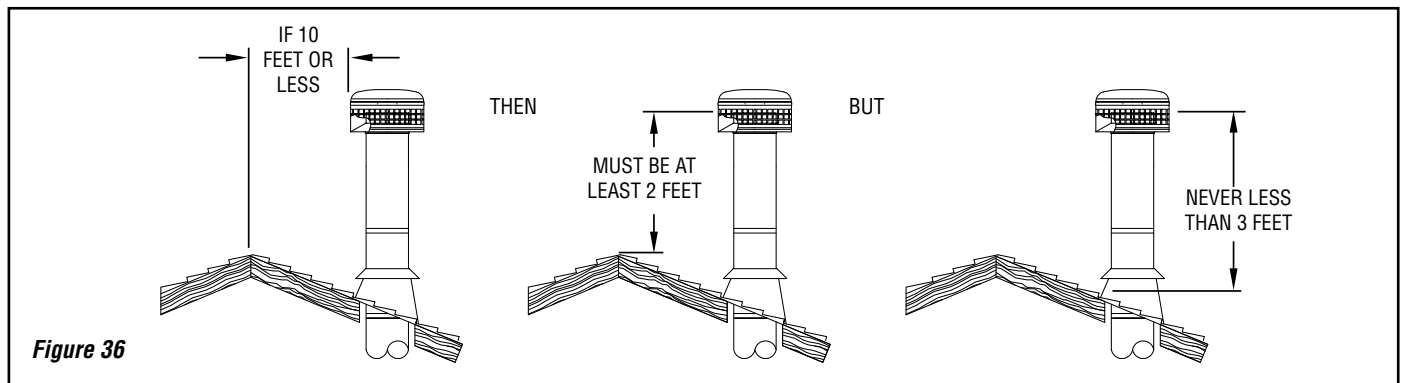

Figure 36

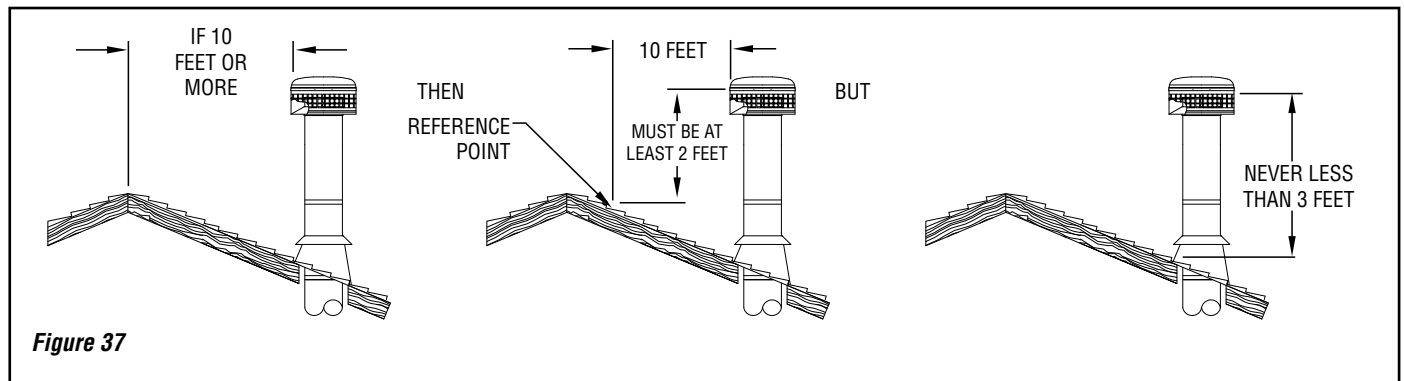

Figure 37

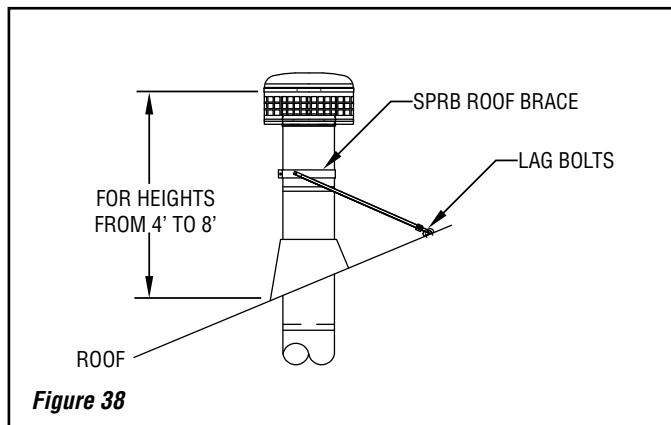

Figure 38

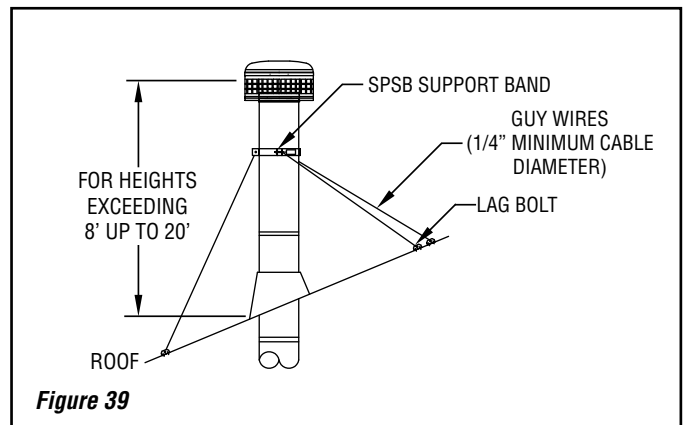

Figure 39

CANADA ONLY CHIMNEY INSTALLATION INSTRUCTIONS USING SECURITY CHIMNEYS ASHT

CANADA APPROVED VENTING SYSTEMS:

7" diameter chimney - Canada

Models ASHT® & S2100 manufacture by Security Chimneys® or DuraTech Canada (DTC) manufactured by DuraVent only, including:

- Chimney lengths
- Elbows (*where necessary*)
- Associated components as per these installation instructions and instructions provided by the venting Manufacturer

Reference the installation instructions provided by venting manufacturer.

CHIMNEY ADAPTOR-CANADA ONLY

The fireplace is normally supplied with a chimney adaptor suitable for use with IHP SnapPak venting. In Canada, the use of Security Chimneys ASHT adaptor is required (Security part number 7IHP1* or 7IHP2**).

* One inch wall

** Two inch wall

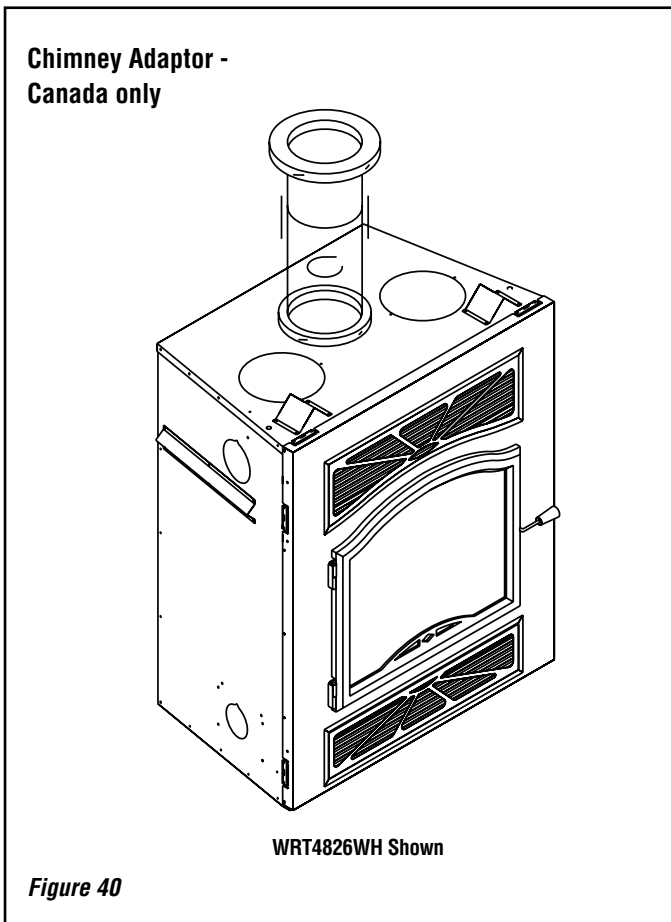

CHIMNEY CHASE AND MULTIPLE TERMINATIONS

For the purpose of this manual, a chimney chase is considered a part of the chimney system rather than part of a building. The termination must be placed a minimum of 18" (460 mm) above the chase.

For installations where more than one chimney is located in the same chase or within the same area, we suggest that their terminations be separated by at least 16" (410 mm) horizontally, and 18" (460 mm) vertically. This separation is to prevent smoke migrating from one chimney to another (see **Figure 41**).

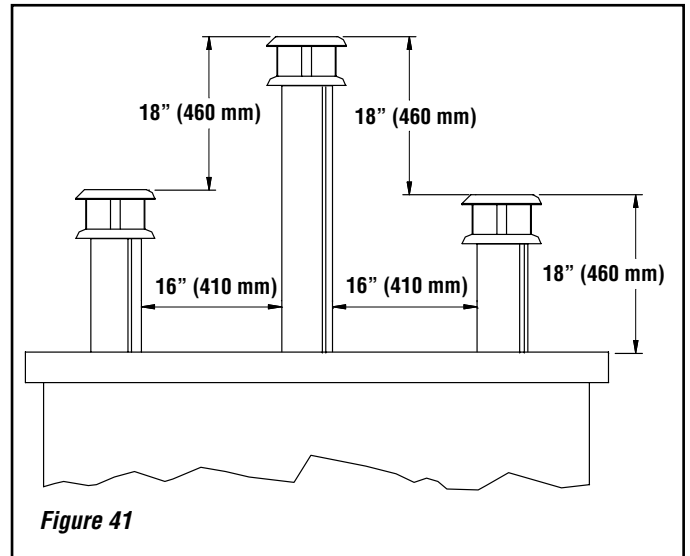

INSTALLATION INSTRUCTIONS FOR MASONRY APPLICATION

WARNING: Before starting the installation, the masonry chimney must be inspected by a qualified chimney sweep.

The following requirements must be respected:

1. The chimney must be absolutely clear of any soot residue or creosote. Check for cracks, loose or missing bricks that could inhibit correct installation of the liner.
2. The clearance to combustibles must be a minimum of 1" between the outside of the masonry and any wood framing or loose insulation.
3. The chimney must be built in accordance with the current building code.
4. No other appliance can be connected to the same chimney.
5. The clearances to combustibles for these fireplace connectors are 2" on the side and bottom and 16" at the top.
6. The connector parts are not necessary if the connection between the insulated length and the stainless steel liner is done within the masonry chimney.

Installation:

Rigid stainless liner or stainless flex must be used and listed to UL-1777 for US applications and ULC-S635 for existing masonry or ULC-S640M for new masonry applications in Canada. The steel rigid or flex liner must be rated at 2100°F (1100°C).

Follow these steps:

- 1- Position the fireplace in its location. Temporarily install the 30° insulated elbow on the top of the fireplace and, using a level, mark with an oval the location where the flue liner will enter the masonry chimney.

- 2- In the middle of the oval, drill a hole in the masonry chimney at 30°.
- 3- Increase the size of the hole until a 30° liner elbow can be easily slipped through.
- 4- Slide the liner down from the top of the masonry chimney until you reach the hole level.
- 5- Slip through the hole a 30° liner elbow and connect it to the liner.
- 6- Add a small liner section to the liner elbow which will allow the liner to extend at least 12" (measured at the top of the liner) from the masonry chimney.
- 7- Seal the opening around the liner with high temperature refractory cement.
- 8- The next steps must be done in the following order:

See typical installation illustrated below.

- A. Select the insulated pipe length that will fit between the 30° insulated elbow on top of the appliance and the exposed liner so that it will slide at least 2" over the liner section (You may need to cut the liner for a better fit).
- B. Take that section and attach the pipe to the insulated liner connector and slide it over the liner. Make sure you have enough opening to be able to install the elbow without difficulty.
- C. Install the 30° elbow on the fireplace.
- D. Slide the length section back down on the elbow and twist lock the two together.
- E. Pull the cover down over the length and install the insulation pad over the liner; be careful to cover the liner completely.
- F. Slide back the cover over the insulation and fix it in place using the 3 metal screws supplied.

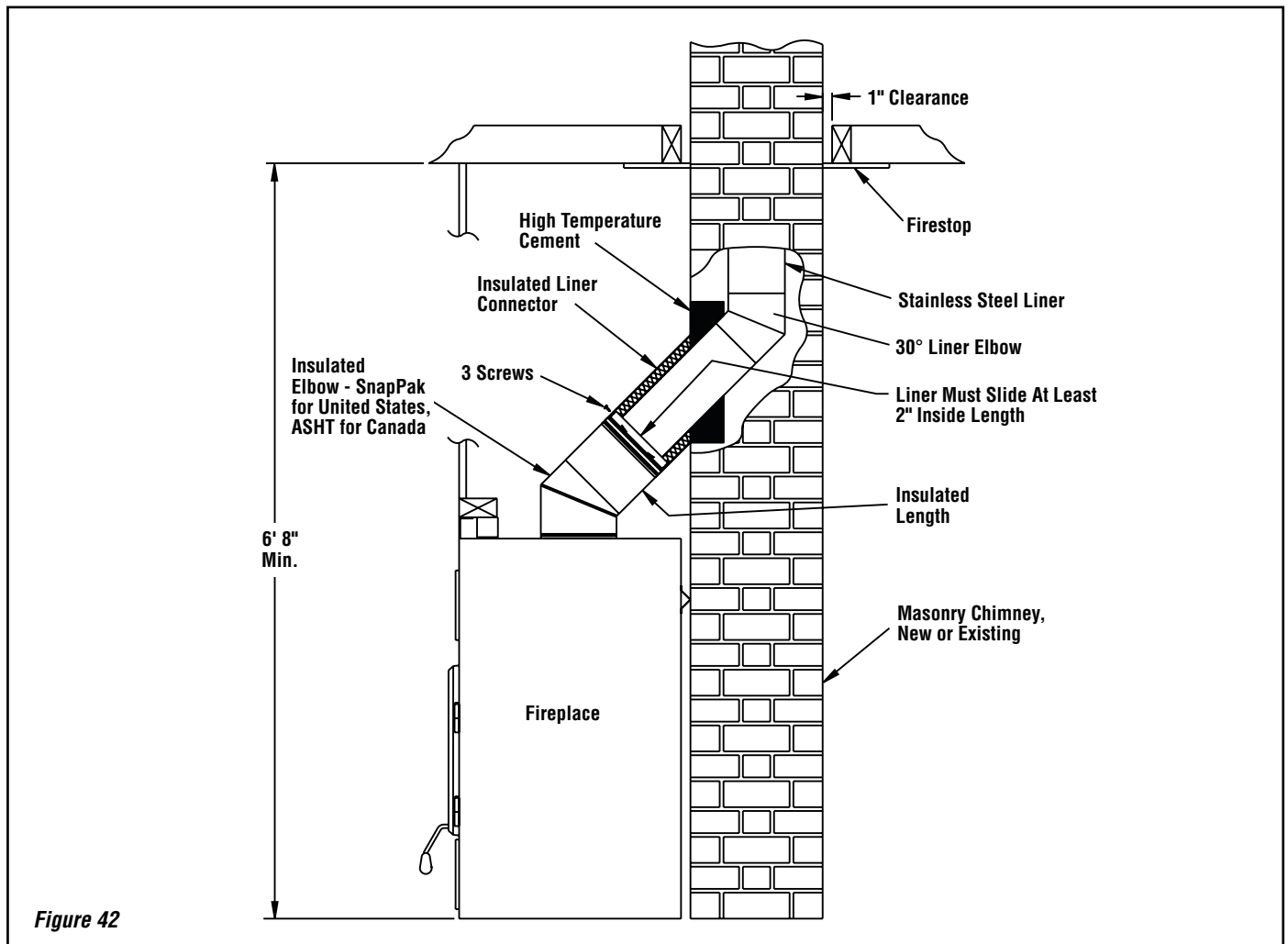
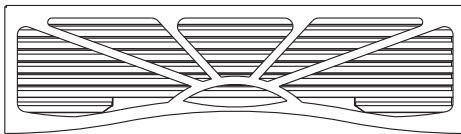

Figure 42

OPTIONAL INSTALLATION ACCESSORIES

Installation Accessories	
Description	Cat./ Part No.
Decorative Cast Iron Door (Required - Order Separately)	
Arch Shape Door, Black, BPVBK	F1854
Louver Kits	
Del Sol Louver Kit	DEL SOL
Diamante Louver Kit	DIAMANTE
Strada Louver Kit	STRADA

Louver Kits



Del Sol

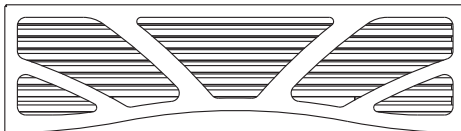

Diamante

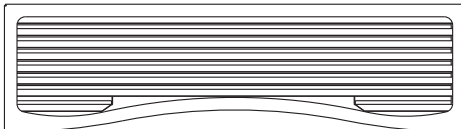

Strada

Misc. Fireplace Options	
Clean Face Panel Kit (Requires HeatFlo Kit)	BPCF
Blower	UZY5
Blower Motor Speed Control	VRUW
Outside Air Kit (Required - Included with Fireplace)	
Outside Air Coupler to Connect Outside Air UZI to Fireplace, UZIAD	UZIAD
Outside Air Ducting - Includes 4 in. Insulated Flex x 10 ft. long, UZI	UZI
Central Forced Air Kit Accessories ❶	
Central Forced Air Kit, Central forced air kit including: blower (BISZY), flex adaptor (BISAF), 2 clamps, variable speed control (VRUW), thermo-disk (VTU), fan to flexible pipe adapter (BISAVF), back draft damper (BISBD), aluminium tape, BISFWK-1	BISFWK-1
Flexible pipe 5" I.D. x 15 ft. Long, 5FLEX15	5FLEX15
Flexible pipe 5" I.D. x 30 ft. Long, 5FLEX25	5FLEX25
Heating and cooling thermostat, 24V, HCTW	HCTW
EPA Fireplace - HeatFlo Convection Kit	
EPA Heatflo Conv. Kit, EPA-HEATFLO-KIT	F3790

REPLACEMENT PARTS LIST

Replacement Parts	
Description	Cat. No.
Front Refractory	PR-SR2113
Back Refractory	PR-SR2056
Right Side Refractory	PR-SR2057D
Left Side Refractory	PR-SR2057G
Bottom Refractory	PR-SR2055
Catalytic Combustor	PR-SR2110
Catalytic Combustor Stainless Steel Casing	PR-SR2111
Catalyst Air Tube (front)	PR-SR2053
Cast-iron Log Supports (2)	PR-B2CH
Louver frame (top)	PR-SR2131
Louver frame (bottom)	PR-SR2130
Ash pan gasket	PR-B2GA1
Ash pan	PR-BISUZH
Fireplace top	PR-SR2436
Fireplace left side	PR-SR2435
Fireplace right side	PR-SR2434
Fireplace back	PR-SR2432
Door, Arched Black	F1854
Wooden Door Handle	PR-SR1787
Wooden Handle By-pass	PR-SR2072
Handle Rod and lock	PR-SR2118
Ceramic Glass Panel	PR-SR2107
Glass Gasket, 83"	PR-SR1823E
Door Gasket, 92"	PR-SR1823D
Hinge Kit	PR-SR2395P
Secondary Air Tube (rear)	PR-SR2051
Log Retainer Bar	PR-SR2323
Touch-up Paint, Aerosol, Black Metallic SBMB6309	H8159
Blower 250 CFM for central forced air kit, BISZY	BISZY
Blower variable speed control with decorative wall plate for (BISZY), VRUW	VRUW
Thermo-disk, on/off blower control (for BISZY), VTU	VTU
Blower to flexible pipe adaptor, BISAVF	BISAVF
Backdraft damper, BISBD	BISBD
Fireplace to Flex adaptor and 2 clamps, BISAF	BISAF
Thermopile, gauge and label replacement	J8004

SPECIFICATIONS

Cat. No.	Model	Description
F1795	WRT4826WH	WRT4826WH EPA Fireplace

Model	Emission Rate	Heat Output	EPA Estimated Efficiency
WRT4826WH	4.1 g/hr	10,900-35,600 btu/hr	72%

Product Reference Information	
Weight	385 lbs
Height	45"
Width	38"
Depth	24-1/2"
Chimney Weight ASHT+ (7" dia)	7.8 lb per linear foot
Chimney Weight ACBI (8" dia.)	3.75 lb per linear foot

CLEARANCE TO COMBUSTIBLES

The following clearances meet the minimum requirements for a safe installation;

Side wall: 24" (610 mm) measured from the doors edge

Ceiling: 6' 8" (2032 mm) measured from the base of the fireplace

Fireplace enclosure:

Bottom: 0"

Side: 0" to spacer

Back: 0" to spacer

Top: Do not fill the space above the fireplace with any material (7 feet measured from the base of the fireplace)

Chimney:

See **Pages 26-28** for approved chimney systems.

Mantel: 54" (1372 mm) measured from the base of the fireplace or 48" (1219) when installed with Clean Face Panel option (see **Page 24**) and Heatflo Kit.

Contact an IHP dealer to obtain any of these parts. Never use substitute materials not approved by IHP. Use of non-approved parts can result in poor performance and safety hazards.

SECURITY CHIMNEYS® AND DURAVENT® - PARTS AND COMPONENTS LISTS

The components listed below must be ordered from Security Chimneys® or DuraVent®. Contact your Security Chimneys or DuraVent Distributor or Dealer for ordering information.

Security Chimneys® 2125 Monterey, Laval, Quebec Canada, H7L 3T6 securitychimneys.com	450-973-9999 1-800-361-4909 (USA) 1-800-667-3387 (Canada)
-----------------------------------------------------------------------------------------------	-----------------------------------------------------------------

M&G DuraVent 877 Cotting Court, Vacaville, California, 95688 duravent.com	1-800-835-4429
------------------------------------------------------------------------------------	----------------

Secure Temp® ASHT 1" High Temp. Insulated Stainless Steel Chimney <i>7" I.D. and 11" O.D., Double-Wall Stainless Steel, Listed to CAN/UCL-S604, UL-103HT and CAN/ULC S629</i>	
Description	Cat./ Part No.
Lengths and Misc. Chimney Components	
Length 8", 7L8	7L8
Length 12", 7L12	7L12
Length 18", 7L18	7L18
Length 24", XL24	7L24
Length 36", 7L36	7L36
Length 48", 7L48	7L48
Adjustable Length 12", 7" Dia., 7LA	7LA
15° Elbow, 7L15	7E15
30° Elbow, 7L30	7E30
Rain Termination Cap, 7CC	7CC
Wall Band	BM
Supports	
Offset Support, SO	SO
Roof / Floor Support, ST	ST
Roof Brace, BS2	BS2
Firestops	
Firestop, 7BF	7BF
Radiation Shield, 7RS	7RS
Insulated Attic Radiation Shield, 7RSA	7RSA2
Insulated Wall Radiation Shield, 7RSM	7RSM
Insulated Wall Radiation Shield 30° 7RSMI30	7RSMI30
Roof Flashings	
Flat Roof Flashing, 7FR	7FR
Roof Flashing, Adjustable (5° to 30°), 7FAR	7FAR
Roof Flashing, Adjustable (30° to 45°), 7FBR	7FBR
Storm Collar, 7FC	7FC

DuraTech DTC 1" High Temp. Insulated Stainless Steel Chimney <i>7" I.D. and 11" O.D., Double-Wall Stainless Steel, Listed to CAN/UCL-S604, UL-103HT and CAN/ULC S629</i>	
Description	Part/Cat. No.
Lengths and Misc. Chimney Components	
8" length, 7" Dia.	7DTC-08SS
12" length, 7" Dia.	7DTC-12SS
18" length, 7" Dia.	7DTC-18SS
24" length, 7" Dia.	7DTC-24SS
36" length, 7" Dia.	7DTC-36SS
48" length, 7" Dia.	7DTC-48SS
Adjustable Length 12", 7" Dia.	7DTC-12TASS
15° elbow, 7" Dia.	7DTC-E15SS
30° elbow, 7" Dia.	7DTC-E30SS
Rain Termination Cap, 7" Dia.	7DTC-VC
Spark Arrester Screen (universal spark arrester band)	DTC-SA
Wall Band	DTC-WSU
Supports	
Offset Support	DTC-RESU
Roof Support	DTC-RS
Roof Brace	DTC-XRB
Firestops	
Firestop	7DTC-FS
Radiation Shield	7DTC-FRS
Insulated Attic Radiation Shield	7DTC-ISI
Insulated Wall Radiation Shield	7DTC-WTI
Insulated Wall Radiation Shield, 30°	7DTC-WRSI30
Uninsulated Wall Radiation Shield, 45°	7DTC-WRSI45
Attic Radiation Shield	7DTC-ISIA
Roof Flashings	
Flat Roof Flashing	7DTC-FF
1/12 - 7/12 (5° - 30°)	7DTC-F7
8/12 - 12/12 (30° - 45°)	7DTC-F12
Storm Collar	7DTC-SC



Report No. / Rapport n°
14-197

Serial No.

Numéro de série

Model / Modèle: WRT4826WH

Certification test emission value 4.1 g/hr per 2015 standard
Valeur d'émission du test d'homologation 4,1 g/h selon la norme 2015

**LISTED FACTORY BUILT FIREPLACE
FOYER PRÉFABRIQUÉ HOMOLOGUÉ**



Manufactured by / Fabriqué par:
INNOVATIVE HEARTH PRODUCTS
1502 14th St. NW
Auburn, WA 98001 USA

Conforms to / Conforme au : UL STD 127
Certified to / Certifié au : ULC STD S610

CLEARANCES TO COMBUSTIBLES:

SIDE WALL (FROM DOOR EDGE)	24 in. (610 mm)	MUR LATÉRAL (DE L'OUVERTURE DE LA PORTE)	24 po. (610 mm)
MANTEL (ABOVE FIREPLACE'S BASE)	54 in. (1372 mm)	LINTEAU (AU-DESSUS DE LA BASE DU FOYER)	54 po. (1372 mm)
BACK WALL AND FIREPLACE SIDE	0 in. (0 mm)	MUR ARRIÈRE ET CÔTÉ DU FOYER	0 po. (0 mm)
CEILING HEIGHT (ABOVE FIREPLACE'S BASE)	6 ft. 8 in. (2032 mm)	HAUTEUR PLAFOND (AU-DESSUS DE LA CHEMINÉE)	6 pi. 8 po. (2032 mm)
CHIMNEY	2 in. (51 mm)		2 po. (51 mm)

DÉGAGEMENTS AUX COMBUSTIBLES:

SIDE WALL (FROM DOOR EDGE)	24 po. (610 mm)
MANTEL (ABOVE FIREPLACE'S BASE)	54 po. (1372 mm)
BACK WALL AND FIREPLACE SIDE	0 po. (0 mm)
CEILING HEIGHT (ABOVE FIREPLACE'S BASE)	6 pi. 8 po. (2032 mm)
CHIMNEY	2 po. (51 mm)

INSTALL WITH MINIMUM CLEARANCES TO WALL AS SHOWN IN INCHES.

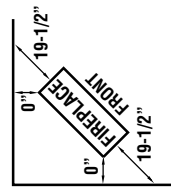
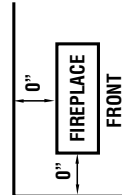

FLOOR PROTECTOR MINIMUM DISTANCE FROM OPENING IN INCHES

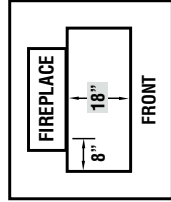

HEARTH EXTENSION MATERIAL:

- 3/8 in. THICKNESS NON COMBUSTIBLE MATERIAL
- OR EQUIVALENTS

U.S. ENVIRONMENTAL PROTECTION AGENCY

Certified to comply with 2015 particulate emission standards.
Not approved for sale after May 15, 2020.

DATE OF MFG. 1 2 3 4 5 6 7 8 9 10 11 12
2018-19-20-21-22-23-24

P/N 900441-100. REV. 0. 05/2016

- USE WOOD FUEL ONLY
- NON COMBUSTIBLE HEARTH EXTENSION MUST BE INSTALLED AT FRONT OF UNIT EXTENDING 18 in. (457 mm) AT FRONT AND 8 in. (203 mm) TO SIDES OF DOOR OPENING.
- THIS FIREPLACE HAS NOT BEEN TESTED WITH UNVENTED GAS LOG SET. TO REDUCE RISK OF FIRE OR INJURY DO NOT INSTALL AN UNVENTED GAS LOG SET INTO THE FIREPLACE.
- ELECTRICAL RATING: 120 V, 60 Hz
- CHIMNEY TYPE: USE ONLY WITH LISTED 7 in. DIAMETER CHIMNEY CERTIFIED MODEL ASHT+, S-2100+, HT6000+, HT6103+ OR ACBI Chimney.
- CAN BE CONNECTED TO A MASONRY CHIMNEY AS DESCRIBED IN THE INSTALLATION INSTRUCTIONS. COMPONENTS USED WITH THE FIREPLACE MUST BE LISTED. SEE LIST IN THE INSTALLATION INSTRUCTIONS.
- REPLACE GLASS WITH CERAMIC GLASS 5 mm THICK FOR SAFE OPERATION. INSTALL IN ACCORDANCE WITH THE MANUFACTURER'S INSTRUCTIONS.
- CAUTION: COMBUSTION AIR OPENING MUST NOT BE OBSTRUCTED.
- DO NOT OVERFIRE THE FIREPLACE.
- OPERATE THE FIREPLACE WITH DOOR FULLY OPEN OR FULLY CLOSED ONLY.
- DO NOT USE A FIREPLACE INSERT OR OTHER PRODUCTS NOT SPECIFIED FOR USE WITH THIS PRODUCT.
- BURNING OF METAL FOILS, COAL, SULFUR, OIL, PLASTIC OR GARBAGE WILL MAKE THE CATALYST IN THE COMBUSTOR INACTIVE.
- THE COMBUSTOR IS FRAGILE - HANDLE CAREFULLY.
- THE PERFORMANCE OF THE CATALYTIC DEVICE OR ITS DURABILITY HAS NOT BEEN EVALUATED AS PART OF THE CERTIFICATION.
- CONTACT YOUR LOCAL BUILDING OR FIRE OFFICIALS ABOUT RESTRICTIONS AND INSTALLATION INSPECTIONS IN YOUR AREA.
- CONTACTEZ LES RESPONSABLES DE VOTRE REGION A PROPOS DES RESTRICTIONS ET INSPECTIONS D'INSTALLATION.
- SEE IHP INSTALLATION AND OPERATING INSTRUCTIONS FOR THIS MODEL.
- INSTALL AND USE ONLY IN ACCORDANCE WITH THE MANUFACTURER'S INSTRUCTIONS AND LOCAL BUILDING CODES.
- SPECIAL METHODS ARE REQUIRED WHEN PASSING THROUGH A WALL OR CEILING. SEE INSTRUCTIONS AND BUILDING CODES.
- PREVENT CREOSOTE FIRE: INSPECT CHIMNEY CONNECTOR AND CHIMNEY FLUE MONTHLY AND CLEAN IF NECESSARY. DO NOT OVERFIRE. IF DOME OR CHIMNEY CONNECTOR GLOWS YOU ARE OVERFIRING.
- KEEP FURNISHINGS AND OTHER COMBUSTIBLE MATERIALS A CONSIDERABLE DISTANCE AWAY FROM APPLIANCE.
- MAINTENIR LES MEUBLES ET AUTRES OBJETS A UNE DISTANCE SECURITAIRE DU FOYER.
- THIS WOOD HEATER CONTAINS A CATALYTIC COMBUSTOR, WHICH NEEDS PERIODIC INSPECTION AND REPLACEMENT FOR PROPER OPERATION. IT IS AGAINST FEDERAL REGULATIONS TO OPERATE THIS WOOD HEATER IN A MANNER INCONSISTENT WITH OPERATING INSTRUCTIONS IN THIS MANUAL, OR IF THE CATALYTIC ELEMENT IS DEACTIVATED OR REMOVED.
- GET APPAREIL DE CHAUFFAGE AU BOIS CONTIENANT UN CATALYSEUR DE POSTCOMBUSTION QUI DOIT ÊTRE INSPECTÉ ET REMPLACÉ PÉRIODIQUÉMENT POUR FONCTIONNER CORRECTEMENT. L'UTILISATION DE CET APPAREIL DE CHAUFFAGE AU BOIS DE MANIÈRE INCOMPATIBLE AVEC LES INSTRUCTIONS DE CE MANUEL OU LA DESACTIVATION OU LE RETRAIT DU CATALYSEUR, CONSTITUE UNE INFRACTION AUX RÉGULATIONS FÉDÉRALES.
- POUR USAGE AVEC LE BOIS SEULEMENT
- UN TABLIER NON COMBUSTIBLE DOIT ÊTRE INSTALLÉ À L'AVANT DU FOYER EXCÉDANT DE 18 po. (457 mm) À L'AVANT ET 8 po. (203 mm) DES CÔTÉS DE L'OUVERTURE DES PORTES.
- CE FOYER N'EST PAS HOMOLOGUÉ POUR ÊTRE UTILISÉ AVEC UN ENSEMBLE DE BÛCHES À GAZ SANS CONDUIT D'ÉVACUATION. AFIN DE RÉDUIRE LES RISQUES D'INCENDIE OU DE BLESSURES, N'INSTALLEZ PAS DE BÛCHES À GAZ SANS CONDUIT D'ÉVACUATION À L'INTÉRIEUR DE CE FOYER.
- ALIMENTATION ÉLECTRIQUE: 120V, 60 Hz
- UTILISER SEULEMENT AVEC UNE CHEMINÉE 7 po. (178 mm) DE DIAMÈTRE, MODÈLE ASHT+, S2100+, HT6000+, HT6103+ OU ACBI HOMOLOGUÉE.
- PEUT ÊTRE RACCORDÉ SUR UNE CHEMINÉE DE MAÇONNERIE TEL QUE DÉCRIT DANS LE MANUEL D'INSTALLATION.
- LES COMPOSANTES UTILISÉES AVEC LE FOYER DOIVENT ÊTRE HOMOLOGUÉES. VOIR LA LISTE DANS LE MANUEL D'INSTALLATION.
- REMPLACER LA VITRE AVEC UN VERRE CÉRAMIQUE DE 5mm D'ÉPAISSEUR.
- POUR UNE UTILISATION SECURITAIRE, INSTALLER CONFORMÉMENT AUX DIRECTIVES DU FABRICANT.
- ATTENTION: NE PAS OBSTRUER LES ARRIVÉES D'AIR COMBURANT.
- NE PAS FAIRE SURCHAUFFER LE FOYER.
- LA PORTE DU FOYER DOIT DEMEURER TOTALEMENT OUVERTE OU TOTALEMENT FERMÉE LORSQUE LE FOYER FONCTIONNE.
- NE PAS UTILISER DE POÈLE ENCASTRABLE OU D'AUTRES PRODUITS NON SPÉCIFIÉS COMME ÉTANT UTILISABLES AVEC CE PRODUIT.
- LA COMBUSTION DE PAPIER D'ALUMINIUM, DE CHARBON, DE SOUFFRE, D'HUILE, DE PLASTIQUE ET DE REBUTS REND LE CATALYSEUR INACTIF.
- MANIPULER AVEC SOIN CAR LE CATALYSEUR EST FRAGILE.
- LA PERFORMANCE ET LA DURABILITÉ DU CATALYSEUR N'ONT PAS ÉTÉ ÉVALUÉS LORS DE LA CERTIFICATION.

Innovative Hearth Products Superior® Brand Wood-Burning Fireplace 20 Year Limited Warranty

THE WARRANTY

Innovative Hearth Products ("IHP") 20 Year Limited Warranty warrants your Superior® Brand wood burning fireplace ("Product") to be free from defects in materials and workmanship at the time of manufacture. The Product body, firebox and ceramic glass carry the 20 Year Limited Warranty. Ceramic glass carries the 20 Year Limited Warranty against thermal breakage only. After installation, if covered components manufactured by IHP are found to be defective in materials or workmanship during the 20 Year Limited Warranty period and while the Product remains at the site of the original installation, IHP will, at its option, repair or replace the covered components. If repair or replacement is not commercially practical, IHP will, at its option, refund the purchase price or wholesale price of the IHP product, whichever is applicable. IHP will also pay IHP prevailing labor rates, as determined in its sole discretion, incurred in repairing or replacing such components for up to five years. THERE ARE EXCLUSIONS AND LIMITATIONS to this 20 Year Limited Warranty as described herein.

COVERAGE COMMENCEMENT DATE

Warranty coverage begins on the date of purchase. In the case of new home construction, warranty coverage begins on the date of first occupancy of the dwelling or six months after the sale of the Product by an independent IHP dealer/distributor, whichever occurs earlier. The warranty shall commence no later than 24 months following the date of product shipment from IHP, regardless of the installation or occupancy date.

EXCLUSIONS AND LIMITATIONS

This 20 Year Limited Warranty applies only if the Product is installed in the United States or Canada and only if operated and maintained in accordance with the printed instructions accompanying the Product and in compliance with all applicable installation and building codes and good trade practices.

This warranty is non-transferable and extends to the original owner only. The Product must be purchased through a listed supplier of IHP and proof of purchase must be provided. The Product body and firebox carry the 20 Year Limited Warranty from the date of installation. Vent components, trim components, paint and applied stains are excluded from this 20 Year Limited Warranty. The following do not carry a 20 Year Limited Warranty but are warranted as follows:

Air tubes, baffles and brick retainers – Repair or replacement for one year from the date of installation

Cast iron parts – Replacement for one year from date of installation

Catalyst – Carries a separate warranty. Refer to the warranty certificate provided for that part

Electrical components – Repair or replacement for one year from the date of installation

Fireplace screens, refractory and side shields (metal or refractory) – Repair or replacement for two years from date of installation. Excludes hairline cracks.

Fuel grates – These parts are considered consumable accessories and therefore are not warranted, with the exception of defects in material or workmanship which are covered for 90 days from the date of installation

Gaskets – Replacement for one year from date of installation

Gold & nickel plating – Replacement for two years from date of installation. Excludes tarnishing

Optional glass doors – Repair or replacement for 90 days from the date of installation

Refractory & screens – Replacement for two years from date of installation. Excludes hairline cracks

Removable air tubes – Repair or replacement for seven years from date of installation. IHP prevailing labor rates for years one through five.

Labor coverage – Prevailing IHP labor rates apply for the warranty period of the component.

Parts not otherwise listed carry a 90 day warranty from the date of installation.

Whenever practicable, IHP will provide replacement parts, if available, for a period of 10 years from the last date of manufacture of the Product.

IHP will not be responsible for: (a) damages caused by normal wear and tear, accident, riot, fire, flood or acts of God; (b) damages caused by abuse, negligence, misuse, or unauthorized alteration or repair of the Product affecting its stability or performance. (The Product must be subject to normal use with approved fuels listed in the Operation Manual provided with the product. This includes burning such fireplace fuels as wood and natural or propane gas. Fuel products with abnormal burning characteristics, including but not limited to fuel such as driftwood, coal or plywood and wood products using a binder may burn at excessive temperatures and may cause damage to the Product or may cause it to function improperly.); (c) damages caused by failing to provide proper maintenance and service in accordance with the instructions provided with the Product; (d) damages, repairs or inefficiency resulting from faulty installation or application of the Product.

Coverage of this 20 Year Limited Warranty is conditional upon use of an adequate fuel grate on factory-built fireplaces only, when applicable.

IHP is not responsible for inadequate fireplace system draft caused by air conditioning and heating systems, mechanical ventilation systems, or general construction conditions which may generate negative air pressure in the room in which the appliance is installed. Additionally IHP assumes no responsibility for smoking conditions caused by inadequate chimney height, adjoining trees or buildings, adverse wind conditions or unusual environmental factors and conditions. Certain IHP Products are listed for use with Security Chimneys International, Ltd. or IHP chimney systems only. Use of chimney components other than that specified in the Product manual will void the Product warranty.

This 20 Year Limited Warranty covers only parts and labor as provided herein. In no case shall IHP be responsible for materials, components or construction which are not manufactured or supplied by IHP or for the labor necessary to install, repair or remove such materials, components or construction. Additional utility bills incurred due to any malfunction or defect in equipment are not covered by this 20 Year Limited Warranty. All replacement or repair components will be shipped F.O.B. from the nearest stocking IHP factory.

LIMITATION ON LIABILITY

It is expressly agreed and understood that IHP's sole obligation and the purchaser's exclusive remedy under this warranty, under any other warranty, expressed or implied, or in contract, tort or otherwise, shall be limited to replacement, repair, or refund, as specified herein.

In no event shall IHP be liable for any incidental or consequential damages caused by defects in the Product, whether such damage occurs or is discovered before or after replacement or repair, and whether such damage is caused by IHP's negligence. IHP has not made and does not make any representation or warranty of fitness for a particular use or purpose, and there is no implied condition of fitness for a particular use or purpose.

IHP makes no expressed warranties except as stated in this 20 Year Limited Warranty. The duration of any implied warranty is limited to the duration of this expressed warranty.

No one is authorized to change this 20 Year Limited Warranty or to create for IHP any other obligation or liability in connection with the Product. Some states and provinces do not allow the exclusion or limitation of incidental or consequential damages, so the above limitations or exclusions may not apply to you. The provisions of this 20 Year Limited Warranty are in addition to and not a modification of or subtraction from any statutory warranties and other rights and remedies provided by law.

INVESTIGATION OF CLAIMS AGAINST WARRANTY

IHP reserves the right to investigate any and all claims against this 20 Year Limited Warranty and to decide, in its sole discretion, upon the method of settlement.

To receive the benefits and advantages described in this 20 Year Limited Warranty, the appliance must be installed and repaired by a licensed contractor approved by IHP.

Contact IHP at the address provided herein to obtain a listing of approved dealers/distributors. **IHP shall in no event be responsible for any warranty work done by a contractor that is not approved without first obtaining IHP's prior written consent.**

HOW TO REGISTER A CLAIM AGAINST WARRANTY

In order for any claim under this warranty to be valid, you must contact the IHP dealer/distributor from which you purchased the product. If you cannot locate the dealer/distributor, then you must notify IHP in writing. IHP must be notified of the claimed defect in writing within 90 days of the date of failure. Notices should be directed to the IHP Warranty Department at 1769 East Lawrence Street; Russellville, AL 35654 or visit our website at WWW.SUPERIORFIREPLACES.US.COM.

WARRANTY

Your fireplace is covered by a limited warranty. Please read the warranty to be familiar with its coverage.

Retain this manual. File it with your other documents for future reference.

PRODUCT REFERENCE INFORMATION

We recommend that you record the following important information about your fireplace. Please contact your IHP dealer for any questions or concerns.

REPLACEMENT PARTS

See **Page 28** for a complete replacement parts list. Use only parts supplied from the manufacturer.

Normally, all parts should be ordered through your IHP distributor or dealer. Parts will be shipped at prevailing prices at time of order.

When ordering repair parts, always give the following information:

1. The model number of the appliance.
2. The serial number of the appliance.
3. The part number.
4. The description of the part.
5. The quantity required.
6. The installation date of the appliance.

If you encounter any problems or have any questions concerning the installation or application of this system, please contact your dealer.

IHP
1769 East Lawrence Street
Russellville, AL 35654
SuperiorFireplaces.us.com

Model Number _____
Serial Number _____
Date Installed _____
Dealer's Name _____
Dealer's Phone Number _____

 <p>NATIONAL FIREPLACE INSTITUTE NFI CERTIFIED www.nficertified.org</p>	<p>We recommend that our woodburning hearth products be installed and serviced by professionals who are certified in the U.S. by the National Fireplace Institute® (NFI) as NFI Woodburning Specialists or who are certified in Canada by Wood Energy Technical Training (WETT).</p>	 <p>Wood Energy Technical Training www.wettinc.ca</p>
-----------------------------------------------------------------------------------------------------------------------------------------------------------------------------------------------------------------------------------------------	--------------------------------------------------------------------------------------------------------------------------------------------------------------------------------------------------------------------------------------------------------------------------------------	----------------------------------------------------------------------------------------------------------------------------------------------------------------------------------------------

Innovative Hearth Products (IHP) reserves the right to make changes at any time, without notice, in design, materials, specifications, prices and also to discontinue colors, styles and products. Consult your local distributor for fireplace code information.

