

Superior
FIREPLACES®
Our name is our promise.



The WCT6940 beautifully combines the craftsmanship of a traditional masonry fireplace with the power of clean controllable combustion heating. The gorgeous door and facade allow you to achieve a customized look that reflects your style. With outstanding heat output and high-efficiency operation, the WCT6940 wood-burning fireplace excels.



FEATURED WCT6940 shown with White Textured Stacked Panels

EXCLUSIVE FEATURES

- 🔥 Circulating design features facade, arch doors and ceramic glass for optimum heat transfer
- 🔥 EPA variable-rate certified and Washington State approved high-efficiency wood heater
- 🔥 Spacious 4.0 cubic foot insulated firebox that accepts up to 30" log size for increased performance
- 🔥 Steel double doors with heat resistant door handles that stay cool to the touch
- 🔥 White stacked textured refractory panels with integrated ash lip and decorative cast iron log retainer
- 🔥 Catalytic combustor for maximum performance
- 🔥 Bypass control: Greater airflow during startup for faster wood ignition and no smoke spillage when reloading
- 🔥 Includes insulated outside air kit (required for use)
- 🔥 80,000 BTUs and heats up to 2,500 square feet*
- 🔥 Efficient air wash system that keeps glass clean
- 🔥 Includes heat activated 200 CFM variable-speed blower for time-delayed heat distribution
- 🔥 Durable high temperature paint finish
- 🔥 20 Year Limited Warranty

*Square-foot heating capacities are approximations only. Actual performance may vary depending upon home design and insulation, ceiling heights, climate, condition and type of wood used, appliance location, burn rate, accessories chosen, chimney installation and how the appliance is operated.

ADVANCED COMBUSTION SYSTEM

- **FULL CONTROL OF BURN RATE** allows for long overnight burns, a big advantage over single-rate systems
- **COMBINES THE BENEFITS** of both catalytic technology and a secondary air combustion system
- **MAXIMUM COMBUSTION** efficiency produces more heat while reducing emissions
- **EASY ACCESS BYPASS CONTROL** allows smoke direct access to chimney for startup and reloading

ENGINEERING FEATURES AND SPECIFICATIONS

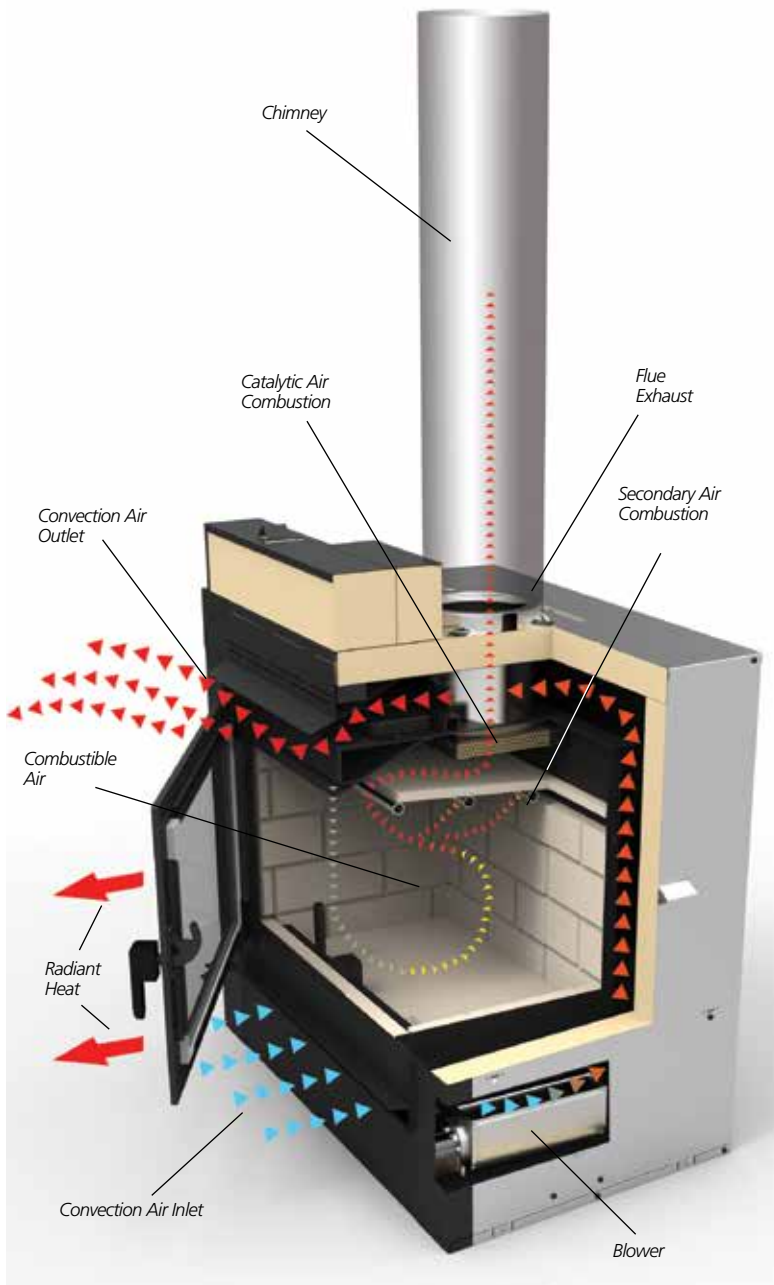

FORCED AIR KIT

Share the warmth. The optional Forced Air Kit provides up to **25% more heat** from the same fire. This additional heat can be distributed **up to 25 feet**, to three additional rooms, including rooms on a lower floor. The included thermostat allows automatic control of heat distribution for balanced and controlled comfort.

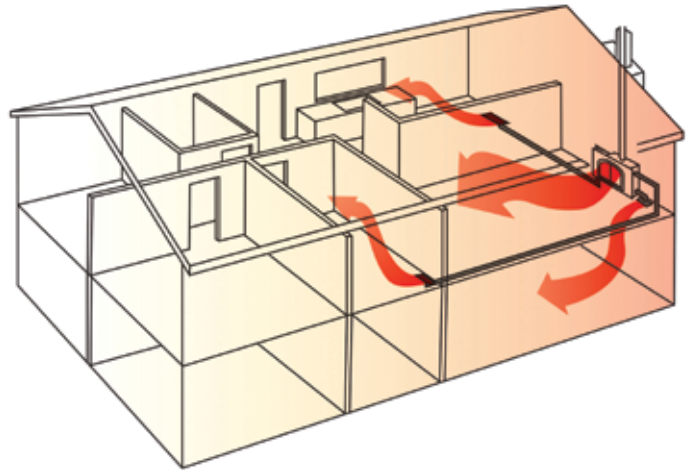

ADDITIONAL ACCESSORIES

- Forced Air Kit for forced air zone heating to multiple locations

INTERIOR

(Standard)



White Textured Stacked Panels

DOORS

(Required)



Smooth

FACADES

(Required)



Smooth

APPLIANCE SPECIFICATIONS

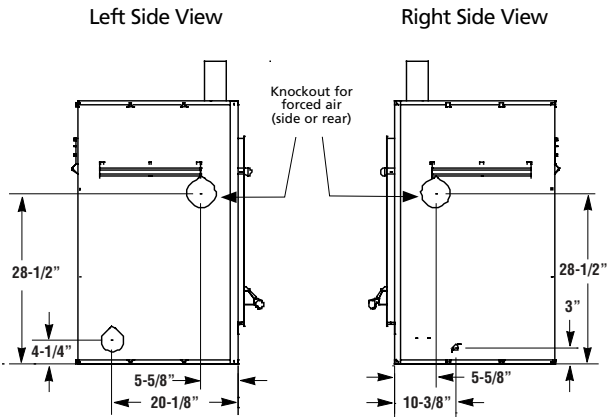
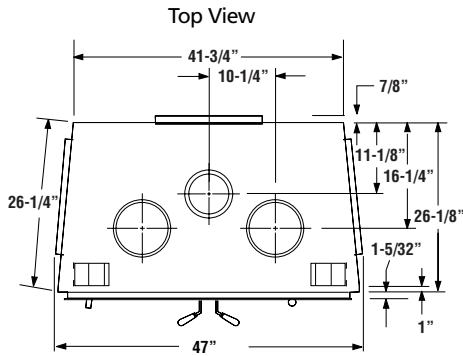
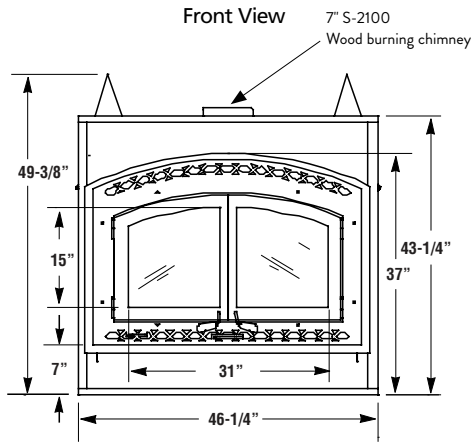

IMPORTANT NOTES:

As with any fireplace, this appliance is extremely hot during operation. Read and understand all operating instructions before using this appliance. For further information, consult your dealer.

Local conditions, such as elevation and choice of fuel will affect overall appearance of the fire and heating performance. Performance can also vary with home design and insulation, ceiling height, accessories chosen and appliance location.

Diagrams, illustrations and photographs are not to scale — consult installation instructions. Product designs, materials, dimensions, specifications, colors and prices are subject to change or discontinuance without notice.

FRAMING SPECIFICATIONS

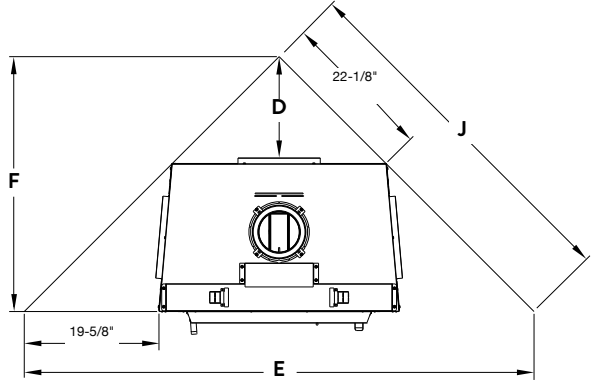
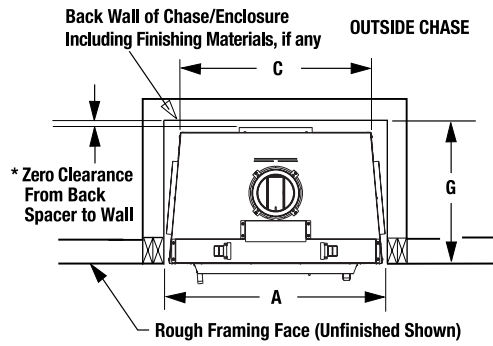

A	C	D	E	F	G	J
36"	31-3/8"	14-7/8"	74-3/8"	37-1/4"	*22"	52-5/8"
915mm	797mm	378mm	1889mm	946mm	559mm	1337mm

* Total depth is 22-1/2" (572mm) including the back spacer minus 1/2" (13mm) for drywall to be flush with the facing.

PRODUCT SPECIFICATIONS

Glass Viewing Area (W x H)	31" x 15"
Firebox Interior (W x H x D+)	31" x 14-1/2" x 14"
Interior Cubic Feet	4.0
Maximum Log Size	30"
Chimney Size	7"
EPA Rating	1.3 grams/hr
Max BTU's	80,000
Heating Capacity (up to)	2,500 sq. ft.
Thermal Efficiency	70%
Blower	350 CFM
Weight	520 lbs.

+Measured in front of door



© 2020 Innovative Hearth Products

785680M 10/20



Report #14-198