



OWNER'S MANUAL

INSTALLATION INSTRUCTIONS

VISITEZ NOTRE SITE WEB POUR LA VERSION FRANÇAISE DE CE MANUEL
VISITE NUESTRA PÁGINA WEB PARA LA VERSIÓN EN ESPAÑOL DE ESTE MANUAL
<https://www.williamscomfortprod.com/products/furnaces/>

FORSAIRE™ COUNTERFLOW TOP VENT GAS WALL HEATER

MODEL NUMBERS: (natural gas)
3508632 / 3508232 / 5008632 / 5508232 / 6508632

MODEL NUMBERS: (propane gas)
3508631 / 3508231 / 5008631 / 5508231 / 6508631

SAVE THIS MANUAL FOR FUTURE REFERENCE.

READ THIS OWNER'S MANUAL CAREFULLY BEFORE YOU
INSTALL YOUR NEW WILLIAMS WALL FURNACE.

DISCONTINUED MODEL NUMBERS:
3518232 / 3538232 / 3558232 / 3518231 / 3538231 / 3558231
35186232 / 3538632 / 3558632 / 3518631 / 3538631 / 3558631
5518232 / 5538232 / 5558232 / 5518231 / 5538231 / 5558231
6518632 / 6538632 / 6558632 / 6518631 / 6538631 / 6558631
6518232 / 6538232 / 6558232 / 6518231 / 6538231 / 6558231



35,000 - 65,000 BTU/hr.

⚠ WARNING: This product can expose you to chemicals including epichlorohydrin which is known to the State of California to cause cancer and birth defects and/or other reproductive harm. For information go to www.p65warnings.ca.gov

⚠ WARNING: Improper installation, adjustment, alteration, service or maintenance can cause injury or property damage. Refer to this manual. For assistance or for additional information consult a qualified installer or service agency.

⚠ WARNING: If the information in these instructions is not followed exactly, a fire or explosion may result causing property damage, personal injury or loss of life.

- Do not store or use gasoline or other flammable vapors and liquids in the vicinity of this or any other appliance.

WHAT TO DO IF YOU SMELL GAS:

- Open all windows.
- Do not try to light any appliance.
- Do not touch any electrical switch; do not use any phone or cell phone in your building.
- Extinguish any open flame.
- Immediately call your gas supplier from a neighbor's phone. Follow the gas supplier's instructions.
- If you cannot reach the gas supplier, call the fire department.
- Installation and service must be performed by a qualified installer, service agency or the gas supplier.



WARRANTY

The manufacturer, Williams Furnace Co., warrants this wall furnace or heater to the original purchaser under the following conditions: **ANY WARRANTY CONSIDERATIONS ARE CONTINGENT ON INSTALLATION BY A QUALIFIED INSTALLER (CONTRACTOR). SELF-INSTALLATION IS PROHIBITED AND WILL INVALIDATE YOUR WARRANTY.**

LIMITED ONE-YEAR WARRANTY

1. Any part thereof which proves to be defective in material or workmanship within one year from date of original purchase for use will be replaced at the Manufacturer's option, FOB to its factory.
2. No liability is assumed by the Manufacturer for removal or installation labor costs, nor for freight or delivery charges.

LIMITED EXTENDED WARRANTY

1. In addition to the above limited one year warranty on the complete unit, any combustion chamber which burns out or rusts under normal installation, use and service conditions during a period of nine years following expiration of the one-year warranty period will be exchanged for a like or functionally similar part.
2. No liability is assumed by the Manufacturer for removal or installation labor costs, nor for freight or delivery charges.

LIMITATIONS

1. THIS LIMITED WARRANTY IS THE ONLY WARRANTY MADE BY THE MANUFACTURER, IMPLIED WARRANTIES OF MERCHANTABILITY OR FITNESS FOR ANY PARTICULAR PURPOSE ARE LIMITED TO THE SAME ONE YEAR TERM AS THE EXPRESS WARRANTY. UNDER NO CIRCUMSTANCES SHALL THE MANUFACTURER BE LIABLE FOR INCIDENTAL, CONSEQUENTIAL, SPECIAL OR CONTINGENT DAMAGES OR EXPENSES ARISING DIRECTLY OR INDIRECTLY FROM ANY DEFECT IN THE PRODUCT OR ANY COMPONENT OR FROM THE USE THEREOF. THE REMEDIES SET FORTH HEREIN ARE THE EXCLUSIVE REMEDIES AVAILABLE TO THE USER AND ARE IN LIEU OF ALL OTHER REMEDIES.

Some states do not allow limitation on how long an implied warranty lasts, and some states do not allow the exclusion or limitation of incidental or consequential damages, so the above limitations or exclusions may not apply to you.

2. This warranty does not include any charge for labor or installation.
3. This warranty does not extend to painted surfaces or to damage or defects resulting from accident, alteration, misuses or abuse or improper installation.
4. This warranty does not cover claims which do not involve defective workmanship or materials.

DUTIES OF THE CONSUMER

1. The heating equipment must be installed by a qualified installer and operated in accordance with the installation and homeowner's instructions furnished with the equipment.
2. Any travel, diagnostic costs, service labor, and labor to repair the defective unit will be the responsibility of the owner.
3. A bill of sale, canceled check, payment record or permit should be kept to verify purchase date to establish the warranty period.
4. Have the installer enter the requested information in the space below.

GENERAL

1. The manufacturer neither assumes nor authorizes any person to assume for it any other obligation or liability in connection with said equipment.
2. Service under this warranty should be obtained by contacting your dealer. Provide the dealer with the model number, serial number, and purchase date verification.
3. If, within a reasonable time after contacting your dealer, satisfactory service has not been received, contact: Customer Service Department, 250 West Laurel Street, Colton, CA 92324 for assistance.
4. THIS WARRANTY GIVES YOU SPECIFIC LEGAL RIGHTS AND YOU MAY ALSO HAVE OTHER RIGHTS WHICH VARY FROM STATE TO STATE.

INSTALLATION RECORD

Model No. _____ Serial No. _____

Original Purchaser _____

Address _____

City and State _____ Zip _____

Dealer _____

Address _____

City and State _____ Zip _____

Installation Date _____ Name _____ Signature _____

(Dealer or authorized representative who certifies that this appliance is installed in accordance with Manufacturer's instructions and local codes.)

CONTENTS

YOUR WILLIAMS WARRANTY	2
INSTALLATION RECORD	2
TABLE OF CONTENTS	3
SAFETY RULES	4
INTRODUCTION	5
BASIC MATERIALS NEEDED	6
BASIC TOOLS NEEDED	6
HELPFUL INSTALLATION INFORMATION	6
OPTIONAL ACCESSORIES	6
UNPACKING YOUR FURNACE	6
INSTALLING YOUR WALL FURNACE	7
LOCATING WALL FURNACE AND THERMOSTAT	7
COMBUSTION & VENTILATION AIR	8
INSTALLATION	7-19
RECESSED MOUNT INSTALLATION	11
SURFACE MOUNT INSTALLATION	13
GENERAL VENT INSTALLATION	14
MOUNTING YOUR FURNACE	16
GAS SUPPLY AND PIPING	17
ELECTRICAL WIRING	19
THERMOSTAT INSTALLATION	20
START UP PROCEDURE	21
SAFETY CONTROLS	22
OPERATING YOUR FURNACE	23
CARING FOR YOUR FURNACE	24
FORSAIRE HARDWIRE ACCESSORY 9940	26
WIRING DIAGRAMS	27
PART NUMBERS FOR THE 350 MODEL	29
CONTROL ASSEMBLY REPLACEMENT PARTS 350 MODEL INTERMITTEN IGNITION	31
CONTROL ASSEMBLY REPLACEMENT PARTS 350 MODEL STANDING PILOT	32
PART NUMBERS FOR THE 500 / 550 / 650 MODELS	33
CONTROL ASSEMBLY REPLACEMENT PARTS 550 MODELS - INTERMITTEN IGNITION	35
CONTROL ASSEMBLY REPLACEMENT PARTS 500 / 650 MODELS - STANDARD PILOT	36
TROUBLESHOOTING YOUR FURNACE	37
INSTALLATIONS IN THE STATE OF MASSACHUSETTS	40
HINTS AND INFORMATION	41
SERVICE RECORD	42

Quick Reference Here's how to:

INSTALLING YOUR FURNACE Recessed Mount, Surface Mount, and Vent Installation are explained starting on page 8 .	7
OPERATING YOUR FURNACE Igniting your furnace for the first time.	23
HOW TO CARE FOR YOUR FURNACE Learn how to keep your new Williams Furnace operating.	24

SAFETY RULES

⚠ WARNING: Read these rules and the instructions carefully. Failure to follow these rules and instructions could cause a malfunction of the furnace. This could result in death, serious bodily injury and/or property damage.

INSTALLATION MUST CONFORM TO LOCAL CODES. IN THE ABSENCE OF LOCAL CODES, INSTALLATION MUST CONFORM TO THE NATIONAL FUEL GAS CODE, ANSI Z223.1. THE APPLIANCE, WHEN INSTALLED MUST BE ELECTRICALLY CONNECTED AND GROUNDED IN ACCORDANCE WITH LOCAL CODES OR, IN THE ABSENCE OF LOCAL CODES, WITH THE CURRENT NATIONAL ELECTRICAL CODE ANSI/NFPA NO. 70.

IN CANADA:

1. Installation must conform to local codes or, in the absence of local codes, the current CAN/CGA B149 installation code.
2. The appliance, when installed, must be electrically connected and grounded in accordance with local codes or, in the absence of local codes, with the current CSA C22.1 Canadian Electrical code.
3. Reference is made in this manual regarding gas type as propane gas. Be advised that propane gas is not available in Canada, refer to propane gas.

1. Use only manufacturer's replacement parts. Use of any other parts could cause injury or death.
2. DO NOT install the furnace in an alcove.
3. DO NOT install this furnace where it could be isolated by closing doors to the heated space.
4. DO NOT install this furnace in a travel trailer or recreational vehicle.
5. MAINTAIN all clearances specified in section "Locating Wall Furnace and Thermostat" and "Vent Installation."
6. BE SURE this furnace is for type of gas to be used. Check the rating plate by the gas valve in the lower cabinet. Do not change it to use other gases without the proper manufacturer's Gas Conversion Kit.
7. For natural gas, the minimum inlet gas supply pressure for the purpose of input adjustment is 5" water column. The maximum inlet gas supply pressure is 7" water column.
For propane gas, the minimum inlet gas supply pressure for the purpose of input adjustment is 11" water column.
The maximum inlet gas supply pressure is 13" water column.
8. Any safety screen, guard or parts removed for servicing this appliance must be replaced prior to operating the appliance to avoid property damage, bodily injury or death.
9. Install the furnace vent directly to the outdoors so that harmful combustible flue gases will not collect inside the building. Follow the venting instructions for your

type of installation exactly. Use only the type and size of vent pipe and fittings specified.

10. BE SURE to provide for adequate combustion and ventilation air. The flow of this air to the furnace must not be blocked.
11. NEVER vent flue gases into another room, a fireplace or any space inside a building. This could cause property damage, bodily injury or death.
12. Never test for gas leaks with an open flame. Use a soap solution to check all gas connections. This will avoid the possibility of fire or explosion.
13. ALLOW the furnace to cool before servicing. Always shut off electricity and gas to furnace when working on it. This will prevent any electrical shocks or burns.
14. DUE TO HIGH TEMPERATURES, locate the furnace out of traffic and away from furniture and draperies.
15. ALERT children and adults to the hazards of high surface temperatures and warn them to keep away to avoid burns or clothing ignition.
16. CAREFULLY supervise young children when they are in the same room with the furnace.
17. DO NOT place clothing or other flammable material on or near furnace.
18. INSTALLATION and REPAIR must be done by a qualified service person. The appliance should be inspected before use and at least annually by a professional service person. More frequent cleaning may be required due to excessive lint from carpeting, bedding material, etc. It is imperative that control compartments, burners and circulating air passages be kept clean.
19. BEFORE INSTALLING: To avoid electrical shock, turn off electrical circuits that pass through the wall where you are going to install the furnace.
20. BE AWARE of good safety practices by wearing personal protective equipment such as gloves and safety glasses to avoid being injured by sharp metal edges in or around furnace and while cutting or drilling holes in wood and/or sheet metal.
21. **CAUTION:** Label all wires prior to disconnection when servicing controls.

⚠ WARNING: Do not use this furnace if any part has been under water. Immediately call a certified service technician to inspect the furnace and to replace any part of the control system and any gas control which has been under water.

⚠ WARNING: Do not install any of these furnaces (natural or propane gas) in mobile homes, trucks or recreational vehicles.

INTRODUCTION

BASIC DESCRIPTION

The following steps are all needed for proper installation and safe operation of your furnace. If you have any doubts as to any requirements, check with local authorities. Obtain professional help where needed. All of the checks and adjustments in the "Start-Up Procedures" are vital to the proper and safe operation of your furnace. Please read our instructions before you install and use your furnace. This will help you obtain the full value from this furnace. It could also help you avoid needless service costs if the answer to the problem is found within this instruction manual.

Always consult your local heating or plumbing inspector, building department or gas utility company regarding regulations, codes or ordinances which apply to the installation of a counterflow top vented wall furnace.

Check the furnace nameplate, located in the burner compartment, to make sure the furnace is equipped to operate on the type of gas available (either natural or propane gas).

DO NOT convert the furnace from natural gas to propane gas or from propane gas to natural gas without the proper manufacturer's gas conversion kit.

Your Counterflow Top Vent Furnace draws air in at the top of the furnace by the fan and discharged through the grille near the floor. It is shipped ready to install on the surface of a wall or recessed into a wall. Combustion air is drawn in from the room where the furnace is located and vented out the top of the furnace through listed vent piping to a roof top vent. Venting material is not supplied with this furnace.

This appliance is equipped with a vent safety shutoff system designed to protect against improper venting of combustion products. Operation of this wall furnace when not connected to a properly installed and maintained venting system or tampering with the vent safety shutoff system can result in carbon monoxide (CO) poisoning and possible death.

WARNING: CARBON MONOXIDE POISONING HAZARD

Failure to follow the steps outlined below for each appliance connected to the venting system being placed into operation could result in carbon monoxide poisoning or death.

The following steps shall be followed for each appliance connected to the venting system being placed into operation, while all other appliances connected to the venting system are not in operation:

- 1) Seal any unused openings in the venting system.
- 2) Inspect the venting system for proper size and horizontal pitch, as required in the National Fuel Gas Code, ANSI Z223.1/NFPA 54 or the Natural Gas and Propane Installation Code, CSA B149.1 and these instructions. Determine that there is no blockage or restriction, leakage, corrosion and other deficiencies which could cause an unsafe condition.
- 3) As far as practical, close all building doors and windows and all doors between the space in which the appliance(s) connected to the venting system are located and other spaces of the building.
- 4) Close fireplace dampers.
- 5) Turn on clothes dryers and any appliance not connected to the venting system. Turn on any exhaust fans, such as range hoods and bathroom exhausts, so they are operating at maximum speed. Do not operate a summer exhaust fan.
- 6) Follow the lighting instructions. Place the appliance being inspected into operation. Adjust the thermostat so appliance is operating continuously.
- 7) Test for spillage from draft hood equipped appliances at the draft hood relief opening after 5 minutes of main burner operation. Use the flame of a match or candle.
- 8) If improper venting is observed during any of the above tests, the venting system must be corrected in accordance with the National Fuel Gas Code, ANSI Z223.1/NFPA 54 and/or Natural Gas and Propane Installation Code, CSA B149.1.
- 9) After it has been determined that each appliance connected to the venting system properly vents when tested as outlined above, return doors, windows, exhaust fans, fireplace dampers and any other gas-fired burning appliance to their previous conditions of use.

INTRODUCTION

Basic Tools Needed

- Hand drill or properly grounded electric drill
- Expansion bit 1/2" to 1-5/8" or 1/2" and 1-1/2" blade bits
- 1/8" and 3/16" drill bit (metal)
- 6 ft. folding rule or tape measure
- Screwdriver (medium blade)
- Screwdriver (Phillips and Flat Head)
- Pliers (wire cutting)
- Hammer
- Stud Locater or small finishing nails
- Tin Snips
- 8" adjustable wrench
- 12" adjustable wrench
- 7/8" wrench
- 3/4" wrench
- 1" wrench
- Gloves and safety glasses

Materials

Pipe and fittings to make connections to furnace **See page 19.**

Caulking compound (silicone rubber with a temperature rating of 500°F.

DO NOT use caulking compound advertised as paintable or for bath tub use as most contain fillers and will not withstand high temperatures.

Pipe Joint Compound resistant to propane gases.

Electrical wiring supplied as needed **see page 27.** Minimum wire size is #14 gauge copper.

Trim Accessory 4701 is recommended or 3/4" Quarter Round or other wood trim molding approximately 16' long.

Oval Vent Kit 9901 is recommended.

Vent Enclosure Kit 9812 or 9824 if furnace is to be surface mounted is recommended.

1 x 1 wood strips if Optional Side Outlet Grille Register 6701 is used.

Helpful Installation Information

The following booklets will help you in making the installation: ANSI/NFPA 70 (1990 or current edition "National Electrical Code").

In Canada: CSA C22.1 Canadian Electrical Code. American National Standard NFPA 70/ANSI Z223.1 1988 or current edition "National Fuel Gas Code".

Obtained from: American National Standards Institute, Inc., 1430 Broadway, New York, N Y 10018.

In Canada: CAN/CGA B149.

Optional Accessories

DIFFUSER GRILLE KITS 6703 & 6704

6703 lets you route some heated air in a two-way direction. Kit 6704 for one-way direction.

SIDE OUTLET GRILLE KIT 6702

Allows you to direct heated air from the side of furnace into the same room.

OUTLET GRILLE REGISTER 6701

Lets you route some heated air into a second room. Mounts on the side wall of second room and must be within 10 inches of wall furnace.

REAR OUTLET KITS 6801 & 6802

Lets you route some heated air into a second room behind the furnace. Finished wall of second room must be within 10 inches of furnace as shown on **Page 8, Figure D.** Built-in damper lets you shut off air flow to second room if desired.

OVAL VENT KIT 9929

This U.L. listed B/W vent kit contains 4 feet of oval double walled vent pipe, plate spacers and starter or hold-down plate that starts the venting from the top of the furnace. **See page 15** for additional items you will need.

VENT ENCLOSURE KITS 9812 or 9824

These kits are used only when the furnace is surface mounted. They enclose the vent pipe from the top of the surface to the ceiling.

TRIM STRIP KIT 4701

Provides finished edge at sides of wall furnace. Neutral beige enamel painted steel.

THERMOSTAT P322016

Unpacking Your Furnace

The furnace is shipped in one carton containing the furnace, installation instruction booklet and hardware bag.

1. Lay carton horizontally. Open carton and remove top trim cover from its packing. Remove thumb screw at top of furnace, raise top front panel 1/2 inch and remove panel from cabinet. This is so you can get to the electrical connections later.
2. Place these and other parts, as they are removed from furnace, where they cannot be lost or damaged before you need them.
3. Bottom front panel can be removed by grasping just below handle and pulling it outward and then upward. **See Figure 1.**

NOTE

Check the burner rating plate, located in burner compartment, to make sure your furnace is equipped to operate on the type of gas available (either natural or propane gas).

4. Remove all literature, wire and metal anchors used for free standing installation.
5. Check the fan blade to be sure it spins freely.

INSTALLING YOUR FURNACE

Locating Wall Furnace & Thermostat

Consider the following points before attempting to install the furnace:

CAUTION: Do not make cut-outs in the wall or ceiling before checking in the attic for ceiling joist locations and proposed venting.

The counterflow vented wall furnaces are shipped ready to install on the surface of the wall or recessed up to 9-1/4 inches into the wall, with studs 16 inches center-to-center or stud space can be framed to 16 inches, **see page 12, Recessed Mounting.**

Place the furnace near the center of the space to be heated for good air circulation. Do not put it behind a door or draperies.

Do not install the furnace in a closet, alcove, or small hallway where the furnace could be isolated by closing doors to the heater space.

Do not install the furnace in a mobile home, trailer, or recreational vehicle.

The bottom of the furnace may rest directly on a wood or concrete floor. If floor is other than wood or concrete there must be a piece of wood or sheet metal under the furnace that is at least the same size as the bottom of the furnace.

On recessed installations the recessed portion may have 0 inches clearance to combustible material.

To provide adequate clearance and service access the front of the furnace must face the open room. Be sure that gas piping and electrical wiring can be brought to the location. See sections covering piping and electrical wiring for your type of furnace mounting.

Furnace vent must be installed directly to the outdoors so that combustion gases will not collect inside the building.

Provide an adequate vent or flue in accordance with local codes or ordinances and instructions provided by the vent pipe manufacturer.

Check the minimum spacing needs as shown on **Page 8, Figure 2 and Page 8, Figure 3.**

The top of the furnace must be at least 4 inches from the ceiling. **See Figure 2.**

With standard furnace discharge outlet, do not install closer than 4 inches to intersecting wall. See figure as shown on **Page 8, Figure 3B.**

When using optional kits 6703 or 6704 maintain clearances as shown on **Page 8, Figure 3A or 3C.**

When using optional kit 6704 maintain clearance as shown in **Figures 3A and 3F, page 8.** Use only optional outlet and grille kits available from manufacturer.

FIGURE 1

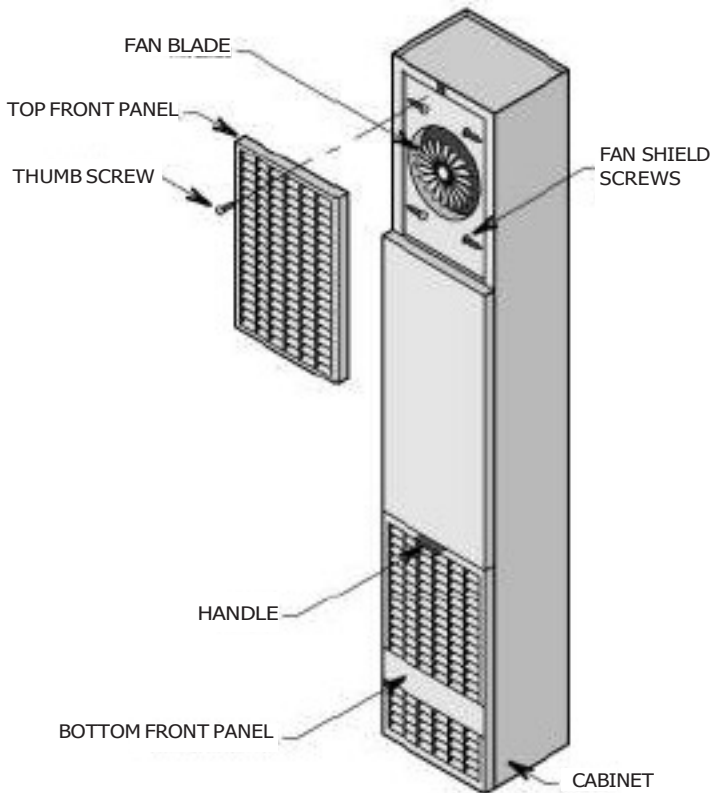

The following steps are needed for proper installation and safe operation of your furnace. If you have any doubts as to any requirements, always consult your local Heating or Plumbing Inspector, Building Department or Gas Utility Company regarding regulations, codes, or ordinances which apply to the installation of a vented wall furnace. Obtain professional help where needed.

The **CHECK AND ADJUSTMENTS on page 24** are vital to the proper and safe operation of the furnace. Be sure they are done.

IMPORTANT

For satisfactory and trouble-free operation, be sure to:

1. Locate the furnace properly within the space to be heated.
2. Install the furnace in accordance with local codes or ordinances and instructions provided. In the absence of local codes or ordinances, install the furnace to conform with the current edition of the National Fuel Gas Code, NFPA 54, ANSI Z223.1/Canadian Installation Code, CAN/CGA B149.
3. Maintain minimum clearance: Floor 0 inches or ceiling 4 inches, side wall 4 inches. For exception to minimum side wall clearance, as shown on **Page 8, Figure 3.**
4. Provide enough combustion and ventilation air.

INSTALLING YOUR FURNACE

FIGURE 2 MINIMUM CLEARANCES

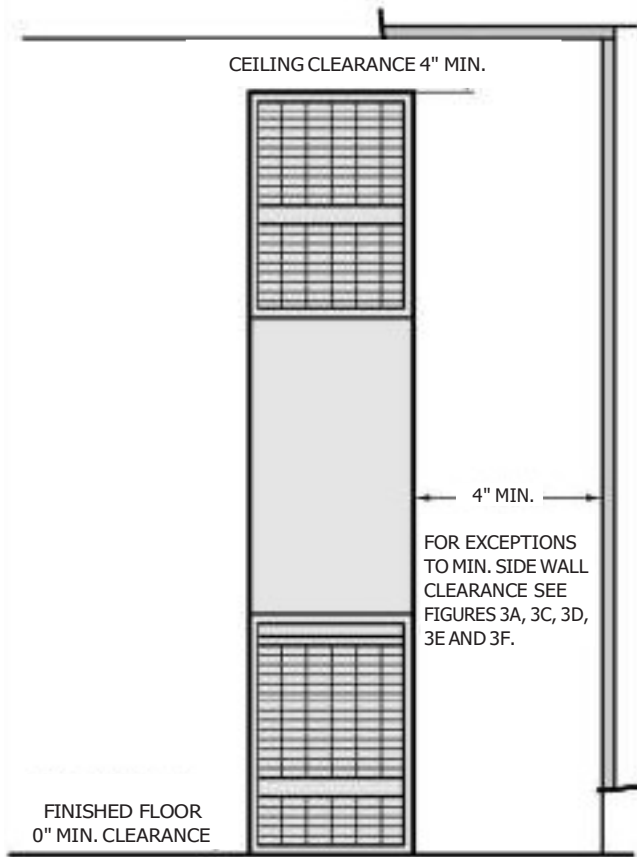

With standard furnace discharge outlet, do not install closer than 4 inches to intersecting wall.

Choose a location for the thermostat (optional) about 5 feet above the floor on an inside wall. The thermostat wire supplied with your furnace is 20 feet long, which should be enough to run up through the attic so the thermostat can be a maximum of 16 feet from the furnace measured in a straight line, or approximately 12 feet from the furnace if the wire is run under the floor. The thermostat should be sensing average room temperature, avoid the following:

HOT SPOTS:

- Concealed pipes or ducts
- Fireplaces
- Registers
- TV sets
- Radios
- Lamps
- Direct sunlight
- Kitchen

COLD SPOTS:

- Concealed pipes or ducts
- Stairwells – drafts
- Doors – drafts
- Unheated rooms on other side of wall

DEAD SPOTS

- Behind doors
- Corners, and alcoves

After picking a location that meets the requirements, check the walls, attic and roof to make sure there are no obstructions such as pipes, electric wiring, etc., which could interfere with the installation of the furnace or vent pipe. If required, move them or pick a new location.

FIGURE 3 MINIMUM CLEARANCES

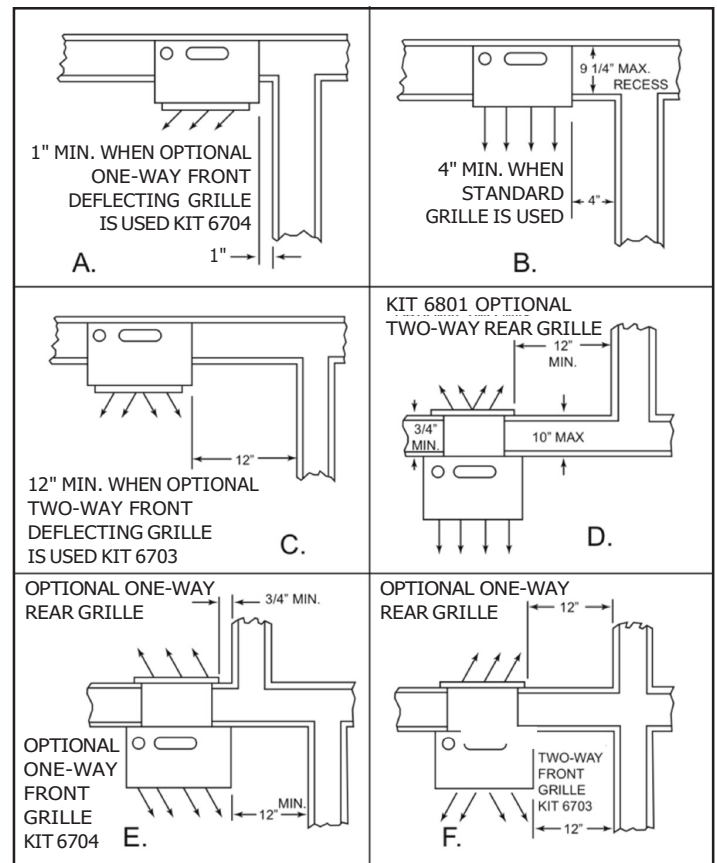

⚠ WARNING: Danger of property damage, bodily injury or loss of life. Do not install furnace in any area where oxygen is in use.

Combustion & Ventilation Air

⚠ WARNING: Danger of property damage, bodily injury or loss of life. The furnace and any other fuel-burning appliances must be provided with enough fresh air for proper combustion and ventilation of flue gases. Most homes will require that outside air be supplied into the heated area.

The high cost of energy for home heating has brought about new materials and methods used to construct or remodel most current homes. The improved construction and additional insulation has reduced the heat loss and made these homes much tighter around windows and doors so that infiltrated air is minimal. This creates a problem to supply combustion and ventilation air for gas-fired or other fuel burning appliances. Any use of appliances that pull air out of the house (clothes dryers, exhaust fans, fireplaces, etc.) increases this problem and appliances could be starving for air.

In addition, these energy measures mean that your home will retain more water vapor or a higher relative humidity.

High humidity, especially during cold weather, may be damaging to buildings because condensation forms on windows and inside walls.

The combination of a tight energy efficient home with the use of exhaust fans, fireplaces, clothes dryers, and gas appliances result in more and more air being drawn from the house until fresh air may be sucked back into the house down a furnace flue or fireplace chimney. Carbon monoxide can be the result. Carbon monoxide (CO) is a colorless, odorless gas produced when fuel is not burned completely or when the flame does not receive sufficient oxygen.

Automobiles, charcoal, wood fires and improperly vented or air-starved coal, oil and gas furnaces or other appliances can produce carbon monoxide.

BE AWARE OF THESE AIR-STARVATION SIGNALS:

1. Headaches, nausea, dizziness.
2. Excessive humidity shown by heavily frosted windows or a moist "clammy" sensation.
3. Fireplace smoke fills the room or will not draw.
4. Furnace flue backs up.

AIR REQUIREMENTS

The requirements for providing air for combustion and ventilation are listed in the National Fuel Gas Code NFPA 54/ANSI Z223.1 (in Canada: CAN/CGA B149). Most homes will require that outside air be supplied to the heated area by means of ventilation grilles or ducts connecting directly to the outside or spaces open to the outdoors such as attic or crawl space. The only exception is when the furnace area meets the requirements and definitions for an unconfined space with adequate air infiltration.

⚠ WARNING: Danger of property damage, bodily injury or loss of life. The furnace and any other fuel-burning appliances must be provided with enough fresh air for proper combustion and ventilation of flue gases. Most homes will require that outside air be supplied into the heated area.

All air openings and connecting ducts must comply with the following:

If the furnace is installed in an area with another gas appliance(s), the total input rating of all appliances must be considered when determining the free area requirements for combustion and ventilation air openings.

Ducts must have the same cross-sectional area as the free area of the openings to which they connect. The minimum dimension of rectangular air ducts must not be less than 3 inches in length or height.

LOUVERS / GRILLES AND SCREENS COVERING FREE AREA OPENINGS

If a screen is used to cover the opening(s), it must not be smaller than 1/4-inch mesh. Use the free area of a louver or grille to determine the size opening required to provide the free area specified. If the free area is not known, assume a 20% free area for wood and a 60% free area for metal louvers or grilles.

EXAMPLE 1

FURNACE LOCATED IN UNCONFINED SPACE.

An unconfined space must have a volume of a minimum 50 cubic feet per 1000 BTU/hr. of total of all appliances in area. Adjoining rooms may be included only if there are no doors between the rooms, or if special provisions are made such as ventilation grilles installed between connecting rooms.

Page 10, Figure 6 shows the minimum area in square feet based on 8 foot ceiling heights, required for different BTU/hr. input ratings.

A. If your furnace is in an open area (unconfined space) the air that leaks through the cracks around doors and windows may be enough for combustion and ventilation air. The doors should not fit tight. The cracks around windows should not be caulked or weather stripped. To determine if infiltration air is adequate, perform following checks:

1. Close all doors and windows. If you have a fireplace, start a fire and wait until flames are burning vigorously.
2. Turn on all exhausting devices, such as: kitchen and bathroom exhaust fans dryers (gas and electric)
3. Turn on all vented gas appliances, such as: heating equipment including any room heaters, water heater/stoves.
4. Wait ten (10) minutes for drafts to stabilize.
5. Check for draft hood spillage at each appliance. (Hold a lighted match 2 inches from draft opening).

See Figure 4

B. No Spillage

If the match flame pulls toward draft hood (this indicates sufficient infiltration air):

1. Return exhausting devices and appliances to the condition you found them.

C. Draft Hood Spills

If there is spillage at a draft hood (match goes out or flame wavers away from draft hood):

1. Check for plugged flue connectors and chimneys. Check and repair blockages and test again.
2. If you have a fireplace, open a window or door near the fireplace and then check for spillage.
 - a) If spillage stops, do not use the fireplace without a nearby window or door open until you can supply fresh air by a permanent duct.
3. If you have kitchen and bathroom exhaust fans, turn them off and check for spillage.
 - a) If spillage stops, do not use exhaust fans until you can supply fresh air by a permanent duct.

⚠ WARNING: Danger of property damage, bodily injury or loss of life. Draft hood spillage, with unobstructed vents, indicates that additional air must be brought into the structure from outside. Keep a window open (minimum 2 inches) near the appliance until a permanent air duct is installed.

INSTALLING YOUR FURNACE

FIGURE 4 – DRAFT HOOD SPILLAGE

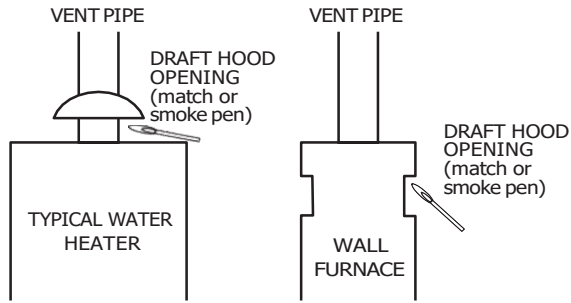

4. Spillage means air starvation and a fresh air duct or air intakes must be installed to provide air directly to the furnace or other gas appliance.
- D. If spillage exists or when the furnace is in a building of tight construction where the windows and doors are weather stripped, air for combustion and ventilation must be obtained from outdoors or space open to the outdoors.

Provide an opening(s) having a total free area of 1 square inch per 4,000 BTU/hr. for the total of all appliances. The required area is shown on **Figure 9**.

FIGURE 5 - FRESH AIR DUCT

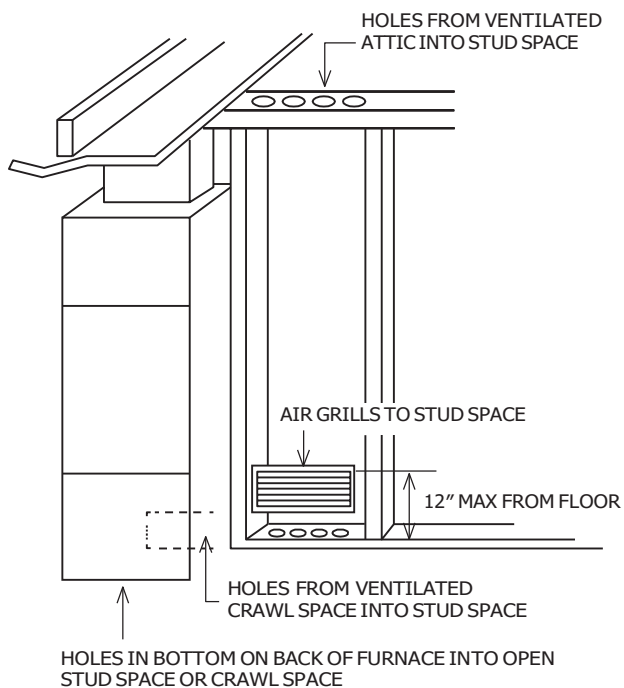

Figure 5 shows a typical duct going into ventilated crawl space or attic.

1. Duct must terminate at a point not more than 1 foot above the floor.
2. Duct size must be at least 1 inch of free area for each 4000 BTU/hr. of input of all appliances in area.

EXAMPLE 2

FURNACE LOCATED IN CONFINED SPACE

If furnace is installed in a confined space, it must be provided with free air for proper combustion and ventilation of flue gases by one of the following methods.

A. ALL AIR FROM INSIDE BUILDING:

If the confined space adjoins an unconfined space, provide two permanent openings, one within 12 inches of the top and one within 12 inches of the bottom of the room connecting directly to unconfined space. Each opening must have a free area of at least 100 square inches or 1 square inch per 1000 BTU/hr. combined input of appliances in one room if combined input exceeds 100,000 BTU/hr.

⚠ WARNING: Danger of property damage, bodily injury or loss of life. The adjoining unconfined space must have adequate air infiltration as defined in **EXAMPLE 1**.

FOR EXAMPLE: Your furnace is rated at 50,000 BTU/hr. The water heater is rated at 30,000 BTU/hr. The total is 80,000 BTU/hr. You need two grilles, each with 100 square inches of free opening. Metal grilles have about 60% free area, so you need two metal grilles each with 160 square inches of louvered area.

FIGURE 6 - MINIMUM AREA IN SQUARE FEET

4,000 BTU/hr. per square inch opening			
Round duct dia.	Rectangular square duct size	Max. BTU/hr input	*Uncontained space min. area in sq. ft. 8' ceiling height
4"	3" x 3"	30,000	188
4"	3" x 3"	35,000	219
4"	3" x 4"	40,000	250
4"	3" x 4"	45,000	281
4"	3" x 5"	50,000	312
4 ½"	3" x 5"	60,000	375

* Can be two or more rooms joined by ventilation grills.

Refer to figure as shown on **Page 11, Figure 7**, which shows grille installation. Using the previous example, the two connecting rooms plus the closet must equal at least 500 sq. feet to handle the combined input 50,000 plus 30,000.

B. ALL AIR FROM OUTDOORS:

If confined space doesn't adjoin an unconfined space then air must be provided from outdoors or spaces open to outdoors such as attic or crawl space.

Provide two permanent openings, one within 12 inches of top, one within 12 inches of bottom of room connecting directly, or by using ducts, with the outdoors or areas open to outdoors.

If opening connects directly to, or within vertical ducts, the free area of each opening must be at least 1 square inch per 4,000 BTU/hr. combined input of appliances in area.

If horizontal ducts are used, the free area of each opening must be at least 1 square inch per 2,000 BTU/hr. combined input of appliances in area.

FIGURE 7 - GRILLES CONNECTING ROOMS TO MAKE UNCONFINED SPACE

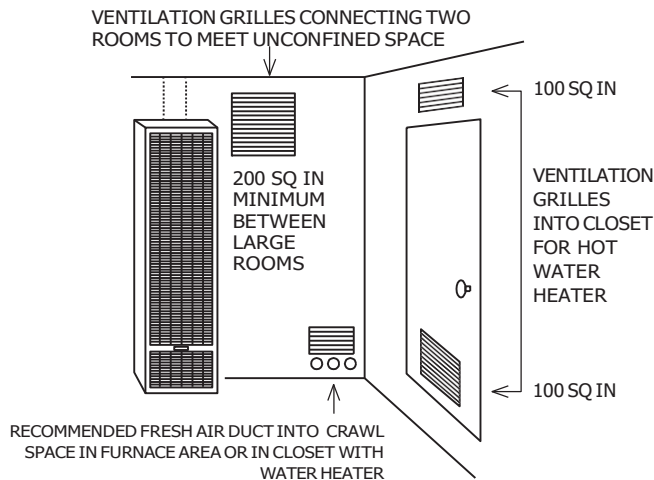

FOR EXAMPLE: Your furnace is rated at 50,000 BTUu/hr. The water heater is rated at 30,000 BTU/hr. The total is 80,000 BTU/hr. You need two grilles, each with 20 square inches of free opening, unless connected by horizontal ducts which would require each grille or opening to have a free area of 40 square inches.

FIGURE 8

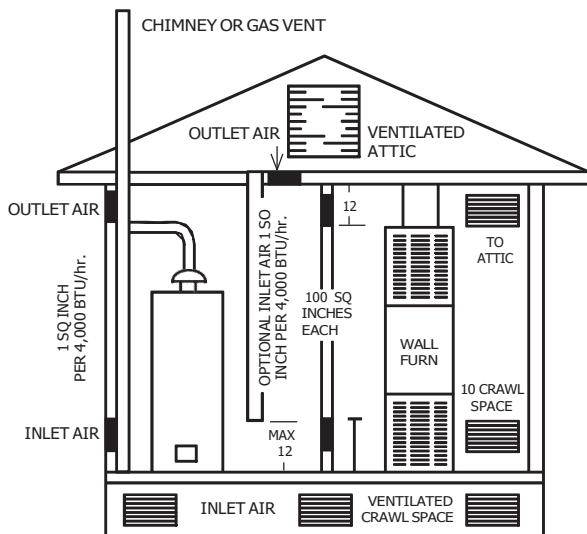

Openings for inlet or outlet air should not be made into attic area if attic is equipped with a thermostat controlled power vent.

FIGURE 9

Free Area in Square Inches.

Each opening is based on one square inch per 4,000 BTU/hr

BTU/hr input	Square inches of opening	Required number of holes sill or header plates		
		1 - 1/2"	2"	3"
30,000	7.5	7	4	2
35,000	8.75	8	5	2
40,000	10.00	9	5	3
45,000	11.25	10	6	3
50,000	12.50	11	8	3
60,000	15.00	13	8	4

Shown in square inches - each opening (furnace only)
Based on one square inch per 4,000 BTU/hr.

Recessed Wall Mount Installation

FIND THE STUDS AND CEILING JOINTS

(see **CAUTION** on page 7)

Use a stud locator or small finishing nails. Repeatedly drive and remove a nail into the wall in the area of the stud until it is located. Then find the inside edge of the stud. Leave the nail at this location.

The other stud should be about 14½-inches from the one found. Drive finishing nails on the inside of this stud. Draw wall cutout to required size as shown on **Figure 13**. If wall studs are not on 16-inch centers. See "CLOSE OFF STUD SPACE." (As shown on **Figure 12**).

CUT WALL OPENING

Provide an opening as shown on **Figure 10**. Work from the top in the attic to cut away the ceiling plate.

WARNING: BEFORE INSTALLING: To avoid electrical shock, turn off electrical circuits that pass through the wall where you are going to install the furnace.

ATTACH HEADER PLATE

MODELS: 5508231; 5508232; 6508631; 6508632

Locate header plate between wall studs at 88-½ inches from finished floor and nail into position with end flanges pointing up. Make sure header plate is level.

MODELS: 5008631; 5008632

Locate header plate between wall studs at 82-½ inches from finished floor and nail into position with end flanges pointing up.

MODELS: 3508231; 3508232; 3508631; 3508632

Locate header plate between wall studs at 74 inches from finished floor and nail into position with end flanges pointing up.

INSTALLING YOUR FURNACE

WARNING: Remove 4" x 14" fiberglass gasket from bottom of header plate and discard. This gasket is not used when the furnace is recessed in the wall.

FIGURE 10

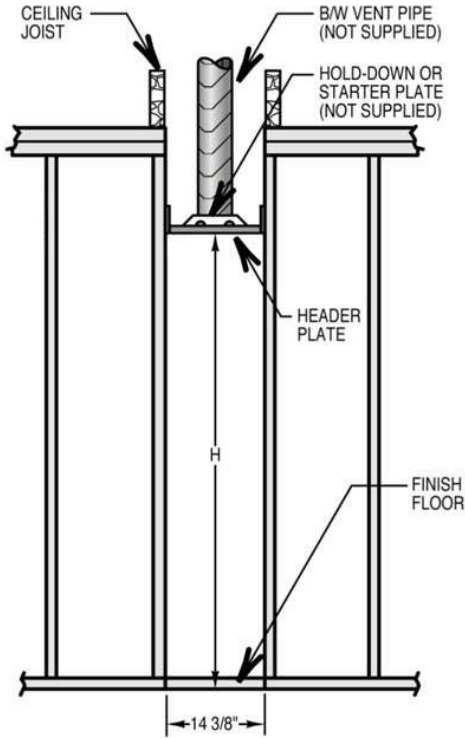

GAS SUPPLY OPENING

A hole must be drilled for the gas line supply. Decide whether the gas line will come through the floor or wall stud.

NOTE

If a pre-existing gas piping stub location is not compatible with hole or knock-out provided in furnace, you may make an alternate entry hole in the furnace back wall as shown on Figure 14.

CAUTION: Be careful not to damage any furnace components while making any alternate hole.

Locate and drill one (1) 1-1/2 inch hole at selected locations as shown on Figure 11, Figure 13 or Figure 14.

Gas line can be run at this time or done after furnace is mounted, see section GAS SUPPLY AND PIPING, page 18.

FIGURE 11

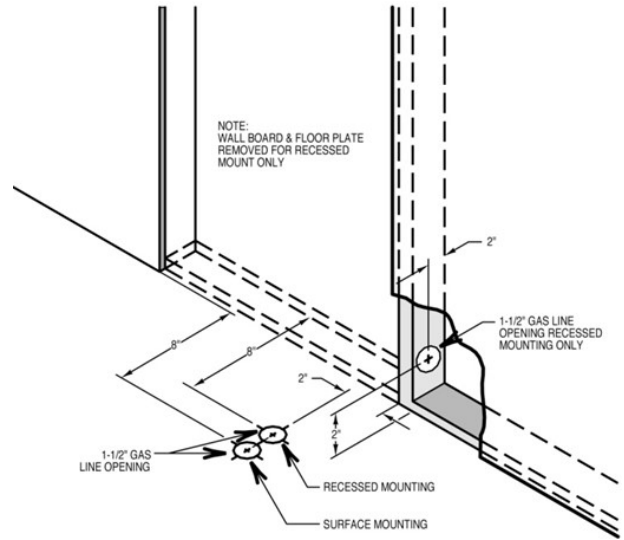

CLOSE OFF STUD SPACE (IF REQUIRED)

If studs are not on 16 inch centers, cut the hole for the furnace next to an existing stud and frame in the other side using a 2 x 4 and spacer blocks as required. As shown on Figure 12.

ELECTRICAL SUPPLY ROUGH-IN

Run the electrical supply with the ground wire and thermostat cable into stud space next to furnace location.

FIGURE 12 - CLOSED OFF STUD SPACE (IF REQUIRED)

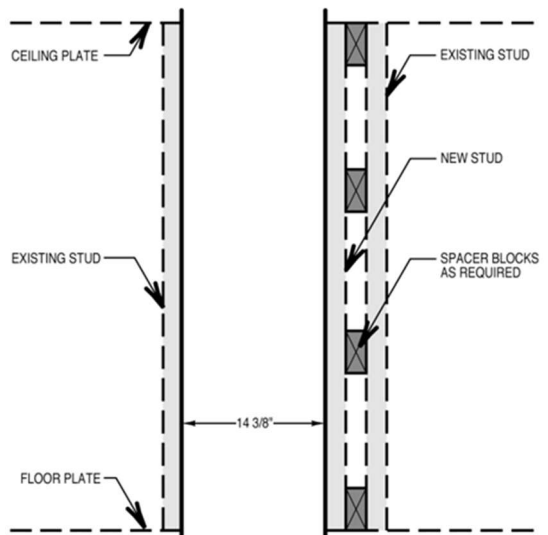

CAUTION: Do not run wire behind flanges of header plate or in any location where it might be damaged. Avoid splicing thermostat wire unless the spliced wires are properly cleaned, soldered and taped.

FIGURE 13 - KNOCKOUT DIMENSIONS

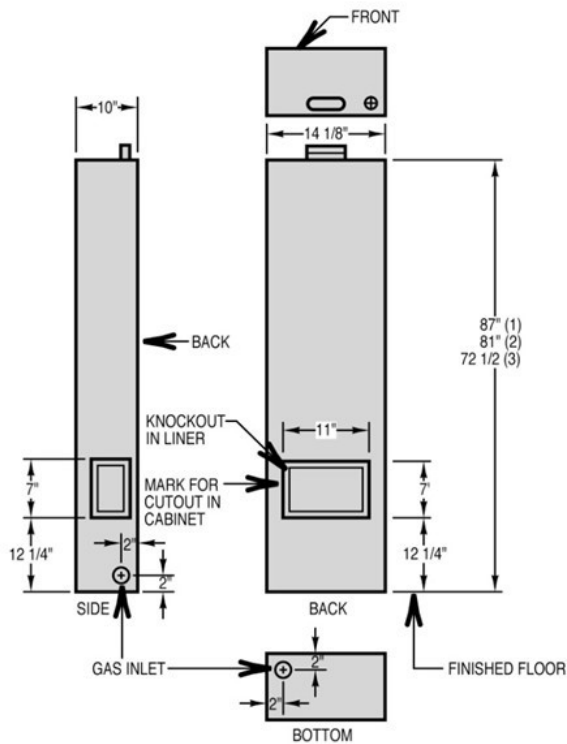

- (1) MODELS: 5508331; 5508332;
6508731; 6508732
- (2) MODELS: 5008731; 5008732;
- (3) MODELS: 3508331; 3508332;
3508731; 3508732

Surface Mount Installation

FIND THE STUDS AND CEILING JOISTS (See CAUTION on page 7)

Find two studs at spot where furnace is to be placed. Use a stud indicator or small finishing nails. Repeatedly drive and remove a nail into the wall in the area of the stud until you find it. Then find one side. Leave the nail there. Drive another nail just on the other side of the same stud.

Inside edge of the other stud should be about 14 1/2 inches from the one found. Drive finishing nail on inside edge of this stud.

Using the nails as a guide, draw a line up both sides to the ceiling to locate hole cut out for vent pipe and electrical connections.

CUT CEILING OPENING

Mark off and cut 3 1/2 x 12 inch rectangular hole in ceiling, centered between wall studs. The back edge of the opening should be about 1/8 inch from the wall. As shown on **Page 14, Figure 16**.

ELECTRICAL SUPPLY ROUGH-IN

The electrical supply openings must be made in the wall or floor below furnace to match holes in furnace bottom.

See Figure 13.

If desired, the power supply and thermostat cable can come into the wall stud space from a basement, crawl space or an adjoining stud space.

At selected location, drill a 1 inch hole for 115V power supply and a 1/2 inch hole for the thermostat cable.

Run wiring through the holes to the furnace leaving enough excess wire to make electrical connections after mounting furnace.

CAUTION: To avoid damage to wiring, be sure to route wire away from path of furnace vent.

GAS SUPPLY OPENING

A hole may need to be drilled for the gas line supply. Decide whether the gas line will come through the floor or wall.

NOTE

If you decide to route gas line through right side of furnace, simply remove the knock-out provided in furnace side.

NOTES

If a pre-existing gas piping stub location is not compatible with hole or knock-out provided in furnace, you may make an alternate entry hole in furnace back wall per **Figure 14**.

CAUTION: Be careful not to damage any furnace components while making any alternate hole.

Locate and drill one (1) 1-1/2 inch hole at selected location as shown on **Figure 11, Figure 13, or Figure 14**.

Gas line can be run at this time or done after the furnace is mounted, see section **CONNECTING GAS LINE**.

FIGURE 14 - ALTERNATE GAS SUPPLY OPENING

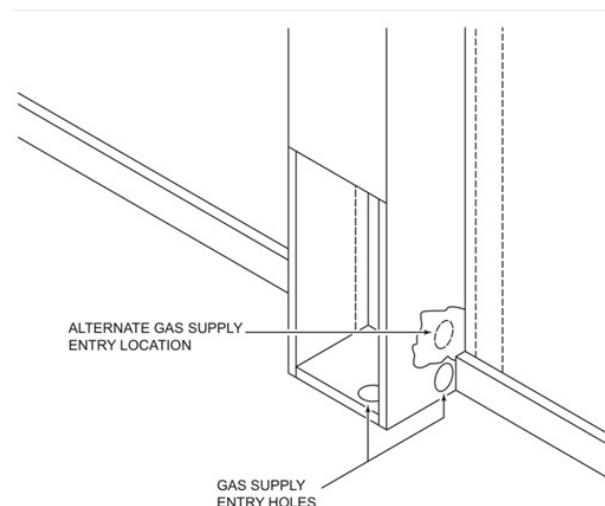

INSTALLING YOUR FURNACE

General Vent Installation

The vent installation must comply with all local codes and ordinances. If in doubt, consult your local codes or inspector. The furnace vent must be directed to the outdoors so that harmful combustion gases will not collect inside the building.

This furnace must not be connected to a chimney flue serving a separate solid-fuel burning appliance.

Use U.L. listed B/W Vent Kit 9901. You must provide other items, not contained in the kit, necessary to complete your specific venting situation through the roof. Refer to typical venting system as shown on **Figure 18**.

Type B/W gas vent shall extend from the header plate of the vented wall furnace to a point above the highest ceiling plate within a stud space through which the vent passes, without any offsets or crossovers therein. After a type B/W gas vent passes through the highest ceiling plate within a stud space above the furnace which it serves, the vent system may be completed with a type B vent, of the same manufacturer, and offsets or break over, shall not be greater than 45 degrees from vertical. Maximum of two.

NOTE

The B/W vent must extend through the ceiling and roof terminating at least 12 feet above the finished floor on which the furnace rests.

First vent pipe offset (if required) is recommended not to be any closer than 2' 0" from header plate.

ATTACH HEADER & HOLD-DOWN PLATE (SURFACE MOUNT)

Remove the fiberglass flue collar from the furnace flue extension. This gasket is not used when the furnace is surface mounted.

Make sure that the 4 x 4 inch gasket is in position on the header plate.

Slide header plate over the furnace flue extension with the junction box entering the opening in top of furnace.

Refer to **Figure 15**.

FIGURE 15

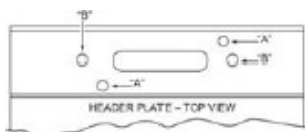

Fasten to matching holes in the furnace top through holes "A" in the header plate, using two (2) #8 x 3/8 inch screws provided.

Fasten the hold-down plate or starter plate to the top of the header plate using holes "B" in the header plate.

ALL MODELS

ATTACH HOLD-DOWN PLATE (RECESSED MOUNT)

NOTE

Header plate should already be attached to wall studs. See ATTACH HEADER PLATE, on **Page 11 and 12**.

Fasten hold-down plate to top of header plate using two (2) screws provided.

FIGURE 16

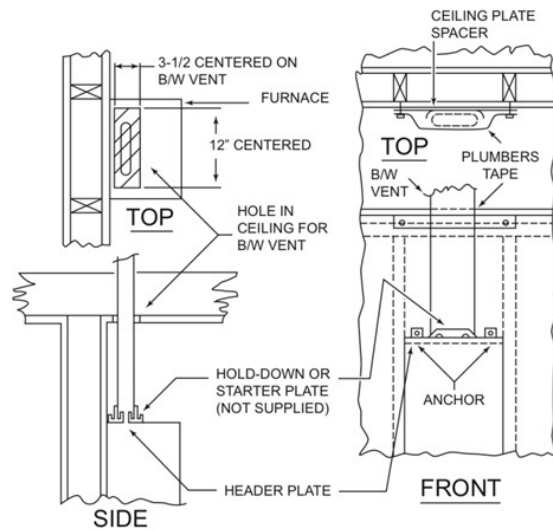

INSTALL CEILING PLATE SPACERS (SURFACE MOUNT)

Refer to **Figure 16**.

Only one (1) plate spacer is required for surface mounting within a single story dwelling.

Cut 2 inches off each end of plate spacer.

Drill two (2) 3/16 inch holes in each end of plate spacer as shown in **Figure 16**.

Fasten plate spacer to wall by nailing through one (1) drilled hole in each end, into the wall board and ceiling plate.

INSTALL CEILING PLATE SPACER (RECESSED MOUNT)

Refer to **Figure 17**.

Two ceiling plate spacers are in the B/W vent kit 9901. They must be fastened along each long edge of the ceiling hole to hold the oval vent pipe in the center of the hole.

Nail the ceiling plate spacers either across or in between the cut out section of ceiling plate. If nailed between, ends must be bent at 90 degrees.

FIGURE 17 - CEILING PLATE SPACERS

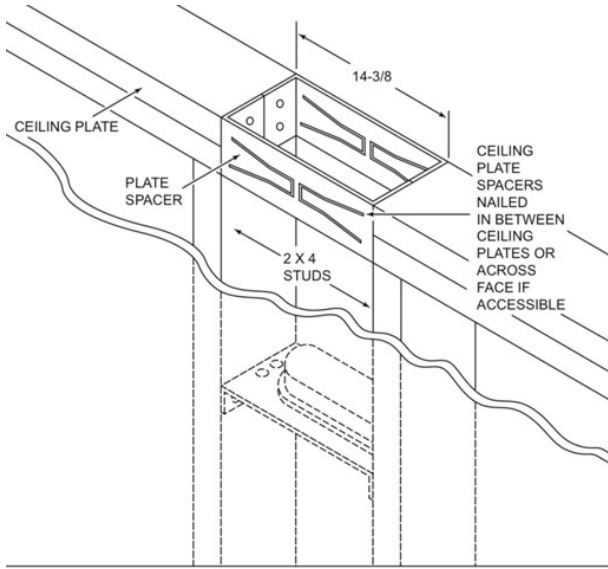

*Recessed mount

FIGURE 18

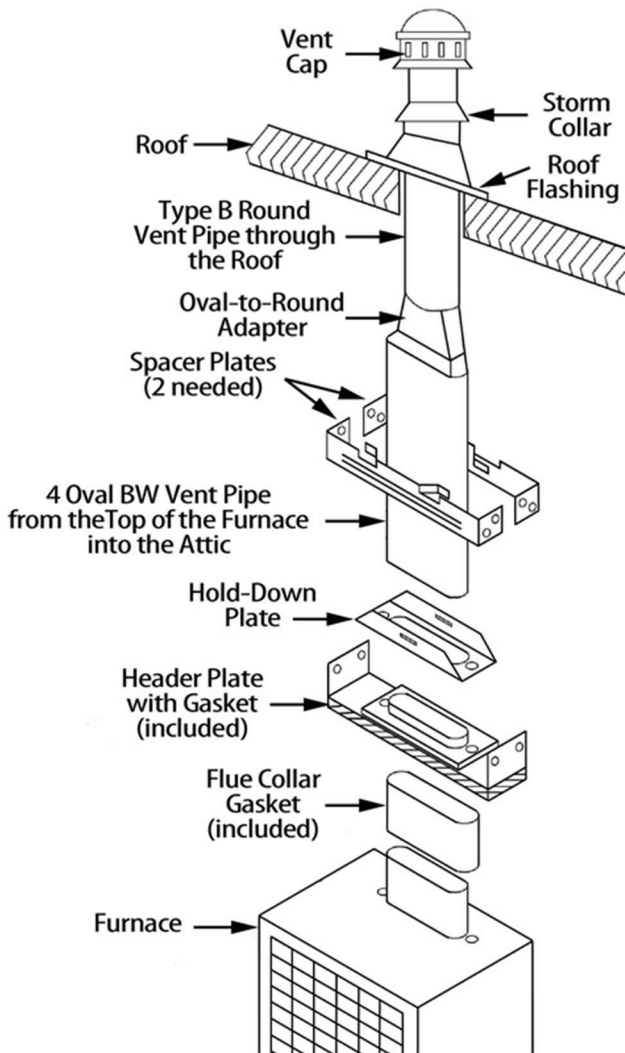

INSTALL SURFACE VENT (SURFACE MOUNT)

NOTE

For surface mounting, it will be helpful to complete the gas piping supply to the furnace before installing the vent pipe. See section GAS SUPPLY & PIPING, page 17.

Carefully move the furnace into position under the ceiling cutout.

Insert first lengths of oval, double wall vent pipe up through the ceiling cutout. Lower vent pipe to the hold-down plate. Push the vent pipe into the hold-down plate until it is completely seated. (Hold-down cleats will engage the groove in the vent pipe.)

FIGURE 18 - ALTERNATIVE VENTING

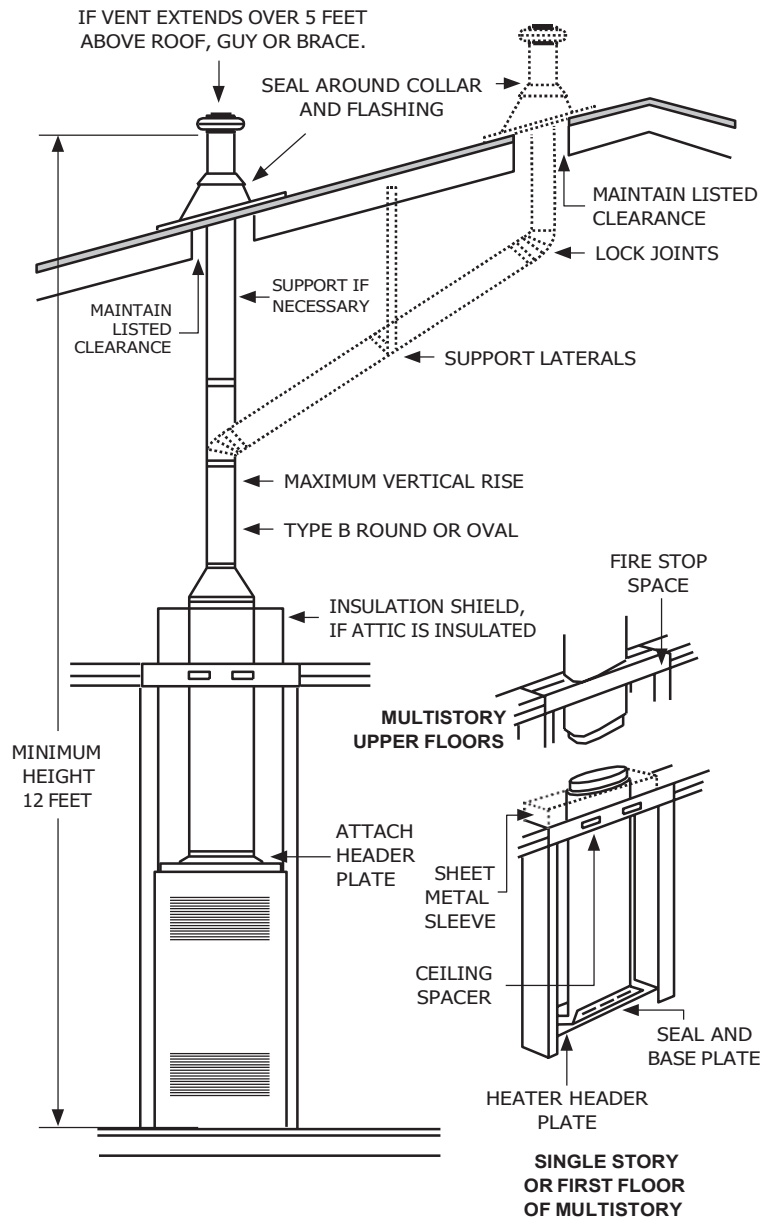

INSTALLING YOUR FURNACE

Secure hold-down plate to vent pipe using two (2) screws.

Using plumbers tape to secure vent to the plate spacer, nail through one (1) hole in each end of plate spacer, into the wall and ceiling plate.

INSTALL FURNACE VENT (RECESSED MOUNT)

Lower first lengths of oval, double wall vent pipe through the plate spacers to the hold-down plate.

Push the vent pipe into the hold-down plate until it is completely seated. (Hold-down cleat will engage the groove in the vent pipe.)

Secure hold-down plate to vent pipe using two (2) screws.

COMPLETE THE VENTING

Refer to **Figure 18**.

Install oval to round adapter. Complete the piping extending it through the roof. Use 4" round, double wall (Type B) vent pipe, roof flashing, storm collar, and vent top as shown. The vent cap must be at least 2 feet higher than any point that is within 10 feet horizontally of the vent cap. There must be at least 1 inch clearance between the vent pipe and any combustible material.

IMPORTANT

Area above header within the stud space **MUST** be kept clear of any attic insulation to allow the free circulation of air around oval vent piping.

Mounting Your Furnace

To obtain adequate clearance for fastening furnace or to install gas supply fittings, it may be necessary to remove the burner and control assembly as follows:

Remove burner compartment door by pulling door top out and up.

Locate the air discharge shield. It is secured across the top of the burner control compartment. Remove two (2) screws and shield and set aside. Refer to the illustration on **Page 29 #26 or 34 #19**.

DISCONNECT WIRING

MODELS: 3508231; 3508232; 5508231; 5508232

Remove the screws holding the ignition control unit and cover to the furnace casing.

Disconnect wires to free control module from its mounting location. Mark or tag each wire removed for its exact reconnection. Refer to **Figure 19**.

ALL OTHER MODELS

Disconnect two (2) 24 volt wires from the gas valve. Disconnect two (2) wire connectors from junction block midway on the thermocouple

REMOVE BURNER AND CONTROLS

MODELS: 3508231; 3508232; 3508631; 3508632

Locate the burner and screws that secure it. Remove the two (2) screws (one from each end). Lift one end of the burner at a time until free. Remove burner and controls from the compartment.

Remove the screws holding the ignition control unit and cover to the furnace casing.

FIGURE 19

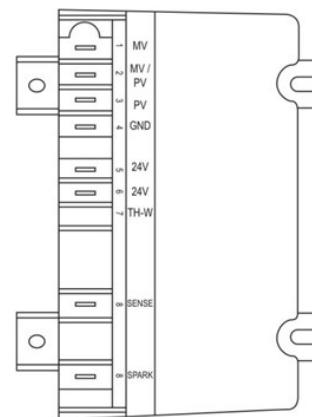

**WILLIAMS IGNITION CONTROL
PART NUMBER P321910**

ALL OTHER MODELS

Locate the burner and hex nuts that secure it. Remove the two (2) hex nuts (one from each end). Flip up the wire hinges. Lift one end of burner at a time until free. Remove burner and controls from the compartment.

POSITION FURNACE (RECESSED MOUNT ONLY)

NOTE

If your furnace is surface mounted, your mounting was started during VENT INSTALLATION, **page 14**. To complete furnace mounting, go on to FASTEN FURNACE BOTTOM on this page.

ALL MODELS

Make sure that the flue collar gasket, as shown on **Figure 18**, is in place over the flue extension. Check to see if header plate gaskets are in place.

Hold the furnace at a slight angle (top closer to the wall than bottom) with the flue extension centered under the oval hole in the header plate.

NOTE

Electrical wiring should already be routed to the header plate. If not, see sections on ELECTRICAL SUPPLY ROUGH-IN, **page 12**.

Place three (3) square gaskets over the junction box. See **Figure 18**.

ALL MODELS (RECESSED MOUNT)

Lift furnace up so that the flue extension enters the oval hole in the header plate. Straighten the furnace by pushing furnace bottom into the stud space.

IMPORTANT

AFTER FURNACE HAS BEEN PLACED IN POSITION, MAKE SURE THE GASKETS ARE PRESSING AGAINST THE FURNACE TOP TO ELIMINATE AIR LEAKS.

FASTEN FURNACE BOTTOM (SURFACE AND RECESSED MOUNT)

NOTE

Fasteners are not furnished because of different requirements of various types of wall construction.

FIGURE 20 - FURNACE MOUNTING

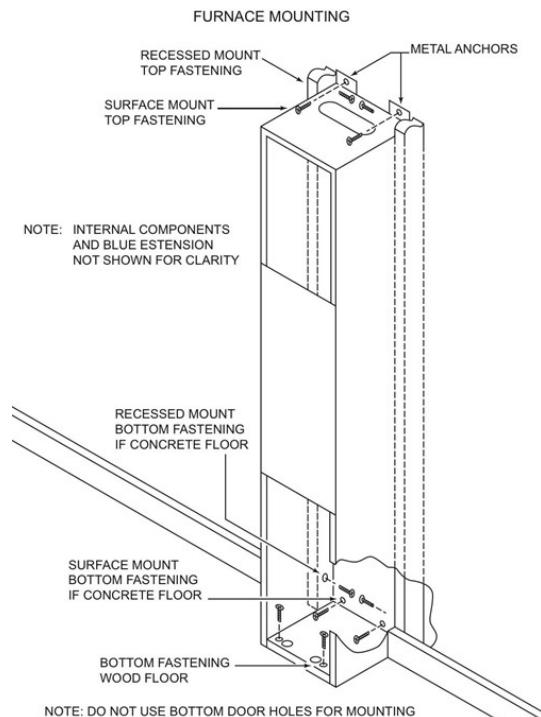

Fasten furnace to floor through holes provided in furnace bottom. If you have concrete flooring, use an alternate fastening method. See **Figure 20**

If burner and control assembly were removed, replace them by reversing "DISCONNECT WIRING" and "REMOVE BURNER AND CONTROLS" sections on **page 18**.

IMPORTANT

To prevent damage to wiring, make sure not to pinch the wires between furnace components. Keep them routed away from the burner.

Re-secure the air discharge shield across the top of the burner and controls compartment. Small leg of "L" shape must be positioned toward floor, pointing away from front of furnace. Refer to the illustration on **Page 34 or 35**.

FASTEN FURNACE TOP (SURFACE MOUNTING)

Fasten furnace top to wall using two (2) metal anchors (packed in plastic bag with thermostat) by placing them over the back flange of furnace top and screwing to wall. Refer to **Figure 20**.

FASTEN FURNACE TOP (RECESSED MOUNTING)

Fasten furnace top by drilling two (2) holes through the side flanges of furnace top and securing with two (2) screws or nails into the wall studs. Refer to **Figure 20**.

CAUTION: Be careful not to damage furnace components or wiring when drilling holes.

Gas Supply and Piping

Gas control valve, within the furnace, is shipped with a seal over the gas inlet tapping. Do not remove seal until ready to connect piping.

WARNING: Danger of property damage, bodily injury or death. Make sure the furnace is equipped to operate on the type of gas available. Models designated as natural gas are to be used with natural gas only. Furnace designated for use with liquefied petroleum propane gas rate orifices sized for commercially pure propane gas. They cannot be used with butane or a mixture of butane and propane.

GAS SUPPLY

For natural gas, the minimum inlet gas supply pressure for the purpose of input adjustment is 5" water column. The Maximum inlet gas supply pressure is 7" water column.

For propane gas, the minimum inlet gas supply pressure for the purpose of input adjustment is 11" water column. The maximum inlet gas supply pressure is 13" water column.

Gas pressure and input to the burners must not exceed the rated input and pressure shown on the rating plate.

INSTALLING YOUR FURNACE

On natural gas the manifold pressure should be 4 inches water column. The manifold pressure should be 10.5 inches water column for propane gas. **See page 19** for operation above 2,000 feet altitude. Orifice change may be required to suit gas supplied. Check with your local gas supplier.

ORIFICE SIZES

Furnace Technical Information, **page 25**, shows the correct orifice sizes for the different input ratings when using natural or propane gas.

GAS PIPING

The gas supply line must be of adequate size to handle the BTU/hr. requirements and length of the run for the unit being installed.

Determine the minimum pipe size from **Figure 23**, basing the length of the run from the gas meter or source to the unit.

FIGURE 21 - LEFT SIDE GAS INLET

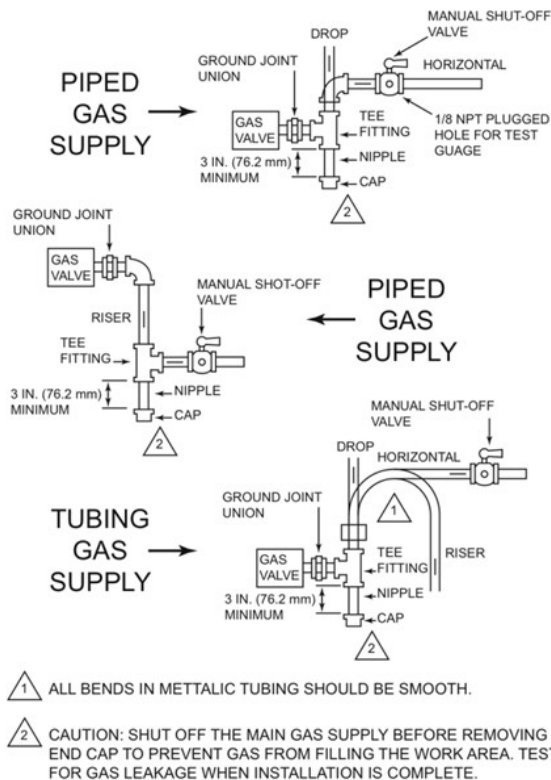

*Left side gas inlet shown. Models vary. Check to be sure.

FIGURE 22 – PROPER PIPING PRACTICE

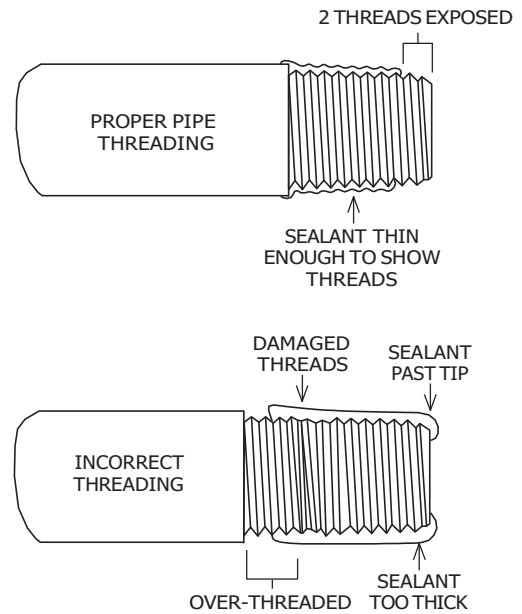

All piping must comply with local codes and ordinances or with the National Fuel Gas Code (ANSI Z223.1), whichever applies. In Canada: Follow CAN 1(B149 Installation Code).

Refer to **Figure 21**, for the general layout at the unit. It shows the basic fittings needed.

The following rules apply:

1. Use new, properly reamed pipe free from metal chips and debris such as steel or black iron pipe. Use fittings approved by local codes.
2. Do not thread pipe too far. Valve distortion or mal function may result from excess pipe within control. Apply moderate amount of good quality dope to pipe only, leaving 2 end threads bare. If propane gas installation, use compound resistant to action of liquefied petroleum gases.
3. Use ground joint unions.
4. Install a drip leg to trap dirt and moisture before it can enter the gas valve. Drip leg must be a minimum of 3 inches long.
5. Install a manual shut-off valve.
6. Provide a 1/8" NPT test gauge connection immediately before the gas supply connection to the furnace.

GAS CONNECTION

If installation is for propane gas, have propane gas installer use two-stage regulation and make all connections from storage tank to furnace. Use two pipe wrenches when making the connection to the valve to prevent turning or damage to gas valve.

Connections between the manual shutoff valve and burner control assembly can be made with an A.G.A./ C.G.A. design certified flexible connector if allowed by local codes. Drip leg and ground joint unions are still required.

Tighten all joints securely.

CHECKING THE GAS PIPING

Test all piping for leaks. When checking gas piping to the furnace with gas pressure less than 1/2 PSI, shut off manual gas valve to the furnace. If gas piping is to be checked with the pressure at or above 1/2 PSI, the furnace and manual shut off valve must be disconnected during testing. (SEE WARNING.) Apply soap solution to each joint. Bubbles forming indicate a leak. Correct even the slightest leak at once.

⚠ WARNING: Danger of property damage, bodily injury or loss of life. Never use a match or open flame to test for leaks. Never exceed specified pressures for testing. High pressures may damage the gas valve and cause over-firing which may result in heat exchanger failure. liquid petroleum (propane gas) is heavier than air and it will settle in any low area, including open depressions and it will remain there unless area is ventilated. Never attempt startup of unit before thoroughly ventilating area.

FIGURE 23 - GAS PIPE SIZES

PIPE CAPACITY - BTU/hr. WITH FITTINGS

NATURAL GAS PIPE CAPACITY BTU/hr.			
LENGTH OF PIPE FEET	PIPE SIZE (INCLUDES FITTINGS)		
	1/2"	3/4"	1"
20	92,000	190,000	350,000
40	63,000	130,000	245,000
60	50,000	105,000	195,000
PROPANE PIPE CAPACITY BTU/hr.			
LENGTH OF PIPE FEET	PIPE SIZE (INCLUDES FITTINGS)		
	1/2"	3/4"	1"
20	189,000	393,000	732,000
40	129,000	267,000	504,000
60	103,000	217,000	409,000

Electrical Wiring

The appliance, when installed, must be electrically grounded in accordance with local codes, or in the absence of local codes, with the National Electrical Code (ANSI/NFPA 70) or Canadian Electrical Code (CSA C22.1), if an external electrical source is utilized. This appliance is equipped with a three-prong (grounding) plug for your protection against shock hazard and should be plugged directly into a properly grounded three-prong receptacle. Do not cut or remove the grounding prong from this plug.

ELECTRICAL SUPPLY

Remove three-prong (grounding) service cord from the envelope parts package to install in the furnace. Remove 7/8" diameter (22mm) knockout at the left or right bottom side panel to route the three-prong service cord to an electrical outlet.

1. Insert the nylon cap attached to the end of the three-prong service cord thru the 7/8" diameter (22mm) knockout into the burner control assembly area and insert it into the nylon plug attached to the outer casing bottom. If desired, you may route the thermostat wire alongside of the service cord and thru the same opening or choose another entry into the burner control assembly area.
2. Attach 7/8" diameter (22mm) strain relief around the three-prong (grounding) service cord and the thermostat wire (if thermostat wire is routed thru knock-out. Insert the 7/8" (22mm) strain relief into the 7/8" (22mm) hole in the side panel of furnace.

⚠ WARNING: Do not insert the three-prong (grounding) service cord inside the burner control assembly area more than 10 inches (245mm). This could cause damage to the electrical cord resulting in electrical shock hazard and/or fire.

LOW VOLTAGE CONNECTIONS

CAUTION: The Heat Anticipator will burnout if 24 volts are applied directly to thermostat by shorting out the gas valve or primary control during testing or by incorrect wiring.

WALL THERMOSTAT WIRING

Run thermostat wire to the furnace. Connect thermostat to two wires marked "Thermostat" near the gas valve of the furnace, using two wire nuts provided. See Wiring Diagrams on **pages 27 or 28.**

Replace fan to original position on motor shaft, tightening securely. Replace fan shroud, making sure it is centered vertically on the fan.

Tighten screws securely.

Replace top front panel and secure with thumbscrew.

COMPLETE WIRING DIAGRAMS ON PAGES 27 AND 28.

Thermostat Installation

(Sold Separately)

1. Use Williams thermostat P322016 or any millivolt thermostat.
2. If an old thermostat is being replaced and is in a satisfactory location and the wiring appears to be in good condition, use existing wiring. If in doubt, use new wire.
3. If a new location is chosen or if this is a new installation, thermostat cable must first be run to the location selected. All wiring must agree with local codes and ordinances. These instructions cover bringing the wire down from the attic but it can be run from a basement or crawl space using similar methods. Refer to Figure 24.
4. Before drilling a hole in the wall at selected location, drive a small finishing nail through the ceiling in the corner of the wall and ceiling above the thermostat location. Pull the nail out and push a small stiff wire through the hole so it can be found in the attic. Drill a 1/2 inch hole through the ceiling wall plate.
5. Probe for obstructions in the partition. Then drill a 1/2 inch hole through wall at the selected location for thermostat.

FIGURE 24 - ROUTE THERMOSTAT CABLE

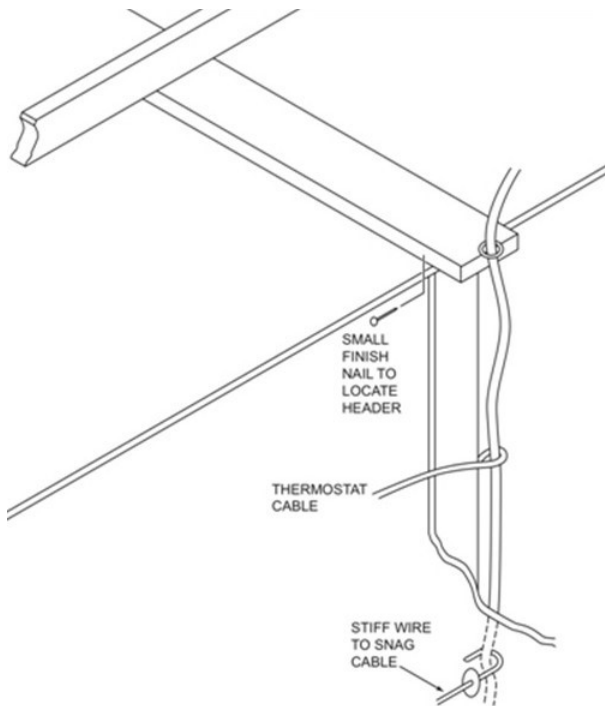

NOTE: Use heavier wire size if more than 20 ft. of wire is required

6. From the attic, feed the thermostat cable or a stiff wire through wall until even with thermostat location.
7. Snag thermostat cable through hole and pull cable through hole in wall so that 6 inches of cable protrudes.
8. Route cable to wall furnace.

MOUNTING THE THERMOSTAT

1. To remove thermostat cover, squeeze both sides and lift. Carefully remove and discard the packing tab protecting the switch contacts **See. Figure 25.**
2. Connect the thermostat wires to the terminal screws on the thermostat base.
3. Push any excess wire back through hole in wall and plug hole with insulation to prevent drafts from affecting thermostat operation.
4. Being sure to level the thermostat for best appearance, fasten the thermostat base to the wall through mounting holes with screws provided.
5. Replace the thermostat cover.

FIGURE 25 - THERMOSTAT

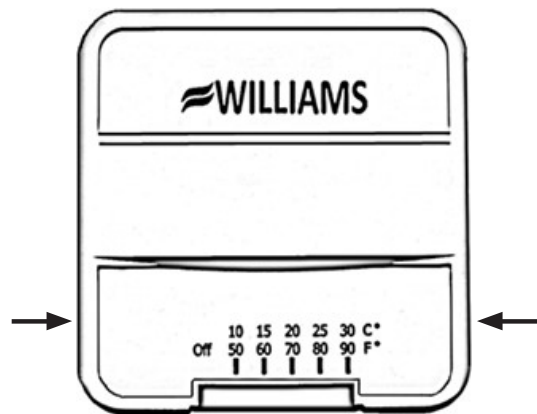

SQUEEZE FIRLY BOTH SIDES AND LIFT TO REMOVE COVER

START-UP PROCEDURE

Start the furnace using the procedures in section OPERATING YOUR FURNACE.

⚠ WARNING: Danger of bodily injury or death. Liquefied petroleum propane gas is heavier than air and it will settle in any low area, including open depressions and it will remain there unless the area is ventilated. Never attempt start-up of unit before thoroughly ventilating area.

Check the furnace operation as outlined in the following instructions. If any sparking, odors or unusual noises are encountered, shut off electric power immediately. Recheck for wiring errors or obstructions in or near fan motor.

⚠ WARNING: Natural gas heating value (BTU per cubic foot) can vary significantly. Therefore, it is the installer's responsibility to see that BTU/hr. input to the furnace is adjusted properly. Failure to do so could cause combustion chamber failure, asphyxiation, fire or explosion resulting in damage, bodily injury or death. Refer to the National Fuel Gas Code (NFPA 54) to be sure the furnace is burning fuel at the proper rate.

Under firing could cause inadequate heat, excessive condensation or ignition problems. Over firing could cause sooting flame impingement or overheating of the heat exchanger.

Before starting natural gas input check, obtain heating value of gas (BTU per cubic foot) at standard conditions from your local supplier. This factor is used in "Check the Gas Input" section and procedure.

CHECK GAS INPUT AND PRESSURES

For furnaces located at elevations between sea level and 2,000 feet, the measured input must not be greater than the input shown on the rating plate of the furnace. For elevations above 2,000 feet, the measured input must not exceed the input on the rating plate reduced by 4 percent for each 1,000 feet that the furnace is above sea level.

Gas supply pressure and manifold pressure with the burners operating must also be as specified on the rating plate.

TYPE OF GAS	MANIFOLD PRESSURE, IN. W.C.
NATURAL	4.0
PROPANE	10.0

Rated input will be obtained on a heating value of 2,500 BTU/hr. for propane at 10 inches manifold pressure with factory-sized orifices. If propane gas having a different heating value is supplied, orifices must be changed by a qualified service technician before the furnace is operated.

CHECK THE MANIFOLD GAS PRESSURE

A tapped opening is provided in the gas valve to facilitate measuring the manifold gas pressure. A "U Tube" manometer having a scale range from 0 to 12 inches of water should be used for this measurement. The manifold pressure must be measured with the burner and pilot operating. Any major changes in flow must be made by changing the size of the burner orifice.

Check with your local gas supplier for proper orifice sizing.

CHECK THE GAS INPUT (NATURAL GAS ONLY)

To measure the input, using the gas meter, proceed as follows:

1. Turn off gas supply to all other appliances except the furnace.
2. With the furnace operating, time the smallest dial on the meter for one complete revolution. If this is a 2-cubic foot dial, divide the seconds by 2. If it is a 1-cubic foot dial, use the time in seconds as is. This gives the seconds per cubic foot of gas being delivered to the furnace.
3. Assuming natural gas with a heating value of 1,000 BTU per cubic foot and 34-seconds per cubic foot used as determined by step (2), then:

$$\text{Seconds per hour} = 3,600$$

$$\text{Input} = 1,000 \times 3,600 / 34 = 106,000 \text{ BTU/hr.}$$

This measured input must not be greater than the input indicated on the nameplate of the furnace.

4. Relight all other appliances turned off in Step 1 above. Be sure all pilots are operating.

ADJUST PILOT BURNER (STANDING PILOT MODELS ONLY)

PiIot fIame should surround 3/8 inch to 1/2 inch of the thermocouple tip. To adjust, remove pilot adjustment screw on gas valve. Turn screw counterclockwise to increase flame, clockwise to decrease. Replace cap.

CHECK THERMOSTAT

Check thermostat operation. When set above room temperature shown on the thermostat, the main burner should light. Make certain the thermostat turns off the furnace when the room temperature reaches the selected setting and starts the furnace when room temperature falls a few degrees

FIGURE 26 - THERMOSTAT

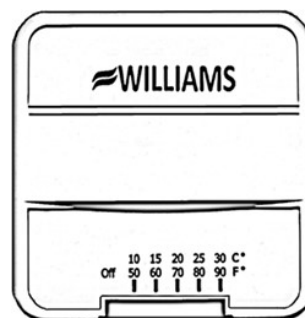

INDICATOR LOWEST SETTING

OPERATING YOUR FURNACE

STANDING PILOT MODELS

3508631 / 3508632 / 5008631 / 5008632 / 6508631 / 6508632

NOTE

For models equipped with WILLIAMS gas valve P323209 or P322042 refer to this **page 22** for "SAFETY & LIGHTING INSTRUCTION" and "TURN GAS OFF TO APPLIANCE."

On new installations, the gas lines will be filled with air and it may take several minutes to establish the pilot flame.

Keep all access doors and panels in place except for inspection and maintenance.

⚠ WARNING: The surface of the furnace is hot during operation. Keep children, clothing, furniture, and flammable material away from it. Do not store or use gasoline or other flammable liquids or vapors near the furnace.

Safety Controls

These furnace are protected against unsafe operation by five automatic safety controls: (1) A safety pilot acts to shut OFF the gas valve in case of pilot failure; (2) A redundant gas valve; (3) A limit switch shuts down the main burner to prevent overheating the furnace cabinet; (4) A vent safety shutoff device shuts down the main burner to protect against improper venting of combustion products. These limit switches will reset when furnace cools; and (5) A thermal overload protects the motor against burnout caused by current surges or if anything should block the flow of air through the furnace. This switch will reset itself when the motor cools down and it cannot be adjusted.

⚠ WARNING: Danger of ignition flash and eye injury or blindness. Protect your eyes. Never attempt to light pilot with gas control valve knob in "on" position. Flashback could occur.

NOTE

MODELS 3508631 / 3508632 are equipped with a single speed fan.

TWO-SPEED FAN OPERATION

MODELS: 5008631 / 5008632 / 6508631 / 6508632

For models equipped with WILLIAMS gas valve P323209 or P322042: Blower will first operate at low speed then shift to high speed as the furnace heats up.

IMPORTANT

KEEP BURNER AND CONTROL COMPARTMENT CLEAN.

⚠ WARNING: Danger of property damage. Bodily injury or death. If the furnace overheats or fails to shut off, close manual gas valve for the furnace before turning off the electric power.

ELECTRONIC IGNITION MODELS*

3508231 / 3508232 / 5508231 / 5508232

NOTE

For models equipped with WILLIAMS gas valve P323209 or P322042 refer to this **page and page 23** for "SAFETY & LIGHTING INSTRUCTION" and "TURN GAS OFF TO APPLIANCE."

THE FURNACE WORKS LIKE THIS:

1. Thermostat turns on the control module.
2. Automatic relight system (in module) opens gas valve and electronically ignites pilot. After pilot flame has been established and proven by the control module, the main valve circuit opens and pilot lights main burners.

Heat builds up in the furnace and starts the fan. The heated air comes out the front bottom louvered panel at floor level. When the thermostat setting is reached, it shuts off the main burner. The fan runs until the heat is removed from furnace, then it turns off.

IMPORTANT

KEEP BURNER AND CONTROL COMPARTMENT CLEAN.

SAFETY LIMIT CONTROL

These furnaces are protected against unsafe operation by three automatic safety controls: (1) The electronic ignition system; (2) A limit switch shuts down the main burner to prevent overheating the furnace cabinet; this limit switch will reset when furnace cools; (3) A thermal overload protects the motor against burnout caused by current surges or if anything should block the flow of air through the furnace, the switch will turn the main burner off. When motor cools down, this switch will reset itself. This switch cannot be adjusted.

⚠ WARNING: Danger of ignition flash and eye injury or blindness. Protect your eyes. Never attempt to light pilot with gas control valve knob in "on" position. Flashback could occur.

NOTE

MODELS 3508231 / 3508232 are equipped with a single speed fan.

TWO-SPEED FAN OPERATION MODELS: 5508231 / 5508232

Blower will first operate at low speed then shift to high speed as the furnace heats up.

OPERATING YOUR FURNACE

⚠ WARNING: The surface of the furnace is hot during operation. Keep children, clothing, furniture, and flammable material away from it.

On new installations the gas lines will be filled with air and it may take several minutes to establish the pilot flame. Keep all access doors and panels in place except for inspection and maintenance.

⚠ WARNING: Danger of property damage, bodily injury or death. If the furnace overheats or fails to shut off, close manual gas valve for the furnace before turning off electric power.

⚠ WARNING: Read owner's manual before using/installing. Be sure CHAINED LIGHTING INSTRUCTION TAG hangs at the lowest position in the furnace under/below the heat shield.

For your SAFETY, read before LIGHTING

⚠ WARNING: If you do not follow these instructions exactly, a fire or explosion may result causing property damage, personal injury or loss of life.

- This appliance has a pilot which must be lighted by hand. When lighting the pilot, follow these Instructions exactly.
- BEFORE LIGHTING** smell around the appliance area for gas. Be sure to smell next to the floor because some gas is heavier than air and will settle on the floor.

WHAT TO DO IF YOU SMELL GAS

- Do not try to light any appliance or strike a match.
- Do not touch any electric switch; do not use any phone in your building.
- Immediately call your gas supplier from a neighbor's phone. Follow the gas supplier's instructions.

If you cannot reach your gas supplier, call the fire department.

- Use only your hand to push in or turn the gas control knob. Never use tools. If the knob will not push in or turn by hand, don't try to repair it, call a qualified service technician. Force or attempted repair may result in a fire or explosion.
- Do not use this appliance if any part has been under water. Immediately call a qualified service technician to inspect the appliance and to replace any part of the control system and any gas control which has been under water.

IMPORTANT: KEEP BURNER AND CONTROL COMPARTMENT CLEAN. Make sure the "FOR YOUR SAFETY" hang tag (see below) hangs below the heat shield.

FOR YOUR SAFETY READ BEFORE LIGHTING

WARNING: If you do not follow these instructions exactly, a fire or explosion may result causing property damage, personal injury or loss of life.

- This appliance is equipped with an ignition device which automatically lights the pilot.
 - BEFORE LIGHTING** smell all around the appliance area for gas. Be sure to smell next to the floor because some gas is heavier than air and will settle on the floor.
- WHAT TO DO IF YOU SMELL GAS**
- Do not try to light any appliance or strike a match.
 - Do not touch any electric switch; do not use any phone in your building.
 - Immediately call your gas supplier from a neighbor's phone. Follow the gas supplier's instructions.
- If you cannot reach your gas supplier, call the fire department.
 - Use only your hand to push in or turn the gas control knob. Never use tools. If the knob will not push in or turn by hand, don't try to repair it, call a qualified service technician. Force or attempted repair may result in a fire or explosion.
 - Do not use this appliance if any part has been under water. Immediately call a qualified service technician to inspect the appliance and to replace any part of the control system and any gas control which has been under water.

OPERATING INSTRUCTIONS

- STOP!** Read the safety information above.
 - Turn off all electric power to the appliance (if applicable).
 - Set the thermostat to lowest setting.
 - Open control access panel.
 - This appliance is equipped with an ignition device which automatically lights the pilot. **Do not try to light the pilot by hand.**
 - Turn the gas control knob clockwise to "OFF".
 - Wait (5) minutes to clear out any gas. Then smell for gas, including near the floor. If you then smell gas, **STOP!** Follow "B" in the safety information above. If you don't smell gas, go to the next step.
 - Turn the gas control knob counter clockwise to "ON".
 - Close control access panel.
 - Turn on all electric power to the appliance (if applicable).
 - Turn thermostat to on (HEAT) position. Set thermostat higher than room temperature. Pilot will automatically light and main burner(s) will light in approximately 45 seconds.
- NOTE:** On initial start-up or after prolonged shutdown, several ignition cycles may be required to purge gas lines of air. To accomplish the recycles - repeat steps 6 thru 11 until pilot is established.
 - Set thermostat to desired setting.
 - After the room thermostat turns the system off, a delay of approximately one minute is required before the system can be turned on again.
 - If the appliance will not operate, follow the instructions "TO TURN OFF GAS TO APPLIANCE" and call your service technician or gas supplier.



TO TURN OFF GAS TO APPLIANCE

- Set the thermostat to lowest setting.
- Turn off all electric power to the appliance if service is to be performed (if applicable).
- Open the control access panel.
- Turn gas control knob clockwise to OFF. Do not force.
- Close the control access panel.

LIGHTING PILOT: (If furnace is equipped with a manual spark igniter follow next steps).

- Review all operating instructions above.
- When lighting pilot, depress red button located on the lower right side of the burner compartment (view pilot through glass observation door, repeat several times if necessary).
- If pilot fails to light or spark is not present while actuating, follow steps 5 thru 10 above.

WARNING - Do not store or use gasoline or other flammable liquids or vapors near the furnace.

WARNING - Danger of ignition flash and eye injury or blindness. Protect your eyes. Never attempt to light pilot with gas control valve knob in "ON" position. Flashback could occur.

WARNING - The surface of the furnace is hot during operation. Keep children, clothing, furniture and flammable material away.

Read owner's manual before using / installing. Be sure CHAINED LIGHTING INSTRUCTION HANGS at the lowest position in the furnace under/below the heat shield.

NOTE: FOR ADDITIONAL INFORMATION REFER TO THE INSTALLATION AND OPERATION INSTRUCTION MANUAL SUPPLIED WITH THIS APPLIANCE OR CONTACT THE MANUFACTURER IDENTIFYING THE PRODUCT BY ITS MODEL NUMBER LOCATED ON THE RATING PLATE, FOUND NEAR THE GAS VALVE.

Lighting Instructions

- STOP!** Read the safety information above.
- Set the thermostat to lowest setting.
- Turn off all electric power to the appliance.
- Remove control access panel.
- Turn gas control knob clockwise to "OFF".

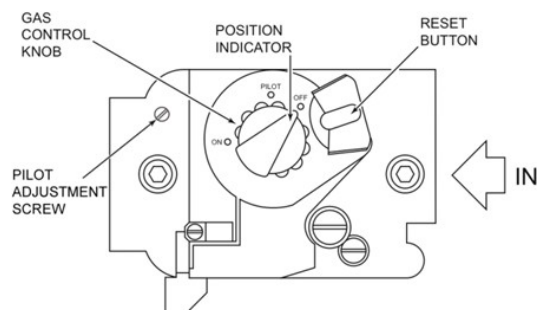

HOW TO KEEP YOUR COZY FURNACE OPERATING

- Wait five (5) minutes to clear out any gas, then smell for gas, including near the floor. **If you then smell gas, stop!** Follow "B" in the safety information above. If you don't smell gas, go to the next step.
- Loosen wing nut and open pilot observation door (If equipped).
- To find the pilot, follow the metal tube from gas control. The pilot is mounted on the side of the burner.
- Turn knob on gas control counterclockwise to PILOT
- Push in the red reset button all the way and hold in. Immediately light the pilot. Continue to hold the red reset button in for about (1) minute after the pilot is lit. Release button and it will pop back up. Pilot should remain lit. If it goes out, repeat steps 5 through 10.
 - If button does not pop up when released, stop and immediately call your service technician or gas supplier.
 - If the pilot will not stay lit after several tries, turn the gas control knob to "OFF" and call your service technician or gas supplier.
- Close the pilot observation door and tighten wing nut (if equipped).
- Turn gas control knob counterclockwise to "ON". The knob can be turned to "ON" only if red reset button is up.
- Replace the control access panel.
- Turn on all electric power to the appliance.
- Set thermostat to the desired setting.

To turn OFF gas to appliance

- Set the thermostat to lowest setting.
- Turn off all electric power to the appliance if service is to be performed (if applicable).
- Remove the control access panel.
- Push in the gas control knob slightly and turn it clockwise to "OFF". Do not Force.
- Replace the control access panel.
IMPORTANT: KEEP BURNER AND CONTROL COMPARTMENT CLEAN.

⚠ WARNING: DUE TO HIGH SURFACE TEMPERATURES, KEEP CHILDREN, CLOTHING, FURNITURE OR ANY COMBUSTIBLE MATERIAL AWAY FROM FURNACE.

How To Care For Your Furnace

⚠ WARNING: Danger of bodily injury or death. Turn off electric power supply at the disconnect switch, fuse box or service panel before removing any doors or access or service panels from the unit.

CABINET FINISH

Clean the cabinet with damp rag. Never use abrasive cleaners. Cabinets are finished in heat resistant powder coated finish DO NOT refinish with wall paint.

COMBUSTION AND VENTILATION AIR

The combustion and ventilation air supply must not be blocked.

Do not put anything in or on the furnace cabinet.

For better circulation and more effective heating, do not place obstructive furniture closer than four feet to the front of the cabinet or two feet to either side of the cabinet.

FURNACE AREA

Keep the area near the furnace clear and free from combustible materials, gasoline, and other flammable liquids and vapors.

ANNUAL UPKEEP NEEDED

It is recommended that a qualified service technician perform these checks at the beginning of each heating season.

CLEANING AND OILING

Shut off electricity, and then remove cabinet door and front panel. Clean any lint or dirt from fan blades, fan motor, and exposed air passages. Use a brush. Put 5 drops of SAE 20 oil in each of the two cups or oil tubes on the fan motor, See **Figure 36**, below.

FIGURE 36 - MOTOR OIL HOLES

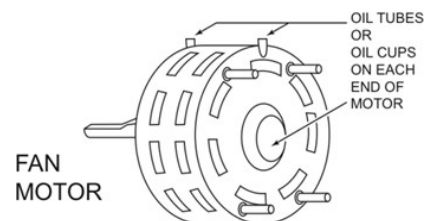

PILOT BURNER

Light pilot using instructions in OPERATING YOUR FURNACE (on pages 22 and 23, depending on your model). Leave thermostat at lowest setting.

Pilot flame should surround 3/8 to 1/2 inch of the thermocouple tip. Refer to **Figure 28, Page 25**. If flame needs adjusting, do it as follows:

CARING FOR YOUR FURNACE

ADJUST PILOT BURNER - Figure 28

1. Remove screw cover over pilot adjusting screw.
2. Insert small screwdriver, adjust flame as needed. Turn screw counterclockwise to increase flame, clockwise to decrease.
3. Turn thermostat to highest setting. Main burners should light quickly and smoothly. Turn thermostat to lowest setting. Main burners should go out. Pilot should remain lit except for electronic ignition models.
See Page 23

BURNER FLAME

Start the furnace and let it operate about 10 minutes then look at the burner flame. Flames should be soft and blue, see Fig. 28. If flames appear abnormal, contact the gas company or a qualified service technician immediately.

VENTING SYSTEM

Make sure that no parts of the vent air system are blocked or rusted. Clean or replace before using furnace.

BURNER CLEANING

Check burner. If cleaning is required, contact a qualified service technician to clean and service burner.

⚠ WARNING: Danger of bodily injury or death. Make sure electric power and gas supply are off before removing panels or doors, etc.

CLEANING BURNER COMPARTMENT

Because cold air is attracted to the flame during furnace operation, a build up of lint from bedding and dust, etc., in the burner area will occur each heating season. It is necessary to clean this area regularly. Use a vacuum cleaner with a narrow attachment to reach small areas. Be careful in and around the pilot. A change in its adjustment could be made if struck during cleaning.

⚠ WARNING: A BUILDUP OF ANY DUST, LINT OR FOREIGN MATERIAL IN THE PRIMARY AIR OPENING OF THE BURNER CAN INTERFERE WITH THE PROPER AIR GAS MIXTURE AND CAN RESULT IN A YELLOW FLAME WHICH CAN PRODUCE CARBON MONOXIDE AND SOOT. THIS CONDITION, IF ALLOWED TO DEVELOP, CAN LEAD TO BODILY INJURY INCLUDING DEATH. IT IS IMPERATIVE THAT THE BURNER(S) BE KEPT CLEAN.

TO REMOVE BURNER(S)

Disconnect gas line inside cabinet.

Refer to "Mounting Your Furnace" section, **page 17**.

Check the spark gap. It must be carefully adjusted to specifications, as illustrated **Figure 28**, for the ignition device to function properly.

FIGURE 28 - PILOT FLAME & SPARK GAP

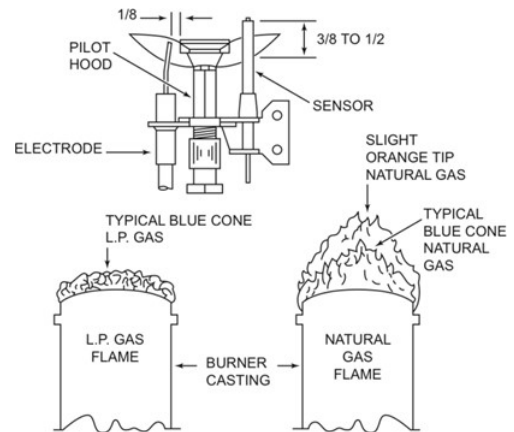

FIGURE 28 - PILOT FLAME & SPARK GAP

FURNACE TECHNICAL INFORMATION

MODEL NUMBER	GAS TPE	INPUT** RATING BTU/hr.	MAIN BURNER ORIFICE		
			DRILL	DEC.	QTY.
3508632	NATURAL	35,000	#36	.106	1
3508631	PROPANE	35,000	#50	.070	1
3508232	NATURAL	35,000	#36	.106	1
3508231	PROPANE	35,000	#50	.070	1
5008632	NATURAL	50,000	#42	.093	2
5008631	PROPANE	50,000	N/A	.060	2
5508323	NATURAL	55,000	N/A	.094	2
5508231	PROPANE	55,000	N/A	.062	2
6508632	NATURAL	65,000	#36	.106	2
6508631	PROPANE	65,000	#51	.067	2

The efficiency rating of these appliances is a product of a thermal efficiency rating system determined under continuous operating conditions and was determined independently of any installed system.

**For elevations above 2,000 feet reduce ratings 4% for each 1,000 feet above sea level.

**BTU/hr. = British Thermal Units per hour.

GAS CONVERSION KITS

NATURAL GAS TO PROPANE GAS

MODEL	DESCRIPTION
7716	35082 SERIES
7718	35086 SERIES
7720	50086 SERIES
7722	55082 SERIES
7726	65086 SERIES

GAS CONVERSION KITS

PROPANE NATURAL GAS

MODEL	DESCRIPTION
7717	35082 SERIES
7719	35086 SERIES
7721	50086 SERIES
7723	55082 SERIES
7727	65086 SERIES

FORSAIRE HARDWIRE ACCESSORY 9940

Installation Instructions

THIS KIT IS FOR USE WITH MODELS:

3508231 / 3508232 / 3508631 / 3508632 / 4007331 / 4007332 / 4007731 / 4007732 / 5008631 / 5008632 / 5507331 / 5507332 / 5508231 / 5508232 / 6007731 / 6007732 / 6508631 / 6508632

⚠ WARNING: Danger of bodily injury. Turn off electric power supply at disconnect switch, fuse box or service panel before working on the furnace.

SUMMARY: This accessory converts Williams' Forsaire Counterflow furnaces using the electric service cord provided, to a hardwired, permanent electrical connection.

If this furnace is equipped or has been previously installed and operated using the service power cord, disconnect the cord at the receptacle connector located at the base of the

furnace and remove the cord completely from the furnace.

Following the wiring diagram below, make all the necessary wiring connections from an outside electrical source. All electrical work must conform to your local codes and ordinances or in their absence, with National Electrical Code, ANSI/NFPA 70 or in Canada, Canadian Electrical Code C22.1. If you are not familiar with wiring codes in general, have a competent electrician do this job. Be sure this accessory is of the type and design required for use with your furnace.

The 40077 model series with a single speed motor is shown in the wiring diagram below. The required field wiring connections are applicable to all models listed above. For internal wiring connections to your model, refer to the wiring diagram attached to the furnace.

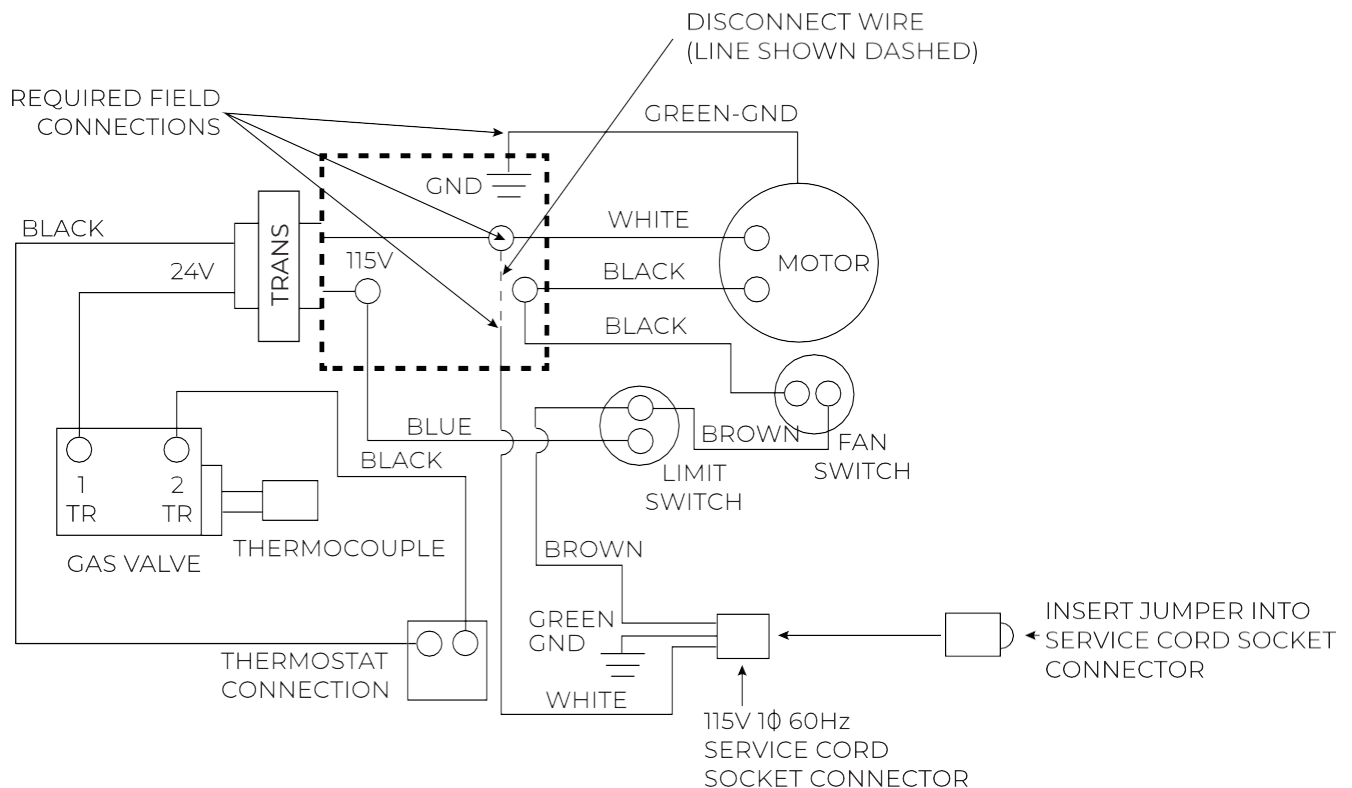

WIRING DIAGRAMS

MODELS - 3508231 / 3508232

FOR 35M B.T.U. FAN TYPE VENTED WALL FURNACE WITH INTERMITTENT IGNITION CONTROL SYSTEM

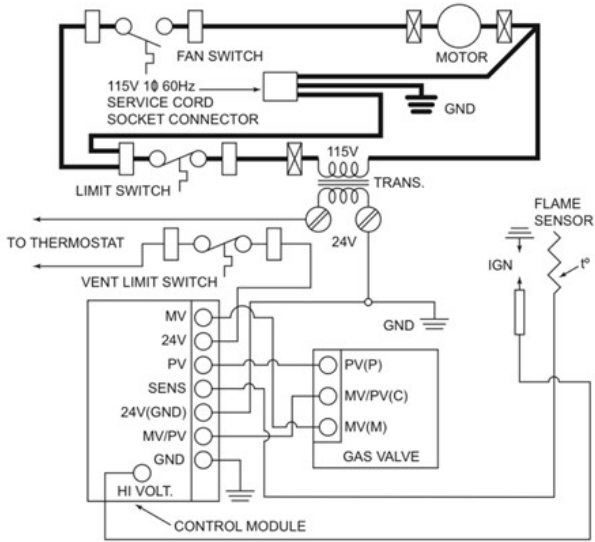

MODELS - 5508231 / 5508232

FOR 55M B.T.U. FAN TYPE VENTED WALL FURNACE WITH INTERMITTENT IGNITION CONTROL SYSTEM

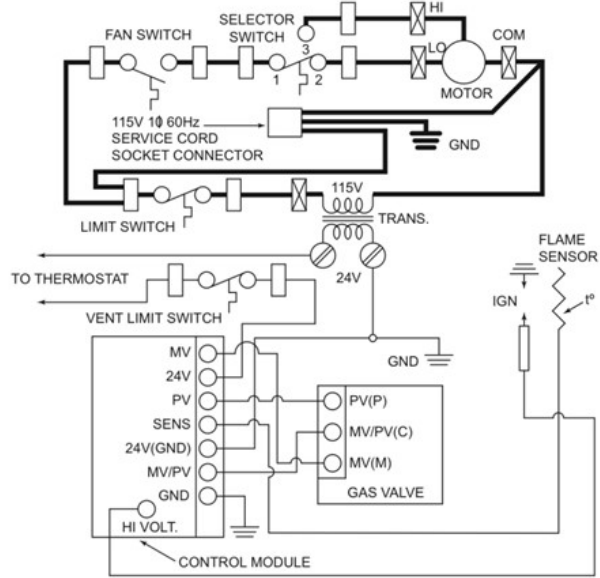

LEGEND

- FACTORY WIRED LINE VOLTAGE.
- FACTORY WIRED LOW VOLTAGE.
- 1/4 QUICK CONNECT TERMINAL FOR FACTORY WIRING.
- ⊗ WIRE CONNECTOR FOR FACTORY WIRING LINE VOLTAGE.
- ⊙ SCREW TERMINAL LOW VOLTAGE.
- FACTORY WIRED CONNECTION

NOTES:

1. IF ANY OF THE ORIGINAL WIRE AS SUPPLIED WITH THE APPLIANCE MUST BE REPLACED, IT MUST BE REPLACED WITH TYPE AWM 105°C. 18 GA. WIRE 4/64 INSULATION OR EQUIVALENT.
2. MOTOR IS THERMALLY OVERLOAD PROTECTED. 115V. 10/60Hz. - LESS THAN 3 AMPS.

LEGEND

- FACTORY WIRED LINE VOLTAGE.
- FACTORY WIRED LOW VOLTAGE.
- 1/4 QUICK CONNECT TERMINAL FOR FACTORY WIRING.
- ⊗ WIRE CONNECTOR FOR FACTORY WIRING LINE VOLTAGE.
- ⊙ SCREW TERMINAL LOW VOLTAGE.
- FACTORY WIRED CONNECTION

NOTES:

1. IF ANY OF THE ORIGINAL WIRE AS SUPPLIED WITH THE APPLIANCE MUST BE REPLACED, IT MUST BE REPLACED WITH TYPE AWM 105°C. 18 GA. WIRE 4/64 INSULATION OR EQUIVALENT.
2. MOTOR IS THERMALLY OVERLOAD PROTECTED. 115V. 10/60Hz. - LESS THAN 3 AMPS.

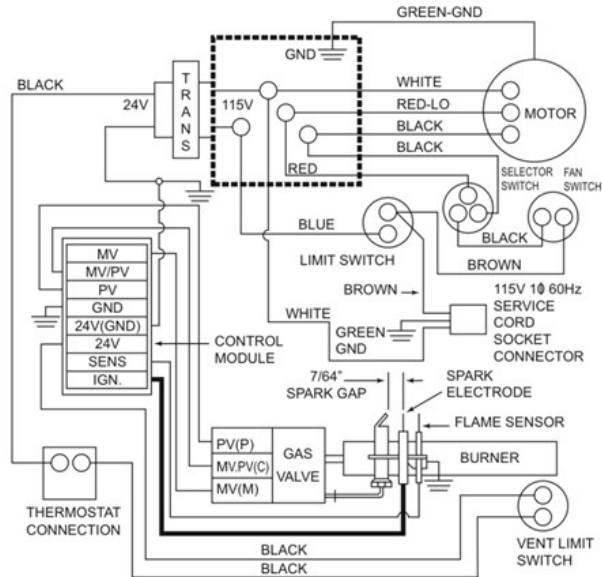
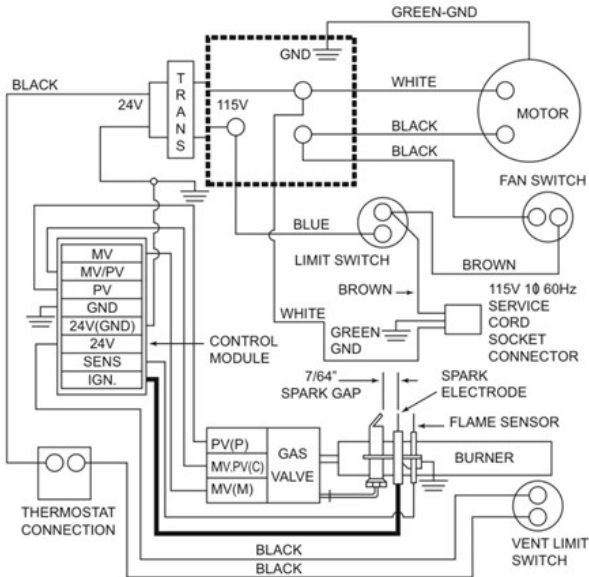

MODELS - 3508631 / 3508632

FOR 35M B.T.U. FAN TYPE VENTED WALL FURNACE WITH STANDING PILOT CONTROL SYSTEM

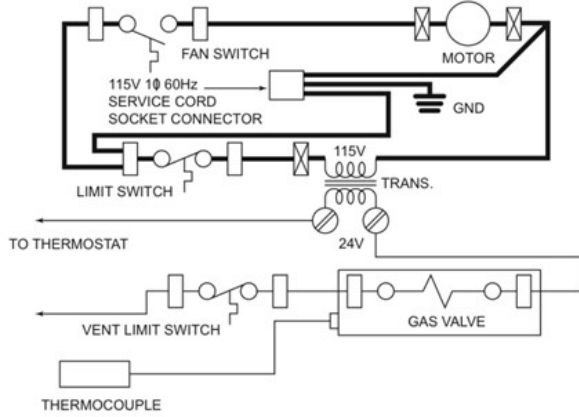

LEGEND

- FACTORY WIRED LINE VOLTAGE.
- FACTORY WIRED LOW VOLTAGE.
- 1/4 QUICK CONNECT TERMINAL FOR FACTORY WIRING.
- ⊗ WIRE CONNECTOR FOR FACTORY WIRING LINE VOLTAGE.
- ⊙ SCREW TERMINAL LOW VOLTAGE.
- FACTORY WIRED CONNECTION

NOTES:

1. IF ANY OF THE ORIGINAL WIRE AS SUPPLIED WITH THE APPLIANCE MUST BE REPLACED, IT MUST BE REPLACED WITH TYPE AWM 105°C. 18 GA. WIRE 4/64 INSULATION OR EQUIVALENT.
2. MOTOR IS THERMALLY OVERLOAD PROTECTED. 115V. 10 60Hz. - LESS THAN 3 AMPS.

**MODELS - 5008631 / 5008632
6508631 / 6508632**

FOR 50M, 60M, 65M, B.T.U. FAN TYPE VENTED WALL FURNACE WITH STANDING PILOT CONTROL SYSTEM

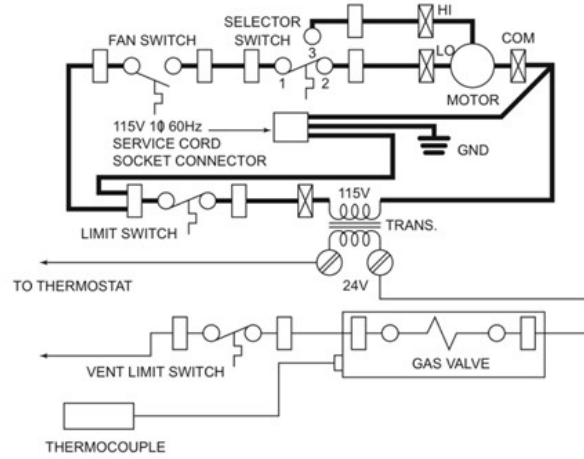

LEGEND

- FACTORY WIRED LINE VOLTAGE.
- FACTORY WIRED LOW VOLTAGE.
- 1/4 QUICK CONNECT TERMINAL FOR FACTORY WIRING.
- ⊗ WIRE CONNECTOR FOR FACTORY WIRING LINE VOLTAGE.
- ⊙ SCREW TERMINAL LOW VOLTAGE.
- FACTORY WIRED CONNECTION

NOTES:

1. IF ANY OF THE ORIGINAL WIRE AS SUPPLIED WITH THE APPLIANCE MUST BE REPLACED, IT MUST BE REPLACED WITH TYPE AWM 105°C. 18 GA. WIRE 4/64 INSULATION OR EQUIVALENT.
2. MOTOR IS THERMALLY OVERLOAD PROTECTED. 115V. 10 60Hz. - LESS THAN 3 AMPS.

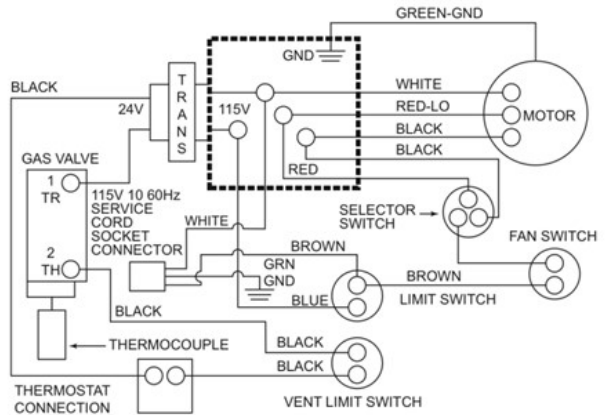
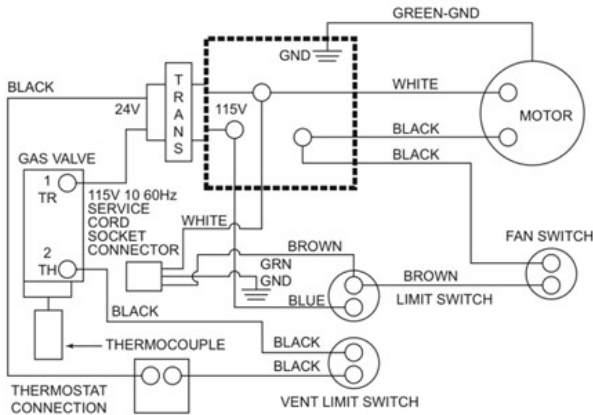

PART NUMBERS FOR THE 350 MODEL

TOP VENT COUNTERFLOW				
NATURAL		PROPANE		
3508232		3508632	3508231	3508631
REF. NO.	REPLACEMENT PART DESCRIPTION	3508232 / 3508231 / 3508632 / 3508631		
1	Outer Casing, Less Front Panel	12C10		
2	Inner Liner	12B15		
3	Heating Element	12C26		
4	Bottom Front Panel	12B49		
5	Top Front Panel	12B50		
6	Fan Shroud	12B03-1		
7	Opening Pan	12B12		
8	Switch Box	11B05		
9	Switch Box Cover	11C68		
10	Center Front Panel	12C21		
11	Internal Wires (All Except Ign. Control)	3508231		
12	Header Plate	7B57		
13	Junction Box	12B05		
14	Gasket-Element Base	P026500		
15	Draft Hood Gasket	P107900		
16	Flue Collar Gasket	7A22		
17	Fan Blade	P300500		
18	Motor	P322544		
19	Motor Support (2 Req.)	7B46		
20	Vibration Isolators (4 Req.)	P022800		
21	Transformer 115V-24V	P024200		
22	Limit Switch	P309600		
23	Fan Switch	P200200		
24	Limit Switch	7735		
25	Deflector Baffle Handle	11C63		
26	Lower Element Base Angle	7A117		
27	KIT 12" Vent Enclosure	9812		
28	KIT 24" Vent Enclosure	9824		
29	KIT Rear Grille, Two-Way	6802		
30	KIT Diffusing Grille - Two-Way	6703		
31	KIT Diffusing Grille - One-Way	6704		

EXPLODED VIEW & REPLACEMENT PARTS CHART

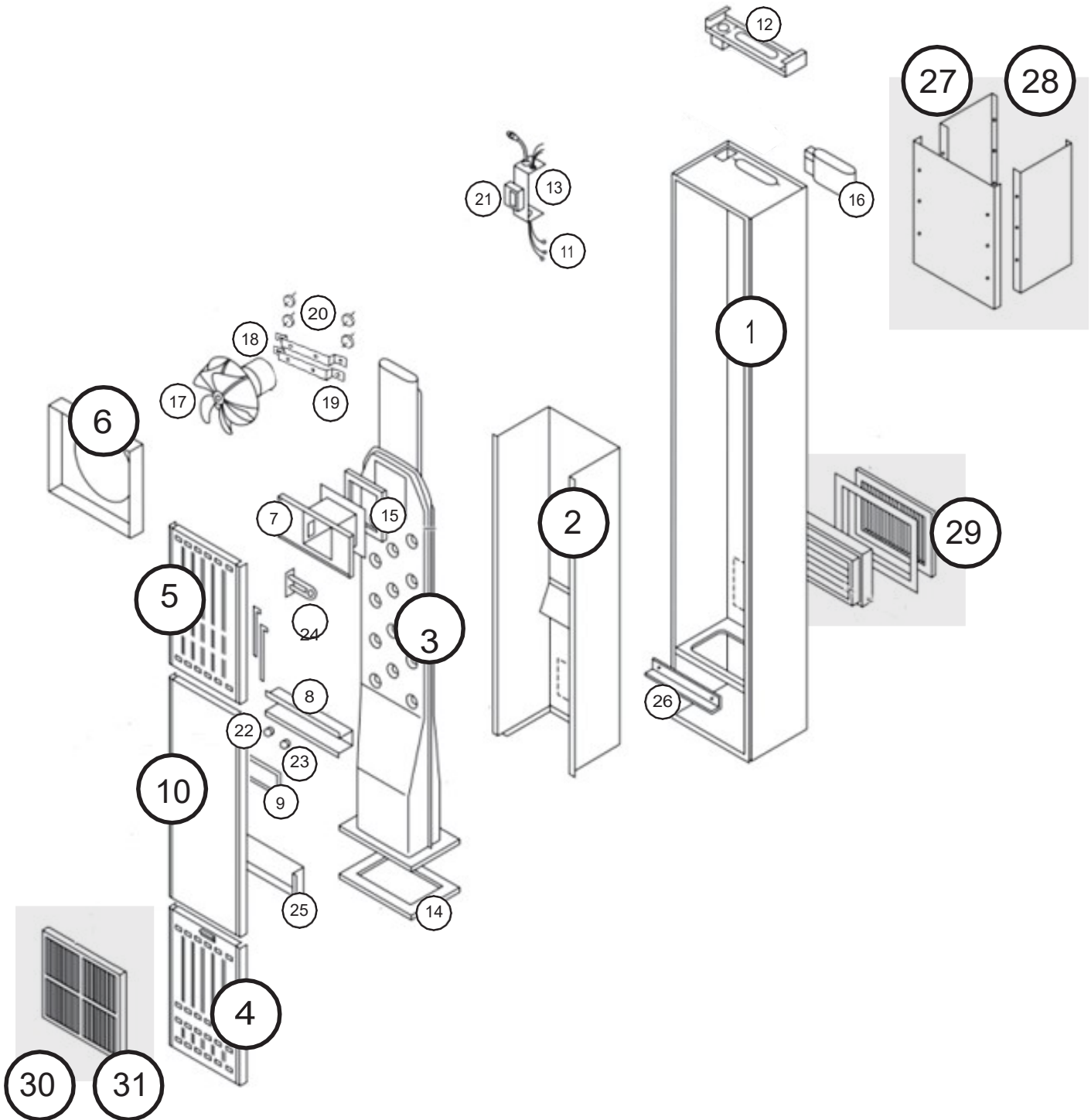

Thermostat not included with these models.

CONTROL ASSEMBLY REPLACEMENT PARTS 350 MODELS - INTERMITTENT IGNITION

REF. NO.	REPLACEMENT PART DESCRIPTION	MODEL NUMBERS	
		3508232	3508231
1	Valve, Natural Gas	P323210	–
	Valve, Liquid Propane Gas	–	P322044
2	Manifold	P323657	P323657
3	Orifice Fitting, Specify Model & Gas Type	P090536	P090550
4	Pilot, Natural Gas	P323418	–
	Pilot, Liquid Propane Gas	–	P323419
5	Thermocouple	–	–
	Flame Sensor	P271100	P271100
6	50mm BURNER	P323648	P323648
7	Ignition Control Unit	P321900	P321900
8	Wire Assembly	P321935/35A	P321935/35A
9	Ignition Control Wires	31B036	31B036
10	Manifold Adapter	P321887	P321887
11	Ignition Shield	11B155	11B155
12	Front Burner Bracket	9B234	9B234

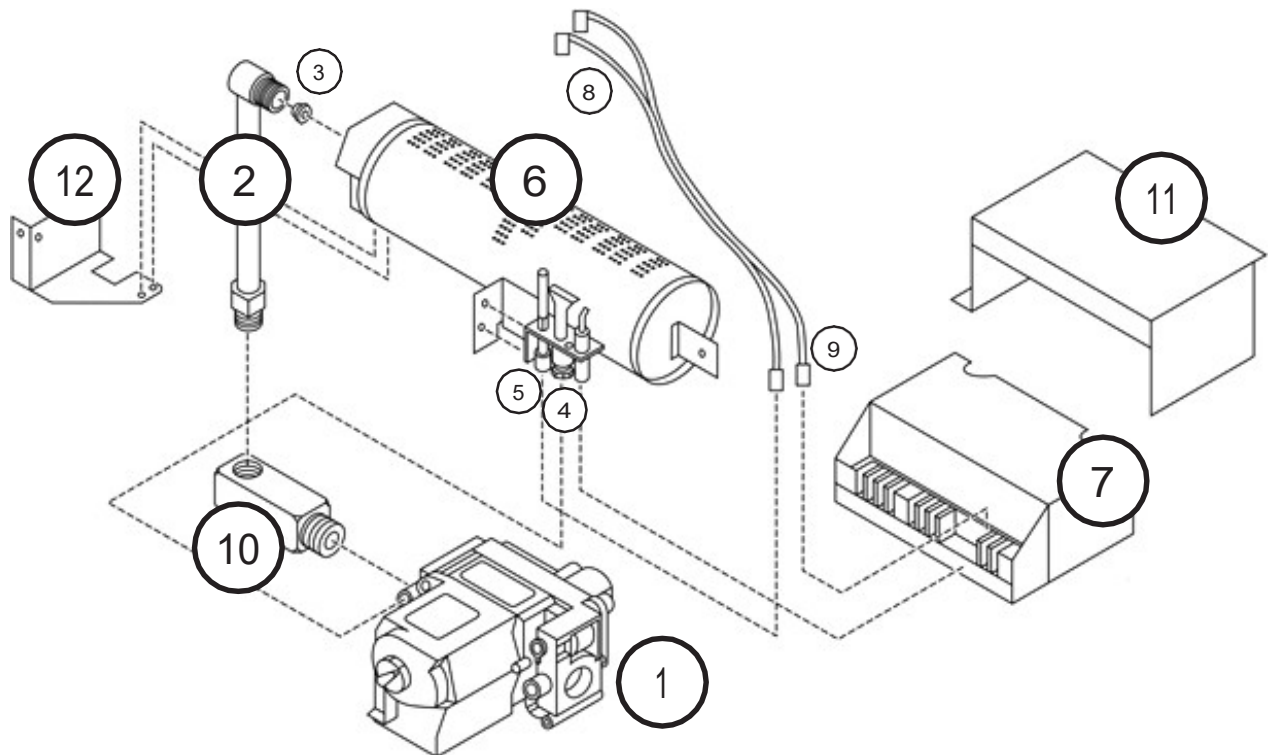

CONTROL ASSEMBLY REPLACEMENT PARTS 350 MODELS - **STANDING PILOT**

REF. NO.	REPLACEMENT PART DESCRIPTION	MODEL NUMBERS	
		3508632	3508631
1	Valve, Natural Gas	P323209	–
	Valve, Liquid Propane Gas	–	P322042
2	Manifold	P323657	P323657
3	Orifice Fitting, Specify Model & Gas Type	P090536	P090550
4	Pilot, Natural Gas	P323074	–
	Pilot, Liquid Propane Gas	–	P323073
5	Thermocouple	P233100	–
	Flame Sensor	–	–
6	50mm BURNER	P323648	P323648
7	Wire Assembly	P321935/35A	P3219535/35A
8	Ignition Control Wires	–	–
9	Manifold Adapter	P321888	P321888
10	Front Burner Bracket	9B234	9B234
11	Manual Spark Igniter	P285500	P285500
12	Piezo Igniter Bracket	7A189	7A189
13	Pal Nut	P285501	P285501

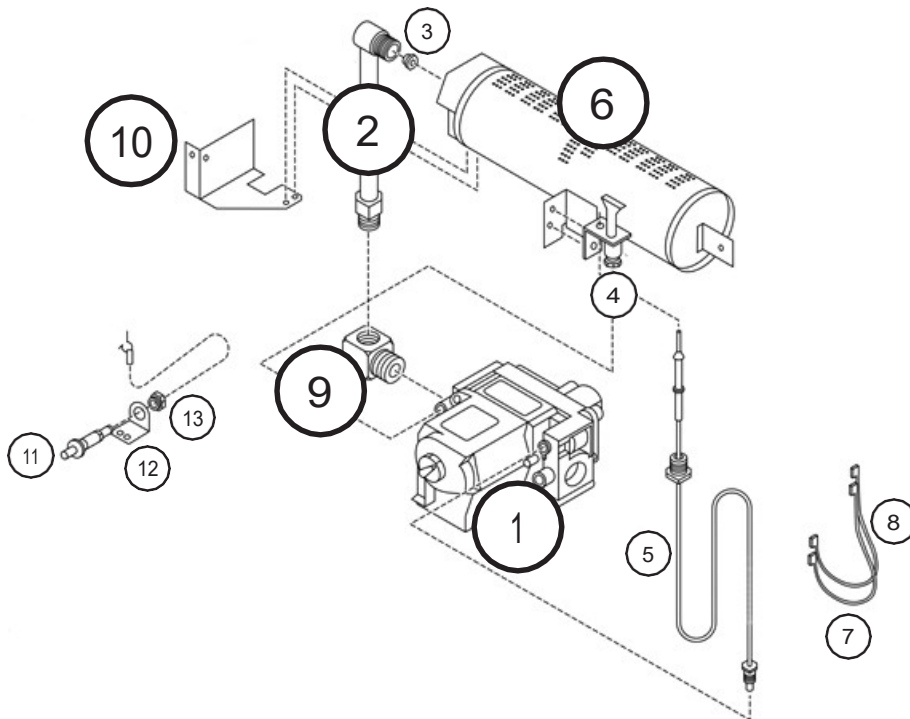

PART NUMBERS FOR THE 500 / 550 / 650 MODELS

TOP VENT COUNTERFLOW					
NATURAL			PROPANE		
5008632	5508232	6508632	5008631	5508231	6508631

REF. NO.	REPLACEMENT PART DESCRIPTION	5008632 / 5008631	5508232 / 5508231	6508632 / 6508631
1	Outer Casing, Less Front Panel	7C55-2	–	–
2	Inner Liner	11B46	7B79	7B79
3	Heating Element	7C116	7C68	7C117
4	Relief Opening Pan	7B108	7B107	7B108
5	Top Front Panel	7B126	7B126	7B126
6	Center Front Panel	11C60	11C59	11C59
7	Switch Box	11B05	11B05	11B05
8	Limit Switch	P200300	P296001	P309600
9	Selector Switch	P213400	P296201	P296201
10	Fan Switch	P200200	P200200	P200200
11	Bottom Front Panel	11B158	11B158	11B158
12	Element Base Gasket	P026500	P026500	P026500
13	Fan Shroud	7B106	7B106	7B106
14	Relief Pan Gasket	P028300	P028300	P028300
15	Flue Collar Gasket	7A22	7A22	7A22
16	Header	7B57	7B57	7B57
17	Limit Switch	7735	7735	7735
18	Switch Box Cover	11C68	11C68	11C68
19	Lower Element Base Angle	7A117	7A117	7A117
20	Transformer, 115V/24V	P024200	P024200	P024200
21	Junction Box	7B29	7B29	7B29
22	Internal Wires (All Except Ign. Control)	5008632	5008232	6508632
23	Vibration Isolators (4 Req.)	P022800	P022800	P022801
24	Motor Support (2 Req.)	7B46	7B46	7B46
25	Motor	P062101	P062101	P321601
26	Motor Fan Blade	P200600	P200600	7B111
27	Deflector Baffle Handle	11C63	11C63	11C63
28	KIT 12" Vent Enclosure Kit*	9812	9812	9812
29	KIT 24" Vent Enclosure Kit	9824	9824	9824

REF. NO.	REPLACEMENT PART DESCRIPTION	5008632 / 5008631	5508232 / 5508231	6508632 / 6508631
30	KIT Rear Grille, Two-Way, outer boot 10" long, inner boot 10 3/4" long	6801	6801	6801
31	KIT Rear Grille, Two-Way, outer boot 7/8" long, inner boot 1 5/8" long	6802	6802	6802
32	KIT Diffusing Grille Kit (Two-Way) Diffusing Grille Kit (One-Way)	6703 6704	6703 6704	6703 6704
33	KIT Side inner Boot, 10 3/4" long Side Outlet Register Kit 10" long Side Plaster Ground Side Grille	6701	6701	6701
Thermostat not included with these models.				

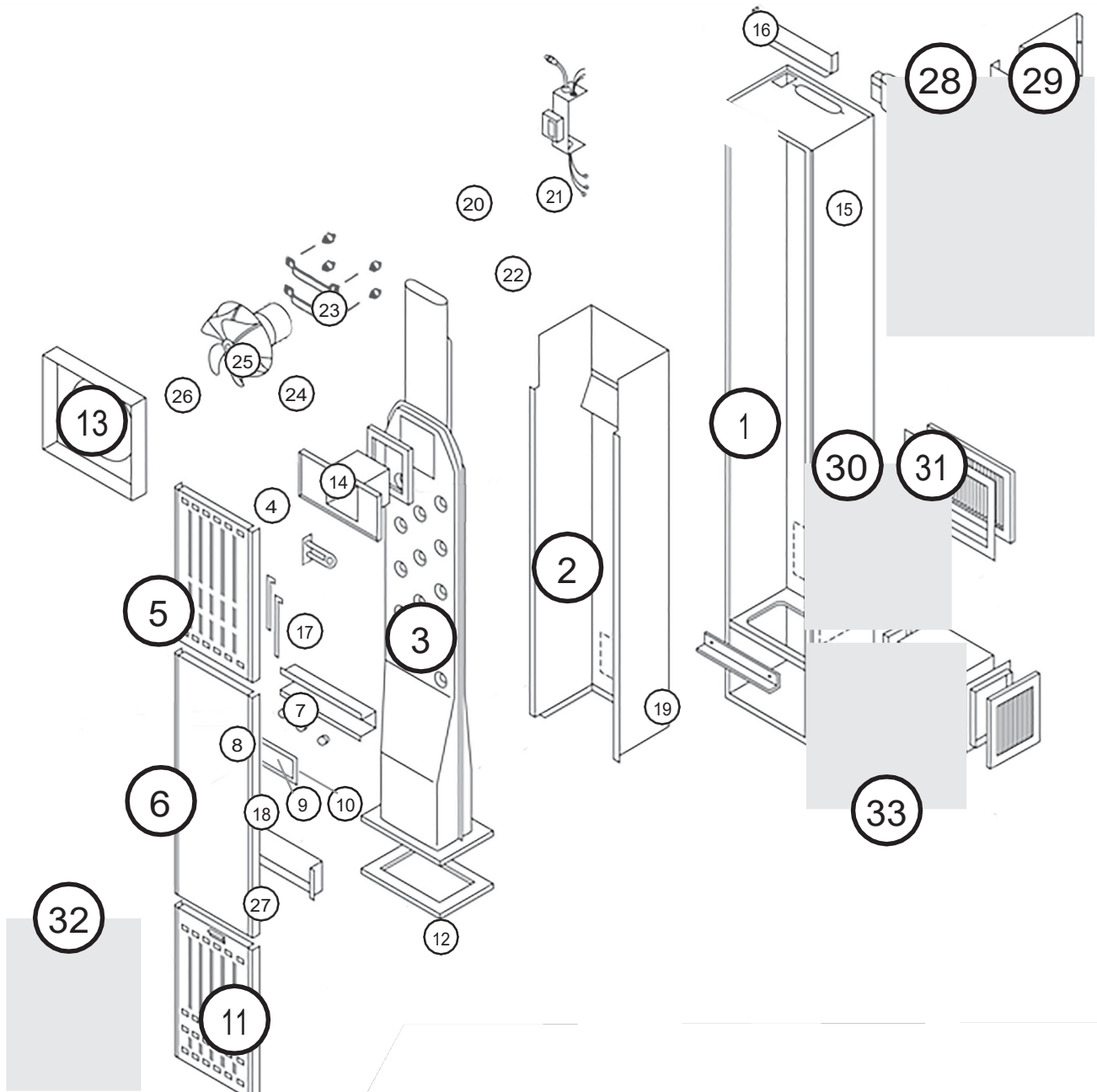

CONTROL ASSEMBLY REPLACEMENT PARTS 550 MODELS - INTERMITTENT IGNITION

REF. NO.	REPLACEMENT PARTS DESCRIPTION	MODEL NUMBERS	
		5508232	5508231
1	Manifold	P323656	P323656
2	Orifice Fitting, Specify Model and Gas (2 required)	P332622	P332620
3	Valve, Natural Gas	P323210	–
	Valve, Liquid Propane Gas	–	P322044
4	Thermocouple	P322042	–
	Flame Sensor	P233100	P271100
5	Pilot, Liquid Propane Gas	P323073	P322680
6	50mm Burner (with pilot bracket)	P323648	P323648
7	50mm Burner (without pilot bracket)	P323649	P323649
8	Ignition Control Unit	P321900	P321900
9	Wire Assembly	P322048/48A	P322048/48A
10	Ignition Control Wires	31B036	31B036
11	Manifold Adapter	P321887	P321887
12	Ignition Shield	11B155	11B155
13	Burner Mounting R.H. Bracket Assembly	7B187	7B187

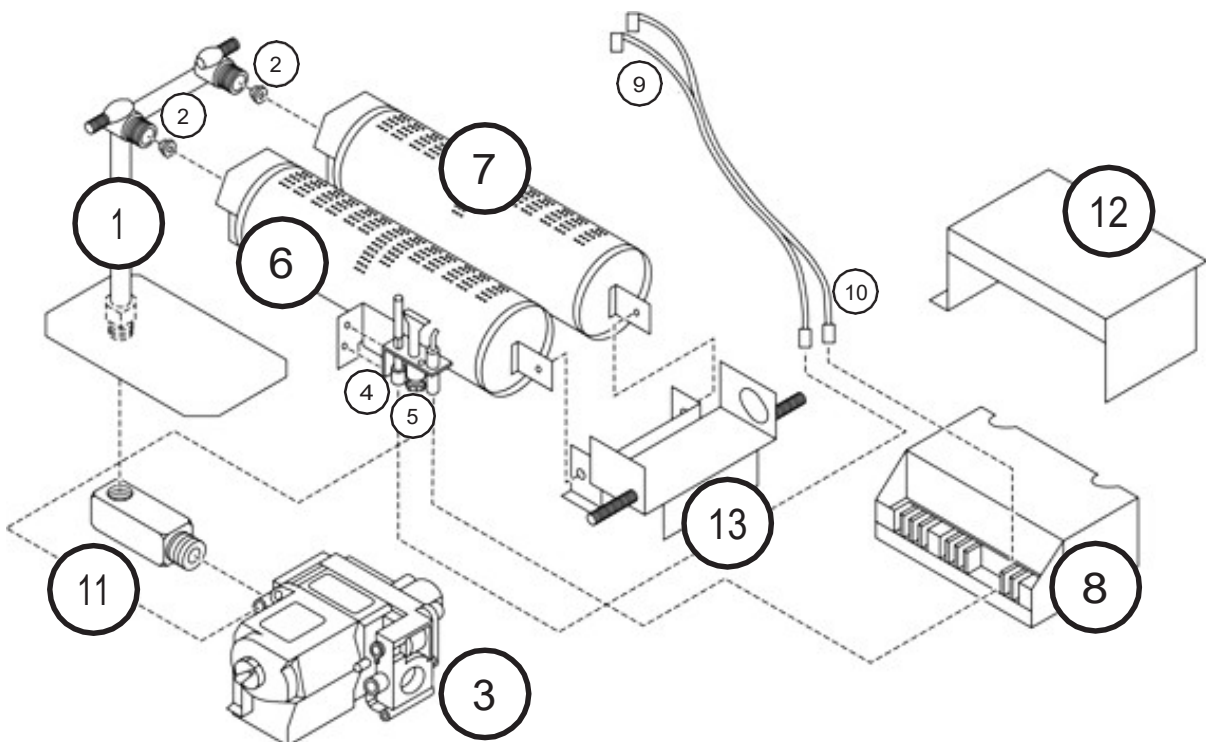

CONTROL ASSEMBLY REPLACEMENT PARTS 500 / 650 MODELS - **STANDING PILOT**

REF. NO.	REPLACEMENT PARTS DESCRIPTION	MODEL NUMBERS			
		5008632	5008631	650832	6508631
1	Manifold	P323656	P323656	P323656	P32656
2	Orifice Fitting, Specify Model and Gas (2 required)	P090542	P332619	P090536	P090551
3	Valve, Natural Gas	P323209	–	P323209	–
	Valve, Liquid Propane Gas	–	P322042	–	P322042
4	Thermocouple	P233100	P233100	P233100	P233100
5	Pilot, Natural Gas	P323074	–	P323074	–
	Pilot, Liquid Propane Gas	–	P323073	–	P323073
6	50mm Burner (with pilot bracket)	P323648	P323648	P323648	P323648
7	50mm Burner (without pilot bracket)	P323649	P323649	P323649	P323649
8	Wire Assembly	P322048/48A	P322048/48A	P322048/48A	P322048/48A
9	Manifold Adapter	P321888	P321888	P321888	P321888
10	Burner Mounting R.H. Bracket Assembly	7B187	7B187	7B187	7B187
11	Manual Spark Igniter	P285500	P285500	P285500	P285500
12	Piezo Igniter Bracket	7A303	7A303	7A303	7A303
13	Pal Nut	P285501	P285501	P285501	P285501

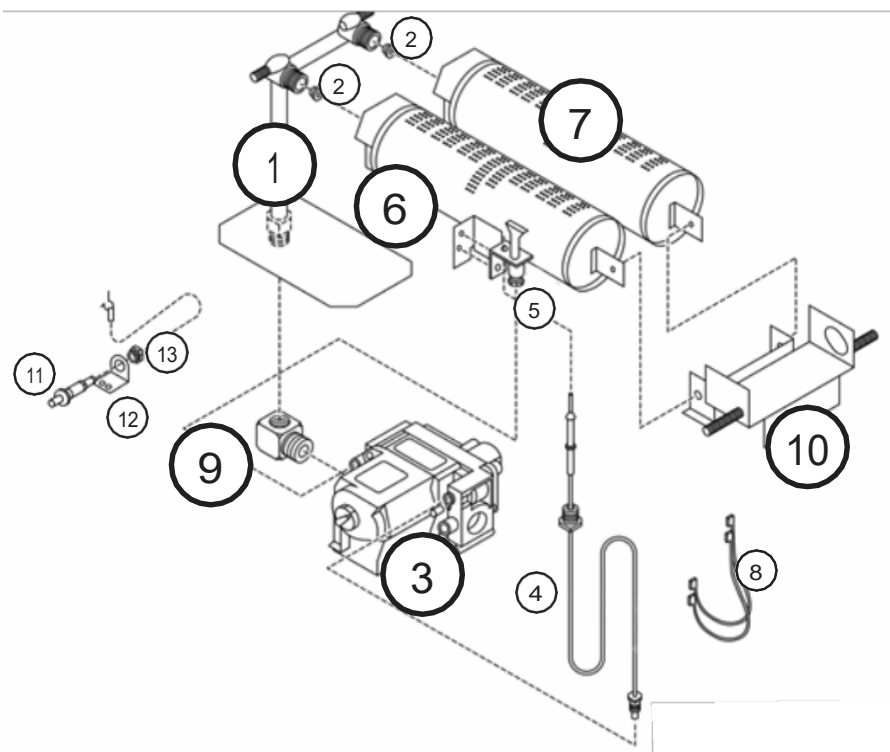

TROUBLESHOOTING YOUR FURNACE

For qualified service technicians. **FOR MODELS: 3508631 / 3508632 / 5008631 / 5008632 / 6508631 / 6508632**

* Also applicable to Models equipped with an electric intermittent pilot system.

ISSUE	POSSIBLE CAUSE(S)	CORRECTIVE ACTION
1. Pilot will not stay lit after following lighting instructions.	A. Thermocouple producing insufficient millivolts.	A. Check pilot flame – it must impinge on thermocouple. Pilot flame may be low or blowing (high) causing safety to drop out. Pilot orifice or aerating hole may be plugged (check for spiders, webs or other organic material). Be sure the thermocouple is fully inserted in its bracket.
	B. Loose or dirty thermocouple connection at gas valve.	B. Clean and/or tighten the thermocouple fitting at the connection to the valve.
	C. Thermocouple defective.	C. Check thermocouple with millivolt meter – it should generate approximately 30 millivolts when not connected to a load. When connected to a load, it should generate approximately 14 millivolts. If below 7 millivolts, replace.
	D. Thermomagnet pilot safety defective	D. Replace gas valve after above is checked out.
	E. Vent safety shutoff	E. Check wiring connections from valve to the vent safety shutoff device. Be sure all connections are tight. Check for blocked or incorrect venting.
2. Main burner will not come ON (pilot burning and thermostat set for heat).	A. Gas valve not turned ON after lighting the pilot.	A. Turn gas valve knob to 'ON' position (if no main gas flow, proceed to Step "B").
	B. Electric power to furnace turned OFF.	B. Check for line voltage at furnace (if okay and no main gas flow, proceed to Step "C").
	C. Low voltage transformer or limit switch defective.	C. Check for 24 volts at the low voltage terminals of the transformer. If no voltage, turn OFF electric power to furnace. Remove one wire from limit switch and check for continuity across both terminals. No continuity – replace limit switch. With a good limit switch back in the circuit and the electric power turned ON (if no voltage, replace transformer. NOTE: Before replacing the transformer or limit switch, check wiring for loose connections or broken wires and repair as needed. If voltage is present at transformer, proceed to Step "D").
	D. Wall thermostat defective.	D. With thermostat set for heat (contacts closed) check for voltage at terminals on gas valve. If no voltage is present replace defective thermostat. NOTE: Before replacing thermostat, be sure to check the wiring from the furnace to thermostat for loose connections or broken wires and replace as needed.
	E. Burner orifice plugged.	E. Clean or replace orifice (if okay and still no gas flow to main burners, proceed to Step "F").
	F. Gas valve defective.	F. Replace defective gas valve.
3. Burner comes "ON" but goes OFF before blower turns ON.	A. Defective wiring.	A. Turn OFF electric power to furnace. Remove top front panel, fan shroud and blower wheel. Refer to Wiring Diagram and check all wiring inside junction box. Remove center front panel and check all wiring inside switch box containing fan, limit and selector switches. Correct if necessary. If correct, proceed to Step "B". NOTE: Selector switch used only on Models 5008731 / 5008732 / 6508731 / 6508732.
	B. Defective limit switch.	B. If burner goes OFF in less than five minutes from room temperature start, check limit control switch. If defective, replace. NOTE: Blower should turn "ON" within three minutes after burner is "ON" from a room temperature start. If not, proceed to Step "C".
	C. Defective motor (2 speed).	C. Jumper across the fan switch, turn electric power ON, the motor should rotate. If a 2-speed motor is used. Jumper from "brown" terminal on the fan switch to #2 (red) terminal on the selector switch, motor should rotate on "LOW" speed. Jumper from same "brown" terminal on the fan switch to #3 (black) terminal on the selector switch, motor should rotate on "HIGH" speed. Replace motor if defective.
	D. Defective motor (1 speed).	D. Jumper across fan switch, turn electric power ON, motor should rotate. Replace motor if defective.
	E. Detective fan switch.	E. If, after checking above possibilities, problem still exists, replace fan switch.
4. Burner comes "ON", blower comes "ON", but cycles "ON" and "OFF" while burner remains "ON".	A. Furnace not operating at full rate.	A. Check for low gas pressure at gas valve (should be 4" W.C. for Natural Gas, 11" W.C. for propane gas. Check burner orifice).
5. Burner comes "ON", blower comes "ON", but burner cycles "OFF" and "ON" with blower "ON".	A. Furnace operating over-rate.	A. Check for high gas pressure at gas valve (correct if necessary. See correct pressure above).
	B. Line voltage too low.	B. Check line voltage to motor, if below 115 volts motor will run too slow.
	C. Recirculation.	C. Heated air discharging against an object causing recirculation, such as a hall installation or a large piece of furniture within 4' of discharge.

ISSUE	POSSIBLE CAUSE(S)	CORRECTIVE ACTION
	D. Loss of circulating air due to leakage.	D. Check header plate installation and proper use of gaskets. Repair as necessary.
6. Furnace operates but turns "OFF" before room temperature is attained.	A. Thermostat location. B. Defective thermostat.	A. Check location of thermostat. It should not be in the path of warm air discharge from the furnace, near a lamp, or above a TV set or stereo. B. Check thermostat calibration or replace.
7. Furnace operates but will not shut "OFF" when room temperature is attained.	A. Thermostat wiring defective. B. Thermostat location. C. Improper thermostat anticipator setting.	A. Check thermostat wiring from furnace to thermostat - may be shorted to gether by a nail or staple. B. Check thermostat location - if on an outside wall or there is a hole in wall behind the thermostat causing cold air to contact thermostat, relocate the thermostat. C. Set anticipator per THERMOSTAT ANTICIPATOR, page 19-20.
8. Abnormal operation.	A. Blower noise. B. Expansion noise ticking. C. Burner resonance. D. Selector switch defective (2 speed).	A. Check motor mounts - they may be loose. Blower wheel could be out of balance. Set screw may be loose on motor shaft. Blower may be rubbing on fan shroud. Motor may need oiling. Correct as needed. B. Check installation. Casing may be twisted or not level at time of installation causing combustion chamber to bind on its locating pins. C. Usually associated with propane gas operation. Adjust primary air screw in throat of each cast iron burner after about 10 minutes of operation. Adjust to obtain a soft blue flame without streaming yellow tips. D. During normal furnace operation the motor will be on "LOW" speed when operating on minimum input capacity and on "HIGH" speed when operating at maximum input capacity. If there is no change in motor speed, replace selector switch.

FOR MODELS: 3508231 / 350232 / 550231 / 5508232

* Also applicable to Models equipped with an electric intermittent pilot system.

1. No spark - no pilot gas.	A. No main power. Faulty transformer. Faulty thermostat. Faulty limit switch. Faulty ignition control. B. Faulty wiring. C. Vent safety shutoff device	A. Perform normal system checks of main power, transformer, thermostat, limit switch, and replace faulty component. With power ON, turn thermostat to the lowest setting, wait for 10 seconds and return to HIGH setting. With power ON and thermostat set at its highest position, set voltmeter to 24V scale and attach probes to terminals "TR" and "TH" on the ignition control unit. If you read 24V and there still is no spark or pilot gas, the ignition control is defective and must be replaced. B. Test wiring. Repair or replace. C. Check wiring connections from valve to vent safety shutoff device, be sure all connections are tight. Check for blocked vent.
2. Spark - but no pilot gas.	A. Faulty ignition. B. No gas supplied to pilot valve. Manual valves in OFF position. Faulty pilot valve. C. Faulty wiring. D. Restricted pilot line or clogged pilot orifice.	A. See 1E. B. Check for availability of gas at gas control. Make sure the manual valve (gas cock) on the gas control are in the full ON position. No pilot gas could be caused by plugged pilot tubing. Also check the pilot adjustment at the gas control. C. See 1F. D. See 2B.
3. Pilot gas - but no spark.	A. Faulty ignition control.	A. With power ON, turn the thermostat to the lowest setting, wait for 10 seconds and then return it to the high setting. With power ON and thermostat set at its highest position, set voltmeter to 24V scale and attach probes to terminals "24V" (*TH) and "GRD" (*TR) on the ignition control unit. If you read 24V and there is still no spark or pilot gas, the ignition control is defective and must be replaced. With thermostat turned to its highest setting, set test meter to 24V scale. Touch probes to "PV/MV" and "PV" terminals on Gas Valve. If you do not get a 24V reading, check wiring. If wiring tests okay, check ignition control. Connect probes to "PV/MV" AND "PV" terminals on ignition control. If you do not read 24V, the ignition control must be replaced.

TROUBLESHOOTING YOUR FURNACE

For qualified service technicians. **FOR MODELS: 3508231 / 350232 / 5508231 / 5508232** (continued from previous page)

* Also applicable to Models equipped with an electric intermittent pilot system.

ISSUE	POSSIBLE CAUSE(S)	CORRECTIVE ACTION
4. Pilot lit, but main burner won't come ON.	B. Broken or Shorted electrode assembly.	B. Remove wire at "PV/MV" terminal at the ignition control, being careful not to touch any metal parts; disconnect the electrode wire at the ignition control. Connect one end of a jumper wire to terminal "GND" (DO NOT REMOVE EXISTING WIRE). Attach the other end of the jumper wire to the metal blade of a small screwdriver. Position end of metal blade approx. 1/8" from terminal. Reconnect "PV/MV" terminal. Sparking should occur between screwdriver blade and terminal. If no sparking occurs, the ignition control must be replaced. Check the pilot and electrode assembly for proper electrode gap (3/32" to 1/8") or any possible shorting of electrode to surrounding metal surfaces. Make sure the spark igniter and electrode connections to the ignition control are tight. The ignition control and pilot burner must both be chassis ground. If there is still no spark, the pilot and electrode assembly must be replaced.
5. Pilot cycles OFF and ON by itself.	A. Faulty ignition control. B. Faulty wiring. C. Low pilot flame. D. Improper alignment of sensor in pilot flame. E. Faulty Flame sensor.	A. See 3A B. See 1F C. NOTE: Wait at least 90 seconds after pilot lights before doing the check out procedures for problem number 4. With thermostat ON, be sure that the pilot and sensor are properly aligned so that the pilot flame impinges the top 3/4 inch of the sensor. Be sure that the sensor is pushed all the way into pilot bracket. Adjust pilot flame with pilot adjustment, if necessary. Also check inlet supply pressure and pilot orifice. If pilot hood or sensor is bent, the defective unit should be replaced. If main burner still won't come ON, make sure the main burner orifices are clear. If orifices are clear, set voltmeter to 24V scale and touch probes to the terminals of the main gas operator on the gas valve. Attach to terminal "MV", "PV/MV" on Gas Valve. If you read 24V and the burner won't turn ON, replace entire gas valve. D. When main burner comes ON, ensure that the pilot flame is strong, sensor is properly aligned, and pilot flame impinges the top 3/4 inch of the sensor. (See procedures for check for proper pilot flame and alignment in problem 4c.) Check the pilot and electrode assembly for proper electrode gap (3/32" to 1/8") or any possible shorting of electrode to surrounding metal surfaces. Make sure the spark igniter and electrode connections to the ignition control are tight. The ignition control and pilot burner must both be chassis ground. If there is still no spark, the pilot and electrode assembly must be replaced. E. BE SURE POWER IS "OFF" BEFORE PERFORMING THIS TEST!! Set test meter to "ohm" scale or use continuity checker. Touch one end of probes to top of flame sensor, the other to "SENSE" terminal on the ignition control. Ohmmeter should read "0", continuity should be evident. If you don't obtain a reading, remove wiring from sensor and test both individually. If continuity is not evident, replace wiring and/or sensor. There should be NO continuity between sensor and "GND" terminal on the ignition control. Testing wiring and sensor individually, determine which is shorted on ground. Replace or repair. Turn ON power.
6. Main burner shuts down before thermostat is satisfied.	A. Faulty pilot valve. B. Faulty wiring. A. Low pilot flame B. Improper alignment of sensor in pilot flame. C. Pilot flame being drawn away from sensor. D. Improper heat anticipator setting. E. Faulty limit.	A. See 2B B. See 1F A. See 4C B. See 4D C. When main burner comes ON, ensure that the pilot flame is strong, sensor is properly aligned and pilot flame impinges the top 3/4 inch of the sensor. (See procedures for checking for proper pilot flame and alignment in problem 4d.) If the pilot flame is drawn away from the sensor when the main burner comes "ON" the cause could be the manual valve is not in the full ON position or the inlet gas pressure with the main burner ON. NOTE: Low inlet gas pressure to the gas control can be caused by several problems and is not within the scope of the procedures outlined in this service guide. Consult your local utility or gas supplier. D. See 6c. Check the setting of the heat anticipator in the wall thermostat. Set it to setting specified on the gas control. E. The system may be cycling on a faulty limit. Using a test meter set to the 110 volt scale, check for a voltage reading across the limit when the main burner shuts OFF. If you get a 24 volt or 110 volt reading on shutdown, replace defective limit switch.

INSTALLATIONS IN THE STATE OF MASSACHUSETTS

All installations in the State of Massachusetts must use the following requirements when installing, maintaining or operating direct-vent propane or natural gas-fired space heaters.

For direct-vent appliances, mechanical-vent heating appliances or domestic hot water equipment, where the bottom of the vent terminal and the air intake is installed below four feet above grade the following requirements must be satisfied:

1. If there is not one already present, on each floor level where there are bedroom(s), a carbon monoxide detector and alarm shall be placed in the living area outside the bedroom(s). The carbon monoxide detector shall comply with NFPA 720 (2005 Edition).
2. A carbon monoxide detector shall be located in the room that houses the appliance or equipment and shall:
 - a. Be powered by the same electrical circuit as the appliance or equipment such that only one service switch services both the appliance and the carbon monoxide detector.

- b. Have battery back-up power;
- c. Meet ANSI/UL 2034 Standards and comply with NFPA 720 (2005 Edition); and
- d. Have been approved and listed by a Nationally Recognized Testing Laboratory as recognized under 527 CMR.

A CARBON MONOXIDE DETECTOR SHALL:

- a. Be located in the room that houses the appliance or equipment;
 - b. Be either hard-wired or battery powered or both; and
 - c. Shall comply with NFPA 720 (2005 Edition).
3. A product-approved vent terminal must be used, and if applicable, a product-approved air intake must be used. Installation shall be in strict compliance with the manufacturer's instructions. A copy of the installation instructions shall remain with the appliance or equipment at the completion of the installation.
 4. A metal or plastic identification plate shall be mounted at the exterior of the building, four feet directly above the location of vent terminal. The plate shall be of sufficient size to be easily read from a distance of eight

HINTS AND INFORMATION

If your furnace fails to work correctly, you may avoid the inconvenience and cost of a service call by checking the troubleshooting section on **page 36-38** before you call for service.

⚠ WARNING: If the information in this manual is not followed exactly, a fire or explosion may result causing property damage, personal injury or loss of life.

DO NOT store or use gasoline or other flammable vapors and liquids in the vicinity of this or any other appliance.

HOW TO ORDER REPAIR PARTS

When ordering repair parts, always give the following information:

1. MODEL NUMBER
2. MFG. DATE CODE
3. PART NUMBER
4. PART DESCRIPTION

All parts listed herein may be ordered from your equipment supplier. The Model Number of your Williams wall furnace will be found on the nameplate near gas valve, inside control compartment.

WHAT TO DO IF YOU SMELL GAS

- Open all of the windows.
- Do not try to light any appliance.
- Do not touch any electrical switch.
- Do not use any phone or cell phone in your building.
- Extinguish any open flame.
- Immediately call your gas supplier from a neighbor's phone. If you cannot reach your gas supplier, call the fire department.

Installation and service must be performed by a qualified installer, service agency or the gas supplier.

SERVICE RECORD

DATE	MAINTENANCE PERFORMED	COMPONENTS REQUIRED

NOTES

||||| WILLIAMS™



DESIGNED
& ASSEMBLED
IN THE USA
SINCE 1916