

RESIDENTIAL



EASE OF INSTALLATION AND SERVICEABILITY

- Compact Design to Save Space
- Wi-Fi Technology for Remote Monitoring and Management
- Simple Gas Conversion

OPTIONAL ACCESSORIES

ScaleCutter, Additional Controllers, Recess Box, Pipe Cover, EZConnect™ Cables, control-r™ Wi-Fi Module, Wireless Accessories, and many more.

Visit rinnai.us for a complete list of accessories.

HIGH-EFFICIENCY (NON-CONDENSING) TANKLESS WATER HEATER

Installation Type	External (Outdoor) Residential Applications; Certified for installation in Manufactured (Mobile) Homes	
Model Number	V94e (REU-VC2837W-US)	
Approved Gas Types	Natural and Propane	
High Altitude Approved	Up to 10,200 ft. (3,109 m)	
Water Flow Control	Water Flow Sensor, Electronic Water Control and Fixed Bypass Control	
Efficiency	 UEF: 0.81	
	Ratings not certified by AHRI	EF: 0.82
Controller	Included: MC-91-2US Optional: MC-100V-1US (Deluxe), BC-100V-1US (Bathroom), MCC-91-2US (Hydronic Applications), control-r™ Wi-Fi Module	
Certifications	AHRI, ANSI Z21.10.3, and CSA 4.3	

Warranty

- Heat Exchanger: 10 years* for residential and hydronic applications, increased to 12 years* if installed with an isolation valve kit
- All Other Parts and Components: 5 Years*
- Reasonable Labor: 1 Year

* 3 years if used as a circulation water heater within a circulation loop when the water heater is in series with a circulation system and all circulating water flows through the water heater. Refer to the Tankless Water Heater Installation and Operation manual for complete warranty information.

Safety Devices

Flame Failure - Flame Rod, Boiling Protection, Combustion Fan RPM Check, Over Current - Glass Fuse, Remaining Flame (OHS), Thermal Fuse and Automatic Frost Protection

Included with Purchase

Tankless Water Heater and MC-91-2 Temperature Controller

Additional Features

- Complies with South Coast Air Quality Management District 14 ng/J or 20 ppm NOx Emission Levels
- Ultra Low NOx
- 1/2 in. (13 mm) Gas Line Compatible
- Wi-Fi Capable



CERTIFIED TO ANSI Z21.10.3 — CSA 4.3

TECHNICAL SPECIFICATIONS

SPECIFICATION		V94e
Dimensions - w, h, d		14.04 in. x 22.95 in. x 9.27 in. (356.6 mm x 583 mm x 235.5 mm)
Minimum Gas Consumption Btu/h		10,300
Maximum Gas Consumption Btu/h		199,000
Flow Rate ¹ (Min - Max)		0.26 - 9.8 GPM (1.0 - 37.1 L/min)
Weight		44.3 lbs. (20.1 kg.)
Sound Level		55 dB
Electrical	Normal	65 W
	Standby	2 W
	Freeze Protection	104 W
	Max	4 Amps
	Fuse	10 Amps
Temperature (with remote)		98° - 120° F (37°C - 49°C) (factory default) 98° - 160° F (37° - 71° C) available with the MCC-91-2 controller for hydronic applications
Temperature (without remote)		120° F (49°C) (factory default) or 140° F (60°C)
Gas Supply Pressure ²		<ul style="list-style-type: none"> Natural: 4 in. w.c. - 10.5 in. w.c. (10 mbar – 26.1 mbar) Propane: 8 in. w.c. - 13.5 in. w.c. (20 mbar – 33.6 mbar)
Ignition System		Direct Electronic Ignition
Electronic Connections		<ul style="list-style-type: none"> Appliance: AC 120 Volts, 60Hz. Temperature Controller: DC 12 Volts (Digital)
Water Supply Pressure		<ul style="list-style-type: none"> Minimum: 20 PSI (Recommended 30-80 PSI for max performance) Maximum: 150 PSI
Controller Cable		Non-Polarized Two Core Cable (Minimum 22 AWG)
Service Connections		<ul style="list-style-type: none"> Gas Supply: 3/4 in. (19 mm) NPT Cold Water Inlet: 3/4 in. (19 mm) NPT Hot Water Outlet: 3/4 in. (19 mm) NPT
Clearances from Combustibles		<ul style="list-style-type: none"> Top: 12 in. (305 mm) Bottom/Ground: 12 in. (305 mm) Front (Panel): 24 in. (610 mm) Back: 0 in. Sides: 6 in. (152 mm) Front (Exhaust): 24 in. (610 mm)
Clearances from Non-Combustibles		<ul style="list-style-type: none"> Top: 2 in. (51 mm) Bottom/Ground: 2 in. (51 mm) Front (Panel): 24 in. (610 mm) Back: 0 in. Sides: 1/8 in. (3.2 mm) Front (Exhaust): 0 in.*

* Clearance for servicing is 24 in. (610 mm) in front of water heater

¹ Minimum flow may vary slightly depending on the temperature setting and the inlet water temperature. Minimum activation flow is 0.4 GPM (1.5 L/min).

² The maximum gas supply pressure must not exceed the value specified by the manufacturer.

WATER FLOW CURVE

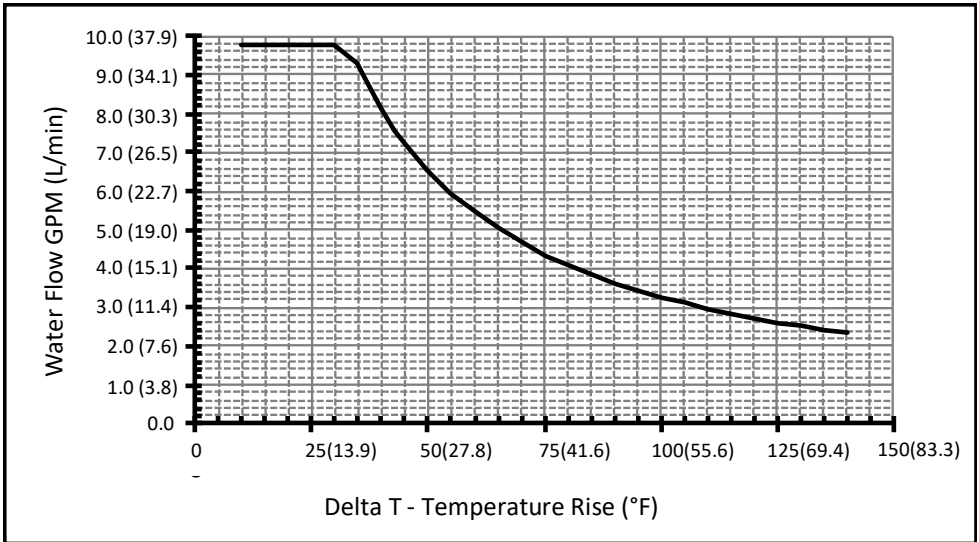

DIMENSIONS

in. (mm)

FRONT

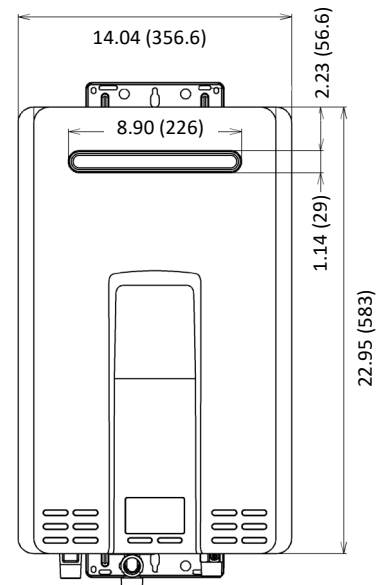

SIDE

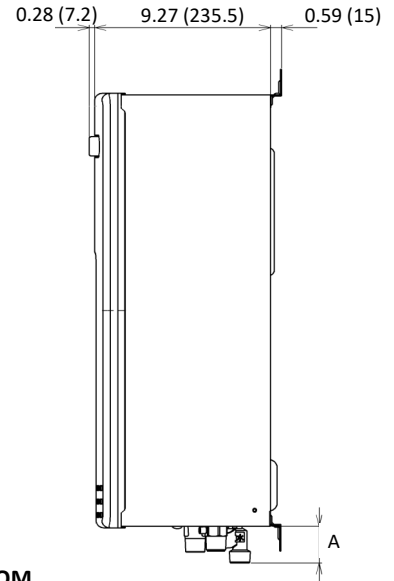

BOTTOM

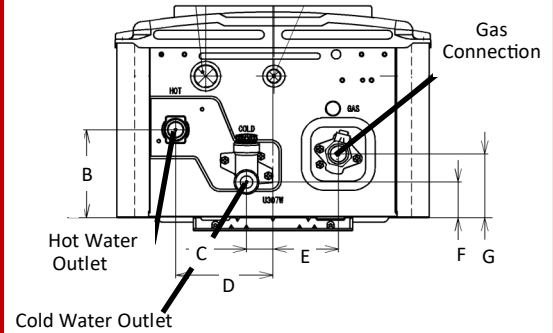

DIMENSION	Inches (mm)	DIMENSION	Inches (mm)
A (GAS)	1.31 (33.2)	D	4.33 (110)
A (COLD)	1.93 (49)	E	2.91 (73.8)
A (HOT)	1.35 (34.4)	F	1.61 (40.8)
B	3.96 (100.7)	G	2.87 (73)
C	1.17 (29.8)		