



OWNER'S MANUAL

INSTALLATION INSTRUCTIONS

VISITE NUESTRA PÁGINA WEB PARA LA VERSIÓN EN ESPAÑOL DE ESTE MANUAL
<https://www.williamscomfortprod.com/products/furnaces/>

FLOOR FURNACES

MODEL NUMBERS (natural gas)
4505622A / 6005622A

MODEL NUMBERS (propane gas)
4505621A / 6005621A

SAVE THIS MANUAL FOR FUTURE REFERENCE.

READ THIS OWNER'S MANUAL CAREFULLY BEFORE YOU
INSTALL YOUR NEW WILLIAMS WALL FURNACE.



45,000 - 60,000 BTU/hr.



! WARNING: Do not install any of these furnaces (natural or propane gas) in mobile homes, trucks or recreational vehicles.

! WARNING: This product can expose you to chemicals including epichlorohydrin which is known to the State of California to cause cancer and birth defects and/or other reproductive harm. For information go to www.p65warnings.ca.gov

! WARNING: Improper installation, adjustment, alteration, service or maintenance can cause injury or property damage. Refer to this manual. For assistance or for additional information consult a qualified installer or, service agency.

! WARNING: Installation and repair must be done by a qualified service person. The appliance should be inspected before use and at least annually by a professional service person.

! WARNING: If the information in these instructions is not followed exactly, a fire or explosion may result causing property damage, personal injury or loss of life.

- Do not store or use gasoline or other flammable vapors and liquids in the vicinity of this or any other appliance.

WHAT TO DO IF YOU SMELL GAS:

- Open all windows.
- Do not try to light any appliance.
- Do not touch any electrical switch; do not use any phone or cell phone in your building.
- Extinguish any open flame.
- Immediately call your gas supplier from a neighbor's phone. Follow the gas supplier's instructions.
- If you cannot reach the gas supplier, call the fire department.
- Installation and service must be performed by a qualified installer, service agency or the gas supplier.

WARRANTY

The manufacturer, Williams Furnace Co., warrants this wall furnace or heater to the original purchaser under the following conditions:

ANY WARRANTY CONSIDERATIONS ARE CONTINGENT ON INSTALLATION BY A QUALIFIED INSTALLER (CONTRACTOR). SELF-INSTALLATION IS PROHIBITED AND WILL INVALIDATE YOUR WARRANTY.

LIMITED ONE-YEAR WARRANTY

1. Any part thereof which proves to be defective in material or workmanship within one year from date of original purchase for use will be replaced at the Manufacturer's option, FOB to its factory.
2. No liability is assumed by the Manufacturer for removal or installation labor costs, nor for freight or delivery charges.

LIMITED EXTENDED WARRANTY

1. In addition to the above limited one year warranty on the complete unit, any combustion chamber which burns out or rusts under normal installation, use and service conditions during a period of nine years following expiration of the one-year warranty period will be exchanged for a like or functionally similar part.
2. No liability is assumed by the Manufacturer for removal or installation labor costs, nor for freight or delivery charges.

LIMITATIONS

1. THIS LIMITED WARRANTY IS THE ONLY WARRANTY MADE BY THE MANUFACTURER, IMPLIED WARRANTIES OF MERCHANTABILITY OR FITNESS FOR ANY PARTICULAR PURPOSE ARE LIMITED TO THE SAME ONE YEAR TERM AS THE EXPRESS WARRANTY. UNDER NO CIRCUMSTANCES SHALL THE MANUFACTURER BE LIABLE FOR INCIDENTAL, CONSEQUENTIAL, SPECIAL OR CONTINGENT DAMAGES OR EXPENSES ARISING DIRECTLY OR INDIRECTLY FROM ANY DEFECT IN THE PRODUCT OR ANY COMPONENT OR FROM THE USE THEREOF. THE REMEDIES SET FORTH HEREIN ARE THE EXCLUSIVE REMEDIES AVAILABLE TO THE USER AND ARE IN LIEU OF ALL OTHER REMEDIES.

Some states do not allow limitation on how long an implied warranty lasts, and some states do not allow the exclusion or limitation of incidental or consequential damages, so the above limitations or exclusions may not apply to you.

2. This warranty does not include any charge for labor or installation.
3. This warranty does not extend to painted surfaces or to damage or defects resulting from accident, alteration, misuses or abuse or improper installation.
4. This warranty does not cover claims which do not involve defective workmanship or materials.

DUTIES OF THE CONSUMER

1. The heating equipment must be installed by a qualified installer and operated in accordance with the installation and homeowner's instructions furnished with the equipment.
2. Any travel, diagnostic costs, service labor, and labor to repair the defective unit will be the responsibility of the owner.
3. A bill of sale, canceled check, payment record or permit should be kept to verify purchase date to establish the warranty period.
4. Have the installer enter the requested information in the space below.

GENERAL

1. The manufacturer neither assumes nor authorizes any person to assume for it any other obligation or liability in connection with said equipment.
2. Service under this warranty should be obtained by contacting your dealer. Provide the dealer with the model number, serial number, and purchase date verification.
3. If, within a reasonable time after contacting your dealer, satisfactory service has not been received, contact: Customer Service Department, 250 West Laurel Street, Colton, CA 92324 for assistance.
4. THIS WARRANTY GIVES YOU SPECIFIC LEGAL RIGHTS AND YOU MAY ALSO HAVE OTHER RIGHTS WHICH VARY FROM STATE TO STATE.

INSTALLATION RECORD

Model No. _____ Serial No. _____

Original Purchaser _____

Address _____

City and State _____ Zip _____

Dealer _____

Address _____

City and State _____ Zip _____

Installation Date _____ Name _____ Signature _____

(Dealer or authorized representative who certifies that this appliance is installed in accordance with Manufacturer's instructions and local codes.)

CONTENTS

YOUR WILLIAMS WARRANTY	2
INSTALLATION RECORD	2
TABLE OF CONTENTS	3
SAFETY RULES	4
BUILDING CODES AND SAFETY STANDARDS	5
INTRODUCTION	6
INSTALLING YOUR FURNACE	7
VENTING AND CHIMNEY REQUIREMENTS	8
GAS SUPPLY AND PIPING REQUIREMENTS	9
INSTALLATION	10
THERMOSTAT CONNECTIONS	11
FLAME ADJUSTMENT	12
START-UP PROCEDURE	12
OPERATING YOUR FURNACE	13
CARING FOR YOUR FURNACE	15
FURNACE ACCESSORY REPLACEMENT PARTS	16
TROUBLESHOOTING YOUR FURNACE	18
HINTS AND INFORMATION	19

SAFETY RULES

⚠ WARNING: Read these rules and the instructions carefully. Failure to follow these rules and instructions could cause a malfunction of the furnace. This could result in death, serious bodily injury and/or property damage.

INSTALLATION MUST CONFORM TO LOCAL CODES. IN THE ABSENCE OF LOCAL CODES, INSTALLATION MUST CONFORM TO THE NATIONAL FUEL GAS CODE, ANSI Z223.1. THE APPLIANCE, WHEN INSTALLED MUST BE ELECTRICALLY CONNECTED AND GROUNDED IN ACCORDANCE WITH LOCAL CODES OR, IN THE ABSENCE OF LOCAL CODES, WITH THE CURRENT NATIONAL ELECTRICAL CODE ANSI/NFPA NO. 70.

IN CANADA:

1. Installation must conform to local codes or, in the absence of local codes, the current CAN/CGA B149 installation code.
 2. The appliance, when installed, must be electrically connected and grounded in accordance with local codes or, in the absence of local codes, with the current CSA C22.1 Canadian Electrical code.
 3. Field conversions for high altitude are not permitted in Canada.
 4. Reference is made in this manual regarding gas type as propane gas. Be advised that propane gas is not available in Canada, refer to propane.
1. Use only manufacturer's replacement parts. Use of any other parts could cause injury or death.
 2. DO NOT install the furnace in an alcove.
 3. DO NOT install this furnace where it could be isolated by closing doors to the heated space.
 4. DO NOT install this furnace in a travel trailer or recreational vehicle.
 5. MAINTAIN all clearances specified in section "Locating Wall furnace and Thermostat" and "Vent Installation."
 6. BE SURE this furnace is for the type of gas to be used. Check the rating plate by the gas valve in the lower cabinet. Do not change it to use other gases without the proper manufacturer's Gas Conversion Kit.
 7. For natural gas, the minimum inlet gas supply pressure for the purpose of input adjustment is 5" water column. The maximum inlet gas supply pressure is 7" water column.
For propane gas, the minimum inlet gas supply pressure for the purpose of input adjustment is 11" water column. The maximum inlet gas supply pressure is 13" water column.
 8. Any safety screen, guard or parts removed for servicing this appliance must be replaced prior to operating
- the appliance to avoid property damage, bodily injury or death.
9. Install the furnace vent directly to the outdoors, so that harmful gases will not collect inside the building. Follow the venting instructions for your type of installation exactly. Use only the type and size of vent pipe and fittings specified.
 10. BE SURE to provide for adequate combustion and ventilation air. The flow of this air to the furnace must not be blocked.
 11. NEVER vent flue gases into another room, a fireplace or any space inside a building. This could cause property damage, bodily injury or death.
 12. Never test for gas leaks with an open flame. Use a soap solution to check all gas connections. This will avoid the possibility of fire or explosion.
 13. ALLOW the furnace to cool before servicing. Always shut off electricity and gas to the furnace when working on it. This will prevent any electrical shocks or burns.
 14. DUE TO HIGH TEMPERATURES, locate the furnace out of traffic and away from furniture and draperies.
 15. ALERT children and adults to the hazards of high surface temperatures and warn them to keep away to avoid burns or clothing ignition.
 16. CAREFULLY supervise young children when they are in the same room with the furnace.
 17. DO NOT place clothing or other flammable material on or near furnace.
 18. INSTALLATION and REPAIR must be done by a qualified service person. The appliance should be inspected before use and at least annually by a professional service person. More frequent cleaning may be required due to excessive lint from carpeting, bedding material, etc. It is important that control compartments, burners and circulating air passages be kept clean. Failure to keep burner-control compartment and other parts of furnace clean can cause dangerous conditions to develop which can cause injury and even death.
 19. BE AWARE of good safety practices by wearing personal protective equipment such as gloves and safety glasses to avoid being injured by sharp metal edges in or around furnace and while cutting or drilling holes in wood and/or sheet metal.
 20. CAUTION: Label all wires prior to disconnection when servicing controls. Wiring errors can cause improper and dangerous operation. Verify proper operation after servicing.
 21. DO NOT store or use gasoline or other flammable liquids or vapors near the furnace.

⚠ WARNING: Do not use this furnace if any part has been under water. Immediately call a certified service technician to inspect the furnace and to replace any part of the control system and any gas control which has been under water.

BUILDING CODES AND SAFETY STANDARDS

THE DESIGN OF THIS FURNACE IS NOT CERTIFIED FOR USE IN MOBILE HOMES, TRAVEL TRAILERS OR CAMPERS. THIS FURNACE MUST BE PROPERLY VENTED TO THE OUTSIDE FOR SAFE OPERATION. DO NOT OPERATE THIS FURNACE WITHOUT AN ADEQUATE VENTING SYSTEM.

THE DESIGN OF THIS APPLIANCE COMPLIES WITH ANSI Z21.86.

THE SECTIONS OF THIS MANUAL PERTAINING TO VENTING AND GAS PIPING PROVIDE ONLY BASIC GUIDELINES. BE SURE THE INSTALLATION OF THE VENT AND GAS PIPING COMPLIES WITH LOCAL CODES. IN THE ABSENCE OF LOCAL CODES, BE SURE TO COMPLY WITH THE NATIONAL FUEL GAS CODE ANSI Z223.1.

IMPORTANT GENERAL INFORMATION

Read these instructions completely before beginning the installation and use these instructions as a guide during the installation. Your furnace has been carefully designed and constructed. The design of this furnace has been tested

according to the standards set by the American National Standards Institute, and the design has been certified by CSA as conforming to these standards. Care has been taken to assure that your furnace will operate safely, efficiently, and reliably, but your furnace must be properly installed.

Only a licensed or otherwise qualified gas equipment installer should install this furnace, the vent serving this furnace, and the gas piping. Installation procedures should comply with these instructions and the latest edition of the American National Standard National Fuel Gas Code Z223.1. You should also refer to any local codes or ordinances which may apply. Improper installation of the furnace, vents or gas piping, can subject you and your property to fire, explosion, or asphyxiation hazards and will void the warranty offered by Williams Furnace Co. Do not be satisfied with an improper installation.

Do not use this furnace if any part has been under water. Immediately call a qualified service technician to inspect the furnace and to replace any part of the control system and any gas control which has been under water.



WARNING: CARBON MONOXIDE POISONING HAZARD

Failure to follow the steps outlined below for each appliance connected to the venting system being placed into operation could result in carbon monoxide poisoning or death.

The following steps shall be followed for each appliance connected to the venting system being placed into operation, while all other appliances connected to the venting system are not in operation:

- 1) Seal any unused openings in the venting system.
- 2) Inspect the venting system for proper size and horizontal pitch, as required in the National Fuel Gas Code, ANSI Z223.1/NFPA 54 or the Natural Gas and Propane Installation Code, CSA B149.1 and these instructions. Determine that there is no blockage or restriction, leakage, corrosion and other deficiencies which could cause an unsafe condition.
- 3) As far as practical, close all building doors and windows and all doors between the space in which the appliance(s) connected to the venting system are located and other spaces of the building.
- 4) Close fireplace dampers.
- 5) Turn on clothes dryers and any appliance not connected to the venting system. Turn on any exhaust fans, such as range hoods and bathroom exhausts, so they are operating at maximum speed. Do not operate a summer exhaust fan.
- 6) Follow the lighting instructions. Place the appliance being inspected into operation. Adjust the thermostat so appliance is operating continuously.
- 7) Test for spillage from draft hood equipped appliances at the draft hood relief opening after 5 minutes of main burner operation. Use the flame of a match or candle.
- 8) If improper venting is observed during any of the above tests, the venting system must be corrected in accordance with the National Fuel Gas Code, ANSI Z223.1/NFPA 54 and/or Natural Gas and Propane Installation Code, CSA B149.1.
- 9) After it has been determined that each appliance connected to the venting system properly vents when tested as outlined above, return doors, windows, exhaust fans, fireplace dampers and any other gas-fired burning appliance to their previous conditions of use.

INTRODUCTION

KEEP THESE INSTRUCTIONS FOR FUTURE REFERENCE

All furnaces require a supply of oxygen for combustion. To assure this furnace receives the necessary oxygen, two free air openings of at least one square inch for each 1,000 Btu/hr. input rating of the furnace must be provided in the foundation of the house (see figure 1). Be sure these openings are located where the air can flow to the furnace and is not likely to be blocked.

This furnace is equipped with a temperature limit control that limits the register temperature under normal conditions of operations. This control may be overridden under unusual circumstances, such as extremely cold weather, to allow more heater output from this heater. A complete explanation of the operation of this control is contained in the "Operating Your Furnace" section of these instructions.

An inspection of the furnace and attached systems should be performed at least once each year by a qualified service technician. More frequent inspections are advisable if the furnace is installed or operated in a manner that might cause the accumulation of dust or dirt in the furnace or the failure of component parts more rapidly than would normally be expected. Keep all combustible materials, gasoline and other flammable liquids or vapors away from this furnace, and be sure that combustion and ventilation air openings supplying this furnace are kept clear at all times.

Continued safe and satisfactory performance of this furnace requires, but is not limited to, periodic examination of the vent system, pilot flame, combustion chamber, liners and gas supply lines and periodic cleaning of the burner air intake, pilot and control areas. The venting system, including the factory provided draft hood and all other parts of the vent, must be inspected periodically for indications of failure, such as loose joints, rusting components or broken parts. Any defective or damaged part, which does not provide a continuous conduit to carry the combustion products to the outside, must be replaced before the furnace is operated. A complete description of the venting requirements is contained in the "Venting and Chimney Requirements" section of these instructions.

This furnace is designed to burn only the type of gas that is indicated on the rating plate, visible on the bracket directly beneath the floor grille. Do not attempt to use this furnace with any other type gas. If you are not sure what type gas is available in your locality, obtain this information from your local gas supply company.

The pilot and control system of this furnace will automatically stop the gas flow to the pilot burner and main burner if the pilot flame is extinguished. This system also generates the electricity required to operate the thermostat system. Since no electrical power is required from any other source, this furnace will continue to operate during a power outage.

FIGURE 1 - AIR OPENINGS

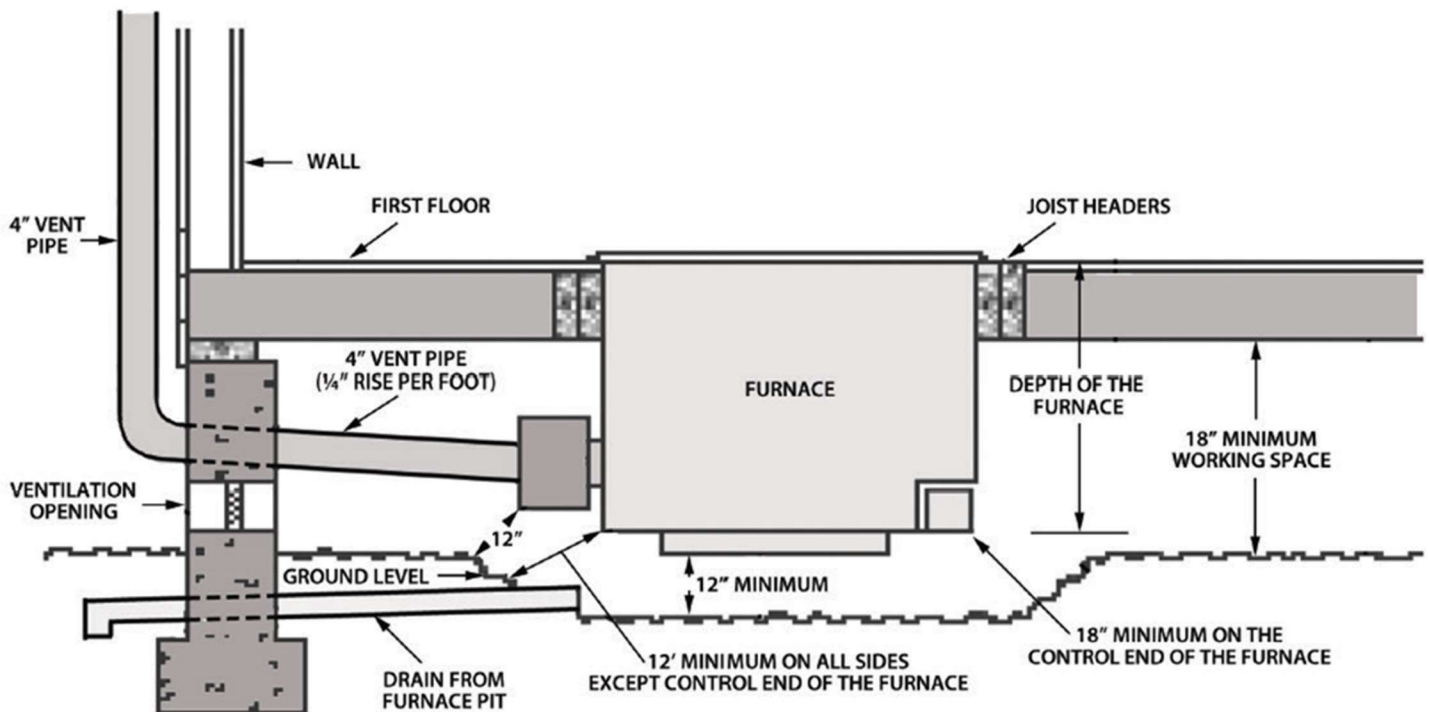

INSTALLING YOUR FURNACE

Locating the Furnace

Consider the following points before attempting to install the furnace:

1. To achieve the best results from this furnace, it must be located in an area that will provide good circulation of air to adjacent areas that need to be heated.
2. Warm air will rise from the furnace and travel to other areas only through open doorways, and that air must return to the furnace to be reheated.
3. In small homes, one unit centrally located may be sufficient to meet the heating requirements, but it is impractical to attempt to use this furnace where heat must travel through more than one doorway before reaching an area where heat is desired. A typical installation of a single unit in a small home is shown by **Figure 2**.
4. In larger homes, it may be necessary to use two or more units to provide sufficient heat distribution. It is often better to use two small furnaces rather than one large one.
5. If there is a difference in the floor level between two rooms to be heated, the furnace should be located in a room with the lower floor.
6. The flow of heat to various areas within the home can be effectively regulated by the opening and closing of doors.

CLEARANCES

1. Minimum clearance between the floor furnace and adjacent walls - 6".
2. Minimum clearance between furnace and doors, draperies or other combustible materials within the home - 12".
3. Minimum space required along two sides of the furnace to allow persons to walk around the furnace - 15".

The thermostat (optional) should be located on an interior wall far enough away from the furnace to prevent it from being heated directly by the furnace. Select a location in the area most frequently used or best situated to control the temperature of the entire house. Avoid locations where the thermostat might be subjected to drafts from windows, doors, stairways, etc., or from other devices such as cooking ranges, fireplaces, television, etc. Place the thermostat about five (5) feet above the floor. Do not select a location that will require more than 25 feet of wire between the furnace and the thermostat. Do not install the thermostat in an area which can be isolated from the furnace by a door.

LOCATION NOTE: Replacement floor furnaces of the same or lesser Btu/hr. input rating may be installed in the same location as the replaced furnace when such replacement does not create an unsafe condition.

After you have selected a location that will provide the necessary clearances and air circulation, check beneath the house to be sure that the clearances between the furnace and the ground, as specified by **Page 6, Figure 1**, can be obtained. It is permissible to dig a shallow pit, as shown in **Figure 1**, but a pipe or trench should be provided to drain away any water that may seep into the pit. If the depth of the pit must exceed 12", or if water is likely, a watertight pit of galvanized steel, copper, concrete or other suitable material should be constructed and anchored into place to prevent it from floating. The sides of this pan should extend four inches above the ground. The clearances between the upper rim of the pan and the furnace should be no less than those specified in **Figure 1**.

The width, length and depth of each furnace model is shown in **Page 10, Figure 6**.

FIGURE 2 - CENTRALLY LOCATED FURNACE

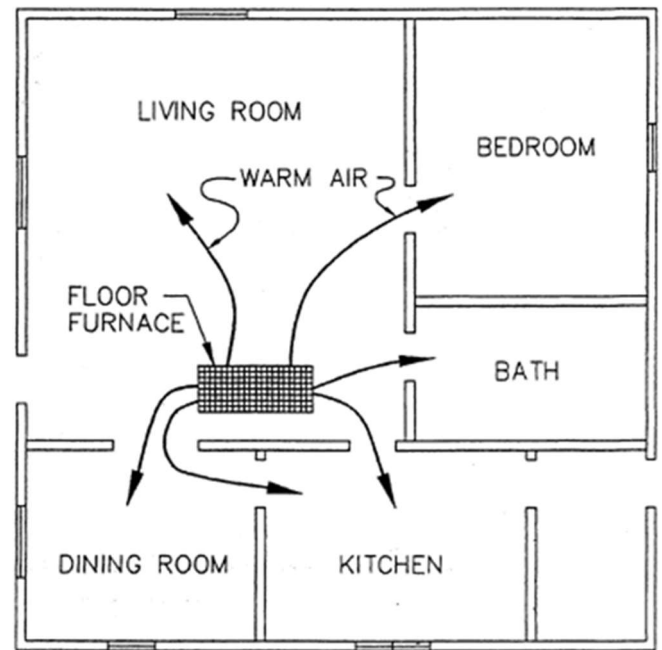

INSTALLING YOUR FURNACE

Venting and Chimney Requirements

Proper venting of this furnace is required to prevent the release of hazardous gases into the dwelling. The furnace must always be vented into a vertical vent. This vent may be a listed type "B" gas vent or lined masonry chimney. The following statements are intended as a guide for venting the furnace. If other venting requirements are required by local codes, the local codes must be adhered to.

If the furnace is to be vented into a masonry chimney, be sure the chimney is lined, clean and in good repair. Be sure the vent system is installed by a qualified installer and -

1. Do not connect this furnace to a chimney flue serving a separate solid fuel (coal or wood) burning appliance. Soot and creosote deposits from the solid fuel heating appliance can block the vent serving this furnace.
2. If this furnace is to be connected to a chimney that has previously been used for a solid fuel appliance, clean the chimney thoroughly of all deposits that might drop down and block the furnace vent.
3. The total length of the horizontal run of vent connector pipe must not exceed 75 percent of the height of the gas vent or chimney above the point where the vent connector is attached. All venting material must be supported by hangers spaced a maximum of four (4) feet apart and attached to the floor joist or by other methods approved by local codes.
4. The horizontal vent connector must be not less than 4 inches in diameter.
5. The horizontal vent connector must slope upward from the furnace to the chimney at least 1/4 inch per foot of connector length.
6. Avoid using a vent or chimney for more than one furnace if it is practical, but if it is necessary to use one vent for two furnaces, be sure the vent or chimney has an interior liner at least 6 inches in diameter.
7. If two furnaces are connected to a chimney or vent with a common vent connector, join the unit connectors as shown in **Figure 3**. Do not join the vent connectors with a tee. Be sure to size the vent connectors as shown in **Figure 3**.
8. Use a thimble when attaching the vent connector to a lined masonry chimney, and place the thimble at least 6 inches above the bottom of the chimney. Seal the vent connector and thimble joint to prevent gases from escaping.
9. Keep the vent connector at least 6 inches from all combustible material and if the vent connector must pass through a partition constructed of combustible materials, use a thimble in the partition that has been listed for this use by a nationally recognized testing agency. An improperly installed vent connector can overheat adjacent materials and cause a dangerous fire.
10. Be sure that there are no unsealed openings in the vent or chimney that will decrease the chimney draft and the chimney is at least 2 feet higher than all parts

of the building within 10 feet. This is required to reduce the possibility of wind interfering with the draft see **Figure 4**.

11. If the furnace is to be vented into a masonry chimney, be sure the chimney is lined, clean and in good repair.
12. Never terminate a vent pipe inside an attic, under the building, in a closet or with a horizontal run of vent pipe. The vent pipe must extend above the roof of the building as shown in **Figure 4**.
13. Do not use an uninsulated vent pipe. An uninsulated vent pipe can cause a fire hazard by overheating adjacent combustible materials. An uninsulated vent pipe can also cause condensation of the vent gases within the pipe and retard the draft.

FIGURE 3 - UNIT CONNECTOR

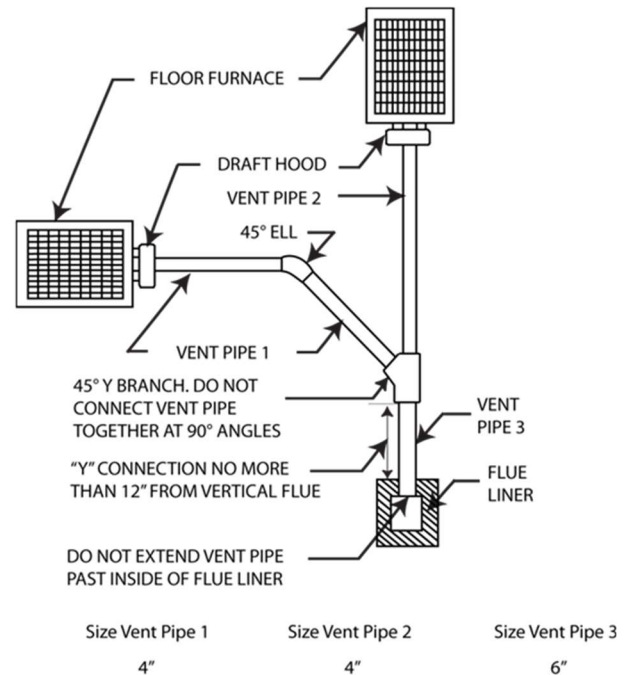
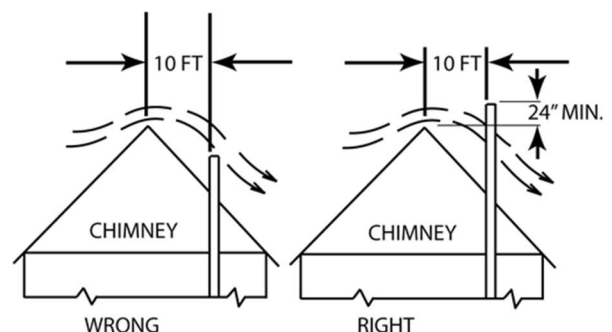

FIGURE 4 - CHIMNEY HEIGHT



Gas Supply and Piping Requirements

Gas pipe must be installed by a qualified installer. The pipe system must comply with the latest edition of the American National Fuel Gas Code 2223.1. Figure 5 depicts the required pipe arrangement at the furnace. The drip leg is required to prevent condensate and scale particles from entering the furnace controls. The union is required to allow the control to be removed for servicing. All unions in gas pipe systems shall be of the ground joint type. Use a pipe joint compound that is resistant to propane gas. Do not locate pipe joints in a concealed location where leak detection and repairs are difficult or impossible.

The maximum inlet supply pressure for this furnace must be 7 inches for natural gas and 13 inches for propane gas. The minimum inlet supply pressure for the purpose of input adjustment must be 5 inches for natural gas and 11 inches for propane gas. The control on this furnace is equipped with a regulator which reduces the manifold pressure to 4.0 inches for natural gas and 10.0 inches for propane gas.

If the furnace is equipped for propane gas, the gas tank must be provided with a regulator which will reduce the line pressure to the furnace to between 11 and 13 inches water column. Unregulated propane gas pressure will damage the control and cause it to leak hazardously.

CAUTION: The furnace and its individual shutoff valve must be disconnected from the gas supply piping system during pressure testing of that system at test pressures in excess of 1/2 psi. The furnace must be isolated from the gas supply piping system by closing its individual manual shutoff valve during any pressure testing of the gas supply piping system at test pressures equal to or less than 1/2 psi. Pressures in excess of 1/2 psi will cause damage to the control valve and may cause damage to the shutoff valve.

UNPACKING AND INSPECTION
Remove the furnace from the carton and inspect carefully for shipping and handling damage or missing parts. Report any damage or missing parts to your Williams dealer and be sure all problems are resolved before installing the furnace.

⚠ WARNING: DO NOT INSTALL A DAMAGED FURNACE. A furnace that is damaged or in poor repair can be hazardous.

FIGURE 5 - FURNACE TO GAS SUPPLY LINE CONNECTION

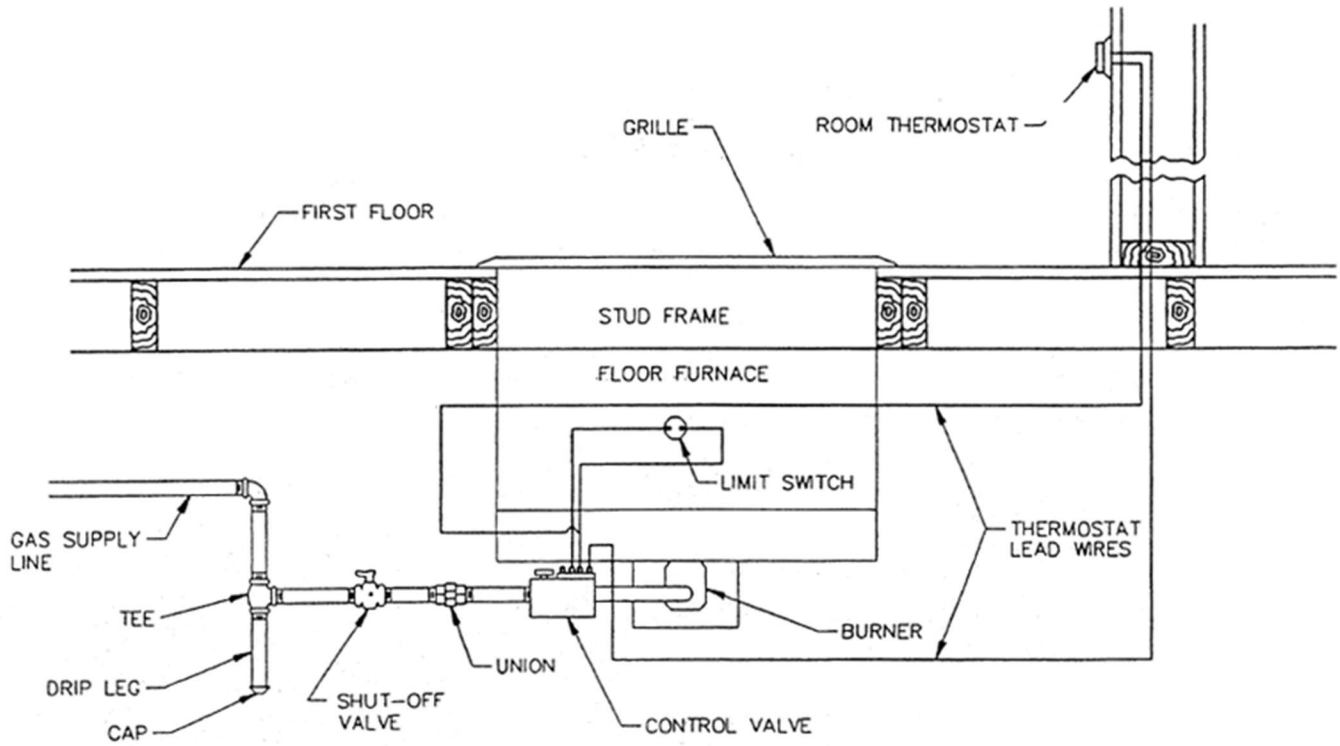

INSTALLING YOUR FURNACE

INSTALLATION

1. Lay an outline of the furnace in the selected location, and draw diagonally from each corner of the outline as shown in **Figure 6**.
2. Drive a nail through the flooring at the intersection of the diagonal lines.
3. Use the nail location as a reference, and examine the area beneath the floor to assure there are no obstructions that will prevent the installation of the furnace and that adequate clearance between the furnace and the ground can be obtained. If the selected location of the furnace is appropriate, **proceed to step 4**.
4. Bore two 1" diameter holes in opposite corners of the furnace outline. Be sure the holes do not extend beyond the furnace outline.
5. Insert a compass or sabre saw into one of the 1" diameter holes and cut along the furnace outline. Cut as straight and accurately as possible to avoid any possibility the hole will not fit the furnace or will extend beyond the outer perimeter of the furnace grille after it is installed.
6. If it is necessary to cut floor joists to install the furnace, install headers across the cut ends of the floor joists, and double the floor joists along each side of the furnace cut-out as shown in **Page 11, Figure 7**. If you must cut a girder or beam, construct an adequate foundation and pillar to support each end of the cut member.
7. If necessary, dig a pit and install a pan in the ground beneath the furnace to provide the required clearances.
8. Remove the grille from the furnace.
9. Lower the furnace into the floor opening until the flanges on the furnace cabinet rest on the floor.
10. Fasten the furnace in place by driving nails through the sides of the furnace cabinet and into the floor joists.
11. Refer to **Page 12, Figure 10** for the installation of draft hood collars and the draft hood.
12. Install the (2) draft hood collars and gaskets by positioning the collars into the (2) rectangular openings on the furnace, making sure gaskets are facing toward the furnace.
13. Slip the (2) draft hood collars over the combustion chamber outlets and engage the collars into the furnace until the gaskets press tight against the furnace. Secure the collars to the furnace with (12) screws previously removed.
14. Check to be sure that the draft hood collars fit snugly over the combustion chamber outlets.
15. Install the draft hood by positioning the draft hood with the open side down. Slip it over the draft hood collars making sure the draft hood collars engage into the draft hood. Secure the draft hood to the furnace with (4) screws previously removed.
16. Install the pipe necessary to connect the furnace to the gas vent or chimney. Be sure to comply with all the requirements for proper venting as stated in the "Venting and Chimney Requirements" section of this manual.
17. Connect the furnace to the gas supply line as specified by the "Gas Supply and Piping Requirements" section of this manual, **see Page 9, Figure 5**.
18. Install the thermostat and connect the thermostat lead wires to the limit switch and control as shown in **Page 11, Figure 8**.
19. Use Williams thermostat P322016 (sold separately) or any millivolt thermostat.

FIGURE 6 - MARKING FOR FURNACE INSTALLATION

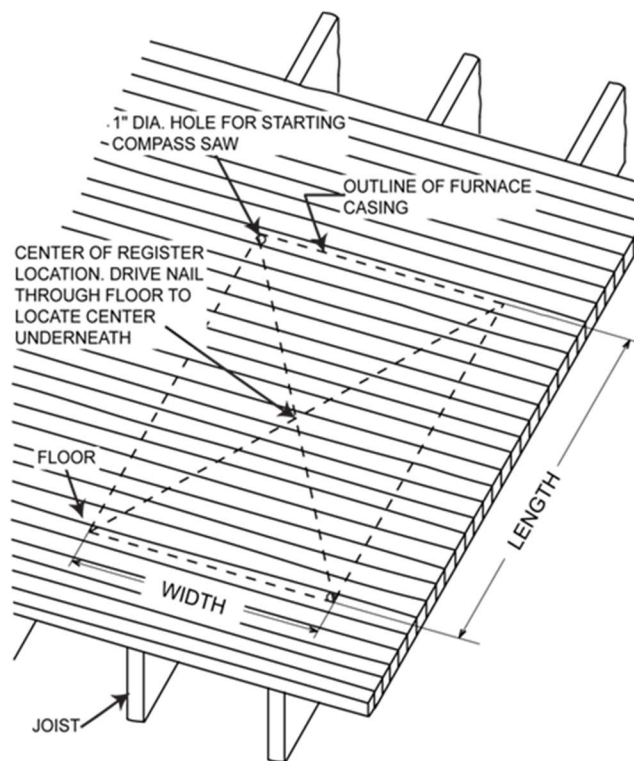

<u>MODEL NUMBER</u>	<u>WIDTH</u>	<u>LENGTH</u>	<u>DEPTH</u>
4505621A; 4505622A	24-1/4	32-3/8	28
6005621A; 6005622A	24-1/4	42-3/8	28

- Turn on the gas and check all gas fittings for leaks with a soapy water solution or a liquid leak detection solution. **DO NOT USE A FLAME TO CHECK FOR LEAKS.**

⚠ WARNING: The use of a flame for leak detection can cause a dangerous explosion.

- Refer to the "Lighting and Operation" section of this manual. Carefully read the safety information, and then light the pilot and the main burner according to the instructions. Allow the main burner to burn for five minutes, see **Page 12, Figure 11** for typical burner flame pattern.
- Check the vent or chimney performance by holding a match near the edge of the draft hood as shown in **Page 12, Figure 12**. If the flame is not pulled into the draft hood, the chimney is not providing sufficient draft. This can allow hazardous gases to escape the vent system. Find and correct the causes of this malfunction.
- Replace the grille on top of the furnace. The small clip attached to the chain at the limit switch box should be hung over a section of the grille so it can be used to override the limit switch as described in the "Operating the Furnace" section of this manual. Explain the operation of the furnace to the homeowner and give these instructions to the homeowner.

FIGURE 7

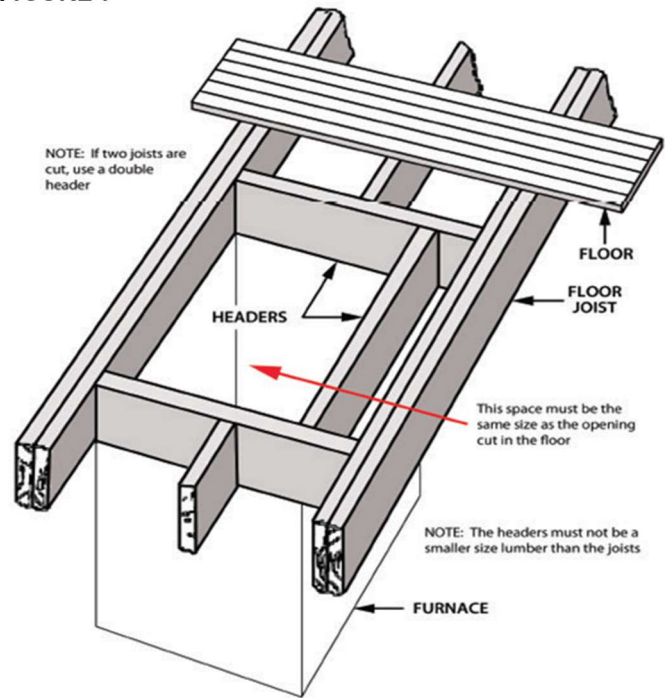
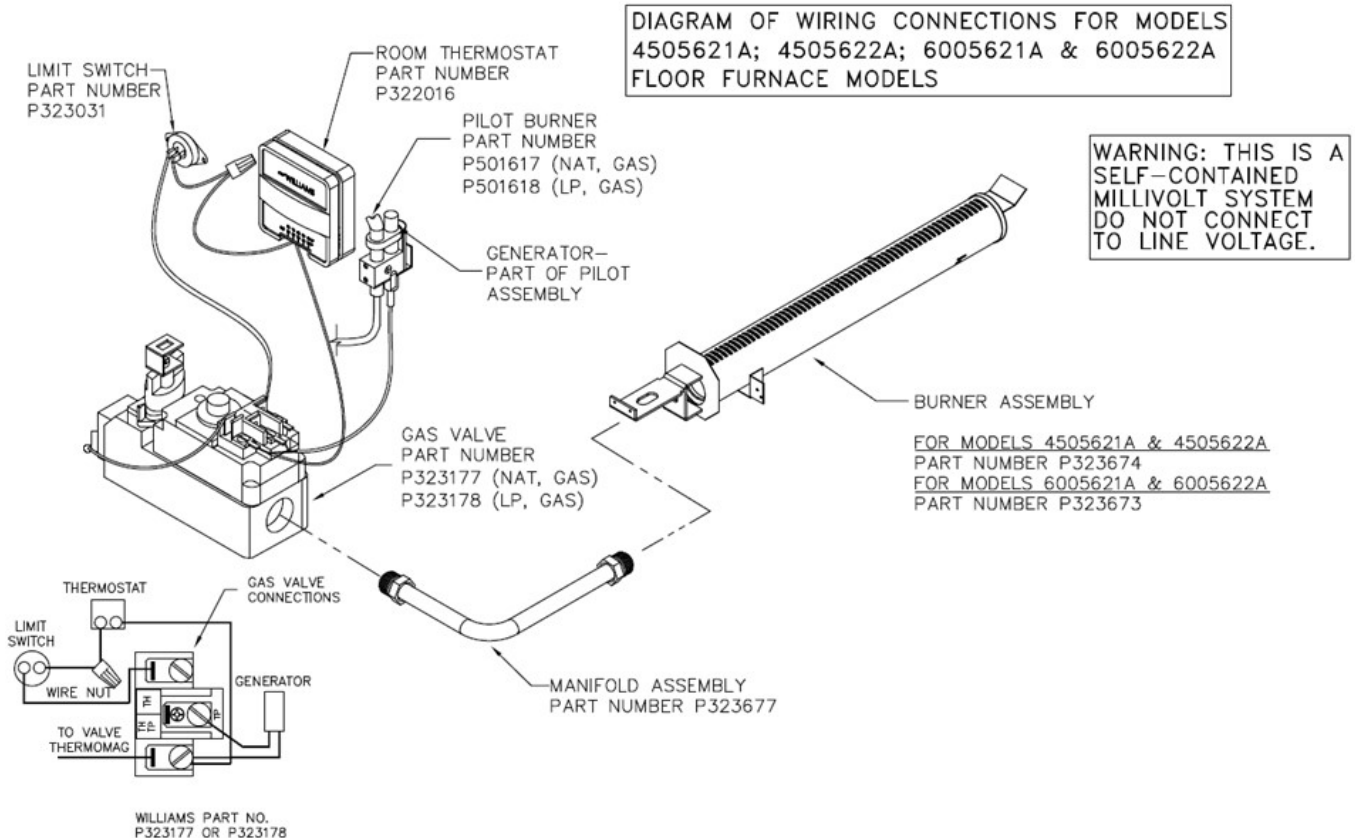

FIGURE 8 - THERMOSTAT CONNECTIONS



INSTALLING YOUR FURNACE

FIGURE 9 - FLAME ADJUSTMENT

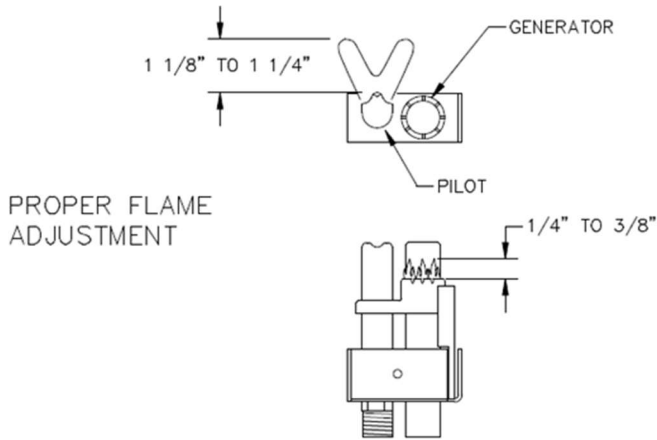

FIGURE 12 - PERFORMANCE CHECK

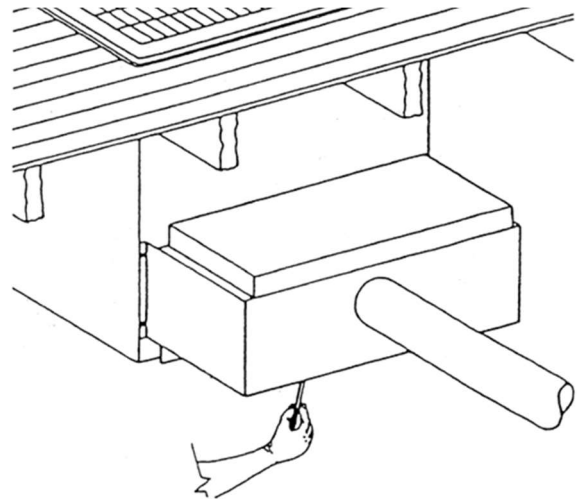
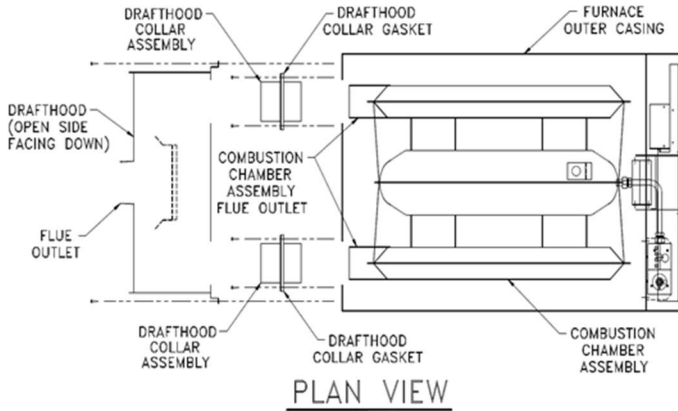

FIGURE 10 - INSTALLATION OF DRAFT HOOD



Start-Up Procedure

Start the furnace using the procedures in the section "Operating Your Furnace".

⚠ WARNING: Danger of bodily injury or death. propane gas is heavier than air and it will settle in any low area, including open depressions and it will remain there unless the area is ventilated. Never attempt to start-up the unit before thoroughly ventilating the area.

Check the furnace operation as outlined in the following instructions.

FIGURE 11 - FLAME PATTERN

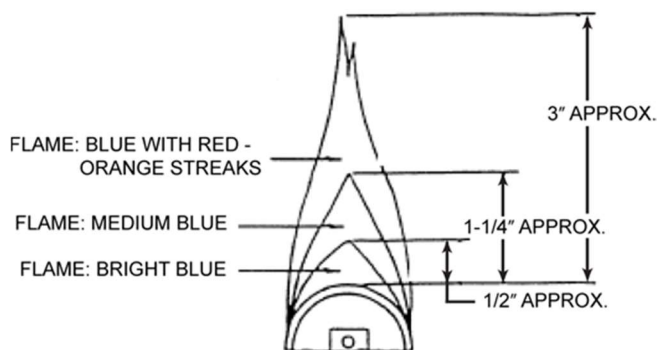

CHECK GAS INPUT AND PRESSURES

For furnaces located at elevations between sea level and 2,000 feet, the measured input must not be greater than the input shown on the rating plate of the furnace. For elevations above 2,000 feet, the measured input must not exceed the input on the rating plate reduced by 4 percent for each 1,000 feet that the furnace is above sea level.

Gas supply pressure and manifold pressure with the burners operating is specified on the rating plate.

Rated input will be obtained on a heating value of 2,500 BTU/hr. for propane at 10-inches manifold pressure with factory-sized orifices. If L.P. Gas having a different heating value is supplied, orifices must be changed by a qualified service technician before the furnace is operated.

TYPE OF GAS	MANIFOLD PRESSURE, IN. W.C.
NATURAL	4.0"
PROPANE	10.0"

OPERATING YOUR FURNACE

CHECK THERMOSTAT

Check the thermostat operation. When set above room temperature shown on the thermostat, the main burner should light. Make certain the thermostat turns off the furnace when the room temperature reaches the selected setting and starts the furnace when the room temperature falls a few degrees.

CHECK THE MANIFOLD GAS PRESSURE

A tapped opening is provided in the gas valve to facilitate measuring the manifold gas pressure. A "U Tube" manometer having a scale range from 0 to 12-inches of water should be used for this measurement. The manifold pressure must be measured with the burner and pilot operating. Any major changes in flow must be made by changing the size of the burner orifice.

Check with your local gas supplier for proper orifice sizing.

CHECK THE GAS INPUT (NATURAL GAS ONLY)

⚠ WARNING: Natural gas heating value (BTU per cubic foot) can vary significantly. Therefore, it is the installer's responsibility to see that Btu/hr. input to the furnace is adjusted properly. Failure to do so could cause combustion chamber failure, asphyxiation, fire or explosion resulting in damage, bodily injury or death. Refer to the National Fuel Gas Code (NFPA 54) to be sure the furnace is burning fuel at the proper rate.

Under firing could cause inadequate heat, excessive condensation or ignition problems. Over firing could cause sooting, flame impingement or overheating of the combustion chamber.

Before starting natural gas input check, obtain heating value of the gas (Btu per cubic foot) at standard conditions from your local supplier.

To measure the input, using the gas meter, proceed as follows:

1. Turn off gas supply to all other appliances except the furnace.
2. With the furnace operating, time the smallest dial on the meter for one complete revolution. If this is a 2-cubic-foot dial, use the time in seconds as is (3,600 = Sec/hr.). Divide the seconds by 2 if it is a 1-cubic-foot dial. This gives the seconds per cubic foot of gas being delivered to the furnace.
3. Assuming natural gas with a heating value of 1,000 Btu per cubic foot and 34-seconds per cubic foot used as determined by step (2), then:

$$\text{Input} = 1,000 \times 3,600 / 34 = 106,000 \text{ BTU/hr.}$$

This measured input must not be greater than the input indicated on the nameplate of the furnace.

4. Relight all other appliances turned off in Step 1 above. Be sure all pilots are operating.

FOR YOUR SAFETY, READ BEFORE LIGHTING

⚠ WARNING: If you do not follow these instructions exactly, a fire or explosion may result causing property damage, personal injury or loss of life.

- A. This appliance has a pilot which must be lighted by hand. When lighting the pilot, follow these Instructions exactly.
- B. **BEFORE LIGHTING** smell around the appliance area for gas. Be sure to smell next to the floor because some gas is heavier than air and will settle on the floor.

WHAT TO DO IF YOU SMELL GAS

- Do not try to light any appliance or strike a match.
 - Do not touch any electric switch; do not use any phone or cell phone in your building.
 - Immediately call your gas supplier from a neighbor's phone. Follow the gas supplier's instructions.
 - If you cannot reach your gas supplier, call the fire department.
- C. Use only your hand to push in or turn the gas control knob. Never use tools. If the knob will not push in or turn by hand, don't try to repair it, call a qualified service technician. Force or attempted repair may result in a fire or explosion.
 - D. Do not use this appliance if any part has been under water. Immediately call a qualified service technician to inspect the appliance and to replace any part of the control system and any gas control which has been under water.

⚠ WARNING: Floor furnace grilles are heated when the furnace is in operation. Direct skin contact with the grille can result in serious burns. Keep children away, install a fence or grille protector to protect them.

OPERATING INSTRUCTIONS

To turn OFF gas to appliance

1. **STOP!** Read the safety information above on this label.
2. Set the thermostat to the lowest setting.
3. With the key, depress the control rod slightly and turn the pointer clockwise to "OFF".



1. Set the thermostat to the lowest setting.
2. With the key, depress the control rod slightly and turn clockwise to "OFF".

Operating the Furnace

Always follow the instructions located beneath the furnace grille when lighting the pilot. To set the thermostat, turn the temperature selector to the highest setting until the heated area reaches the desired temperature, then move the selector slowly toward a lower setting until the furnace control cycles off the burner. At this setting, the furnace should cycle on and off as required to maintain the desired temperature.

WARNING: The surface of the furnace is hot during operation. Keep children, clothing, furniture and flammable material away from the furnace.

4. Wait five (5) minutes to clear out any gas, then smell for gas, including near the floor. **IF YOU SMELL GAS, STOP!** Follow "B" in the safety information above. If you don't smell gas, go to the next step.
5. Find the pilot through observation hole.

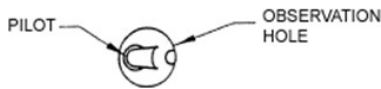

6. Turn knob on the gas control counterclockwise to "PILOT."

7. Position yourself so the pilot can be seen through the observation hole. Push the control rod down fully and hold it down. Immediately push the igniter button.

Push the igniter button continuously until the pilot is lit. After the pilot is lit, continue to hold the control rod down for about one (1) minute. Release the control rod and it will pop back up. The pilot should remain lit. If it goes out, repeat steps 2 through 7.

ALTERNATE LIGHTING WITH A MATCH: Follow steps 2 through 6. Remove cover from observation hole. Place a match in the lighter rod, ignite and lower to the pilot burner (through observation hole). Depress the control rod down fully and hold it down for about one (1) minute after the pilot lights. Release the control rod and it will pop back up. The pilot should remain lit. If it goes out, repeat steps 2 through 7. Replace the cover on the observation hole, making sure the gasket is in place.

If the pilot will not stay lit after several tries, depress the gas control rod slightly and turn to "OFF", and call your service technician or gas supplier.

If the control rod does not pop up when released, stop and immediately call your service technician.

8. Turn the gas control rod counterclockwise to "ON".
9. Set the thermostat to the desired setting.

This furnace is equipped with a control that limits the temperature of the furnace grille by cycling the main burner. This control may be overridden to allow more heat output from the furnace during extreme weather when the furnace will not provide sufficient heat otherwise. The override mechanism is located beneath the grille on the control end. To override the temperature limit control, pull up on the chain attached to the grille until the flap bearing the "Register Hot --" warning is in the horizontal position. Insert chain through slot to the side of the flap to hold flap in the horizontal position (see Figure 13). To reactivate the temperature limit control, remove chain from slot and the flap will hang down. Do not override the temperature limit control if the furnace is in an area occupied by children or elderly persons who could fall on the furnace and be burned.

FIGURE 13

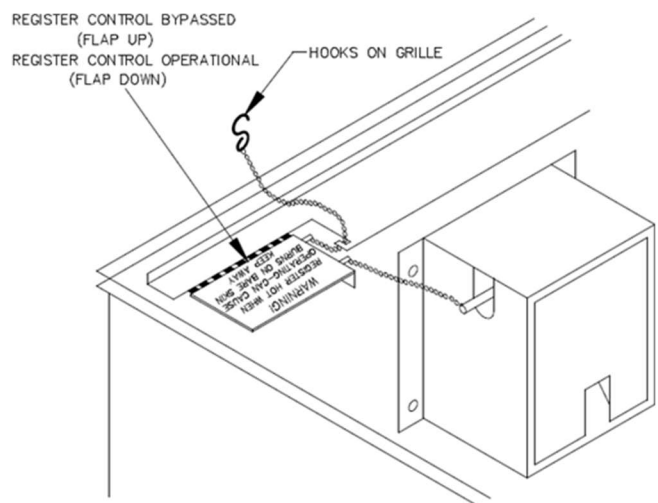

CARING FOR YOUR FURNACE

BURNER FLAME CHARACTERISTICS

Start the furnace and let it operate for at least 10 minutes. Open the access door to view the burner flame. Limit your movements near the furnace a few more minutes before making your final observation. The flame may look yellow due to dust particles in the room air. The flame should change to a nice blue color with firm inner and secondary cones. An occasional flash of orange might be seen as dust particles burn in the flame. This is normal. No burner adjustment is provided, or is necessary, for models equipped with round stainless steel burners.

NORMAL APPEARANCE

NATURAL GAS:

1. Inner cone - blue color - 3/8 to 5/8-inch above the ports.
2. Secondary inner cone - light blue - 1 to 2-inches above the ports.
3. Total flame - from blue to nearly invisible - approximately 6-inches above the ports.

PROPANE GAS:

1. Inner cone - blue color - 1/2 to 3/4-inch above the ports.
2. Secondary inner cone - light blue - 1 to 2-inches above the ports.
3. Total flame - from blue to nearly invisible - approximately 6-inches above the ports.

ABNORMAL APPEARANCE

LAZY FLAME:

Long soft yellow cones moving around in the combustion chamber lifting from the ports (insufficient air).

EXTREMELY FAST FLAME:

Flame will not hold to the ports - entire cone sections blow off from noisy ports (too much pressure).

WARNING: If the flame appears abnormal, contact the gas company or a qualified service technician immediately.

FIGURE 14

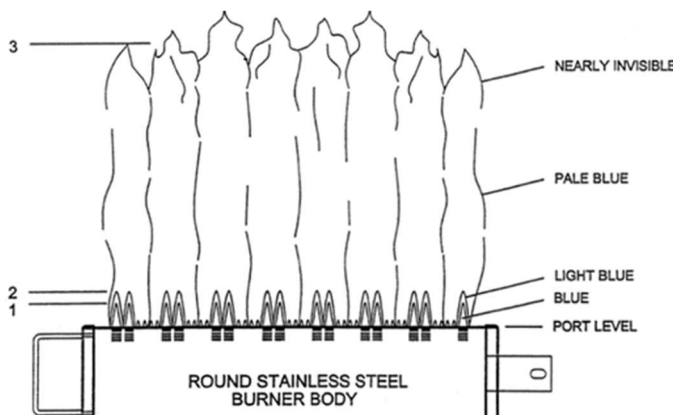

HOW TO CARE FOR YOUR FURNACE

Service, repair or maintenance of the furnace, vent or gas system should only be attempted by a qualified service technician.

The burner and control of the furnace should be cleaned and checked at least once each year by a qualified service technician. If there is any indication that the furnace is operating improperly, turn it off and have it checked immediately.

Lint and dust may be vacuumed from the interior of the furnace, when it is cool, by removing the floor grille. The control and main burner can be blown free of dust and lint with a vacuum cleaner.

WARNING: DO NOT STORE OR USE GASOLINE OR OTHER FLAMMABLE LIQUIDS OR VAPORS NEAR THE FURNACE.

If the combustion chamber must be removed for servicing -

1. Turn the gas off at the main gas line shut-off valve.
2. Remove the floor grille and lift out the inner casing.
3. Lift the control end of the combustion chamber slightly, slide the chamber toward the end of the cabinet about one inch and then lift it out of the cabinet.

WARNING: DANGER OF BODILY INJURY OR DEATH. DO NOT OPERATE THE FURNACE WITH A BROKEN OR MISSING PILOT OBSERVATION DOOR.

If the control and main burner assembly must be removed for servicing -

1. Turn the gas off at the main gas line shut-off valve.
2. Disconnect the union in the gas supply line.
3. Remove the thermostat control wires from the gas control.
4. Remove the nuts that attach the gas control to the furnace outer casing.
5. Remove the control assembly.
6. Remove the screw that attaches the control end of the burner to the outer casing.
7. Slide the burner forward until the control end of the burner can be dropped down and pull the burner out of the outer casing.

This should be done by a qualified service technician.

If the furnace will not be used for a long period of time, turn the control knob to the "OFF" position and turn off the shut off valve in the gas line serving the furnace.

GAS CONVERSION KITS	
NATURAL TO PROPANE GAS	
MODEL	DESCRIPTION
8953	450A SERIES
8954	600A SERIES
PROPANE TO NATURAL GAS	
8955	450A SERIES
8956	600A SERIES

FURNACE ACCESSORY REPLACEMENT PARTS 450 / 600 MODELS

MODEL NUMBERS					
		4505622A	4505621A	6005622A	6005621A
REF. NO.	REPLACEMENT PART DESCRIPTION	4505622A	4505621A	6005622A	6005621A
1	Grill Floor	P322428	P322428	P322429	P322429
2	Inner Liner Assembly	4B0041	4B0041	4B0042	4B0042
3	Combustion Chamber	8964	8964	8965	8965
4	Outer Shield Assembly	4B0036	4B0036	4B0069	4B0069
5	Peep Hole Cover Assembly	12B40	12B40	12B40	12B40
6	Igniter	P285500	P285500	P285500	P285500
7	Limit Switch	P323031	P323031	P323031	P323031
8	Control Key	P322445	P322445	P322445	P322445
9	Control Rod	4A0037	4A0037	4A0037	4A0037
10	Lighter Rod	P322431	P322431	P322431	P322431
11	Control Valve Natural	P323177	-	P323177	-
	Control Valve Propane	-	P323178	-	P323178
12	Valve Bracket	4B0087	4B0087	4B0087	4B0087
13	Manifold Assembly	P323677	P323677	P323677	P323677
14	Pilot Natural	P501617	-	P501617	-
	Pilot Propane	-	P501618	-	P501618
15	Shield Burner	4B0014	4B0014	4B0010	4B0010
16	Burner	P323674	P323674	P323673	P323673
17	Gasket Flue Outlet	P322439	P322439	P322439	P322439
18	Drafhod Collar Assembly	4B80072	4B80072	4B0072	4B0072
19	Drathood Assembly	4B0026	4B0026	4B0026	4B0026
20	Envelope Assembly	4A0024	4A0024	4A0024	4A0024
Thermostat not included with these models.					

EXPLODED VIEW & REPLACEMENT PARTS

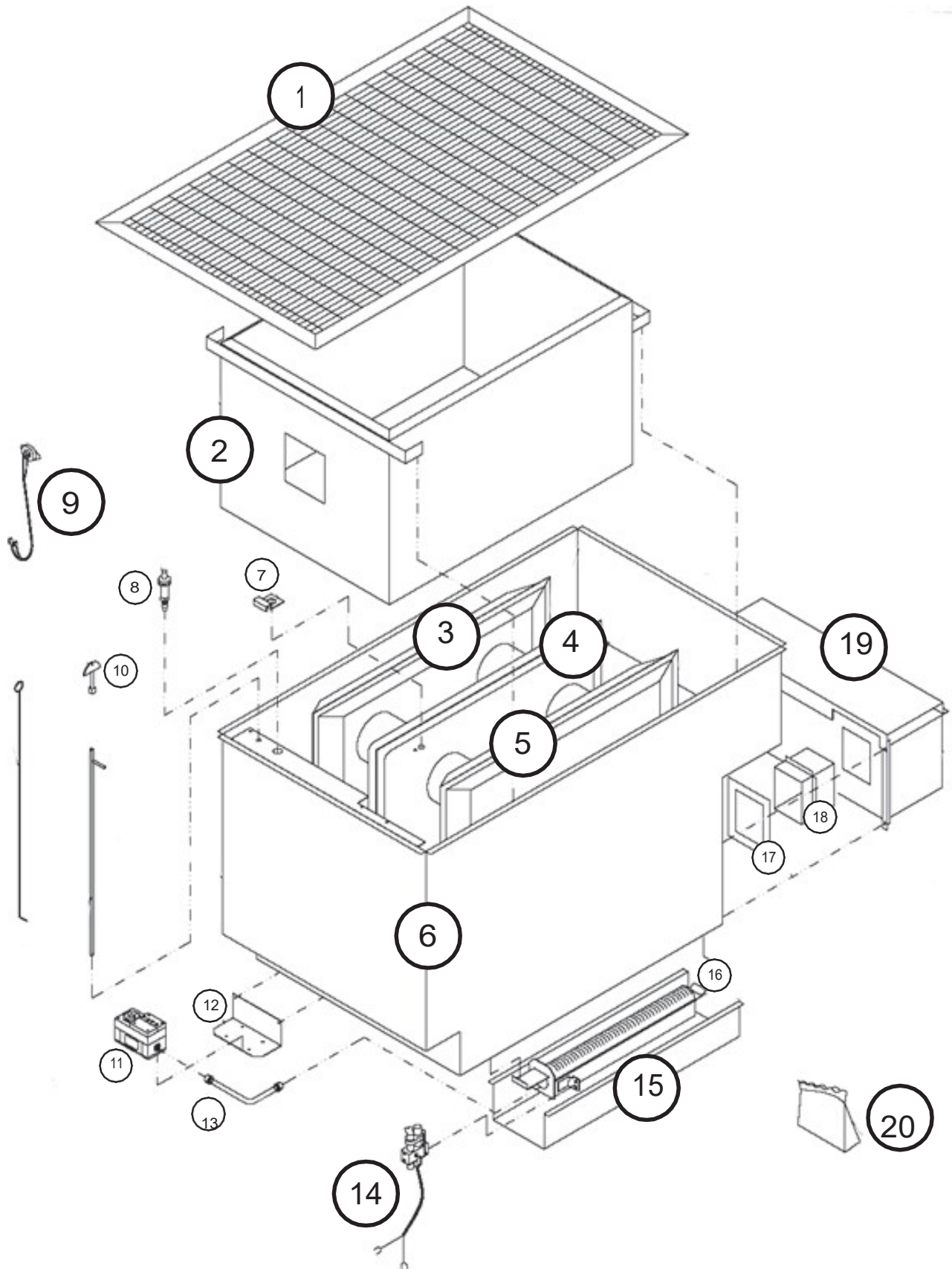

TROUBLESHOOTING YOUR FURNACE

For qualified service technicians.

ISSUE	POSSIBLE CAUSE(S)	CORRECTIVE ACTION
1. Flame too large.	A. Pressure regulator set too high. B. Defective regulator. C. Burner orifice too large.	Reset, using manometer. Replace. Replace with correct size.
2. Noisy flame.	A. Too much primary air. B. Noisy pilot. C. Burr in orifice.	See Item 1. Reduce pilot gas. Remove burr or replace.
3. Yellow tip flame.	A. Too little primary air B. Clogged burner ports. C. Misaligned orifices. D. Clogged draft hood.	Look for obstructions in air path. Clean ports. Realign or replace burner. Clean.
4. Floating flame.	A. Blocked venting. B. Insufficient primary air.	Clean. Look for obstructions in air path.
5. Delayed ignition.	A. Improper pilot location. B. Pilot flame too small. C. Burner ports clogged. D. Low pressure.	Reposition pilot. Check orifice, increase gas. Clean ports. Adjust pressure regulator.
6. Failure to ignite.	A. Main gas off B. Defect in gas valve. C. Defective thermostat.	Open manual valve. Replace. Replace.
7. Burner won't turn off.	A. Poor thermostat location. B. Defective thermostat or wiring. C. Defective control valve.	Relocate thermostat. Replace or repair. Clean or replace.
8. Rapid burner cycling.	A. Poor thermostat location. B. Defective thermostat.	Relocate. Replace.
9. Burner won't turn on.	A. Defective control valve. B. Defective thermocouple. C. Defective thermostat. D. Defective limit switch.	Replace. Replace. Repair or replace. Replace.
10. Not enough heat.	A. Thermostat set too low. B. Appliance close to thermostat. C. Thermostat in bad location. D. Thermostat out of calibration.	Raise setting. Move heat source away. Relocate thermostat. Recalibrate or replace.
11. Too much heat.	A. Thermostat set too high. B. Thermostat out of calibration. C. Valve sticks open. D. Thermostat in draft.	Lower setting. Recalibrate or replace. Replace valve. Relocate thermostat.

HINTS AND INFORMATION

If your furnace fails to work correctly, you may avoid the inconvenience and cost of a service call by checking the troubleshooting section on **page 18** before you call for service.

 **WARNING:** If the information in this manual is not followed exactly, a fire or explosion may result causing property damage, personal injury or loss of life.

DO NOT store or use gasoline or other flammable vapors and liquids in the vicinity of this or any other appliance.

HOW TO ORDER REPAIR PARTS

When ordering repair parts, always give the following information:

1. MODEL NUMBER
2. MFG. DATE CODE
3. PART NUMBER
4. PART DESCRIPTION

All parts listed herein may be ordered from your equipment supplier. The Model Number of your Williams wall furnace will be found on the nameplate near gas valve, inside control compartment.

WHAT TO DO IF YOU SMELL GAS

- Open all of the windows.
- Do not try to light any appliance.
- Do not touch any electrical switch.
- Do not use any phone or cell phone in your building.
- Extinguish any open flame.
- Immediately call your gas supplier from a neighbor's phone. If you cannot reach your gas supplier, call the fire department.

Installation and service must be performed by a qualified installer, service agency or the gas supplier.

TM

