

# OWNER'S MANUAL

## INSTALLATION INSTRUCTIONS

### FORSAIRE COUNTERFLOW DIRECT-VENT GAS WALL FURNACES

**MODELS:**

4007332; 4007732; 5507332; 6007732  
FOR USE WITH NATURAL GAS ONLY

**MODELS:**

4007331; 4007731; 5507331; 6007731  
FOR USE WITH PROPANE GAS ONLY

READ THIS OWNER'S MANUAL CAREFULLY BEFORE YOU  
INSTALL YOUR NEW WILLIAMS WALL FURNACE.

SAVE THIS MANUAL FOR FUTURE REFERENCE.



**WARNING:** This direct-vent furnace is approved for aftermarket manufactured home installations (once the manufactured home is sold, installed and stationary) unless prohibited by local codes. Not for manufactured home manufacturer (factory) installation. Do not install any of these furnaces (natural or L.P. Gas) in trailers or recreational vehicles.

**WARNING:** This product can expose you to chemicals including epichlorohydrin which is known to the State of California to cause cancer and birth defects and/or other reproductive harm. For more information go to [www.p65warnings.ca.gov](http://www.p65warnings.ca.gov).

**WARNING:** Improper installation, adjustment, alteration, service or maintenance can cause injury or property damage. Refer to this manual for proper installation. For assistance or for additional information consult a qualified installer, service agency or the gas supplier.

**WARNING:** If the information in these instructions is not followed exactly, a fire or explosion may result causing property damage, personal injury or loss of life.

- Do not store or use gasoline or other flammable vapors and liquids in the vicinity of this or any other appliance.
- **WHAT TO DO IF YOU SMELL GAS:**
  - Open all windows.
  - Do not try to light any appliance.
  - Do not touch any electrical switch; do not use any phone or cell phone in your building.
  - Extinguish any open flame.
  - Immediately call your gas supplier from a neighbor's phone. Follow the gas supplier's instructions.
  - If you cannot reach the gas supplier, call the fire department.
- Installation and service must be performed by a qualified installer, service agency or the gas supplier.

# Warranty

The manufacturer, Williams Comfort Products, warrants this wall furnace or heater to the original purchaser under the following conditions:

## LIMITED ONE-YEAR WARRANTY

1. Any part thereof which proves to be defective in material or workmanship within one year from date of original purchase for use will be replaced at the Manufacturer's option, FOB to its factory.
2. No liability is assumed by the Manufacturer for removal or installation labor costs, nor for freight or delivery charges.

## LIMITED EXTENDED WARRANTY

1. In addition to the above limited one-year warranty on the complete unit, any combustion chamber which burns out or rusts under normal installation, use and service conditions during a period of nine years following expiration of the one-year warranty period will be exchanged for a like or functionally similar part.
2. No liability is assumed by the Manufacturer for removal or installation labor costs, nor for freight or delivery charges.

## LIMITATIONS

1. THIS LIMITED WARRANTY IS THE ONLY WARRANTY MADE BY THE MANUFACTURER, IMPLIED WARRANTIES OF MERCHANTABILITY OR FITNESS FOR ANY PARTICULAR PURPOSE ARE LIMITED TO THE SAME ONE YEAR TERM AS THE EXPRESS WARRANTY. UNDER NO CIRCUMSTANCES SHALL THE MANUFACTURER BE LIABLE FOR INCIDENTAL, CONSEQUENTIAL, SPECIAL OR CONTINGENT DAMAGES OR EXPENSES ARISING DIRECTLY OR INDIRECTLY FROM ANY DEFECT IN THE PRODUCT OR ANY COMPONENT OR FROM THE USE THEREOF. THE REMEDIES SET FORTH HEREIN ARE THE EXCLUSIVE REMEDIES AVAILABLE TO THE USER AND ARE IN LIEU OF ALL OTHER REMEDIES.

Some states do not allow limitation on how long an implied warranty lasts, and some states do not allow the exclusion or limitation of incidental or consequential damages, so the above limitations or exclusions may not apply to you.

2. This warranty does not include any charge for labor or installation.
3. This warranty does not extend to painted surfaces or to damage or defects resulting from accident, alteration, misuses or abuse or improper installation.
4. This warranty does not cover claims which do not involve defective workmanship or materials.

## DUTIES OF THE CONSUMER

1. The heating equipment must be installed by a qualified installer and operated in accordance with the installation and homeowner's instructions furnished with the equipment.
2. Any travel, diagnostic costs, service labor, and labor to repair the defective unit will be the responsibility of the owner.
3. A bill of sale, cancelled check, payment record or permit should be kept to verify purchase date to establish the warranty period.
4. Have the installer enter the requested information in the space below.

## GENERAL

1. The manufacturer neither assumes nor authorizes any person to assume for it any other obligation or liability in connection with said equipment.
2. Service under this warranty should be obtained by contacting your dealer. Provide the dealer with the model number, serial number, and purchase date verification.
3. If, within a reasonable time after contacting your dealer, satisfactory service has not been received, contact: Customer Service Department, 250 West Laurel Street, Colton, CA 92324 for assistance.
4. THIS WARRANTY GIVES YOU SPECIFIC LEGAL RIGHTS AND YOU MAY ALSO HAVE OTHER RIGHTS WHICH VARY FROM STATE TO STATE.

# Installation Record

Model No. \_\_\_\_\_ Serial No. \_\_\_\_\_

Original Purchaser \_\_\_\_\_

Address \_\_\_\_\_

City and State \_\_\_\_\_ Zip \_\_\_\_\_

Dealer \_\_\_\_\_

Address \_\_\_\_\_

City and State \_\_\_\_\_ Zip \_\_\_\_\_

Installation Date \_\_\_\_\_ Name \_\_\_\_\_ Signature \_\_\_\_\_

(Dealer or authorized representative who certifies that this appliance is installed in accordance with Manufacturer's instructions and local codes.)

# Contents

Your Williams Warranty .....	2	Quick Reference: Here's how to...	
Installation Record.....	2	Unpack the furnace.....	6
Table of Contents .....	3	Learn how to unpack the new Williams Furnace and verify that all its parts are in working order.	
Safety Rules .....	4	Install the furnace.....	7-20
Introduction.....	5-6	Recessed Mount, Surface Mount, Thermostat and Vent Installation is all explained starting on page 9.	
Basic Description.....	5	Operate the furnace .....	22-27
Basic Tools Needed .....	5	Igniting the furnace for the first time.	
Basic Materials Needed.....	5	Caring for Your Furnace .....	28-29
Optional Accessories.....	6	Learn how to keep your new Williams Furnace operating.	
Unpack Your Furnace .....	6		
Installing Your Wall Furnace.....	7		
Locating Wall Furnace and Thermostat.....	7-8		
Recessed Mount Installation .....	9-10		
Surface Mount Installation .....	11-12		
Thermostat Installation.....	13		
Vent Installation .....	14-16		
Mounting Your Furnace .....	16-17		
Gas Supply and Piping .....	18-19		
Electrical Wiring.....	19-20		
Start Up Procedure.....	21		
Operating Your Furnace .....	22-27		
How To Care For Your Furnace .....	28-29		
Furnace Technical Information .....	29		
Wiring Diagrams .....	30-31		
Repair Parts 4007332, 4007732, 4007331 & 4007731.....	32-33		
Parts List for 4007332, 4007732, 4007331 & 4007731 .....	34-35		
Repair Parts 5507332, 6007732, 5507331 & 6007731.....	36-38		
Parts List for 5507332, 6007732, 5507331 & 6007731 .....	39-41		
Installations in the State of Massachusetts.....	42		
Gas Conversion Kits.....	42		
Forsaire Hardwire Accessory - 9940 .....	43		
TRUBLESHOOTING CHART .....	44-47		
SERVICE HINTS.....	Back Cover		
How To Order Repair Parts .....	Back Cover		

# Safety Rules

**WARNING:** Read these rules and the instructions carefully. Failure to follow these rules and instructions could cause a malfunction of the furnace. This could result in death, serious bodily injury and/or property damage.

INSTALLATION MUST CONFORM TO LOCAL CODES. IN THE ABSENCE OF LOCAL CODES, INSTALLATION MUST CONFORM TO THE NATIONAL FUEL GAS CODE, ANSI Z223.1. THE APPLIANCE, WHEN INSTALLED MUST BE ELECTRICALLY CONNECTED AND GROUNDED IN ACCORDANCE WITH LOCAL CODES OR, IN THE ABSENCE OF LOCAL CODES, WITH THE CURRENT NATIONAL ELECTRICAL CODE ANSI/NFPA NO. 70.

## In Canada:

1. Installation must conform to local codes or, in the absence of local codes, the current CAN/CGA B149 installation code.
2. The appliance, when installed, must be electrically connected and grounded in accordance with local codes or, in the absence of local codes, with the current CSA C22.1 Canadian Electrical code.
3. Reference is made in this manual regarding gas type as L.P.G. Be advised that L.P.G. is not available in Canada, refer to Propane/L.P. Gas.

1. Use only manufacturer's replacement parts. Use of any other parts could cause injury or death.
2. DO NOT install the furnace in an alcove.
3. DO NOT install this furnace where it could be isolated by closing doors to the heated space.
4. DO NOT install this furnace in a travel trailer or recreational vehicle.
5. MAINTAIN all clearances specified in section "Locating Wall Furnace and Thermostat" and "Vent Installation."
6. BE SURE this furnace is for the type of gas to be used. Check the rating plate by the gas valve in the lower cabinet. Do not change it to use other gases without the proper manufacturer's Gas Conversion Kit.
7. For natural gas, the minimum inlet gas supply pressure for the purpose of input adjustment is 5" water column. The maximum inlet gas supply pressure is 7" water column.  
For L.P. Gas, the minimum inlet gas supply pressure for the purpose of input adjustment is 11" water column. The maximum inlet gas supply pressure is 13" water column.
8. Any safety screen, guard or parts removed for servicing this appliance must be replaced prior to operating the appliance to avoid property damage, bodily injury or death.

9. Install the furnace vent directly to the outdoors so that harmful combustible flue gases will not collect inside the building. Follow the venting instructions for your type of installation exactly. Use only the type and size of vent pipe and fittings specified.
10. BE SURE to provide for adequate combustion and ventilation air. The flow of this air to the furnace must not be blocked.
11. NEVER vent flue gases into another room, a fireplace or any space inside a building. This could cause property damage, bodily injury or death.
12. Never test for gas leaks with an open flame. Use a soap solution to check all gas connections. This will avoid the possibility of fire or explosion.
13. ALLOW the furnace to cool before servicing. Always shut off electricity and gas to furnace when working on it. This will prevent any electrical shocks or burns.
14. DUE TO HIGH TEMPERATURES, locate the furnace out of traffic and away from furniture and draperies.
15. ALERT children and adults to the hazards of high surface temperatures and warn them to keep away to avoid burns or clothing ignition.
16. CAREFULLY supervise young children when they are in the same room with the furnace.
17. DO NOT place clothing or other flammable material on or near furnace.
18. INSTALLATION and REPAIR must be done by a qualified service person. The appliance should be inspected before use and at least annually by a professional service person. More frequent cleaning may be required due to excessive lint from carpeting, bedding material, etc. It is imperative that control compartments, burners and circulating air passages be kept clean.
19. BEFORE INSTALLING: To avoid electrical shock, turn off electrical circuits that pass through the wall where you are going to install the furnace.
20. BE AWARE of good safety practices by wearing personal protective equipment such as gloves and safety glasses to avoid being injured by sharp metal edges in or around the furnace and while cutting or drilling holes in wood and/or sheet metal.
21. CAUTION: Label all wires prior to disconnection when servicing controls.

**WARNING:** Do not use this furnace if any part has been under water. Immediately call a certified service technician to inspect the furnace and to replace any part of the control system and any gas control which has been under water.

**WARNING:** Do not install any of these furnaces (Natural or L.P. Gas) in mobile homes, trucks or recreational vehicles.

# Introduction

---

## ***A Word from the Manufacturer***

*Dear Customer,*

*To set up our furnace assembly procedures, several hundred quality assurance, safety audit and design performance tests have been conducted according to the standards provided by the American National Standards Institute, the Department of Energy and our certification agency – (CSA) Canadian Standards Association.*

*This was done to assure you of receiving the best value and most reliable appliance of its type available today. We are confident that your Williams furnace can provide you years of low cost, efficient, heating comfort.*

*Thank you for purchasing a Williams furnace.*

*Sincerely,  
Employees of Williams Furnace Company*

Please read our instructions before you install and use your furnace. This will help you obtain the full value from this furnace. It could help you avoid needless service costs, if the answer to the problem is found within this instruction manual.

## **Basic Description**

---

The direct vent wall furnace is shipped ready to install against an exterior wall not exceeding 9" in thickness. Furnace may also be recessed up to 10" in a wall with studs spaced 16" center-to-center.

Always consult your local heating or plumbing inspector, building department or gas utility company regarding regulations, codes or ordinances which apply to the installation of a direct vent furnace.

Air is drawn in at the top by the fan and discharged through a grille near the floor. A two-speed fan is used with models 5507332, 6007732, 5507331, and 6007731. A single speed fan is used on all other models. The furnace contains a multi-slot burner (two on models 5507332, 6007732, 5507331, and 6007731) and burns either natural or L.P.G (liquefied petroleum gas), depending on the model you have purchased.

The sealed combustion system draws combustion air directly from outdoors into the combustion chamber and combustion gases are discharged directly to the outdoors through tubes mounted to the rear of the furnace.

The furnace heat exchanger is built of heavy gauge steel treated for corrosion resistance. The fan at the top, forces air down along the front, back and sides of the heat exchanger where it is discharged into the room. The furnace cabinet is also constructed of heavy gauge steel and has a powder-coat paint finish.

The furnace controls are located behind an access door on the lower front of the furnace. All models are equipped with American Gas Association listed gas valves and pilots.

Models 4007332, 4007331, 5507332, and 5507331 are equipped with an electronic ignition automatic pilot relight system.

## **Tools Needed**

---

Hand drill or properly grounded electric drill  
Expansion bit 1/2" to 1-5/8" or 1/2" and 1-1/2" blade bits  
1/8" and 3/16" drill bit (metal)  
6 ft. folding rule or tape measure  
Screwdrivers (med. blade) and (Phillips Head)  
Pliers (wire cutting)  
Hammers  
1/8" allen wrench

Stud locator or small finishing nails.  
Tin snips  
8" and 12" adjustable wrenches  
Keyhole or sabre saw  
Hack saw  
2 - 10" or 12" pipe wrenches  
Gloves and safety glasses

## **Materials**

---

Pipe and fittings to make connections to furnace (See page 18).  
Caulking compound-silicone rubber with a temperature rating of 500°F.  
DO NOT use caulking compound advertised as paintable or for bath tub use as most contain fillers and will not withstand high temperatures.  
Pipe Joint Compound resistant to L.P. Gas.

Electrical wiring supplied as needed (see page 19). Minimum wire size is #14 gauge copper.  
3/4" Quarter Round or other wood trim molding approx. 16' long or **Trim Strip Kit 4701**.  
2" x 4" x (length as required) Spacer Block (See Page 9).  
1" x 1" wood strips if **Optional Side Outlet Grille Kit 6701** is used.

## **Helpful Installation Information**

---

The following booklets will help you in making the installation:

ANSI/NFPA 70-1990 or current edition "National Electrical Code". In Canada: CSA C22.1 Canadian Electrical Code.

American National Standard NFPA54/ANSI Z223.1 1988 or current edition "National Fuel Gas Code".

Obtained from: American National Standards Institute, Inc., 1430 Broadway, New York, N Y 10018.

In Canada: CAN/CGA B149.

# Introduction

## Optional Accessories

### SIDE OUTLET GRILLE KIT 6701

Let's you route some heated air into a second room. Mounts on the side wall of second room and must be within 10 inches of wall furnace. See pages 7 and 10.

### DIFFUSER GRILLE KITS 6703 & 6704

6703 let's you route some heated air in a two-way direction. Kit 6704 for one-way direction.

### SIDE GRILLE KIT 6702

## Unpack Your Furnace

The furnace is shipped in one carton, containing the furnace, installation instruction booklet, hardware bag, vent cap with inlet and vent tubes.

1. Lay the carton horizontally.
2. The bottom front panel can be removed by grasping just below the handle and pulling it outward and then upward. See Fig. 1.
3. Place these and other parts, as they are removed from furnace, where they cannot be lost or damaged before you need them.

### NOTE

Check the burner rating plate, located in burner compartment, to make sure your furnace is equipped to operate on the type of gas available (either Natural or L.P. Gas).

4. Remove all literature, wire and metal anchors used for free standing installation.
5. Check the fan blade to be sure it spins freely.
6. Take out the four screws holding fan shroud to the side flanges of cabinet and remove shroud. See Figure 1.

### NOTE

The fan blade must be removed in order to remove the cardboard shipping brace located under motor.

7. Before removing the fan blade, remember its position by examining the blade nut and the amount of shaft visible. Scribe or mark the motor shaft in order to reinstall the fan blade to its original place on the shaft.
8. Loosen the 1/8" "Allen head" set screw holding the fan blade to motor shaft and remove the fan. Place the fan blade and fan shroud where they will not be damaged.
9. Remove the cardboard shipping brace located under the motor mounting brackets.
10. Properly dispose of shipping materials.

Let's you route some heated air to side of furnace in the same room. See pages 7 and 10.

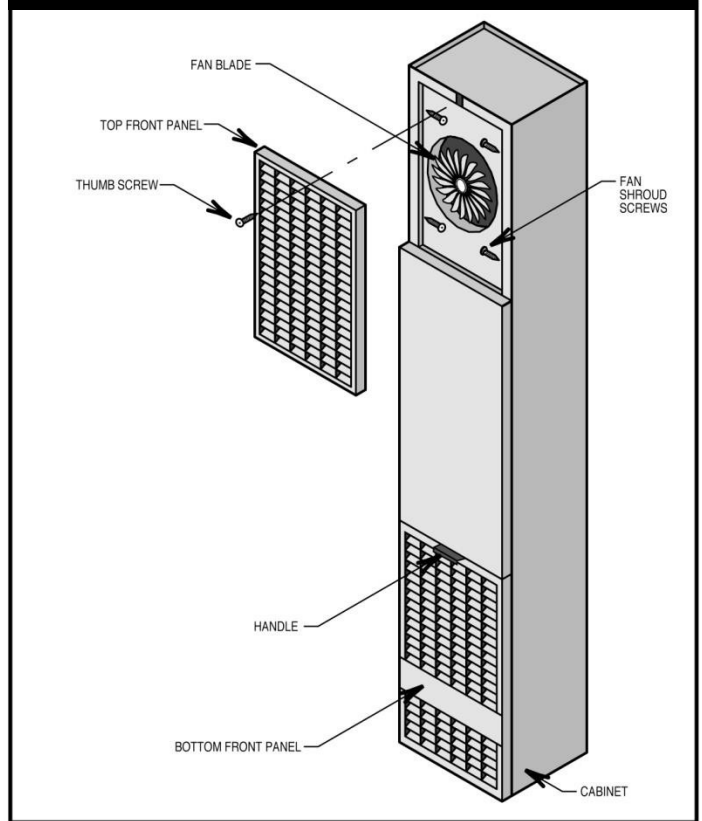
### TRIM STRIP KIT 4701

Provides a finished edge at sides of wall furnace. Neutral beige enamel painted steel.

### THERMOSTAT P322016

Note: Kits are identified on the carton by manufacturing number 6701, 6702, 6703 and 6704 are also listed on the furnace rating plate.

**FIGURE 1**



# Installing Your Furnace

The following steps are needed for proper installation and safe operation of your furnace. If you have any doubts as to any requirements, always consult your local Heating or Plumbing Inspector, Building Department or Gas Utility Company regarding regulations, codes, or ordinances which apply to the installation of a vented wall furnace. Obtain professional help where needed.

The CHECK AND ADJUSTMENTS on page 21 are vital to the proper and safe operation of the furnace. Be sure they are done.

## IMPORTANT

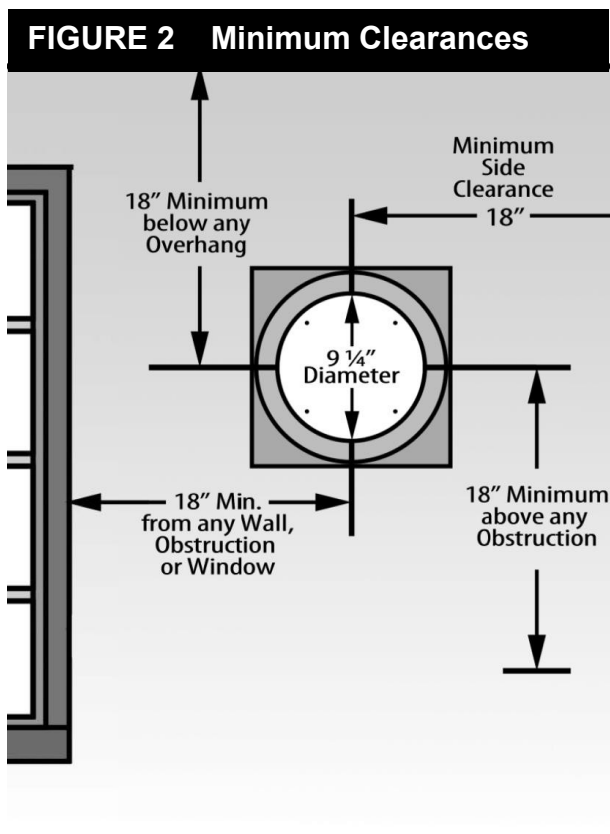
For satisfactory and trouble-free operation, be sure to:

## Locating Wall Furnace & Thermostat

Consider the following points before attempting to install the furnace:

1. This is a direct-vent wall furnace. It must be installed on an OUTSIDE WALL for proper venting of flue gases (Fig. 2).
  - a. Ideally, the wall should be on the least windy side of the dwelling, as strong gusts may extinguish the pilot.
  - b. Furnace may be installed flush against a wall or recessed up to 10" maximum. Wall thickness from back surface of furnace to outside of wall can be 3/4" minimum to 9" maximum. See Page 8, Fig. 3.

With standard furnace discharge outlet, do not install closer than 4" to intersecting wall. See Page 8, Fig. 4.



1. Locate the furnace properly within the space to be heated.
2. Install the furnace in accordance with local codes or ordinances and instructions provided. In the absence of local codes or ordinances, install the furnace to conform with the current edition of the National Fuel Gas Code, NFPA 54, ANSI Z223.1/Canadian Installation Code, CAN/CGA B149.
3. Maintain minimum clearance: Floor 0 inches or ceiling 4 inches, side wall 4 inches. For exception to minimum side wall clearance, as shown on Page 8, Figs. 4, 5, 6 & 7.
4. Provide for adequate combustion air around vent cap on outside, see Fig. 2 and adequate air circulation around cabinet inside the open room.

Studs must be spaced on 16-inch centers or stud space will have to be framed in. See Page 9 and 10, Recessed Mounting.

2. The top of the furnace must be at least 4-inches from the ceiling.
3. Check the clearances needed from the furnace and vent (Page 7, Fig. 2 and Page 8, Fig. 4). You must place the furnace where you will have no less than the clearances shown. See Page 8, Fig. 5, 6 & 7.
4. When using optional kits 6703 or 6704, maintain the clearances as shown on Page 8, Fig. 5, 6 & 7.
5. When using optional kit 6701, maintain clearance as shown on Page 8, Fig. 4. Use only optional outlet and grille kits available from manufacturer.
6. The outside vent cap must be at least 18-inches away from any window or other building opening (Fig. 2).
7. The furnace will not work if anything stops free entry of fresh air into the vent, or free flow of flue gases from it. Be sure the center of the vent cap is at least 18-inches above ground level or shrubs are as shown in Fig. 2. Make sure shrubs are kept trimmed. It must also be at least 18 inches from any overhang.
8. Try to place the furnace near the center of the space to be heated for good air circulation. Do not put it behind a door or draperies. Do not put in a closet, alcove, hallway or other confined space.
9. Be sure that gas piping and electrical wiring can be brought to the furnace. See sections on gas piping and electrical wiring for your type of furnace mounting.
10. The bottom of the furnace must rest directly on a wood or concrete floor. If the floor is other than wood or concrete, such as carpet or sheet vinyl flooring, there must be a piece of wood or sheet metal under the furnace that is at least the same size as the bottom of the furnace.

**WARNING:** If vinyl siding is used on exterior wall surface, heat from the vent cap could cause distortion/discoloration. Shield to protect the siding. Check with manufacturer for additional options.

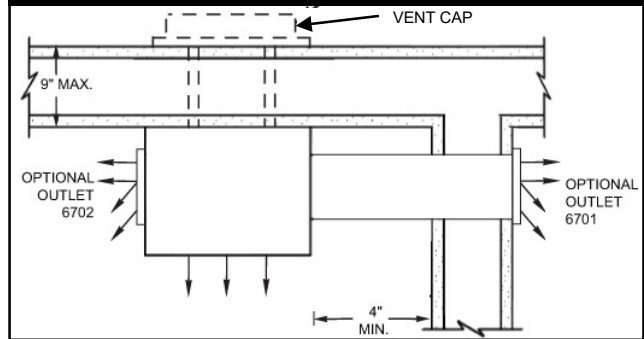
# Installing Your Furnace

- Be sure to provide adequate clearance and service access. The front of the furnace must face the open room.
- Choose a location for the thermostat (optional) about 5-feet above the floor on an inside wall. The thermostat wire supplied with your furnace is 20-feet long, which should be enough to run up through the attic of a single-story home, so the thermostat can be a maximum of 16-feet from the furnace measure in a straight line, or about 8-feet from the furnace if the wire is run under the floor. Use heavier wire size if more than 20-feet of wire is required. The thermostat should be sensing average room temperature. Avoid the following:

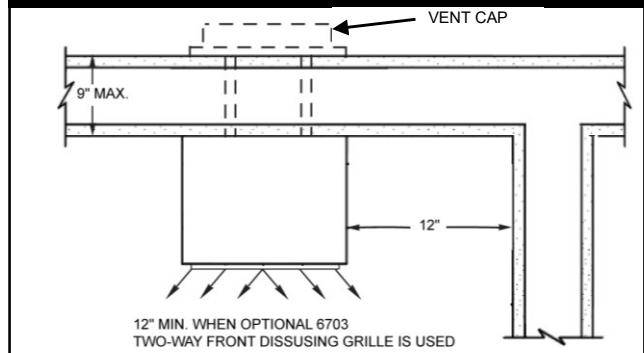
<b>HOT SPOTS:</b>	<b>COLDSPOTS:</b>
Concealed pipes or ducts	Concealed pipes or ducts
Fireplaces	Stairwells – drafts
Registers	Doors – drafts
TV sets	Unheated rooms on the other side of the wall
Radios	<b>DEAD SPOTS</b>
Lamps	Behind doors
Direct sunlight	Corners, and alcoves
Kitchen	

- After picking a location that meets the requirements, inspect the wall, floor and outside areas. Make sure there are no pipes, wiring, or anything else that would interfere with furnace, vent, or thermostat installation. If required, move them or pick a new location.

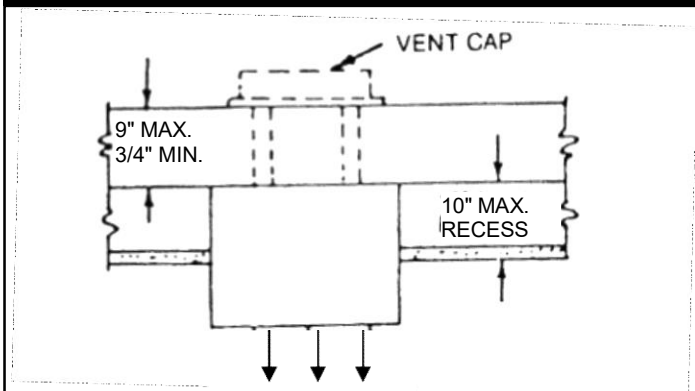
**FIGURE 4**



**FIGURE 5**



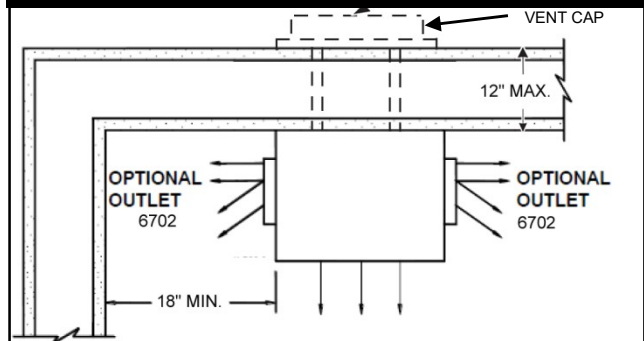
**FIGURE 3 Recessed Installation Clearance**



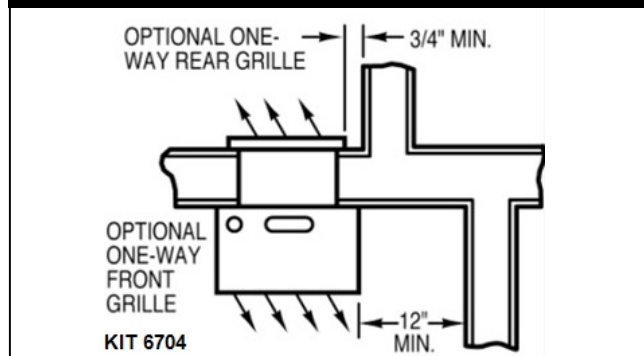
**RECESSED INSTALLATION CLEARANCE**

**NOTE:** A portion of the furnace that is recessed into a wall up to 10" maximum recess may have (0) zero inch clearance to combustibles. (See Fig. 3). All other clearances for the unrecessed portion must be observed. 3/4-inch to 5-inch outer wall will require thin wall collar accessory Kit 9307.

**FIGURE 6**



**FIGURE 7**





# Installing Your Furnace

## Recessed Mount Installation

### FIND THE STUDS

Use a stud locator or small finishing nails. Repeatedly drive and remove a nail into the wall in the area of the stud until you find it. Then find one side. Leave the nail there. Drive another nail just on the other side of the same stud.

Inside edge of the other stud should be about 14½-inches from the one found. Drive finishing nail on inside edge of this stud.

**NOTE:** If studs are not on 16-inch centers, see section "Close off Stud Space", below.

### CUT WALL OPENING

1. Lay out the required opening to be cut in inside wall (Fig. 8). Mark center of the vent hole on wall. Using a window, door or wall corner for reference, measure to find where vent will be on outside wall. Check to be sure clearances (Page 7, Fig. 2, and Page 8, Fig. 4, 5, 6 and 7) will be right.
2. Drill a ¼-inch hole through vent hole center to the outside wall to mark vent location.
3. Make the required cutout in inside wall. (Fig. 8).
4. Using the hole drilled through to the outside wall as the center, cut a 9¼-inch diameter hole for the vent. It may be better to work from outside, especially when breaking through brick, stone or tile. (See Fig. 8).
5. In new stud wall construction, install blocks as shown in Figure 7 and install plaster grounds around inside of wall opening.
6. The vertical height of the opening shown is 3-inches greater than height of furnace to allow space for connection of wiring after furnace is installed.

**NOTE:** Vertical measurements are from finished floor. (Fig. 7).

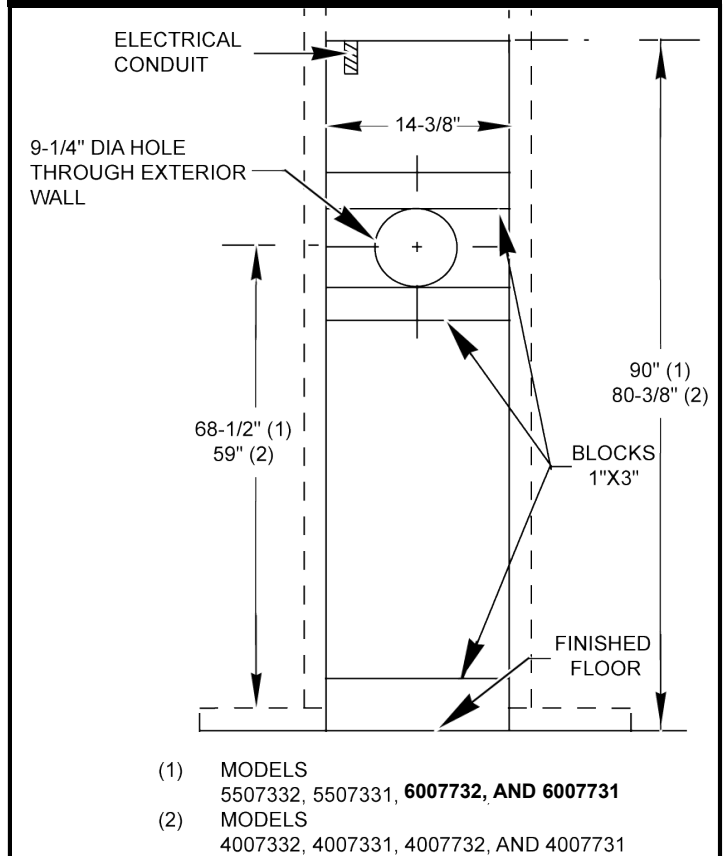
### CLOSE OFF STUD SPACE (If Required)

If studs are not on 16-inch centers, cut the hole for the furnace next to an existing stud and frame in the other side using a 2"x 4" and spacer blocks as required. As shown on Page 9, Fig. 9.

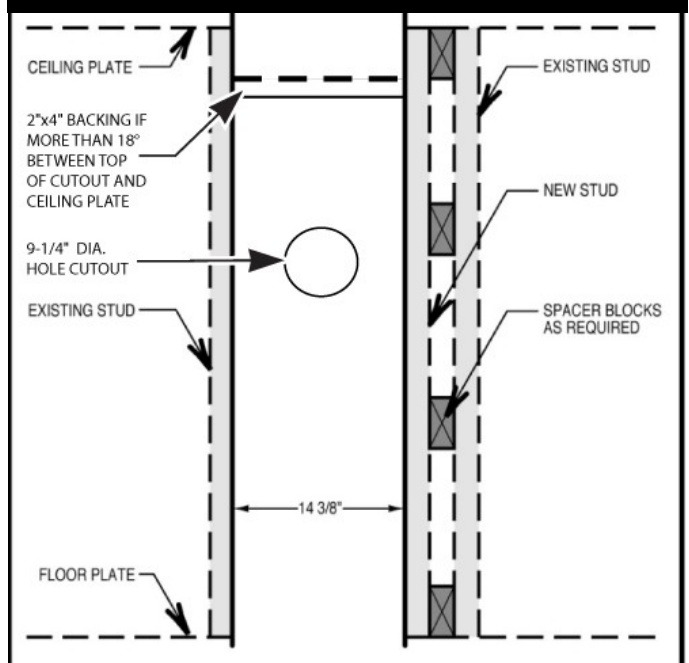
If the distance from the top of the cutout to the ceiling wall plate is more than 18-inches, it is recommended that it be closed off.

Nail a 2"x 4" long enough to go between the studs at the top of the opening to close off the stud space.

**FIGURE 8 Wall Opening for Recessed Mount**

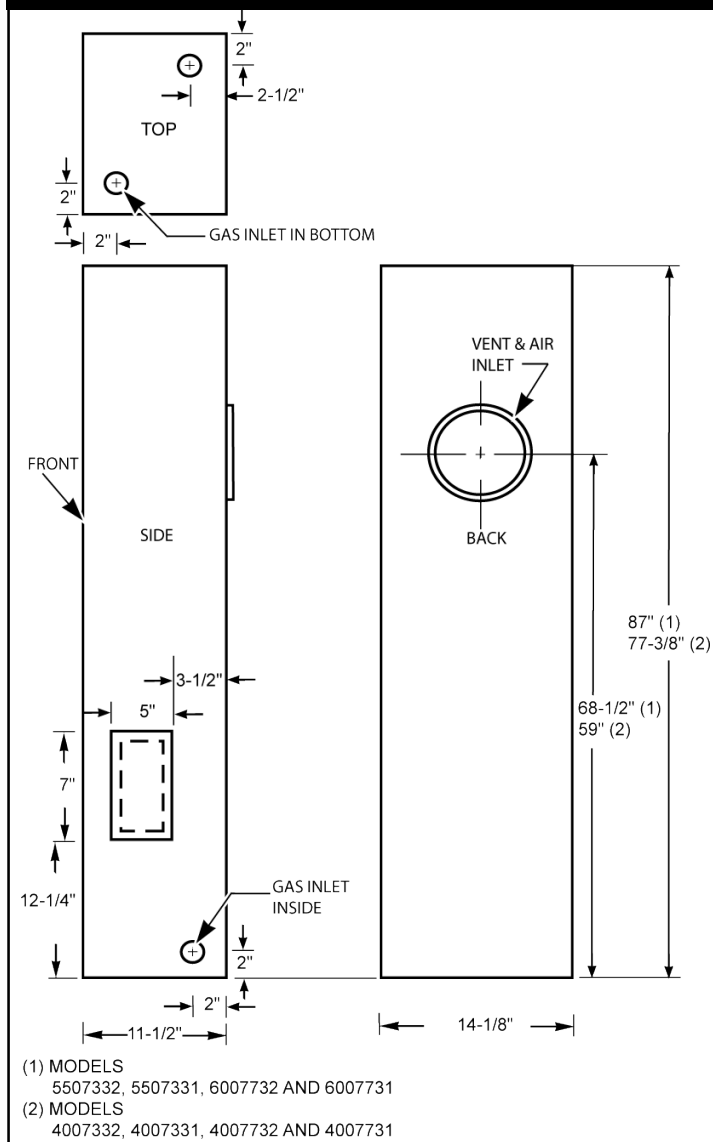


**FIGURE 9 Close Off Stud Space**



# Installing Your Furnace

**FIGURE 10 Gas & Electrical Openings**



## GAS AND ELECTRICAL SUPPLY OPENINGS

Holes must be drilled for the gas line and electrical supply. Holes must be located from each side of furnace as shown in Fig. 10.

Decide whether the gas line will come through the floor or wall.

Drill a 1½ -inch hole in wall or floor as needed.

Gas line can be run at this time or done after furnace is mounted, see section GAS SUPPLY AND PIPING, on Page 18.

The electrical supply opening should be at the lower portion of the furnace, to match openings shown in Fig. 10. Mark ceiling wall plate and drill holes. If not practical to run wiring from the attic, drill holes through wall stud and run wires up through adjoining stud space from crawl space or basement.

Run the electrical supply with the ground wire and thermostat cable to the openings. Leave enough length to connect in the junction box after the furnace is installed. See section "Electrical Wiring," on page 19.

**CAUTION:** Do not run wire in any location where it might be damaged. Avoid splicing thermostat wire unless the spliced wires are properly cleaned, soldered, and taped.

## Offset Wall Installation

To mount the wall furnace on an offset wall, the area behind the furnace must be made flush or flat.

Use lumber (2"x 4"s, 2"x 6"s etc.) to make the surface flush with other portion of wall.

Use sheet rock or paneling etc. to finish area.

Follow procedures under Surface Mount Installation.

# Installing Your Furnace

## Surface Mount Installation

### FIND THE STUDS

1. Find two studs at spot where furnace is to be placed. Use a stud indicator or small finishing nails. Repeatedly drive and remove a nail into the wall in the area of the stud until you find it. Then find one side. Leave the nail there. Drive another nail just on the other side of the same stud.
2. Inside edge of the other stud should be about 14½-inches from the one found. Drive finishing nail on inside edge of this stud.

### CUT VENT OPENINGS

1. Lay out and mark the center of the hole to be cut through the wall for the vent (Page 9, Fig. 8). Using a window, door, or wall corner for reference, measure to find where vent will be on outside wall. Check to be sure clearances are correct. (See Pages 7 & 8, Fig. 2, 4, 5, 6 & 7).
2. Drill a ¼-inch hole through vent hole center to the outside. Cut the 9¼-inch diameter hole through inside wall. Using the ¼-inch hole as the center, cut a matching hole in outside wall. It may be better to work from the outside, especially when breaking through brick, stone or tile.

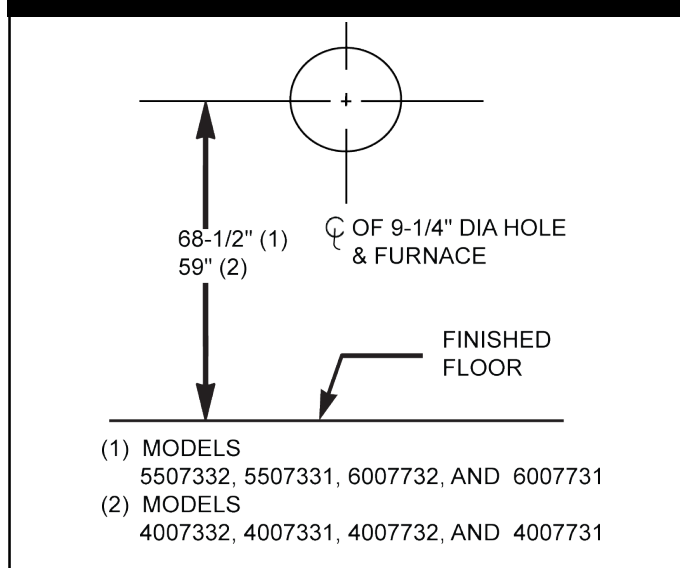
### GAS AND ELECTRICAL SUPPLY OPENINGS

Holes must be drilled for the gas line and electrical supply. Holes must be located from each side of furnace as shown on Page 10, Fig. 10.

Drill a 1½-inch hole in floor or wall for gas line.

Gas line can be run at this time or done after furnace is mounted, see section: Gas Supply and Piping, Page. 18. Mark ceiling or wall to match wall furnace openings and drill a 1-inch hole for the power supply and a ½-inch hole for the thermostat cable. Run the electrical supply and ground wires to the opening. Leave enough length to connect in the junction box after the furnace is installed. See section "Electrical Wiring," Page 19.

**FIGURE 11 Wall Opening (Surface Mount)**

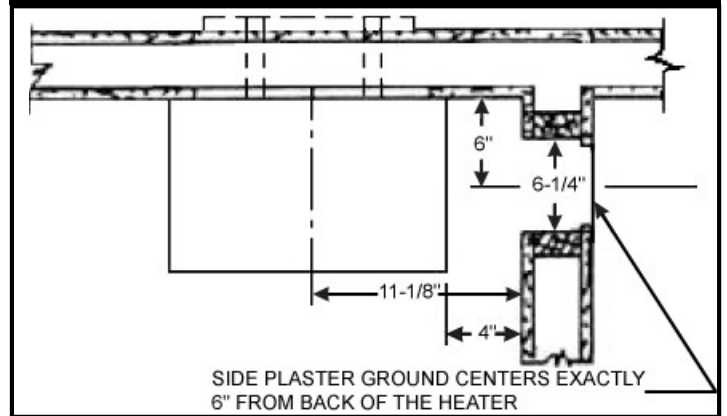


### ROUGH-IN OPTIONAL SIDE OUTLET NO. 6701

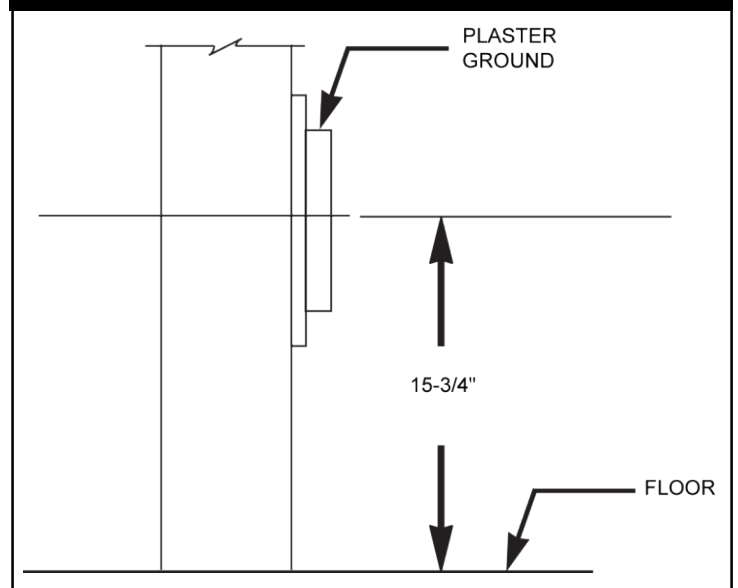
Install plaster ground as shown in Figs. 12 & 13. Flanges of plaster ground extend the thickness of normal plaster. If "dry-wall" or other thin material, flanges must be trimmed off flush with wall surface.

Follow measurements given carefully, and note that when a side outlet is used, the furnace casing must be exactly 4 inches from surface of adjacent wall except minimum clearance may be ¾-inch when optional 1-way Diffusing Grille Kit 6704 is used.

**FIGURE 12 Plaster Ground Installation**



**FIGURE 13 Plaster Ground Installation**



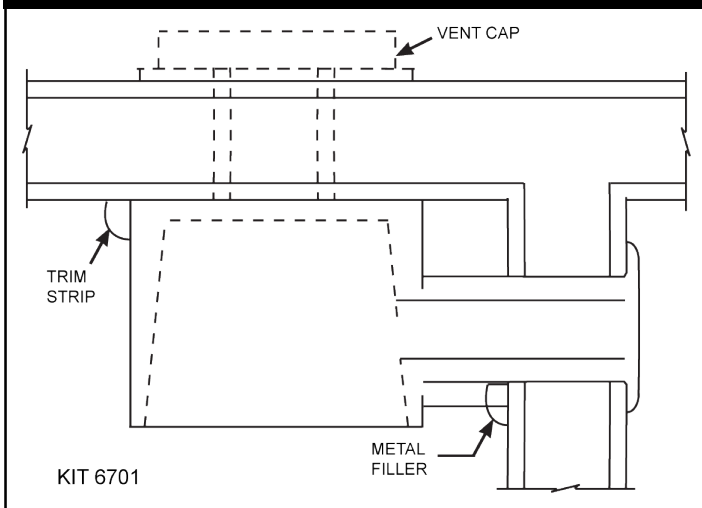
# Installing Your Furnace

## MOUNTING OPTIONAL SIDE OUTLET GRILLE KIT NO. 6701

Refer to Fig. 14.

1. Before setting furnace into position, cut 5"x 7" rectangular opening in furnace outer casing where marked. See Page 10, Fig. 10.
2. Place the outer boot against casing with inner flanges exactly on edges of cut hole, mark screw location, remove boot and drill #33 holes for the sheet metal screws.
3. Remove the knockout plate and knockouts for screws from the inner liner.
4. Secure 1"x 1" wood strip (not included with this kit) to the wall next to the side outlet as a backup for metal filler strips.
5. Fasten metal filler strips to the side of the furnace casing with the front surface exactly opposite the front of wood backup strip.
6. After the furnace is placed in position, place the outer boot through the plaster ground tight against the furnace casing. Then mark and cut off the outer end flush with the wall surface.
7. Press the inner boot against liner, mark and cut it off flush with the wall surface. Install the outer boot first, then the inner boot, fastening through all holes with the screws provided.

**FIGURE 14 Mounting Grille Kit 6701**



## OPTIONAL 2-WAY DIFFUSING GRILLE KIT NO. 6703

Refer to Fig. 15.

**CAUTION:** For use only in conjunction with a front outlet when the furnace is spaced at least 12-inches from an intersecting wall (see Page 8, Fig. 5).

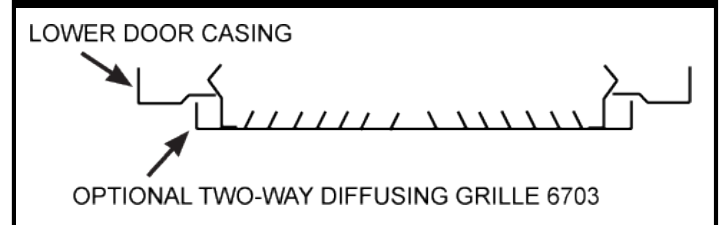
Metal clips on backside of the optional grille snap into the side louvers of the front warm air outlet. Adjust clips with pliers if necessary. Grille may also be attached with sheet metal screws.

## 1-WAY FRONT DIFFUSING GRILLE KIT NO. 6704

Follow instructions for 2-WAY FRONT DIFFUSING GRILLE 6703 ABOVE, except furnace clearance to an adjacent wall must be  $\frac{3}{4}$ -inch minimum.

**CAUTION:** Use only optional kits available from the manufacturer.

**FIGURE 15 Two-Way Diffusing Grille 6703**



# Installing Your Furnace

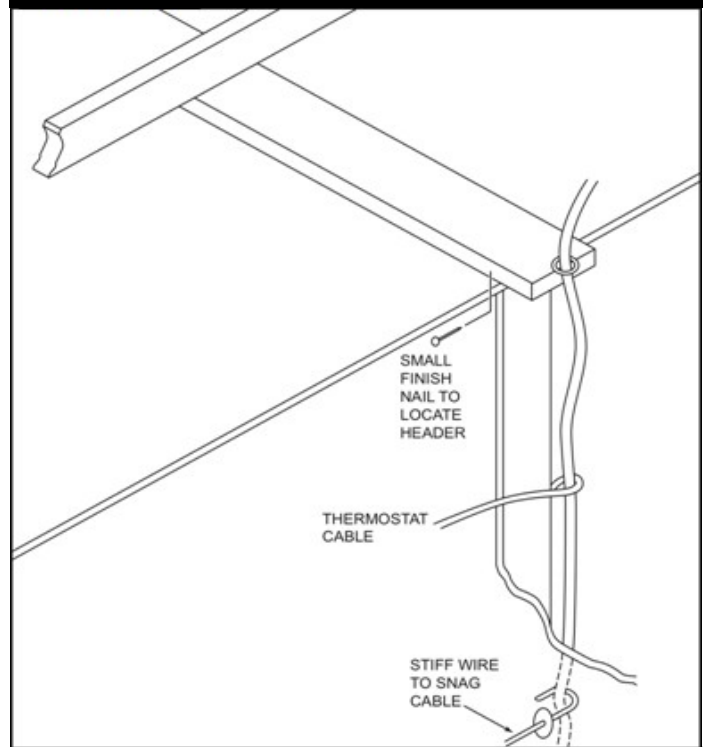
## Thermostat Installation (Sold Separately)

1. Use Williams thermostat P322016 or any millivolt thermostat.
2. If an old thermostat is being replaced and is in a satisfactory location and the wiring appears to be in good condition, use existing wiring. If in doubt, use new wire.
3. If a new location is chosen or if this is a new installation, thermostat cable must first be run to the location selected. All wiring must agree with local codes and ordinances. These instructions cover bringing the wire down from the attic but it can be run from a basement or crawl space using similar methods.
4. Before drilling a hole in the wall at selected location, drive a small finishing nail through the ceiling in the corner of the wall and ceiling above the thermostat location. Pull the nail out and push a small stiff wire through the hole so it can be found in the attic. Drill a ½-inch hole through the ceiling wall plate.
5. Probe for obstructions in the partition. Then drill a ½-inch hole through wall at the selected location for thermostat.
6. From the attic, feed the thermostat cable or a stiff wire through wall until even with thermostat location.
7. Snag thermostat cable through the hole and pull the cable through the hole in wall so that 6-inches of cable protrudes.
8. Route cable to wall furnace.

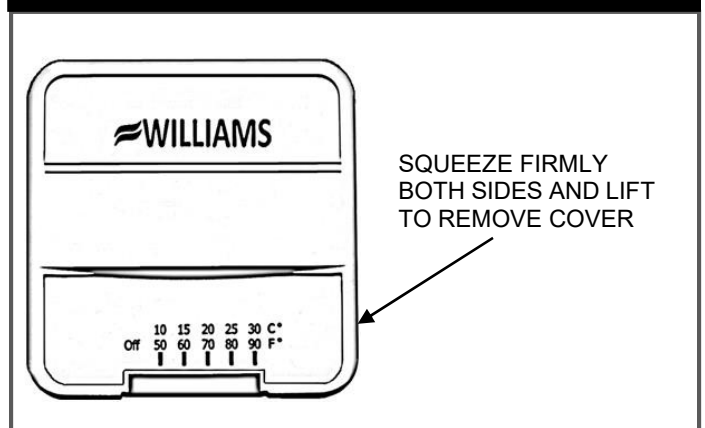
### MOUNTING THE THERMOSTAT

1. To remove thermostat cover, squeeze both sides and lift. Carefully remove and discard the packing tab protecting the switch contacts. See Fig 17.
2. Connect the thermostat wires to the terminal screws on the thermostat base. Make sure the wiring does not interfere with thermostat operation.
3. Push any excess wire back through the hole in the wall and plug the hole with insulation to prevent drafts from affecting thermostat operation.
4. Being sure to level the thermostat for best appearance, fasten the thermostat base to the wall through the mounting holes with the screws provided.
5. Replace the thermostat cover.

**FIGURE 16 Route Thermostat Cable**



**FIGURE 17 Thermostat**



# Installing Your Furnace

## Vent Installation

**WARNING:** DANGER OF PROPERTY DAMAGE, BODILY INJURY OR DEATH.

Proper vent installation is critical to the safe operation of the furnace. Therefore, carefully read and follow all the instructions given in this section.

The following instructions are for either surface or recess mounted wall furnace.

USE ONLY THE VENT ASSEMBLY SUPPLIED.

**IMPORTANT:** All joints in the inlet and vent tubes and all gaskets must be tight. Installation in any other manner voids the C.S.A. design certification and will affect the warranty.

Refer to Page 15, Fig. 19 for the name and location of the vent parts.

### DETERMINE PROPER LENGTHS

**IMPORTANT:** To prevent harmful flue gases from entering the house, make sure NOT to trim air or vent tubes shorter than specified below.

Air inlet air tube 'A' and vent tube 'B' are supplied in lengths to handle wall thickness up to 8½-inches.

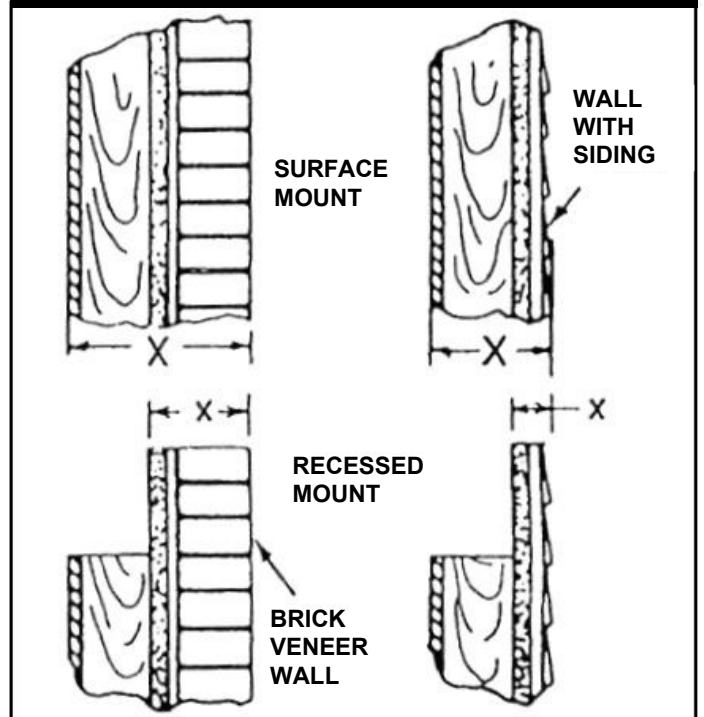
To find the correct vent and air tube length, measure exact distance 'X' between surface on which back of cabinet will rest (inside of recessed cavity or face of wall when freestanding) and the outside wall surface. See Page 14, Fig. 18 & Page 15, Fig. 19.

Inlet air tube 'A' – Add ⅞-inch to dimension 'X'. Mark on tube starting from end with collar and holes. Cut off evenly. File off any burrs resulting.

Vent tube 'B' – Add 2½-inches to dimension 'X'. Mark on tube starting from end with collar and holes. Cut off evenly. File off any burrs resulting.

CUT ONLY THE PLAIN END (WITHOUT THE FLANGE) OF THE TUBES. MAKE A SQUARE CUT TO THE EXACT LENGTH.

**FIGURE 18 Wall Thickness**



### HELPFUL CUTTING HINT

To make a straight cut, measure from the end and mark tube in several places. Align a piece of tape with the marks and wrap it around the tube. Use the edge of the tape as a guide to help keep the cut straight.

### ATTACHING TUBE TO FURNACE

The smaller diameter vent tube (Page 15, Fig. 19-"B") must be installed first.

The easiest way to install the vent tubes and get the gaskets positioned properly is to have the furnace lying front down on a flat surface.

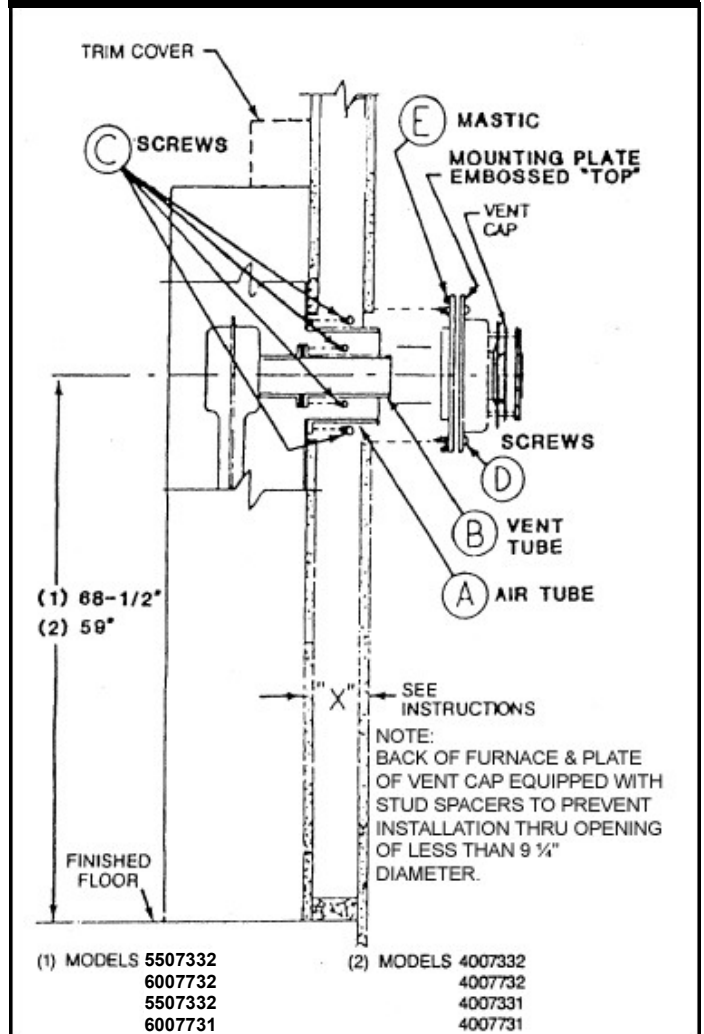
**IMPORTANT:** To prevent harmful flue gases from entering the house, make sure NOT to trim air or vent tubes shorter than specified below.

1. Attach vent tube (Page 15, Fig. 19-"B") and gasket to the back of the furnace heat exchanger with (8) #8 x ⅜-inch sheet metal screws provided.
2. Attach air tube (Page 15, Fig. 19-"A") and gasket to the back of the furnace casting with (8) #8 x ⅜-inch sheet metal screws provided.

# Installing Your Furnace

**NOTE:** Each tube must overlap the collars of the vent cap a minimum of 1¼-inches, which is obtained when tubes are cut correctly as previously described.

**FIGURE 19 Vent Installation**



## Trim

To conceal the space between the furnace and wall, use 4701 Trip Strip Package (not furnished with furnace), 3/4-inch round or other wood trim.

### TRIM COVER

Place the trim cover on top of the furnace. See Page 16, Fig. 20. Drill through the top casing flange and fasten each side with a sheet metal screw. This plate covers the space between the top of the furnace and wall opening after electrical connections are made.

### MOUNT FURNACE THROUGH WALL

Mount the furnace through the wall using surface or recessed mounting instructions. See Pages 9 thru 12.

Refer to Fig. 19 for the following steps.

1. Check to see that the air tube protrudes through wall 7/8-inch min. to 1-inch max. for proper seal in vent cap.

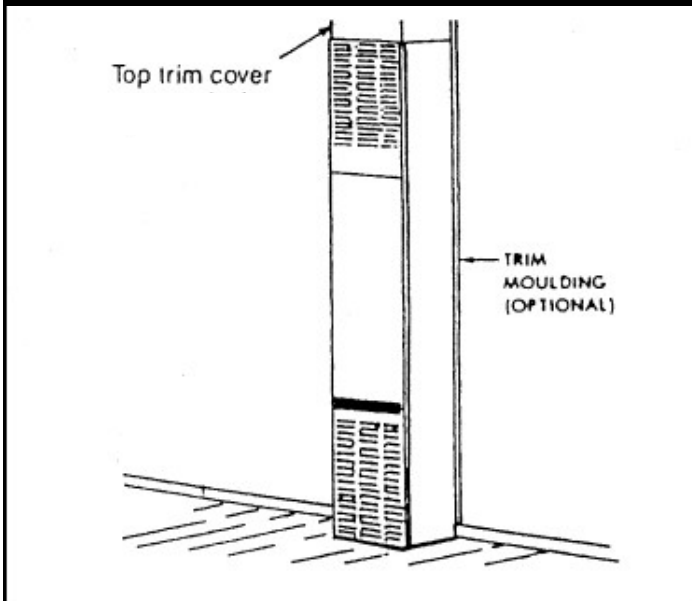
2. Check to see that the vent tube protrudes past the air tube 1/8 inch min. to 1/4-inch max. for proper seal in vent cap.
3. Apply a single strip of mastic ("E" provided in the vent cap carton) continuously around the outer edge of the vent cap mounting plate.
4. Holding the vent cap in an upright position (embossed "top" on the mounting plate towards the top of the furnace), push it into place until the stops are contacted. If the stops prevent the mounting plate from reaching the wall, refer back to "DETERMINE PROPER LENGTHS" Page 14.

**NOTE:** The smaller tube in the vent cap must slide over the vent "B".

5. Fasten the vent cap mounting plate to the wall with (4) 1½-inch wood screws "D" provided.
6. On masonry construction, drill into the wall and use plugs or anchors. Additional sealant (silicone) may be required if the mounting surface is uneven.

# Installing Your Furnace

**FIGURE 20** Furnace Item



## Mounting Your Furnace

To obtain adequate clearance for fastening the furnace or to install gas supply fittings, it may be necessary to remove the burner and control assembly as follows:

**CAUTION:** Be careful not to damage burner pan gasket when removing burner and control assembly.

1. Lay the furnace on its back for the following steps.

Remove burner compartment door by pulling the door top out and up.

**MODELS: 4007332, 5507332**  
**4007331, 5507331**

- a. Remove the screws holding the ignition control unit and the cover to the casing.
- b. Remove (3) screws 'A' holding the burner pan to the upper heating element support (Page 17, Fig. 22). Rotate the burner pan toward the front until the (3) pins 'B' disengage from the upper heating element support.
- c. Remove necessary wiring to free the control module from its mounting location. Mark or tag each wire removed for its exact reconnection (Page 17, Fig. 23).
- d. Remove the burner and control assembly from furnace.

**MODELS: 4007732, 6007732**  
**4007731, 6007731**

- a. Remove the manual spark igniter and bracket by removing the (2) screws and disconnecting the wire at the back of the igniter.
- b. Disconnect the two (2) slip-on connectors (24 volt wires) from the gas valve.

- c. Remove the (3) screws 'A' holding burner pan to the upper heating element support (Page 17, Fig. 22). Rotate the burner toward the front until the (3) pins 'B' disengage from the upper heating element support slots.
- d. Remove the burner and control assembly from furnace.

**NOTE:** Attach vent tubes BEFORE mounting the furnace. See Pages 14 & 15.

2. If furnace is recessed in the wall, clear the recess of all debris.
3. Be sure the gas is shut off at the meter.
4. Before placing the furnace in position, remove the gas piping stub if necessary to locate the furnace.
5. After installing the vent tubes, carefully move the furnace into position, being sure not to bend the vent tubes.

### FASTEN FURNACE BOTTOM (SURFACE AND RECESSED MOUNT)

**NOTE:** Fasteners are not furnished because of different requirements of various types of wall construction.

Fasten the furnace to the floor through the holes provided in the furnace bottom. If you have concrete flooring, use an alternate fastening method. See Page 17, Fig. 21.

If the burner and control assembly were removed, replace them by reversing steps 1a through 1d.

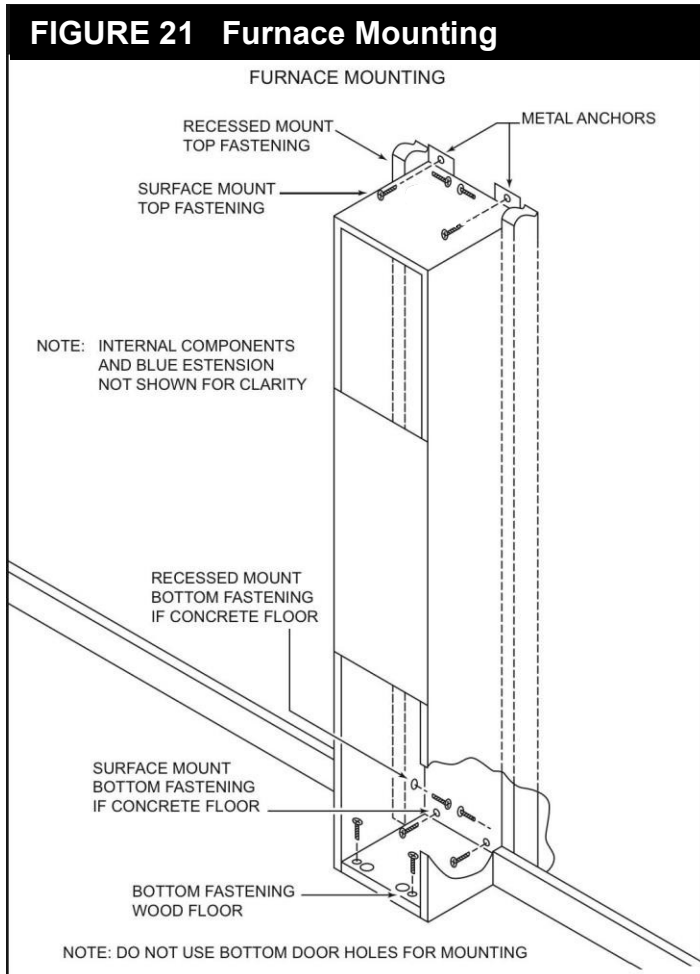
**IMPORTANT:** When replacing the burner and control assembly, be sure that pins "B" all enter the slots in the upper heating element support. To prevent damage to wiring, be careful not to pinch them between furnace components and route them away from the burner pan surface.



# Installing Your Furnace

## FASTEN FURNACE TOP (SURFACE MOUNTING)

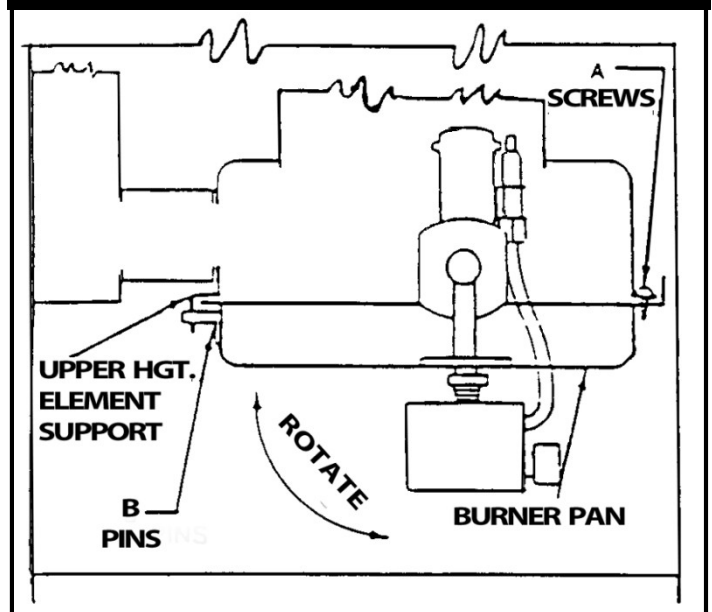
Fasten the furnace top to wall using two (2) metal anchors (packed in plastic bag with thermostat) by placing them over the back flange of the furnace top and screwing them to the wall. Refer to Fig. 21.



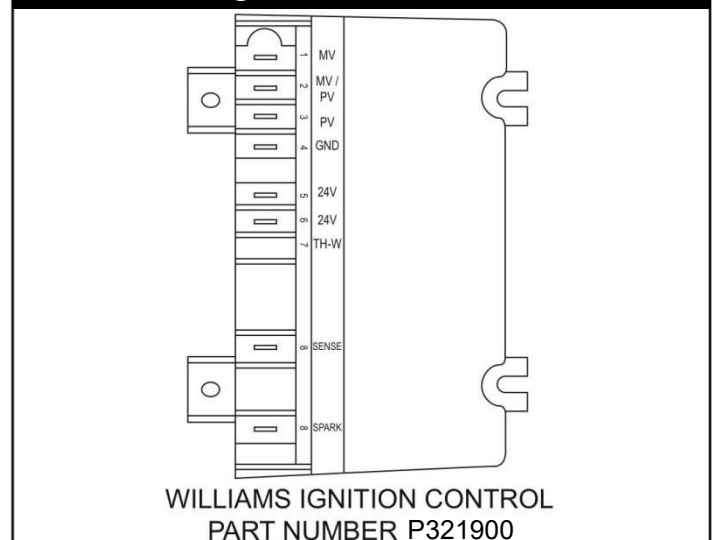
## FASTEN FURNACE TOP (RECESSED MOUNTING)

Fasten the furnace top by drilling two (2) holes through the side flanges of the furnace top and securing it with two (2) screws or nails into the wall studs. Refer to Fig. 21.

**FIGURE 22 Burner Pan**



**FIGURE 23 Ignition Control**



**CAUTION:** Be careful not to damage furnace components or wiring when drilling holes.

# Installing Your Furnace

## Gas Supply and Piping

The gas control valve within the furnace, is shipped with a seal over the gas inlet tapping. Do not remove seal until ready to connect piping.

**WARNING:** Danger of property damage, bodily injury or death. Make sure the furnace is equipped to operate on the type of gas available. Models designated as natural gas are to be used with natural gas only. Furnace designated for use with liquefied petroleum (L.P.) gas are to be used with commercially pure propane gas. They cannot be used with butane or a mixture of butane and propane.

### GAS SUPPLY

For Natural gas, the minimum inlet gas supply pressure for the purpose of input adjustment is 5-inches water column. The Maximum inlet gas supply pressure is 7-inches water column.

For L.P. Gas, the minimum inlet gas supply pressure for the purpose of input adjustment is 11-inches water column. The maximum inlet gas supply pressure is 13-inches water column.

Gas pressure and input to the burners must not exceed the rated input and pressure shown on the rating plate. On Natural Gas the manifold pressure should be 4-inches water column. The manifold pressure should be 10-inches water column for L.P. Gas. See Page 21 for operation above 2,000 feet altitude. Orifice change may be required to suit the gas supplied. Check with your local gas supplier.

### ORIFICE SIZES

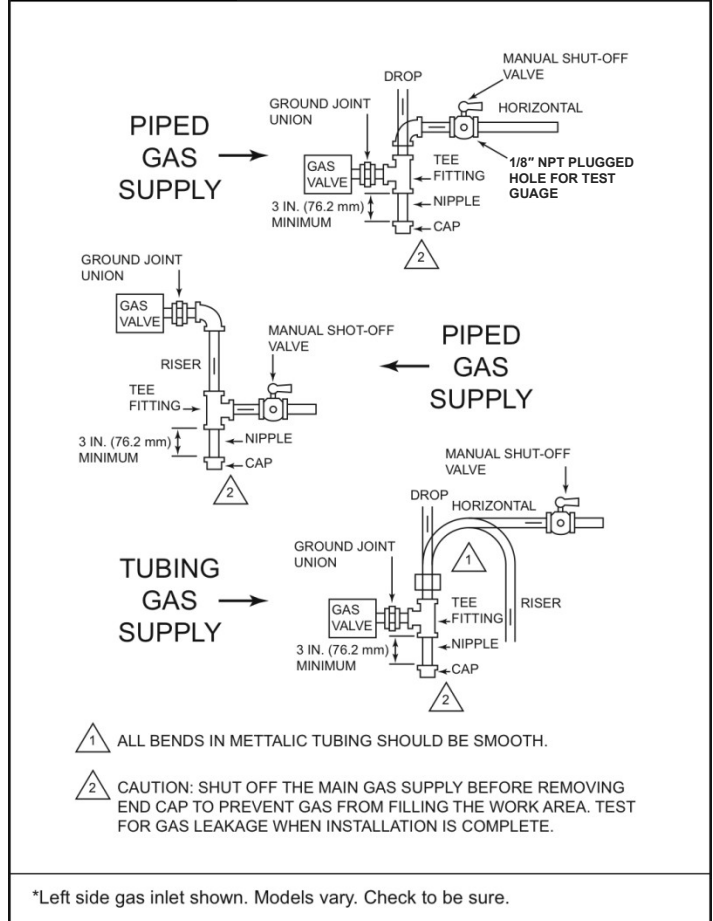
Furnace Technical Information, Page 29, shows the correct orifice sizes for the different input ratings when using Natural or L.P. Gas.

### GAS PIPING

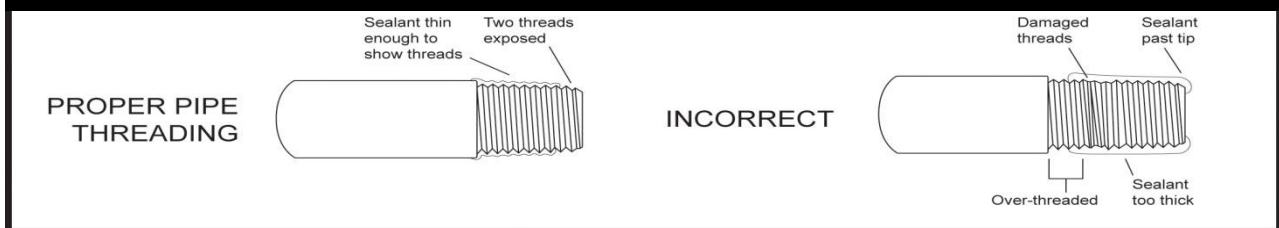
The gas supply line must be of adequate size to handle the Btu/hr. requirements and length of the run for the unit being installed.

Determine the minimum pipe size from Page 19, Fig. 26 basing the length of the run from the gas meter or source to the unit.

**FIGURE 24 Left Side Gas Inlet**



**FIGURE 25 Proper Piping Practice**



All piping must comply with local codes and ordinances or with the National Fuel Gas Code (ANSI Z223.1-1988), whichever applies. In Canada: Follow CAN/CGA-B149 Installation Code.

Refer to Page 18, Fig. 24, for the general layout at the unit. It shows the basic fittings needed.

# Installing Your Furnace

The following rules apply:

1. Use new, properly reamed pipe free from metal chips and debris such as steel or black iron pipe. Use fittings approved by local codes.
2. Do not thread pipe too far. Valve distortion or malfunction may result from excess pipe within control. Apply moderate amount of good quality dope to the pipe threads only, leaving 2 end threads bare. If LP Gas installation, use compound resistant to the action of liquefied petroleum gases.
3. Use ground joint unions.
4. Install a drip leg to trap dirt and moisture before it can enter the gas valve. Drip leg must be a minimum of 3-inches long.
5. Install a manual shut-off valve.
6. Provide a 1/8" NPT test gauge connection immediately before the gas supply connection to the furnace.

## GAS CONNECTION

If the installation is for L.P. Gas, have L.P. installer use two-stage regulation and make all connections from storage tank to furnace.

Use two pipe wrenches when making the connection to the valve to prevent turning or damage to the gas valve.

Connections between the manual shutoff valve and burner control assembly can be made with an A.G.A./C.G.A. design certified flexible connector if allowed by local codes. Drip leg and ground joint unions are still required.

Tighten all joints securely.

## CHECKING THE GAS PIPING

Test all piping for leaks. When checking gas piping to the furnace with gas pressure less than 1/2 psi, shut off the manual gas valve to the furnace. If gas piping is to be checked with the pressure at or above 1/2 psi, the furnace and manual shut off valve must be

## Electrical Wiring

**WARNING:** Danger of property damage, bodily injury or death. Turn off electric power at the fuse box or service panel before making any electrical connections. Insulate where necessary. All line voltage and ground connections must be completed before electrical power is restored.

All electrical work must conform to your local codes and ordinances or in their absence, with National Electrical Code, ANSI/NFPA 70. If you are not familiar with wiring codes, in general, have a competent electrician do this job. In Canada: Follow C22.1, Canadian Electrical Code.

**CAUTION:** Label all wires prior to disconnection when servicing controls. Wiring errors can cause improper and dangerous operation. Verify proper operation after servicing.

**CAUTION:** Do not connect 115V service line to the gas control valve or wall thermostat.

disconnected during testing. (SEE WARNING) Apply soap solution to each joint. Bubbles forming indicate a leak. Correct even the slightest leak at once.

**FIGURE 26 Gas Pipe Sizes**

NATURAL GAS PIPE CAPACITY - Btu/hr. (INCLUDES FITTINGS) PIPE SIZE			
LENGTH OF PIPE - FEET	1/2 INCH	3/4 INCH	1 INCH
20	92,000	190,000	350,000
40	63,000	130,000	245,000
60	50,000	105,000	195,000
L.P. GAS PIPE CAPACITY - Btu/hr. (INCLUDES FITTINGS)			
LENGTH OF PIPE - FEET	1/2 INCH	3/4 INCH	1 INCH
20	189,000	393,000	732,000
40	129,000	267,000	504,000
60	103,000	217,000	409,000

**WARNING:** Danger of property damage, bodily injury or loss of life. Never use a match or open flame to test for leaks. Never exceed specified pressures for testing. High pressures may damage the gas valve and cause over-firing which may result in heat exchanger failure. Liquid petroleum (L.P. Gas) is heavier than air and it will settle in any low area, including open depressions and it will remain there unless area is ventilated.

Never attempt startup of the unit before thoroughly ventilating area.

## ELECTRICAL CONNECTION

Refer to paragraph covering GAS AND ELECTRICAL SUPPLY OPENINGS, Page 10. Follow Wiring Diagrams, Pages 30 and 31.

If you have any doubt regarding the electrical hookup, or compliance with code or ordinance, consult your electrical inspector or a licensed electrician.

## HELPFUL HINT

After wire nuts are screwed to wires, a small strip of electrical tape can be applied over wire nut at its base and onto wires to make a very solid connection.

# Installing Your Furnace

## GROUNDING

The appliance when installed must be electrically grounded in accordance with local codes and ordinances or in their absence, with National Electrical Code (ANSI/NFPA 70) or Canadian Electrical Code (CSA C22.1) if an external electrical source is utilized. This appliance is equipped with three-prong (grounding) plug for your protection against shock hazard and should be plugged directly into a properly grounded three-prong receptacle. Do not cut or remove the grounding prong from this plug.

A ground lug is installed for the ground connection. Use a copper conductor (#AWG) from the unit to a grounded connection in the electric service panel or a properly driven and electrically grounded ground rod.

## ELECTRICAL POWER SUPPLY

Remove three-prong (grounding) service cord from the envelope parts package to be installed in the furnace. Remove 7/8 inch diameter (22mm) knockout at the left or right bottom side panel to route the three-prong service cord to an electrical outlet.

1. Insert the nylon cap attached to the end of the three-prong service cord thru the 7/8-inch diameter knockout into the burner control assembly area and insert it into the nylon plug attached to the outer casing bottom. If desired, you may route the thermostat wire alongside of the service cord and thru the same opening or choose another entry into the burner control assembly area.
2. Attach 7/8-inch diameter strain relief around the three-prong service cord and thermostat wire (if thermostat wire is routed thru the knockout). Insert the 7/8-inch strain relief into the 7/8-inch hole in the side panel of furnace.

## Replacement Part Listing:

Description	Part number
Service cord	P323335

**WARNING:** Do not insert the three-prong (grounding) service cord inside the burner control assembly area more than 10 inches (245mm). This could cause damage to the electrical cord resulting in electrical shock hazard and/or fire.

A branch circuit including this furnace must not exceed 15 Amperes. Run a separate 115V, 60Hz, 15 Ampere circuit from a separate circuit breaker or fuse in your service panel.

## WALL THERMOSTAT WIRING

Run thermostat wire to the furnace. Connect thermostat to the two wires marked "Thermostat" extending from top of furnace, using two wire nuts provided. See Wiring Diagrams on Pages 30 and 31. Refer to Page 13, Fig. 16 also.

Replace the fan to the original position on the motor shaft, and tighten securely. Replace the fan shroud, making sure it is centered vertically on the fan.

Tighten the screws securely.

Replace the top front panel and secure with thumbscrew.

**COMPLETE WIRING DIAGRAMS ON PAGES 30 AND 31.**

# Installing Your Furnace

## Start-Up Procedure

Start the furnace using the procedures in the section "OPERATING YOUR FURNACE".

**WARNING:** Danger of bodily injury or death. Liquefied petroleum gas (L.P. Gas) is heavier than air and it will settle in any low area, including open depressions and it will remain there unless the area is ventilated.

Never attempt to start-up the unit before thoroughly ventilating area.

Check the furnace operation as outlined in the following instructions. If any sparking, odors or unusual noises are encountered, shut off electric power immediately. Recheck for wiring errors or obstructions in or near fan motor.

### CHECK GAS INPUT AND PRESSURES

For furnaces located at elevations between sea level and 2,000 feet, the measured input must not be greater than the input shown on the rating plate of the furnace. For elevations above 2,000 feet, the measured input must not exceed the input on the rating plate reduced by 4 percent for each 1,000 feet that the furnace is above sea level.

The gas supply pressure and manifold pressure with the burners operating is specified on the rating plate.

Type of Gas	Manifold Pressure, In. W.C.
Natural	4.0
L.P.	10.0

Rated input will be obtained on a heating value of 2,500 Btu/hr. for propane at 10-inches manifold pressure with factory-sized orifices. If L.P. Gas having a different heating value is supplied, orifices must be changed by a qualified service technician before the furnace is operated.

### CHECK THERMOSTAT

Check thermostat operation. When set above room temperature shown on the thermostat, the main burner should light. Make certain the thermostat turns off the furnace when the room temperature reaches the selected setting and starts the furnace when room temperature falls a few degrees.

### ADJUST PILOT BURNER (STANDING PILOT MODELS ONLY)

Pilot flame should surround 5/8-inch to 1/2-inch of the thermocouple tip. To adjust, remove the cap from the pilot adjustment screw on gas valve. Turn screw counterclockwise to increase the flame, clockwise to decrease. Replace cap. Refer to Page 29, Fig. 30.

### CHECK THE MANIFOLD GAS PRESSURE

A tapped opening is provided in the gas valve to facilitate measuring the manifold gas pressure. A "U Tube" manometer having a scale range from 0 to 12-inches of water should be used for this measurement. The manifold pressure must be measured with the burner and pilot operating. Any major changes in flow must be made by changing the size of the burner orifice.

Check with your local gas supplier for proper orifice sizing.

### CHECK THE GAS INPUT (NATURAL GAS ONLY)

**WARNING:** Natural gas heating value (Btu per cubic foot) can vary significantly. Therefore, it is the installer's responsibility to see that Btu/hr. input to the furnace is adjusted properly. Failure to do so could cause combustion chamber failure, asphyxiation, fire or explosion resulting in damage, bodily injury or death. Refer to the National Fuel Gas Code (NFPA 54) to be sure the furnace is burning fuel at the proper rate.

Under firing could cause inadequate heat, excessive condensation or ignition problems. Over firing could cause sooting, flame impingement or overheating of the heat exchanger.

Before starting natural gas input check, obtain heating value of gas (BTU per cubic foot) at standard conditions from your local supplier. This factor is used in "Check the Gas Input" section and procedure.

To measure the input, using the gas meter, proceed as follows:

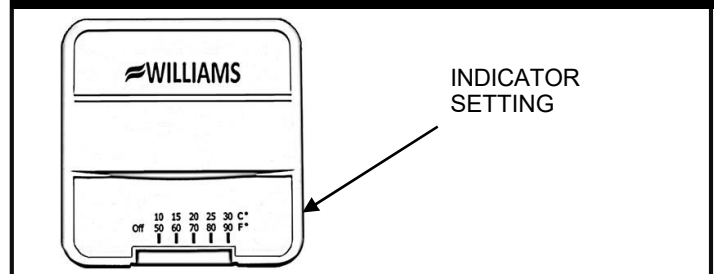
- Turn off gas supply to all other appliances except the furnace.
- With the furnace operating, time the smallest dial on the meter for one complete revolution. If this is a 2-cubic-foot dial, divide the seconds by 2. If it is a 1-cubic-foot dial, use the time in seconds as is. This gives the seconds per cubic foot of gas being delivered to the furnace.
- Assuming natural gas with a heating value of 1,000 Btu per cubic foot and 34-seconds per cubic foot used as determined by step (2), then:  

$$\text{Seconds per hour} = 3,600$$

$$\text{Input} = 1,000 \times 3,600 / 34 = 106,000 \text{ Btu/hr.}$$

This measured input must not be greater than the input indicated on the nameplate of the furnace.
- Relight all other appliances turned off in Step 1 above. Be sure all pilots are operating.

**FIGURE 27 Thermostat**



**WARNING:** Danger of bodily injury or death. Liquefied petroleum L.P. Gas is heavier than air and it will settle in any low area, including open depressions and it will remain there unless the area is ventilated.

# Operating Your Furnace

---

## Operating Your Furnace

---

### STANDING PILOT MODELS

4007732; 6007732; 4007731; 6007731

#### NOTE:

For models equipped with WILLIAMS gas valve P322041 or P322042 refer to this page and Page 23 for "SAFETY & LIGHTING INSTRUCTION" and "TURN GAS OFF TO APPLIANCE."

For models equipped with WILLIAMS gas valve P321704 or P321705 refer to this page and Page 24 for "SAFETY & LIGHTING INSTRUCTIONS" and "TURN GAS OFF TO APPLIANCE."

(All other models refer to page 25, 26 & 27.)

These furnaces are equipped with a manually operated Piezo spark igniter device to ignite the pilot gas. Follow the steps under "Lighting Instructions" (see Page 23 or Page 24) and use the manual spark igniter to light the pilot in Step 10. Press spark igniter button vigorously and repeatedly.

On new installations, the gas lines will be filled with air and it may take several minutes to establish the pilot flame.

Keep all access doors and panels in place except for inspection and maintenance.

**WARNING:** The surface of the furnace is hot during operation. Keep children, clothing, furniture, and flammable material away from it.

Do not store or use gasoline or other flammable liquids or vapors near the furnace.

### SAFETY CONTROLS

These furnace are protected against unsafe operation by four automatic safety controls: (1) A safety pilot acts to shut OFF the gas valve in case of pilot failure; (2) A redundant gas valve; (3) A limit switch shuts down the main burner to prevent overheating the furnace cabinet; this limit switch will reset when furnace cools; and (4) A thermal overload protects the motor against burnout caused by current surges or if anything should block the flow of air through the furnace. This switch will reset itself when the motor cools down and it cannot be adjusted.

**WARNING:** Danger of bodily injury or death.

Do not operate the furnace with a broken or missing pilot observation door.

**For models equipped with WILLIAMS gas valve P321704 or P321705.**

Models are equipped with a two-rate control valve. The rate knob on the gas valve is marked "LO" and "HI." Turn the rate knob to the "LO" position and the room thermostat will operate the main burner at about 70% of maximum capacity. Turn the rate knob to the "HI" position only when a fast heat-up is desired during extremely cold weather. High operation develops maximum capacity of the furnace.

**A two-speed fan is used with Models 6007732 and 6007731.**

Blower will operate at low speed then shift to high speed as the furnace heats up.

**WARNING:** Danger of property damage. Bodily injury or death

If the furnace overheats or fails to shut off, turn off the manual gas valve to the furnace before turning off the electric power.

# Operating Your Furnace

## FOR YOUR SAFETY, READ BEFORE LIGHTING

**WARNING:** If you do not follow these instructions exactly, a fire or explosion may result causing property damage, personal injury or loss of life.

- A. This appliance has a pilot which must be lighted by hand. When lighting the pilot, follow these instructions exactly.
- B. BEFORE LIGHTING smell around the appliance area for gas. Be sure to smell next to the floor because some gas is heavier than air and will settle on the floor.

### WHAT TO DO IF YOU SMELL GAS

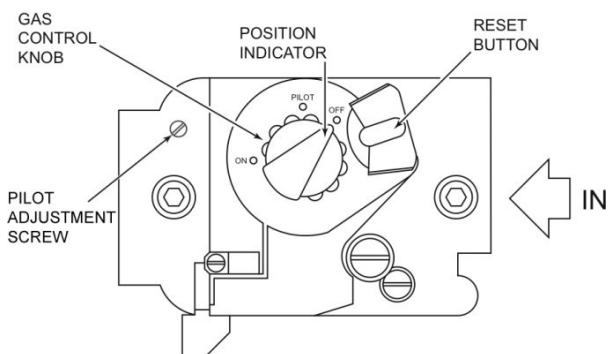
- Do not try to light any appliance or strike a match.
- Do not touch any electric switch; do not use any phone in your building.
- Immediately call your gas supplier from a neighbor's phone. Follow the gas supplier's instructions.

- If you cannot reach your gas supplier, call the fire department.
- C. Use only your hand to push in or turn the gas control knob. Never use tools. If the knob will not push in or turn by hand, don't try to repair it, call a qualified service technician. Force or attempted repair may result in a fire or explosion.
  - D. Do not use this appliance if any part has been under water. Immediately call a qualified service technician to inspect the appliance and to replace any part of the control system and any gas control which has been under water.

NOTE: FOR ADDITIONAL INFORMATION REFER TO THE INSTALLATION AND OPERATION INSTRUCTION MANUAL SUPPLIED WITH THIS APPLIANCE OR CONTACT THE MANUFACTURER IDENTIFYING THE PRODUCT BY ITS MODEL NUMBER LOCATED ON THE RATING PLATE, FOUND NEAR THE GAS VALVE.

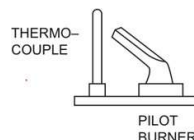
## LIGHTING INSTRUCTIONS

1. STOP! Read the safety information above.
2. Set the thermostat to lowest setting.
3. Turn off all electric power to the appliance.
4. Remove control access panel.
5. Turn the gas control knob clockwise ↻ to "OFF".



6. Wait five (5) minutes to clear out any gas, then smell for gas, including near the floor. **If you then smell gas, stop!** Follow "B" in the safety information above. If you don't smell gas, go to the next step.
7. Loosen wing nut and open pilot observation door (if equipped).
8. To find the pilot, follow the metal tube from the gas control valve. The pilot is mounted on the side of the burner.

9. Turn knob on gas control counterclockwise ↻ to "PILOT."



10. Push in the red reset button all the way and hold in. Immediately light the pilot. Continue to hold the red reset button in for about (1) minute after the pilot is lit. Release button and it will pop back up. Pilot should remain lit. If it goes out, repeat steps 5 through 10.
  - If button does not pop up when released, stop and immediately call your service technician or gas supplier.
  - If the pilot will not stay lit after several tries, turn the gas control knob to "OFF" and call your service technician or gas supplier.
11. Close the pilot observation door and tighten wing nut (if equipped).
12. Turn gas control knob counterclockwise ↻ to "ON". The knob can be turned to "ON" only if red reset button is up.
13. Replace the control access panel.
14. Turn on all electric power to the appliance.
15. Set thermostat to the desired setting.

## TO TURN OFF GAS TO APPLIANCE

1. Set the thermostat to lowest setting.
2. Turn off all electric power to the appliance if service is to be performed (if applicable).
3. Remove the control access panel.
4. Push in the gas control knob slightly and turn it clockwise to "OFF". Do not Force.
5. Replace the control access panel.

**IMPORTANT:** KEEP BURNER AND CONTROL COMPARTMENT CLEAN.

**WARNING:** DUE TO HIGH SURFACE TEMPERATURES - KEEP CHILDREN, CLOTHING, FURNITURE OR ANY COMBUSTIBLE MATERIAL AWAY FROM THE FURNACE.

# Operating Your Furnace

## FOR YOUR SAFETY, READ BEFORE LIGHTING

**WARNING:** If you do not follow these instructions exactly, a fire or explosion may result causing property damage, personal injury or loss of life.

- This appliance has a pilot which must be lighted by hand. When lighting the pilot, follow these Instructions exactly.
- BEFORE LIGHTING smell around the appliance area for gas. Be sure to smell next to the floor because some gas is heavier than air and will settle on the floor.

### WHAT TO DO IF YOU SMELL GAS

- Do not try to light any appliance or strike a match.
- Do not touch any electric switch; do not use any phone in your building.
- Immediately call your gas supplier from a neighbor's phone. Follow the gas supplier's instructions.

- If you cannot reach your gas supplier, call the fire department.

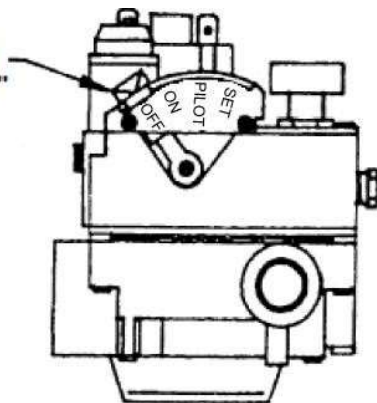
- Use only your hand to push in or turn the gas control knob. Never use tools. If the knob will not push in or turn by hand, don't try to repair it, call a qualified service technician. Force or attempted repair may result in a fire or explosion.
- Do not use this appliance if any part has been under water. Immediately call a qualified service technician to inspect the appliance and to replace any part of the control system and any gas control which has been under water.

NOTE: FOR ADDITIONAL INFORMATION REFER TO THE INSTALLATION AND OPERATION INSTRUCTION MANUAL SUPPLIED WITH THIS APPLIANCE OR CONTACT THE MANUFACTURER IDENTIFYING THE PRODUCT BY ITS MODEL NUMBER LOCATED ON THE RATING PLATE, FOUND NEAR THE GAS VALVE.

## LIGHTING INSTRUCTIONS

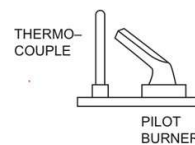
- STOP! Read the safety information above.
- Set the thermostat to its lowest setting.
- Turn off all electric power to the appliance.
- Remove control access panel.
- From the "ON" position, depress and move selector arm on gas control to the "OFF" position. Do not force.

GAS CONTROL  
SELECTOR ARM  
SHOWN IN "OFF"  
POSITION



- Wait five (5) minutes to clear out any gas, then smell for gas, including near the floor. **If you then smell gas, stop!** Follow "B" In the safety information above. If you don't smell gas, go to the next step.
- Loosen wing nut and open pilot observation door (if equipped).

- To find the pilot, follow the metal tube from the gas control valve. The pilot is mounted on the side of the burner.
- Hold lighted match at the pilot burner.



- Move selector arm to the "SET" position and light the pilot. Hold in "SET" position for 1/2 minute after pilot is lit.

NOTE: Sufficient time must be allowed for pilot flame to heat thermocouple and hold safety magnet in locked-up position. Also, time must be allowed for air to be purged from gas lines during first starting operation.

- Release the selector arm, and if the pilot remains lit, move the selector arm to the "ON" position.
  - If the pilot will not stay lit after several tries, move the selector arm to the "OFF" and call your service technician or gas supplier.
- Close the pilot observation door and tighten wing nut (if equipped).
- Replace the control access panel.
- Turn on all electric power to the appliance.
- Set thermostat to the desired setting.

## TO TURN OFF GAS TO APPLIANCE

- Set the thermostat to the lowest setting.
- Turn off all electric power to the appliance if service is to be performed.
- Remove the control access panel.
- From the "ON" position, depress and move selector arm on gas control to the "OFF" position. Do not force the control selector arm.
- Replace the control access panel.

**IMPORTANT:** KEEP BURNER AND CONTROL COMPARTMENT CLEAN..



# Operating Your Furnace

**WARNING:** DUE TO HIGH SURFACE TEMPERATURES - KEEP CHILDREN, CLOTHING, FURNITURE OR ANY COMBUSTIBLE MATERIAL AWAY FROM THE FURNACE.

## ELECTRONIC IGNITION MODELS

4007332; 5507332; 4007331; 5507331

### NOTE:

For models equipped with WILLIAMS gas valve P322043 or P322044 refer to this page and Page 26 for "SAFETY & LIGHTING INSTRUCTION" and "TURN GAS OFF TO APPLIANCE." For models equipped with WILLIAMS gas valve P321897 or P321898 refer to this page and page 27 for "SAFETY & LIGHTING INSTRUCTION" and "TURN GAS OFF TO APPLIANCE."

(All other models refer to page 22, 23 & 24.)

### THE FURNACE WORKS LIKE THIS:

1. The thermostat turns on the control module.
2. Automatic relight system (in the module) opens the gas valve and electronically ignites the pilot. After the pilot flame has been established and proven by the control module, the main gas valve circuit opens and the pilot lights the main burners.
3. Heat builds up in the furnace and starts the fan. The heated air comes out the front bottom louvered panel at floor level.
4. When the thermostat setting is reached, it shuts off the main burner.
5. The fan runs until the heat is removed from the furnace, then it turns off.

### IMPORTANT

KEEP BURNER AND CONTROL COMPARTMENT CLEAN.

### SAFETY LIMIT CONTROL

These furnaces are protected against unsafe operation by three automatic safety controls: (1) The electronic ignition system. (2) A limit switch shuts down the main burner to prevent overheating of the furnace cabinet. This limit switch will reset when furnace cools. (3) A thermal overload switch protects the motor against burnout caused by current surges or if anything should block the flow of air through the furnace. The switch will turn the main burner off. When motor cools down, this switch will reset itself. This switch cannot be adjusted.

**WARNING:** The surface of the furnace is hot during operation. Keep children, clothing, furniture, and flammable material away from it.

Do not store or use gasoline or other flammable liquids or vapors near the furnace.

**WARNING:** Danger of bodily injury or death.

Do not operate the furnace with a broken or missing pilot observation door.

**A two-speed fan is used with models: 5507331 and 5507332.**

Blower will first operate at low speed then shift to high speed as the furnace heats up.

**WARNING:** Danger of property damage, bodily injury or death. If the furnace overheats or fails to shut off, turn off the manual gas valve to the furnace before turning off electric power.

# Operating Your Furnace

## FOR YOUR SAFETY, READ BEFORE LIGHTING

**WARNING:** If you do not follow these instructions exactly, a fire or explosion may result causing property damage, personal injury or loss of life.

- A. This appliance is equipped with an ignition device which automatically lights the pilot. Do not try to light the pilot by hand.
- B. BEFORE LIGHTING smell around the appliance area for gas. Be sure to smell next to the floor because some gas is heavier than air and will settle on the floor.

### WHAT TO DO IF YOU SMELL GAS


- Do not try to light any appliance or strike a match.
- Do not touch any electric switch; do not use any phone in your building.
- Immediately call your gas supplier from a neighbor's phone. Follow the gas supplier's instructions.

- If you cannot reach your gas supplier, call the fire department.

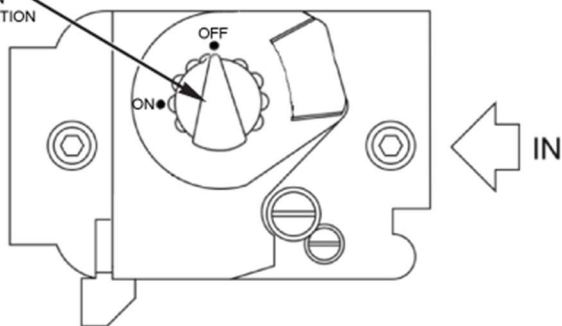
- C. Use only your hand to push in or turn the gas control knob. Never use tools. If the knob will not push in or turn by hand, don't try to repair it, call a qualified service technician. Force or attempted repair may result in a fire or explosion.
- D. Do not use this appliance if any part has been under water. Immediately call a qualified service technician to inspect the appliance and to replace any part of the control system and any gas control which has been under water.


NOTE: FOR ADDITIONAL INFORMATION REFER TO THE INSTALLATION AND OPERATION INSTRUCTION MANUAL SUPPLIED WITH THIS APPLIANCE OR CONTACT THE MANUFACTURER IDENTIFYING THE PRODUCT BY ITS MODEL NUMBER LOCATED ON THE RATING PLATE, FOUND NEAR THE GAS VALVE.

## LIGHTING INSTRUCTIONS

1. STOP! Read the safety information above.
2. Set the thermostat to its lowest setting.
3. Turn off all electric power to the appliance.
4. This appliance is equipped with an ignition device which automatically lights the pilot. Do not try to light the pilot by hand.
5. Remove the control access panel.
6. Turn the gas control knob clockwise  to "OFF".

GAS CONTROL  
KNOB SHOWN  
IN "OFF" POSITION



7. Wait five (5) minutes to clear out any gas, then smell for gas, including near the floor. **If you smell gas, stop!** Follow "B" in the safety information above. If you don't smell gas, go to the next step.
8. Turn the gas control knob counterclockwise  to "ON".
9. Replace the control access panel.
10. Turn on all electric power to the appliance.
11. Turn the thermostat to the "ON" (HEAT) position. Set the thermostat higher than room temperature. The pilot will automatically light and the main burner(s) will light in approximately 45 seconds.

NOTE: On initial start-up or after prolonged shut down, several ignition cycles may be required to purge the gas lines. To accomplish the recycle - repeat steps 6 through 11 until the pilot is established.

12. Set the thermostat to the desired setting.
13. After the room thermostat turns the system off, a delay of approximately one minute is required before the system can be turned on again.
14. If the appliance will not operate, follow the instructions "To Turn Off Gas To Appliance" and call your service technician or gas supplier.

## TO TURN OFF GAS TO APPLIANCE

1. Set the thermostat to its lowest setting.
2. Turn off all electric power to the appliance if service is to be performed.
3. Remove the control access panel.
4. Push in the gas control knob slightly and turn it clockwise to "OFF". Do not force the gas control knob.
5. Replace the control access panel.

**IMPORTANT:** KEEP BURNER AND CONTROL COMPARTMENT CLEAN.

**WARNING:** DUE TO HIGH SURFACE TEMPERATURES - KEEP CHILDREN, CLOTHING, FURNITURE OR ANY COMBUSTIBLE MATERIAL AWAY FROM THE FURNACE.

# Operating Your Furnace

## FOR YOUR SAFETY, READ BEFORE LIGHTING

**WARNING:** If you do not follow these instructions exactly, a fire or explosion may result causing property damage, personal injury or loss of life.

- A. This appliance is equipped with an ignition device which automatically lights the pilot. Do not try to light the pilot by hand.
- B. BEFORE LIGHTING smell around the appliance area for gas. Be sure to smell next to the floor because some gas is heavier than air and will settle on the floor.

### WHAT TO DO IF YOU SMELL GAS

- Do not try to light any appliance or strike a match.
- Do not touch any electric switch; do not use any phone in your building.
- Immediately call your gas supplier from a neighbor's phone. Follow the gas supplier's instructions.

- If you cannot reach your gas supplier, call the fire department.

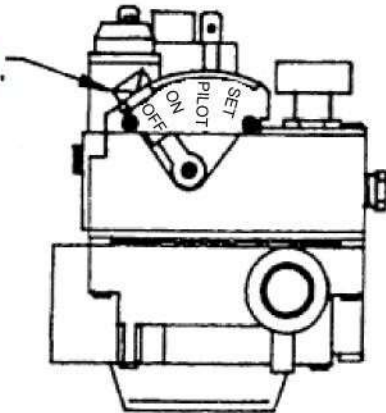
- C. Use only your hand to push in or turn the gas control knob. Never use tools. If the knob will not push in or turn by hand, don't try to repair it, call a qualified service technician. Force or attempted repair may result in a fire or explosion.
- D. Do not use this appliance if any part has been under water. Immediately call a qualified service technician to inspect the appliance and to replace any part of the control system and any gas control which has been under water.

NOTE: FOR ADDITIONAL INFORMATION REFER TO THE INSTALLATION AND OPERATION INSTRUCTION MANUAL SUPPLIED WITH THIS APPLIANCE OR CONTACT THE MANUFACTURER IDENTIFYING THE PRODUCT BY ITS MODEL NUMBER LOCATED ON THE RATING PLATE, FOUND NEAR THE GAS VALVE.

## LIGHTING INSTRUCTIONS

1. STOP! Read the safety information above.
2. Set the thermostat to lowest its setting.
3. Turn off all electric power to the appliance.
4. This appliance is equipped with an ignition device which automatically lights the pilot. Do not try to light the pilot by hand.
5. Remove the control access panel.
6. From the "ON" position, depress and move the selector arm on gas control to the "OFF" position. Do not force.

GAS CONTROL  
SELECTOR ARM  
SHOWN IN "OFF"  
POSITION



7. Wait five (5) minutes to clear out any gas, then smell for gas, including near the floor. **If you smell gas, stop!** Follow "B" In the safety information above. If you don't smell gas, go to the next step.
8. Move the selector arm to the "ON" position.
9. Replace the control access panel.
10. Turn on all electric power to the appliance.
11. Turn the thermostat to the "ON" (HEAT) position. Set the thermostat higher than room temperature. The pilot will automatically light and main burner(s) will light in approximately 45 seconds.

NOTE: On initial start-up or after prolonged shut down, several ignition cycles may be required to purge gas lines. To accomplish the recycle - repeat steps 6 through 11 until the pilot is established.

12. Set thermostat to the desired setting.
13. After the room thermostat turns the system off, a delay of approximately one minute is required before the system can be turned on again.
14. If the appliance will not operate, follow the instructions "To Turn Off Gas To Appliance" and call your service technician or gas supplier.

## TO TURN OFF GAS TO APPLIANCE

1. Set the thermostat to its lowest setting.
2. Turn off all electric power to the appliance if service is to be performed.
3. Remove the control access panel.
4. From the "ON" position, depress and move the selector arm on gas control to the "OFF" position. Do not force the selector arm.
5. Replace the control access panel.

**IMPORTANT:** KEEP BURNER AND CONTROL COMPARTMENT CLEAN.

**WARNING:** DUE TO HIGH SURFACE TEMPERATURES - KEEP CHILDREN, CLOTHING, FURNITURE OR ANY COMBUSTIBLE MATERIAL AWAY FROM THE FURNACE.

# Caring for Your Furnace

## How To Care For Your Furnace

**WARNING:** Danger of bodily injury or death. Turn off electric power supply at the disconnect switch, fuse box or service panel before removing any doors or access or service panels from the unit.

### CABINET FINISH

Clean the cabinet with damp rag. Never use abrasive cleaners. Cabinets are finished in a heat resistant powder coat finish - DO NOT refinish with wall paint.

### COMBUSTION AND VENTILATION AIR

The combustion and ventilation air supply must not be blocked.

Do not put anything in or on the furnace cabinet.

For better circulation and more effective heating, do not place obstructive furniture closer than four feet to the front of the cabinet or two feet to either side of the cabinet.

### FURNACE AREA

Keep the area near the furnace clear and free from combustible materials, gasoline, and other flammable liquids and vapors.

### ANNUAL UPKEEP NEEDED

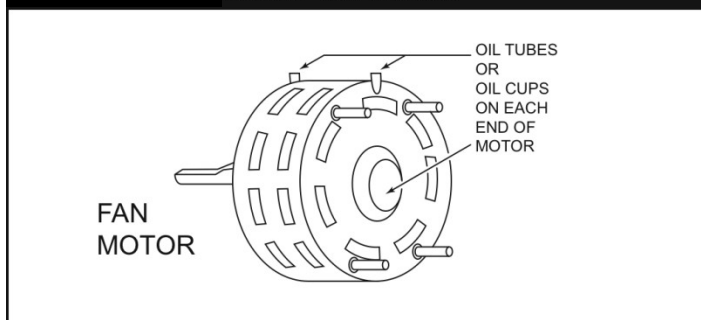
It is recommended that a qualified service technician perform these checks at the beginning of each heating season.

### CLEANING AND OILING

Shut off electricity, and then remove cabinet door and front panel. Clean any lint or dirt from fan blades, fan motor, and exposed air passages. Use a brush.

Put 5 drops of SAE 20 oil in each of the two cups or oil tubes on the fan motor, See Fig. 28, below.

**FIGURE 28 Motor Oil Holes**



### PILOT BURNER

Light the pilot using instructions in OPERATING YOUR FURNACE (pages 22 thru 27, depending on your model). Leave thermostat at lowest setting.

The pilot flame should surround the thermocouple tip 5/8 to 1/2-inch. Refer to Page 29, Fig. 30. If the flame needs adjusting, do it as follows:

### ADJUST PILOT BURNER (Page 28, Fig 29 & Page 29, Fig 30)

1. Remove the screw cover over pilot adjusting screw.
2. Insert small screwdriver, adjust the flame as needed. Turn the screw counterclockwise to increase the flame, clockwise to decrease.
3. Turn the thermostat to its highest setting. The main burners should light quickly and smoothly. Turn the thermostat to its lowest setting. Main burners should go out. The pilot should remain lit except for electronic ignition models. See Page 22.

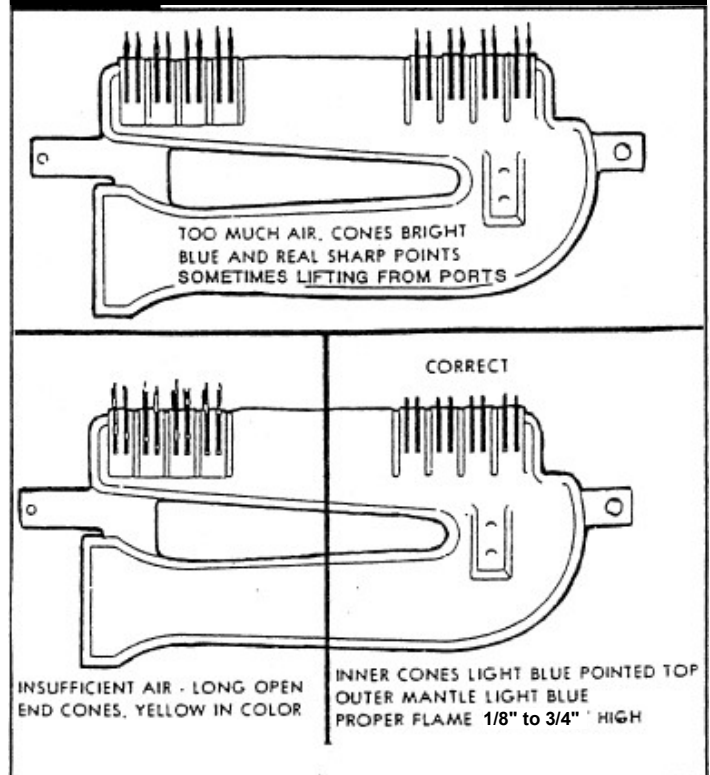
### BURNER FLAME

Start the furnace and let it operate about 10 minutes then look at the burner flame. Flames should be soft and blue, see Fig. 29. If flames appear abnormal, contact the gas company or a qualified service technician immediately.

### VENTING SYSTEM

Make sure that no parts of the vent air system are blocked, rusted or damaged (including joint gaskets). Clean or replace before using furnace. See Page 14 and 15 for proper assembly and resealing of vent-air system.

**FIGURE 29 Main Burner Flame Pattern**



# Caring for Your Furnace

## How To Care For Your Furnace

### BURNER CLEANING

Check burner. If cleaning is required, contact a qualified service technician to clean and service the burner.

**WARNING:** Danger of bodily injury or death. Make sure electric power and gas supply are off before removing panels or doors.

Disconnect the gas line inside the cabinet.

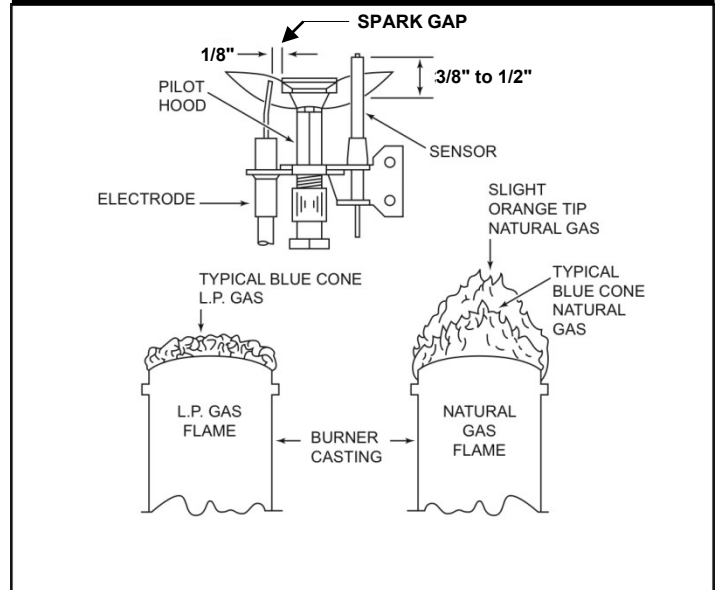
Remove three screws from the front of the combustion chamber bottom panel and drop the assembly down. Clean inside the combustion chamber and the burner with a shop type vacuum cleaner.

To remove burners remove screw from the end of the burner and slide the burner out of its bracket (it may be necessary to slightly spring the bracket).

Inspect the Burner Box gasket. Replace if damaged.

Replace burner assembly and control assembly by reversing the above procedures.

**FIGURE 30 Pilot Flame & Spark Gap**



Check the spark gap. It must be carefully adjusted to specifications, as illustrated (Fig. 30), for the ignition device to function properly.

## Furnace Technical information

Furnace Technical Information						
Model Number	Gas Type	** Rating in Btu/hr.		Main Burner Orifice		
		Input	HTG CAPAC.	DRILL	DEC.	QTY.
4007332	NATURAL	40,000	31,732	#32	.1160	1
4007331	L.P.	40,000	32,356	#48	.0760	1
4007732	NATURAL	40,000	32,216	#32	.1160	1
4007731	L.P.	40,000	32,275	#48	.0760	1
5507332	NATURAL	55,000	42,231	#41	.0960	2
5507331	L.P.	55,000	44,589	#52	.0630	2
6007732	NATURAL	60,000	47,059	#38	.1010	2
6007731	L.P.	60,000	47,167	N/A	.0640	2

The efficiency rating of these appliances is a product of a thermal efficiency rating system determined under continuous operating conditions and was determined independently of any installed system.

\*\*For elevations above 2,000 feet reduce ratings 4% for each 1,000 feet above sea level.

\*\*Btu/hr. = British Thermal Units per hour.

# Wiring Diagrams

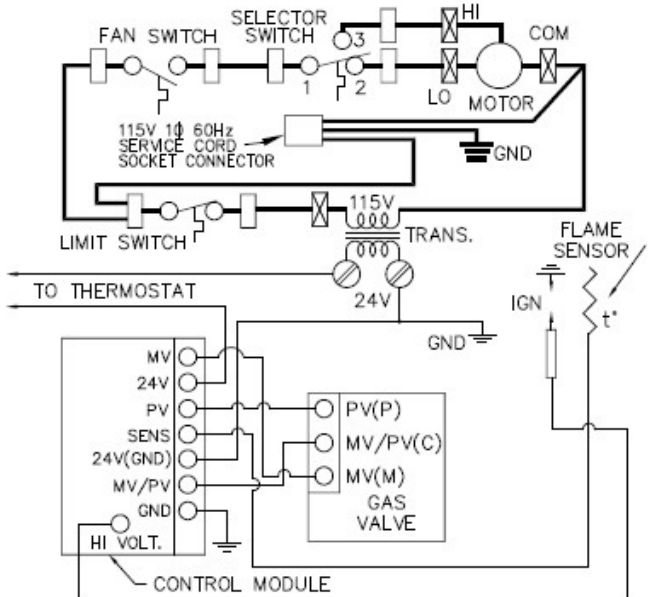
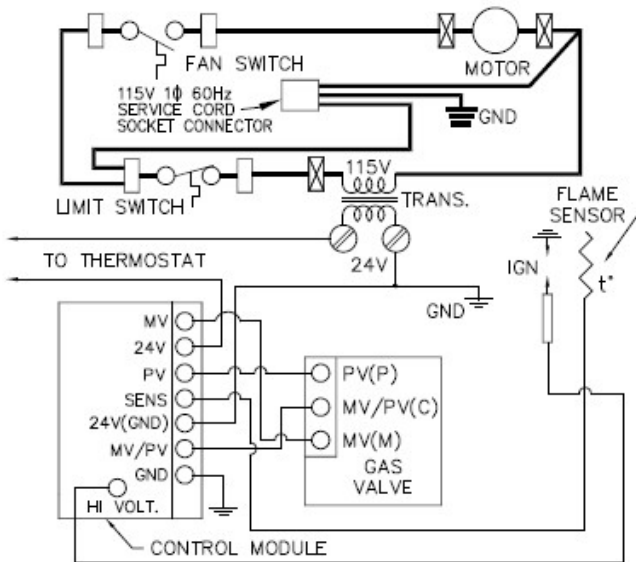
## Wiring Diagrams

### MODELS - 4007332 /4007331

### MODELS - 5507332 /5507331

FOR 40M Btu/hr. FAN TYPE VENTED WALL FURNACE WITH INTERMITTENT IGNITION CONTROL SYSTEM

FOR 55M Btu/hr. FAN TYPE VENTED WALL FURNACE WITH INTERMITTENT IGNITION CONTROL SYSTEM



**LEGEND**

- FACTORY WIRED LINE VOLTAGE.
- FACTORY WIRED LOW VOLTAGE.
- 1/4 QUICK CONNECT TERMINAL FOR FACTORY WIRING.
- ⊗ WIRE CONNECTOR FOR FACTORY WIRING LINE VOLTAGE.
- ⊙ SCREW TERMINAL LOW VOLTAGE.
- FACTORY WIRED CONNECTION

**NOTES:**

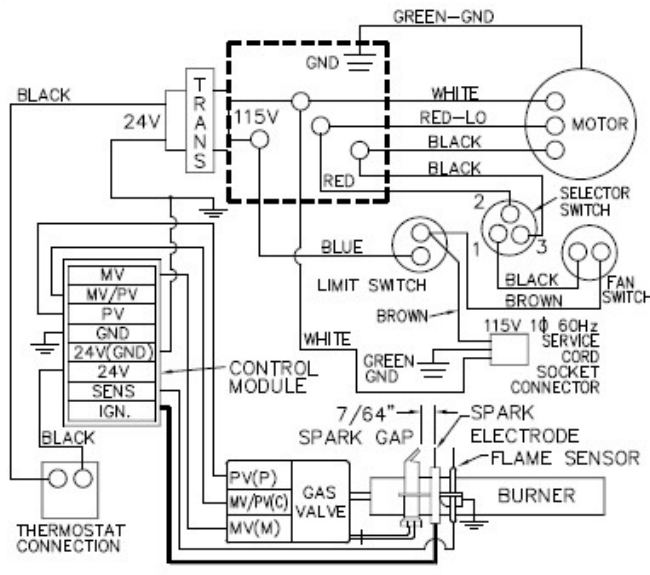
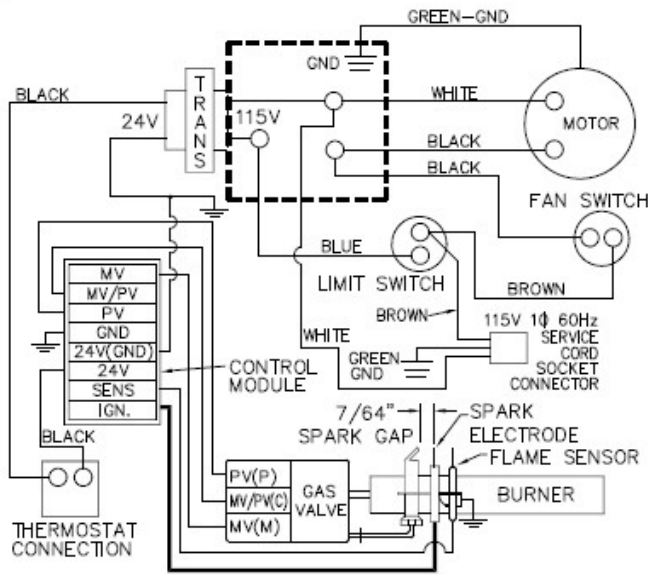
1. IF ANY OF THE ORIGINAL WIRE AS SUPPLIED WITH THE APPLIANCE MUST BE REPLACED, IT MUST BE REPLACED WITH TYPE AWM 105°C, 18 GA. WIRE 4/64 INSULATION OR EQUIVALENT.
2. MOTOR IS THERMALLY OVERLOAD PROTECTED, 115V, 1φ 60Hz.—LESS THAN 3 AMPS.

**LEGEND**

- FACTORY WIRED LINE VOLTAGE.
- FACTORY WIRED LOW VOLTAGE.
- 1/4 QUICK CONNECT TERMINAL FOR FACTORY WIRING.
- ⊗ WIRE CONNECTOR FOR FACTORY WIRING LINE VOLTAGE.
- ⊙ SCREW TERMINAL LOW VOLTAGE.
- FACTORY WIRED CONNECTION

**NOTES:**

1. IF ANY OF THE ORIGINAL WIRE AS SUPPLIED WITH THE APPLIANCE MUST BE REPLACED, IT MUST BE REPLACED WITH TYPE AWM 105°C, 18 GA. WIRE 4/64 INSULATION OR EQUIVALENT.
2. MOTOR IS THERMALLY OVERLOAD PROTECTED, 115V, 1φ 60Hz.—LESS THAN 3 AMPS.

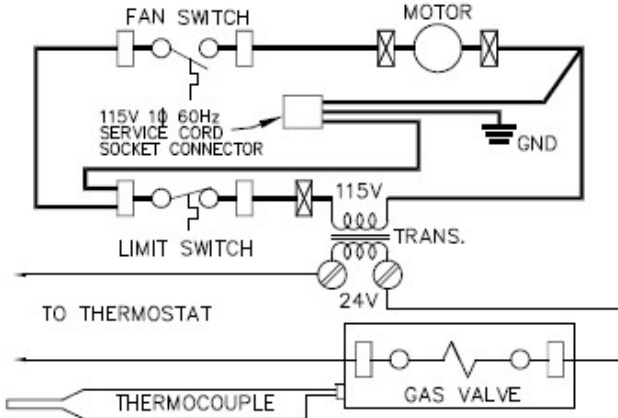


# Wiring Diagrams

## MODELS - 4007732/4007731

## MODELS - 6007732/6007731

FOR 40M Btu/hr. FAN TYPE VENTED WALL FURNACE WITH STANDING PILOT CONTROL SYSTEM



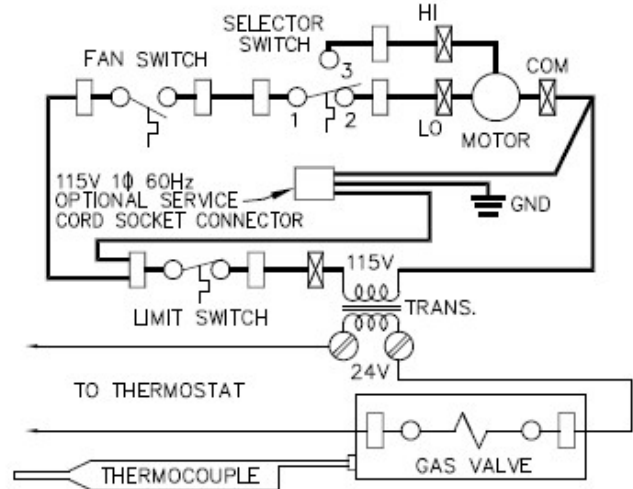
**LEGEND**

- FACTORY WIRED LINE VOLTAGE.
- FACTORY WIRED LOW VOLTAGE.
- 1/4 QUICK CONNECT TERMINAL FOR FACTORY WIRING.
- ⊗ WIRE CONNECTOR FOR FACTORY WIRING LINE VOLTAGE.
- ⊙ SCREW TERMINAL LOW VOLTAGE.
- FACTORY WIRED CONNECTION

**NOTES:**

1. IF ANY OF THE ORIGINAL WIRE AS SUPPLIED WITH THE APPLIANCE MUST BE REPLACED, IT MUST BE REPLACED WITH TYPE AWM 105°C, 18 GA. WIRE 4/64 INSULATION OR EQUIVALENT.
  2. MOTOR IS THERMALLY OVERLOAD PROTECTED.
- 115V, 1ϕ 60Hz.—LESS THAN 3 AMPS.

FOR 60M Btu/hr. FAN TYPE VENTED WALL FURNACE WITH STANDING PILOT CONTROL SYSTEM

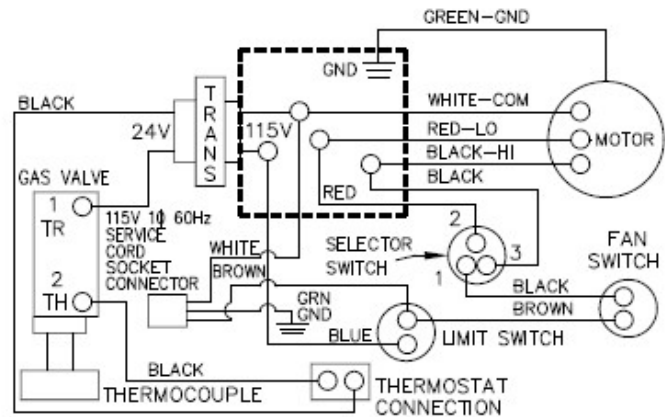
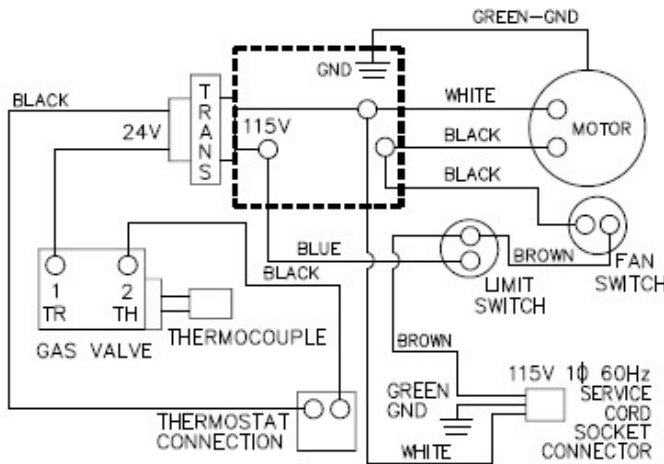


**LEGEND**

- FACTORY WIRED LINE VOLTAGE.
- FACTORY WIRED LOW VOLTAGE.
- 1/4 QUICK CONNECT TERMINAL FOR FACTORY WIRING.
- ⊗ WIRE CONNECTOR FOR FACTORY WIRING LINE VOLTAGE.
- ⊙ SCREW TERMINAL LOW VOLTAGE.
- FACTORY WIRED CONNECTION

**NOTES:**

1. IF ANY OF THE ORIGINAL WIRE AS SUPPLIED WITH THE APPLIANCE MUST BE REPLACED, IT MUST BE REPLACED WITH TYPE AWM 105°C, 18 GA. WIRE 4/64 INSULATION OR EQUIVALENT.
  2. MOTOR IS THERMALLY OVERLOAD PROTECTED.
- 115V, 1ϕ 60Hz.—LESS THAN 3 AMPS.

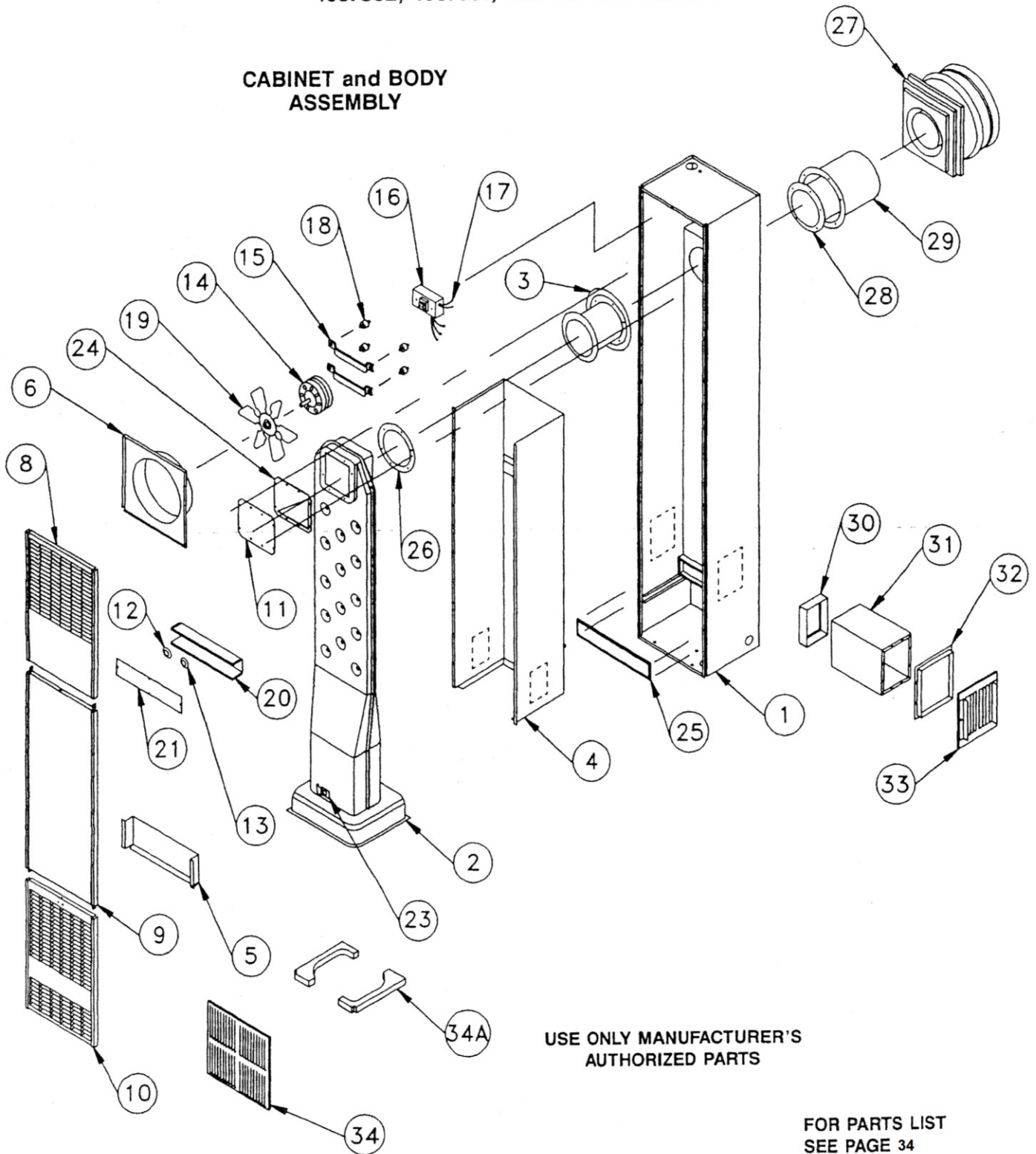


# Replacements Parts

## WILLIAMS DIRECT VENT GAS-FIRED WALL FURNACE

REPAIR PARTS FOR MODELS —  
4007332, 4007331, 4007732 and 4007731

### CABINET and BODY ASSEMBLY



USE ONLY MANUFACTURER'S  
AUTHORIZED PARTS

FOR PARTS LIST  
SEE PAGE 34





# Replacements Parts

## REPLACEMENT PARTS LIST FOR MODELS 4007332; 4007732; 4007331 and 4007731

Ref. Number	Description	PART NO. FOR MODEL			
		4007332	4007732	4007331	4007731
1	Outer Casing with Air Pan	11C42-2	11C42-2	11C42-2	11C42-2
2	Heating Element	11C67	11C67	11C67	11C67
3	Element Tube	11C37	11C37	11C37	11C37
4	Inner Liner	11B46	11B46	11B46	11B46
5	Deflector Baffle Handle	11C63	11C63	11C63	11C63
6	Fan Shroud	11B86	11B86	11B86	11B86
8	Top Front Panel	11B102	11B102	11B102	11B102
9	Center Front Panel	11C62	11C62	11C62	11C62
10	Bottom Front Panel	11B103	11B103	11B103	11B103
11	Element Face Cover	11A103	11A103	11A103	11A103
12	Limit Switch	P200300	P200300	P200300	P200300
13	Fan Switch	P200200	P200200	P200200	P200200
14	Motor	P151101	P151101	P151101	P151101
15	Motor Support (2 Req.)	7B46	7B46	7B46	7B46
16	Transformer	P024200	P024200	P024200	P024200
17	Internal Wires (Except Ignition Control Wires For Models 4007332 & 4007331)	11A152	11A152	11A152	11A152
18	Vibration Mounts (4 Req.)	P022800	P022800	P022800	P022800
19	Fan Blade	P200600	P200600	P200600	P200600
20	Switch Box	11B05	11B05	11B05	11B05
21	Switch Box Cover	11C68	11C68	11C68	11C68
23	Observation Door Asy	12B40	12B40	12B40	12B40
24	Element Face Gasket	P200900	P200900	P200900	P200900
25	Air Pan Tunnel Gasket	P151900	P151900	P151900	P151900
26	Seal Gasket	P103100	P103100	P103100	P103100
27	Vent Cap	11C09	11C09	11C09	11C09
28	Flue Extension	9802 Kit	11A217	11A217	11A217
29	Air Inlet Extension		11B144	11B144	11B144
*	* 4701 Trim Strip Kit	4701	4701	4701	4701
30 31 32	* Inner Boot * Outer Boot * Plaster Ground	6701 Side Outlet Kit 10" Boots	6701	6701	6701
33	* 6702 Side Casing Grille Kit		6702	6702	6702
34	* 6703 Diffusing Grille Kit - Two-Way * 6704 Diffusing Grille Kit - Two-Way		6703 6704	6703 6704	6703 6704
34A	Gasket, Burner Pan (2 Req.)	P321020	P321020	P321020	P321020
**	Owner's Manual	P321004	P321004	P321004	P321004

\* Not available separately, in kit form only.

\*\* Not Shown.

For part illustration, see page 32.

Note: Screws and bolts are standard hardware items, available locally.

# Replacements Parts

## REPLACEMENT PARTS LIST FOR MODELS 4007332; 4007732; 4007331 and 4007731

Ref. Number	Description	PART NO. FOR MODEL			
		4007332	4007732	4007331	4007731
35	Manifold	P323653	P323653	P323653	P323653
36	Manifold Gasket	P151700	P151700	P151700	P151700
37	Orifice Fitting, Specify Model & Gas	P090532	P090532	P090548	P090548
38	50mm Burner	P323648	P323648	P323648	P323648
39	Burner Pan	11B133	11B133	11B133	11B133
40	Valve, Williams Nat.	—	P323209	—	—
	Valve, Williams L.P.G.	—	—	—	P322042
	Valve, Williams Nat.	P323210	—	—	—
	Valve, Williams L.P.G.	—	—	P322044	—
41	Pilot, Nat.	P323418	P323418	—	—
	Pilot, L.P.G.	—	—	P323419	P323419
42	Thermocouple	—	P254000	—	P254000
	Flame Sensor	P271100	—	P271100	—
43	Pilot Tube Gasket	P151800	P151800	P151800	P151800
44	Pilot Tube Seal	11A41	11A41	11A41	11A41
45	Gasket - 44 inch	P101600	P101600	P101600	P101600
46	Thermostat	P322016	P322016	P322016	P322016
47	Ignition Control Unit	P321900	—	P321900	—
48	Piezo Gas Lighter	—	P285500	—	P285500
49	Ignition Shield	11B139	—	11B139	—
50	Manifold Adapter	P321887	P321888	P321887	P321888
**	Ignition Control Wires	31B036	—	31B036	—

\* Not available separately, in kit form only.

\*\* Not Shown.

For part illustration, see page 33.

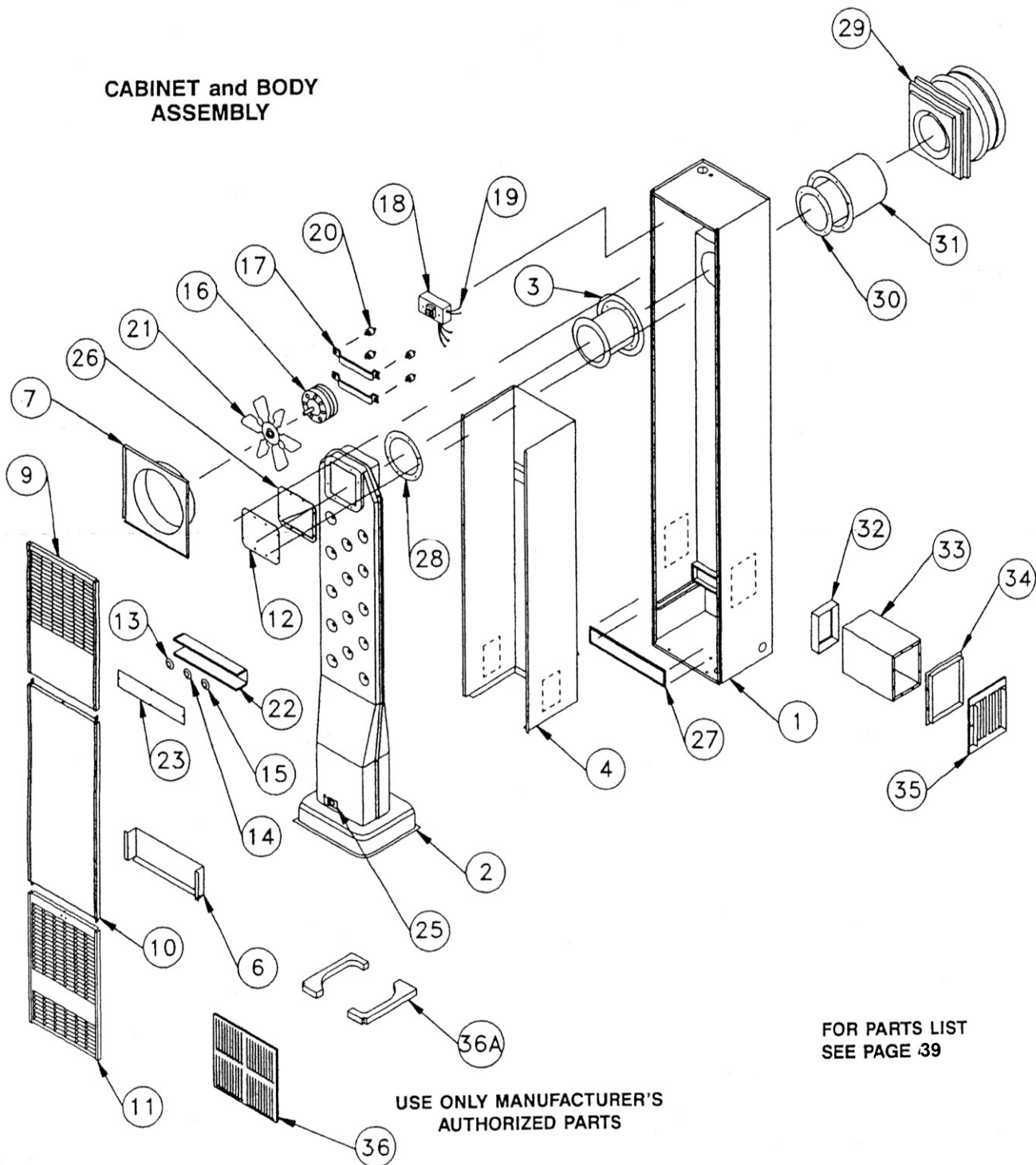
Note: Screws and bolts are standard hardware items, available locally.

# Replacements Parts

## WILLIAMS DIRECT VENT GAS-FIRED WALL FURNACE

### FURNACE ASSEMBLY FOR MODELS — 5507332 and 5507331

#### CABINET and BODY ASSEMBLY



FOR PARTS LIST  
SEE PAGE 39

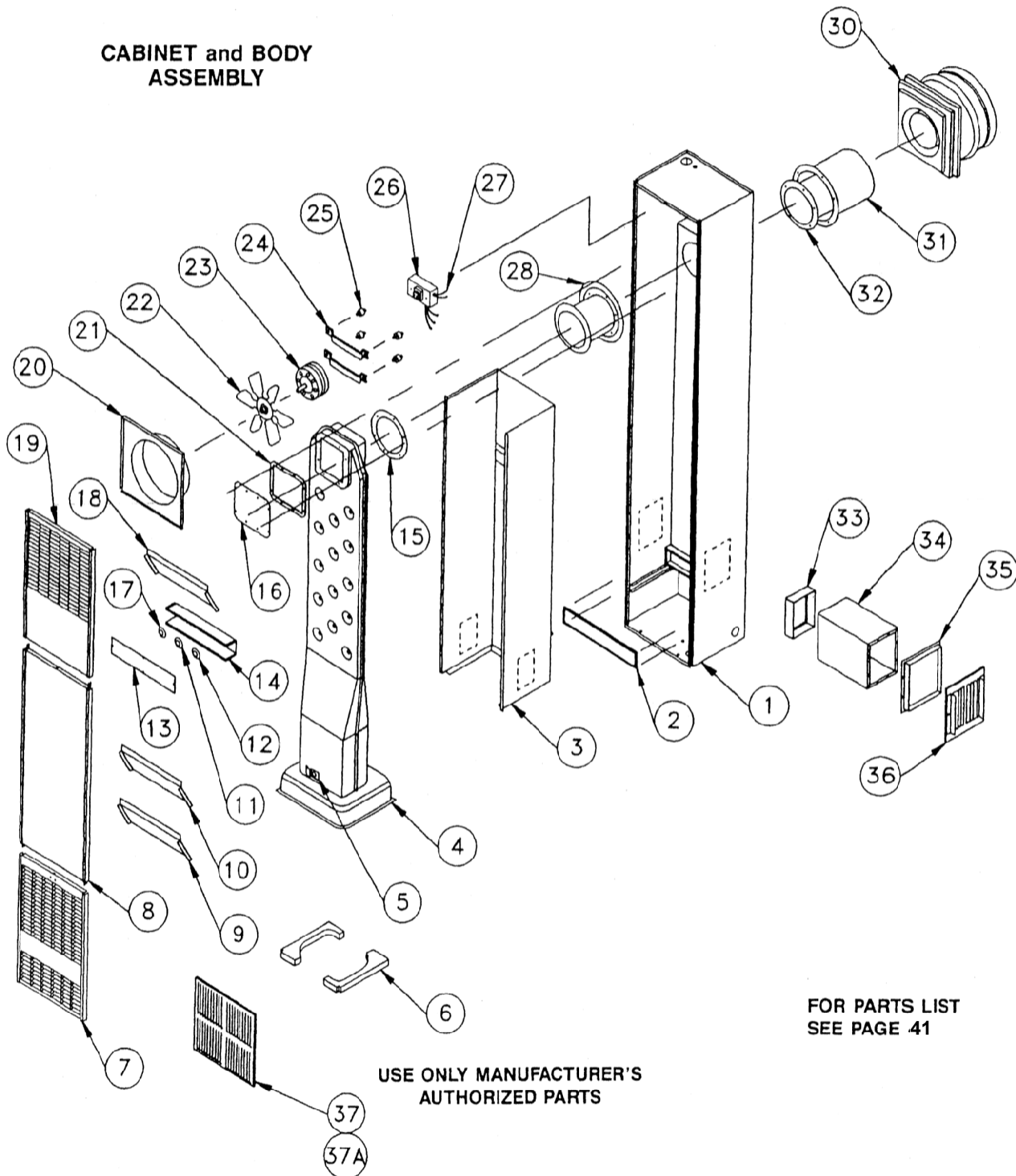
USE ONLY MANUFACTURER'S  
AUTHORIZED PARTS

# Replacements Parts

WILLIAMS DIRECT VENT GAS-FIRED WALL FURNACE

FURNACE ASSEMBLY FOR MODELS —  
6007732 and 6007731

CABINET and BODY  
ASSEMBLY

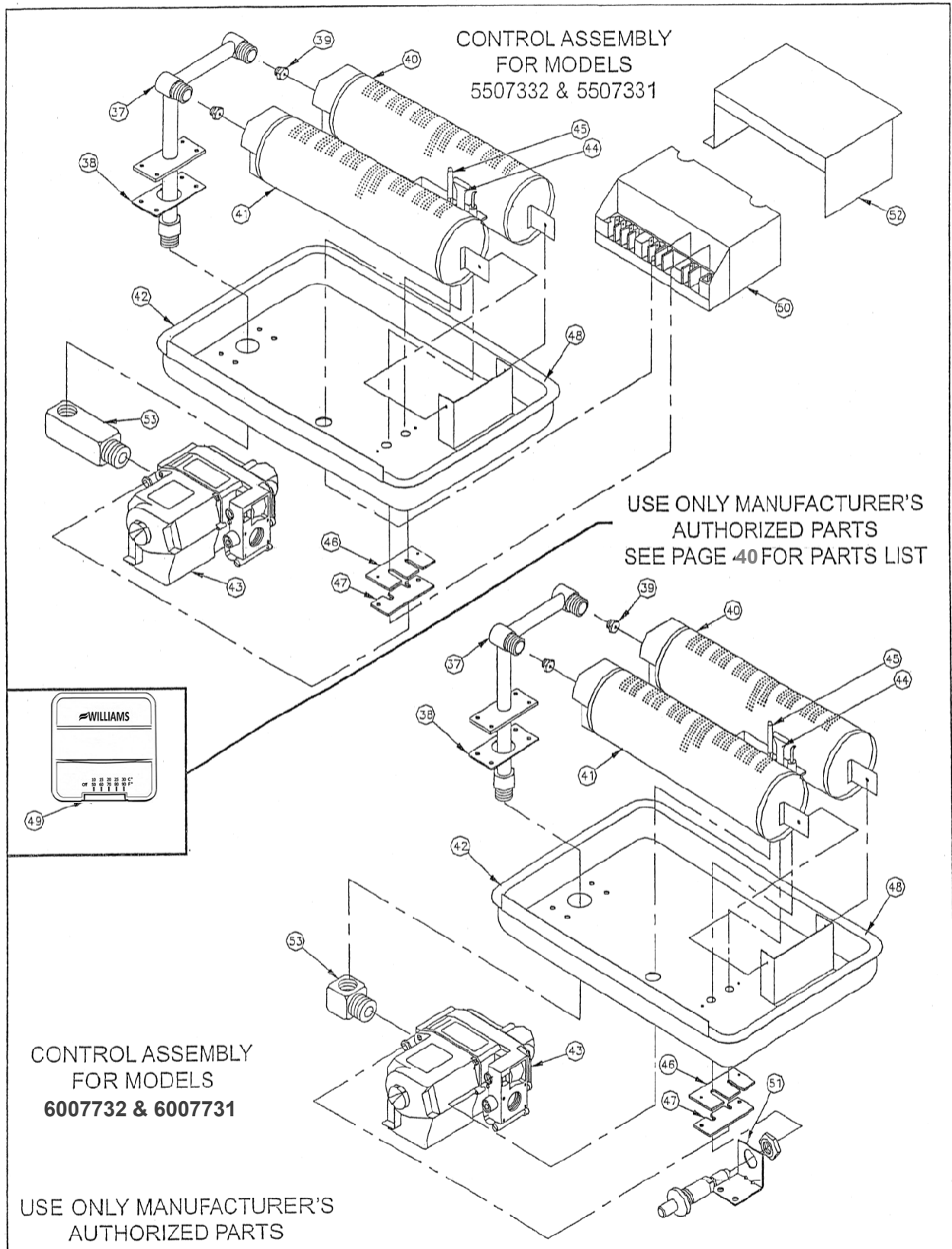


FOR PARTS LIST  
SEE PAGE 41

USE ONLY MANUFACTURER'S  
AUTHORIZED PARTS

# Replacements Parts

## WILLIAMS DIRECT VENT GAS-FIRED WALL FURNACE



# Replacements Parts

## REPLACEMENT PARTS LIST FOR MODELS 5507332 and 5507331

Ref. Number	Description	PART NO. FOR MODEL	
		5507332	5507331
1	Outer Casing with Air Pan	11C42-1	11C42-1
2	Heating Element	11C66	11C66
3	Element Tube	11C37	11C37
4	Inner Liner	7B79	7B79
6	Deflector Baffle Handle	11C63	11C63
7	Fan Shroud	11B86	11B86
9	Top Front Panel	11B102	11B102
10	Center Front Panel	11C59	11C59
11	Bottom Front Panel	11B103	11B103
12	Element Face Cover	11A103	11A103
13	Limit Switch	P296001	P296001
14	Selector Switch	P200400	P200400
15	Fan Switch	P200200	P200200
16	Motor	P062101	P062101
17	Motor Support (2 Req.)	7B46	7B46
18	Transformer	P024200	P024200
19	Internal Wires (Except Ignition Control Wires)	7A194	7A194
20	Vibration Mounts (4 Req.)	P022800	P022800
21	Fan Blade	P200600	P200600
22	Switch Box	11B05	11B05
23	Switch Box Cover	11C68	11C68
25	Peep Hole Cover	12B40	12B40
26	Element Face Gasket	P200900	P200900
27	Air Pan Tunnel Gasket	P151900	P151900
28	Seal Gasket	P103100	P103100
29	Vent Cap	11C09	11C09
30	Flue Extension	} 9802 Kit	11A217
31	Air Inlet Extension		11B144
*	* 4701 Trim Strip Kit		4701
32	* Inner Boot	} 6701 Side Outlet Kit	6701
33	* Outer Boot		
34	* Plaster Ground		
35	* 6702 Side Casing Grille Kit	6702	6702
36	* 6703 Diffusing Grille Kit - Two-Way	6703	6703
	* 6704 Diffusing Grille Kit - Two-Way	6704	6704
36A	Gasket, Burner Pan (2 Req.)	P321020	P321020
**	Owner's Manual	P321004	P321004

\* Not available separately, in kit form only.

\*\* Not Shown.

For part illustration, see page 36.

Note: Screws and bolts are standard hardware items, available locally.

# Replacements Parts

## REPLACEMENT PARTS LIST FOR MODELS 5507332, 6007732, 5507331 and 6007731

Ref. Number	Description	PART NO. FOR MODEL			
		5507332	6007732	5507331	6007731
37	Manifold	P323654	P323654	P323654	P323654
38	Manifold Gasket	P151700	P151700	P151700	P151700
39	Orifice Fitting, Specify Model & Gas	P090541	P090538	P090552	P332621
40	50 mm Burner (With pilot bracket)	P323648	P323648	P323648	P323648
41	50 mm Burner (Without pilot bracket)	P323649	P323649	P323649	P323649
42	Burner Pan	11B134	11B156	11B134	11B156
43	Valve, Nat.	—	P323209	—	—
	Valve, L.P.G.	—	—	—	P322042
	Valve, Nat.	P323210	—	—	—
44	Valve, L.P.G.	—	—	P322044	—
	Pilot, Nat.	P323418	P323418	—	—
45	Pilot, L.P.G.	—	—	P323419	P323419
	Thermocouple	—	P254000	—	P254000
	Flame Sensor	P271100	—	P271100	—
46	Pilot Tube Gasket	P151800	P151800	P151800	P151800
47	Pilot Tube Seal	11A41	11A41	11A41	11A41
48	Gasket - 44 inch	P101600	P101600	P101600	P101600
49	Thermostat	P322016	P322016	P322016	P322016
50	Ignition Control Unit	P321900	—	P321900	—
51	Piezo Gas Lighter	—	P285500	—	P285500
52	Ignition Shield	11B139	—	11B139	—
53	Manifold Adapter	P321887	P321888	P321887	P321888
**	Ignition Control Wires	31B036	—	31B036	—

\* Not available separately, in kit form only.

\*\* Not Shown.

For part illustration, see page 38.

Note: Screws and bolts are standard hardware items, available locally.



# Replacements Parts

## REPLACEMENT PARTS LIST FOR MODELS 6007732 and 6007731

Ref. Number	Description	PART NO. FOR MODEL	
		6007732	6007731
1	Outer Casing with Air Pan	11C42-1	11C42-1
2	Air Pan Tunnel Gasket	P151900	P151900
3	Inner Liner	11B120	11B120
4	Heating Element	11C66	11C66
5	Peep Hole Cover	12B40	12B40
6	Burner Pan Gasket (2 Req.)	P321020	P321020
7	Bottom Front Panel	11B103	11B103
8	Center Front Panel	11C59	11C59
9	Bottom Air Deflector	11B123	11B123
10	Center Air Deflector	11B119	11B119
11	Selector Switch	P200400	P200400
12	Fan Switch	P200200	P200200
13	Switch Box Cover	11C68	11C68
14	Switch Box	11B05	11B05
15	Seal Gasket	P103100	P103100
16	Element Baffle	11B116	11B116
17	Limit Switch	P321942	P321942
18	Top Air Deflector	11B119	11B119
19	Top Front Panel	11B102	11B102
20	Fan Shroud	11B86	11B86
21	Element Face Gasket	P304000	P304000
22	Fan Blade	P200600	P200600
23	Motor	P321601	P321601
24	Motor Support (2 Req.)	7B46	7B46
25	Vibration Mounts (4 Req.)	P022800	P022800
26	Transformer	P024200	P024200
27	Internal Wires	6007732	6007731
28	Element Tube	11C37	11C37
30	Vent Cap	11C09	11C09
31	Air inlet Extension	} 9809 Kit	11B144
32	Flue Extension		
33	* Inner Boot	} 6701 Side Outlet Kit	6701
34	* Outer Boot		
35	* Plaster Ground		
36	* 6702 Side Casing Grille Kit	6702	6702
37	* 6703 Diffusing Grille Kit - Two-Way	6703	6703
37A	* 6704 Diffusing Grille Kit - One-Way	6704	6704
*	** 4701 Trim Strip Kit	4701	4701

\* Not available separately, in kit form only.

\*\* Not Shown.

For part illustration, see page 37.

Note: Screws and bolts are standard hardware items, available locally.

# Installations in the State of Massachusetts

All installations in the State of Massachusetts must use the following requirements when installing, maintaining or operating direct-vent propane or natural gas-fired space heaters.

For direct-vent appliances, mechanical-vent heating appliances or domestic hot water equipment, where the bottom of the vent terminal and the air intake is installed below four feet above grade the following requirements must be satisfied:

1. If there is not one already present, on each floor level where there are bedroom(s), a carbon monoxide detector and alarm shall be placed in the living area outside the bedroom(s). The carbon monoxide detector shall comply with NFPA 720 (2005 Edition).
2. A carbon monoxide detector shall be located in the room that houses the appliance or equipment and shall:
  - a. Be powered by the same electrical circuit as the appliance or equipment such that only one service switch services both the appliance and the carbon monoxide detector.
  - b. Have battery back-up power;
  - c. Meet ANSI/UL 2034 Standards and comply with NFPA 720 (2005 Edition); and
  - d. Have been approved and listed by a Nationally Recognized Testing Laboratory as recognized under 527 CMR.

A carbon monoxide detector shall:

- a. Be located in the room that houses the appliance or equipment;
  - b. Be either hard-wired or battery powered or both; and
  - c. Shall comply with NFPA 720 (2005 Edition).
3. A product-approved vent terminal must be used, and if applicable, a product-approved air intake must be used. Installation shall be in strict compliance with the manufacturer's instructions. A copy of the installation instructions shall remain with the appliance or equipment at the completion of the installation.
4. A metal or plastic identification plate shall be mounted at the exterior of the building, four feet directly above the location of vent terminal. The plate shall be of sufficient size to be easily read from a distance of eight feet away, and read "Gas Vent Directly Below".

## Gas Conversion Kits

<b>Gas Conversion Kits</b>	
<b>Natural Gas to L.P. Gas</b>	
<b>Model</b>	<b>Description</b>
7728	40073/40077 Series
7730	55073 Series
7732	60077 Series

<b>Gas Conversion kits</b>	
<b>L.P. Gas to Natural Gas</b>	
<b>Model</b>	<b>Description</b>
7729	40073/40077 Series
7731	55073 Series
7733	60077 Series

# Forsaire Hardwire Accessory - 9940

## Installation Instructions

This Kit is for use with Models: 3508331; 3508332; 3508731; 3508732; 4007331; 4007332; 4007731; 4007732; 5008731; 5008732; 5507331; 5507332; 5508331; 5508332; 6008531; 6008532; 6007731; 6007732; 6508731; 6508732

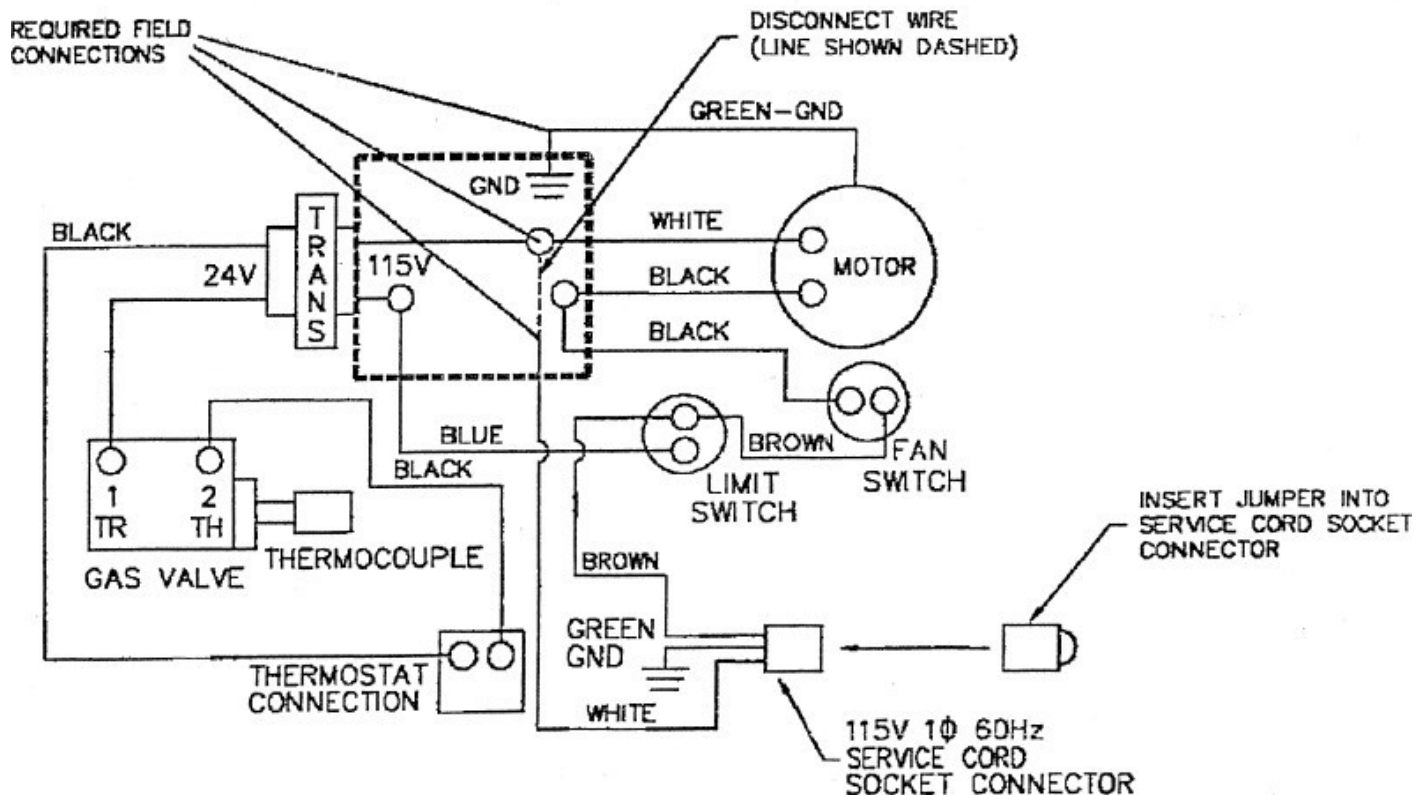
**WARNING:** Danger of bodily injury. Turn off electric power supply at disconnect switch, fuse box or service panel before working on the furnace.

**SUMMARY:** This accessory converts Williams' Forsaire Counterflow furnaces using the electric service cord provided, to a hardwired, permanent electrical connection.

If this furnace is equipped or has been previously installed and operated using the service power cord, disconnect the cord at the receptacle connector located at the base of the furnace and remove the cord completely from the furnace.

Following the wiring diagram below, make all the necessary wiring connections from an outside electrical source. All electrical work must conform to your local codes and ordinances or in their absence, with National Electrical Code, ANSI/NFPA 70 or in Canada, Canadian Electrical Code C22.1. If you are not familiar with wiring codes in general, have a competent electrician do this job. Be sure this accessory is of the type and design required for use with your furnace.

The 40077 model series with a single speed motor is shown in the wiring diagram below. The required field wiring connections are applicable to all models listed above. For internal wiring connections to your model, refer to the wiring diagram attached to the furnace.



# Troubleshooting

## TROUBLESHOOTING CHART FOR Models FOR MODELS: 4007732; 6007732; 4007731; 6007731

\*Also applicable to Models equipped with an electric intermittent pilot system. (Continued on next page)

SYMPTOM	POSSIBLE CAUSE	CORRECTIVE ACTION
1. Pilot will not stay lit after following lighting instructions.	A. Thermocouple producing insufficient millivolts.	Check pilot flame – it must impinge on the thermocouple. The pilot flame may be low or blowing (high) causing pilot to drop out. The pilot orifice or aerating hole may be plugged (check for spiders, webs or other organic material). Be sure the thermocouple is fully inserted in its bracket.
	B. Loose or dirty thermocouple connection at gas valve.	Clean and/or tighten the thermocouple fitting at the connection to the valve.
	C. Thermocouple defective.	Check thermocouple with millivolt meter – it should generate approximately 30 millivolts when not connected to a load. When connected to a load, it should generate approximately 14 millivolts. If below 7 millivolts, replace.
	D. Thermomagnet pilot safety defective	Replace gas valve after above is checked out.
2. Main burner will not come ON - pilot burning and thermostat set for heat.	A. Gas valve not turned ON after lighting the pilot.	Turn gas valve knob to the "ON" position - if no main gas flow, proceed to Step "B".
	B. Electric power to furnace turned OFF.	Check for line voltage at furnace - if okay and no main gas flow, proceed to Step "C".
	C. Low voltage transformer or limit switch defective.	Check for 24 volts at the low voltage terminals of the transformer. If no voltage, turn OFF electric power to furnace. Remove one wire from the limit switch and check for continuity across both terminals. No continuity – replace the limit switch. With a good limit switch back in the circuit and the electric power turned ON - if no voltage, replace transformer. NOTE: Before replacing the transformer or limit switch, check wiring for loose connections or broken wires and repair as needed. If voltage is present at transformer, proceed to Step "D".
	D. Wall thermostat defective.	With thermostat set for heat (contacts closed) check for voltage at the terminals on gas valve. If no voltage is present replace defective thermostat. NOTE: Before replacing thermostat, be sure to check the wiring from the furnace to thermostat for loose connections or broken wires and replace as needed. If voltage is present at the terminals on gas valve and still no gas flow to main burners, proceed to Step "E".
	E. Burner orifice plugged.	Clean or replace the orifice - if okay and still no gas flow to main burners, proceed to Step "F".
	F. Gas valve defective.	Replace defective gas valve.
3. Burner comes "ON" but goes OFF before blower turns ON.	A. Defective wiring.	Turn OFF electric power to the furnace. Remove the top front panel, fan shroud and blower wheel. Refer to Wiring Diagram and check all wiring inside the junction box. Remove center front panel and check all wiring inside switch box containing fan, limit and selector switches. Correct if necessary. If correct, proceed to Step "B". NOTE: Selector switch used only on Models 5507331, 5507332, 6007731 & 6007732.
	B. Defective limit switch.	If the burner goes OFF in less than five minutes from room temperature start, check the limit control switch. If defective, replace. NOTE: Blower should turn "ON" within three minutes after burner is "ON" from a room temperature start. If not, proceed to Step "C".
	C. Defective motor (2-speed).	Jumper across the fan switch, turn electric power ON, the motor should rotate. If a 2-speed motor is used - jumper from "brown" terminal on the fan switch to #2 (red) terminal on the selector switch, motor should rotate on "LOW" speed. Jumper from same "brown" terminal on the fan switch to #3 (black) terminal on the selector switch, motor should rotate on "HIGH" speed. Replace motor if defective.
	D. Defective motor (1-speed).	Jumper across the fan switch, turn electric power ON, motor should rotate. Replace motor if defective.
	E. Detective fan switch.	If, after checking the above possibilities, problem still exists, replace the fan switch.

# Troubleshooting

SYMPTOM	POSSIBLE CAUSE	CORRECTIVE ACTION
4. Burner comes "ON", blower comes "ON", but cycles "ON" and "OFF" while burner remains "ON".	A. Furnace not operating at full rate.	Check for low gas pressure at gas valve - should be 4" W.C. for Natural Gas, 11" W.C. for L.P. Gas. Check burner orifice.
5. Burner comes "ON", blower comes "ON", but burner cycles "OFF" and "ON" with blower "ON".	A. Furnace operating over-rate.	Check for high gas pressure at the gas valve - correct if necessary. See correct pressure above.
	B. Line voltage too low.	Check line voltage to motor, if below 115 volts the motor will run too slow.
	C. Recirculation.	Heated air discharging against an object causing recirculation, such as a hall installation or a large piece of furniture within 4' of discharge.
6. Furnace operates but turns "OFF" before room temperature is attained.	A. Thermostat location.	Check location of the thermostat. It should not be in the path of warm air discharge from the furnace, near a lamp, or above a TV set or stereo.
	B. Defective thermostat.	Check the thermostat calibration or replace.
7. Furnace operates but will not shut "OFF" when room temperature is attained.	A. Thermostat wiring defective.	Check the thermostat wiring from furnace to the thermostat - may be shorted together by a nail or staple.
	B. Thermostat location.	Check thermostat location - if on an outside wall or there is a hole in wall behind the thermostat causing cold air to contact the thermostat, relocate the thermostat.
8. Abnormal operation.	A. Blower noise.	Check the motor mounts - they may be loose. Fan blade could be out of balance. Set screw may be loose on the motor shaft. Blower may be rubbing on the fan shroud. Motor may need oiling. Correct as needed.
	B. Expansion noise ticking.	Check installation - casing may be twisted or not level when installed. Expansion slip joint may be binding; check by removing vent cap assembly from outside wall.
	C. Selector switch defective (2-speed).	During normal furnace operation the motor will be on "LOW" speed when operating on minimum input capacity and on "HIGH" speed when operating at maximum input capacity. If there is no change in motor speed, replace the selector switch.
9. Burner comes "ON" but goes "OFF" after operating for no apparent reason.	A. Vent tube and air inlet tube improperly installed.	Check the vent tube and air inlet tube. Follow the installation instructions. Be sure joints are tight and both tubes are in place. Use only the vent tubes furnished. Do not extend tubes beyond their original length.

# Troubleshooting

## TROUBLESHOOTING CHART FOR MODELS 4007332; 5507332; 4007331; 5507331

NOTE: Before troubleshooting the intermittent pilot system, be sure thermostat is turned to highest setting, gas shut-off valve and gas valve knob are in the ON position, and electric power is turned ON the furnace. Follow all steps in sequence. A volt-ohm meter will be needed to satisfactorily determine if any components are malfunctioning.

SYMPTOM	POSSIBLE CAUSE	CORRECTIVE ACTION
1. No spark – no pilot gas.	A. No main power.	Perform normal system checks of the main power, transformer, thermostat, limit switch, and replace faulty components. With the power ON, turn the thermostat to the lowest setting, wait for 10 seconds and return to HIGH setting. With the power ON and thermostat set at its highest position, set voltmeter to 24V scale and attach the probes to terminals "TR" and "TH" on the ignition control unit. If you read 24V and there still is no spark or pilot gas, the ignition control unit is defective and must be replaced.
	B. Faulty transformer.	
	C. Faulty thermostat.	
	D. Faulty limit switch.	Test wiring. Repair or replace.
	E. Faulty ignition control.	
	F. Faulty wiring.	
2. Spark – but no pilot gas.	A. Faulty ignition.	See 1E.
	B. No gas supplied to pilot valve.	Check for availability of gas at gas control valve. Make sure the manual valve (gas cock) on the gas control are in the full ON position. No pilot gas could be caused by plugged pilot tubing. Also check the pilot adjustment at the gas control valve.
	C. Manual valves in OFF position.	
	D. Faulty pilot valve.	
	E. Faulty wiring.	See 1F.
	F. Restricted pilot line or clogged pilot orifice.	See 2B.
3. Pilot gas – but no spark.	A. Faulty ignition control.	With power ON, turn the thermostat to the lowest setting, wait for 10 seconds and then return it to the high setting. With power ON and thermostat set at its highest position, set voltmeter to 24V scale and attach probes to terminals "TR" and "TH" on the ignition control unit. If you read 24V and there is still no spark or pilot gas, the ignition control is defective and must be replaced. With thermostat turned to its highest setting, set test meter to 24V scale. Touch probes to "C" and "P" terminals on the Gas Control Valve. If you do not get a 24V reading, check wiring. If wiring tests okay, check the ignition control unit.
	B. Broken or shorted electrode assembly.	Remove wire at "COM" terminal at the ignition control unit, being careful not to touch any metal parts; disconnect the electrode wire at the ignition control unit. Connect one end of a jumper wire to terminal "GND". (DO NOT REMOVE EXISTING WIRE.) Attach the other end of the jumper wire to the metal blade of a small screwdriver. Position the end of metal blade approx. 1/8" from the "HIGH VOLTAGE" (IGN) terminal. Reconnect the "COM" terminal. Sparking should occur between the screwdriver blade and the "HIGH VOLTAGE" terminal. If no sparking occurs, the ignition control unit must be replaced. Check the pilot and electrode assembly for proper electrode gap (3/32" to 1/8") or any possible shorting of electrode to surrounding metal surfaces. Make sure the spark igniter and electrode connections to the ignition control unit are tight. The ignition control unit and pilot burner must both be chassis ground. If there is still no spark, the pilot and electrode assembly must be replaced.
4. Pilot lit, but main burner won't come ON.	A. Faulty ignition control unit.	See 3A.
	B. Faulty wiring.	See 1F.

# Troubleshooting

SYMPTOM	POSSIBLE CAUSE	CORRECTIVE ACTION
	C. Low pilot flame.	NOTE: Wait at least 90 seconds after pilot lights before doing the check out procedures for problem number 4. With the thermostat ON, be sure that the pilot and sensor are properly aligned so that the pilot flame impinges the top 5/8 inch of the sensor. Be sure that the sensor is pushed all the way into the pilot bracket. Adjust the pilot flame with pilot adjustment screw, if necessary. Also check the inlet supply pressure and pilot orifice. If the pilot hood or sensor is bent, the defective unit should be replaced. If the main burner still won't come ON, make sure the main burner orifices are clear. If orifices are clear, set voltmeter to 24V scale and touch probes to the terminals of the main gas operator on the gas valve. Touch probes to terminal "M", "C" on Gas Valve. If you read 24V and the burner won't turn ON, replace entire gas valve.
	D. Improper alignment of sensor in pilot flame.	When the main burner comes ON, ensure that the pilot flame is strong, the sensor is properly aligned, and the pilot flame impinges the top 5/8 inch of the sensor. (See procedures for checking proper pilot flame and alignment in problem 4c.) Check the pilot and electrode assembly for proper electrode gap (3/32" to 1/8") or any possible shorting of electrode to surrounding metal surfaces. Make sure the spark igniter and electrode connections to the ignition control are tight. The ignition control unit and pilot burner must both be chassis ground. If there is still no spark, the pilot and electrode assembly must be replaced.
	E. Faulty flame sensor.	BE SURE POWER IS "OFF" BEFORE PERFORMING THIS TEST!! Set test meter to the "ohm" scale or use continuity checker. Touch one end of the probe to tip of flame sensor, the other to the "SENSE" terminal on the ignition control unit. The Ohmmeter should read "0", continuity should be evident. If you don't obtain a reading, remove wiring from the sensor and test both individually. If continuity is not evident, replace the wiring and/or sensor. There should be NO continuity between sensor and "GND" terminal on the ignition control unit. Test wiring and sensor individually, determine which is shorted on ground. Replace or repair. Turn ON power.
5. Pilot cycles OFF and ON by itself.	A. Faulty pilot valve.	See 2B.
	B. Faulty wiring.	See 1F.
6. Main burner shuts down before thermostat is satisfied.	A. Low pilot flame.	See 4c.
	B. Improper alignment of sensor in pilot flame.	See 4d.
	C. Pilot flame being drawn away from sensor.	When main burner comes ON, ensure that the pilot flame is strong, sensor is properly aligned and pilot flame impinges the top 5/8 inch of the sensor. (See procedures for checking for the proper pilot flame and alignment in problem 4d.) If the pilot flame is drawn away from the sensor when the main burner comes "ON" the cause could be that the manual valve is not in the full ON position. NOTE: Low inlet gas pressure to the gas control valve can be caused by several problems and is not within the scope of the procedures outlined in this service guide. Consult your local utility or gas supplier.
	D. Improper heat anticipator setting.	See 6c. Check the setting of the heat anticipator in the wall thermostat. Set it to the setting specified on the gas control valve.
	E. Faulty limit switch.	The system may be cycling on a faulty limit switch. Using a test meter set to the 110 volt scale, check for a voltage reading across the limit switch when the main burner shuts OFF. If you get a 24 volt or 110 volt reading on shutdown, replace defective limit switch.

# Hints and Information

---

## Service Hints

---

If your furnace fails to work correctly, you may avoid the inconvenience and cost of a service call by checking the troubleshooting section on pages 44 thru 47 before you call for service.

**WARNING:** If the information in this manual is not followed exactly, a fire or explosion may result causing property damage, personal injury or loss of life.

**DO NOT** store or use gasoline or other flammable vapors and liquids in the vicinity of this or any other appliance.

### WHAT TO DO IF YOU SMELL GAS

- Open all of the windows.
- Do not try to light any appliance.
- Do not touch any electrical switch.
- Do not use any phone or cell phone in your building.
- Extinguish any open flame.
- Immediately call your gas supplier from a neighbor's phone. If you cannot reach your gas supplier, call the fire department.

Installation and service must be performed by a qualified installer, service agency or the gas supplier.

## How to Order Repair Parts

---

When ordering repair parts, always give the following information:

1. MODEL NUMBER
2. MFG. DATE CODE
3. PART NUMBER
4. PART DESCRIPTION

All parts listed herein may be ordered from your equipment supplier. The Model Number of your Williams wall furnace will be found on the nameplate near gas valve, inside control compartment.

