

NEWPORT FIRE PIT

GFRC CONCRETE

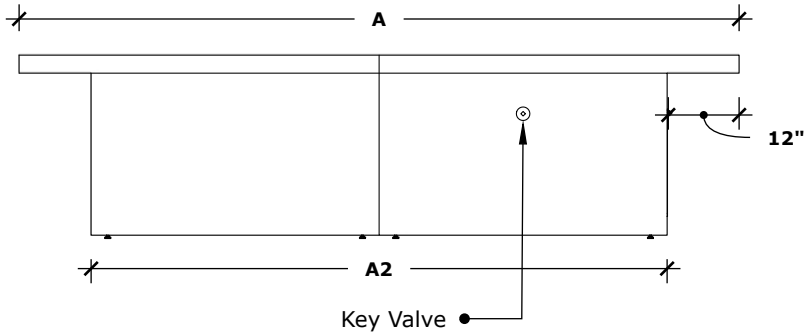

FRONT VIEW

scale: 1/2" = 1'-0" (1:24)

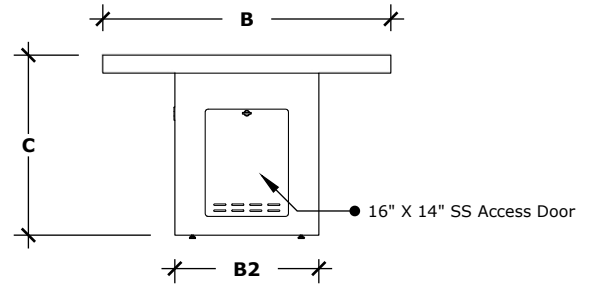

RIGHT VIEW

scale: 1/2" = 1'-0" (1:24)

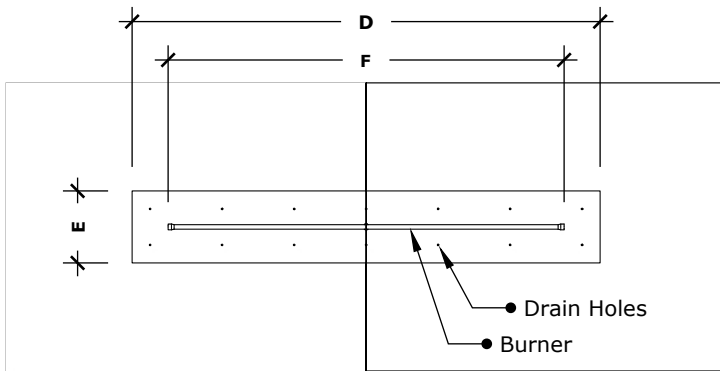

TOP VIEW

scale: 1/2" = 1'-0" (1:24)

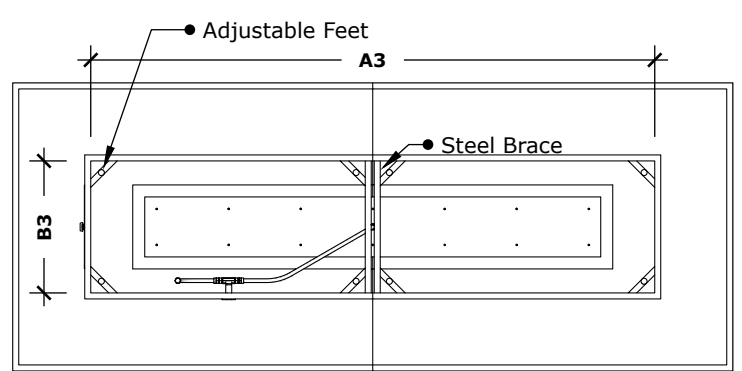

UNDERSIDE VIEW

scale: 1/2" = 1'-0" (1:24)

SKU	A	A2	A3	B	B2	B3	C	D	E	F	BTU
OPT-NPTT72	72"	48"	44"	36"	24"	20"	30"	48"	12"	42"	65,000
OPT-NPTT72EKIT	72"	48"	44"	36"	24"	20"	30"	48"	12"	42"	65,000
OPT-NPTT120	120"	96"	92"	48"	24"	20"	30"	78"	12"	72"	120,000
OPT-NPTT120EKIT	120"	96"	92"	48"	24"	20"	30"	78"	12"	72"	120,000
OPT-NPTT144	144"	120"	116"	48"	24"	20"	30"	102"	12"	96" (M)	240,000
OPT-NPTT144EKIT	144"	120"	116"	48"	24"	20"	30"	102"	12"	96" (M)	240,000

Fire Pit Material: Multiple Standard 2" Depth on all pans

Pan Material: 304 Stainless Steel

Burner Material: 304 Stainless Steel

Match Lit Unit Includes: Pan, Burner, Gas Orifice, Gas Hoses, Key Valve, Key,

110v Ignition Unit Includes: Pan, Burner, Gas Orifice, Gas Hoses, Key Valve, Key, Plug & Play Electronic Valve, Pilot Igniter.



110V ELECTRONIC IGNITION CERTIFICATION

ANSI Z21.97-(2017) / CSA 2.41-(2017)