

ENERVEX MFD MECHANICAL FIREPLACE DAMPER

3916100 08.17

Installation & Operating Manual

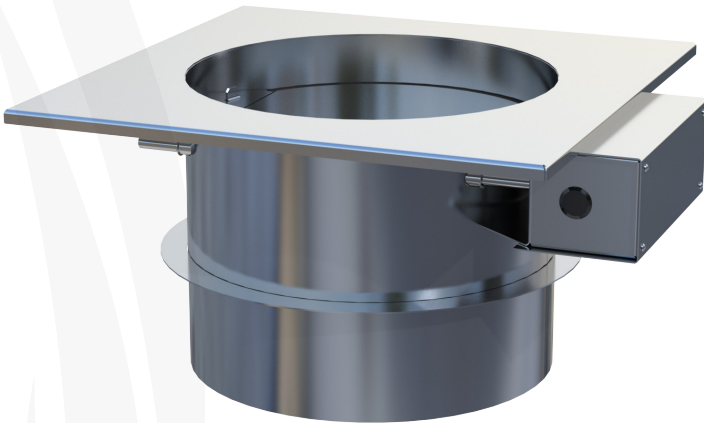

READ AND SAVE THESE INSTRUCTIONS!

IMPORTANT: READ THESE INSTRUCTIONS CAREFULLY PRIOR TO INSTALLATION.

- **EXAMINE ALL COMPONENTS FOR POSSIBLE SHIPPING DAMAGE PRIOR TO INSTALLATION.**

Symbol Legend

The following terms are used throughout this manual to bring attention to the presence of potential hazards, or to important information concerning the product.



DANGER: Indicates an imminent hazardous situation which, if not avoided, will result in death, serious injury or substantial property damage.



WARNING: Indicates an imminent hazardous situation which, if not avoided, may result in personal injury or property damage.

How to use this manual

This installation manual does not contain any system design documentation. System design documentation is available from any authorized ENERVEX representative. Accessories, fans, and variable frequency drives are not covered by this manual. Please refer to these component's individual manuals.

TO REDUCE THE RISK OF FIRE, ELECTRICAL SHOCK OR INJURY TO PERSONS, OBSERVE THE FOLLOWING:

1. Use this unit in the manner intended by the manufacturer. If you have questions, contact the manufacturer at the address or telephone number listed on the front of the manual.
2. Before servicing or cleaning the unit, switch off at service panel and lock service panel to prevent power from being switched on accidentally.
3. Installation work and electrical wiring must be done by a qualified person(s) in accordance with applicable codes and standards.
4. Follow the appliance manufacturer's guidelines and safety standards such as those published by the National Fire Protection Association (NFPA), and the American Society for Heating, Refrigeration and Air Conditioning Engineers (ASHRAE), and the local code authorities.
5. This unit must be grounded.

Content

1. PRODUCT INFORMATION

1.1 Function.....	4
1.2 Shipping	4
1.3 Warranty	4
1.4 Components.....	4

2. SPECIFICATIONS AND DIMENSIONS

2.1 Dimensions and Capacities.....	5
------------------------------------	---

3. MECHANICAL INSTALLATION

3.1 Actuator and Cover.....	6
3.2 Location.....	6

4. ELECTRICAL INSTALLATION

4.1 General.....	7
4.2 Wiring of a Gas Fireplace with a Damper.....	8

5. STARTUP AND CONFIGURATION

5.1 Set Up	10
5.2 Sequence of Operation	10

6. MAINTENANCE

6.1 Cleaning	10
--------------------	----

1. PRODUCT INFORMATION

1.1 FUNCTION

The ENERVEX MFD is a low profile, automated fireplace damper. It is for use in conjunction with an ENERVEX ADC100 control and RS model chimney fan as part of the EcoDamper System. or with an ADC150 control and RS model chimney fan as part of the IntelliDraft System. It prevents excess heat from escaping through the chimney when the fireplace is not in use.

The MFD is designed for chimney top installations and is for use with gas fireplaces only.

The MFD is powered by a 120 or 24 VAC actuator. The actuator is interlocked to the control so it only operates when the fireplace is in use and the fan is running. When there is a call for heat from the fireplace, the ADC100 or ADC150 control begins its operational sequence to open the damper and start the chimney fan. Once the damper opens and there is sufficient draft in the chimney, the control releases the gas valve for fireplace operation.

The actuator has two endswitches to prove damper position (open or closed) and is equipped with the Enerdrive fail safe system to open the damper in the event of an electrical or mechanical failure.

The damper is rated for temperatures up to 575°F (300°C). The damper is sized to provide sufficient clearance between the damper blade and the fan inlet when open.

The MFD is constructed of 18 gauge, type 304 stainless steel.

System installation must conform to the requirements of the authority having jurisdiction. When required by the authority having jurisdiction, the installation must also conform to the NFPA31, NFPA54 or NFPA211.

All electrical wiring must be in accordance with the requirements of the authority having jurisdiction or, in absence of such requirements, with the National Electric Code, NFPA 70.

1.2 SHIPPING

Damper, actuator, cover and hardware are shipped as a unit.

* If other components are shipped, they will appear as separate items on the packing list.

1.3 WARRANTY

2-Year Factory Warranty. Complete warranty conditions are available from ENERVEX, Inc.

1.4 COMPONENTS

Components of the MFD are listed below:

- a. Actuator / Acuator Cover
- b. Stop Flange
- c. Fan Adapter
- d. Collar
- e. Damper Blade

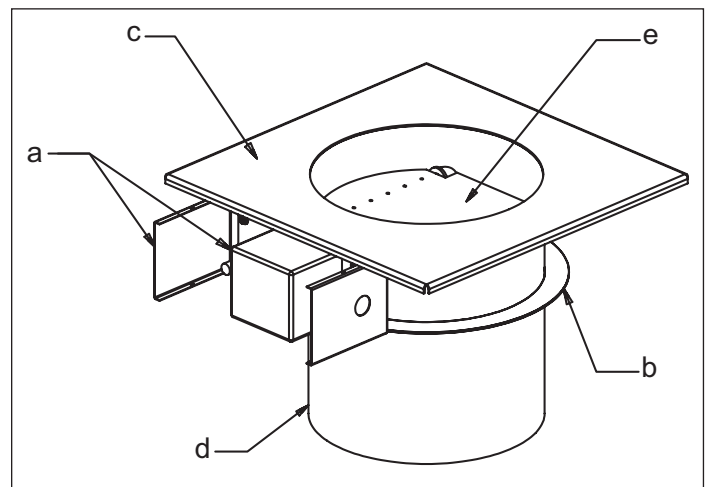

Fig. 1

2. SPECIFICATIONS AND DIMENSIONS

2.1 DIMENSIONS AND CAPACITIES

Fan Model			RS009 and RS012								
Chimney Size			6"	8"	10"	11"	12"	13"	14"	16"	
Dimensions	Ø A	in	5.87	7.87	9.87	10.87	11.87	12.87	13.87	15.87	
		mm	149	200	251	276	302	327	352	403	
	BxB	in	15.60	15.60	15.60	15.60	15.60	15.60	15.60	15.60	19.70
		mm	396	396	396	396	396	396	396	396	500
	C	in	15.75	16.75	17.75	18.25	18.75	19.25	19.75	19.75	22.80
		mm	400	425	451	463	476	489	502	502	579
D	in	2.11	2.27	2.44	2.52	2.61	2.69	2.69	2.77	2.94	
	mm	54	58	62	64	66	68	68	70	75	

Fan Model			RS014 and RS016									
Chimney Size			8"	10"	11"	12"	13"	14"	16"	18"	20"	
Dimensions	Ø A	in	7.87	9.87	10.87	11.87	12.87	13.87	15.87	17.87	19.87	
		mm	200	251	276	302	327	352	403	454	505	
	BxB	in	19.70	19.70	19.70	19.70	19.70	19.70	19.70	19.70	23.30	24.50
		mm	500	500	500	500	500	500	500	500	592	622
	C	in	18.80	19.80	20.30	20.80	21.30	21.80	22.80	22.80	25.60	27.20
		mm	477	503	516	528	541	554	579	579	650	691
D	in	2.27	2.44	2.52	2.61	2.69	2.77	2.77	2.94	3.11	3.27	
	mm	58	62	64	66	68	70	70	75	79	83	

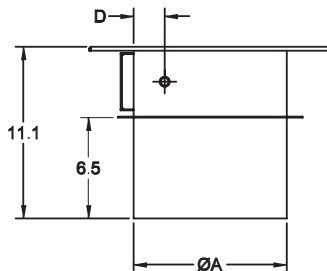
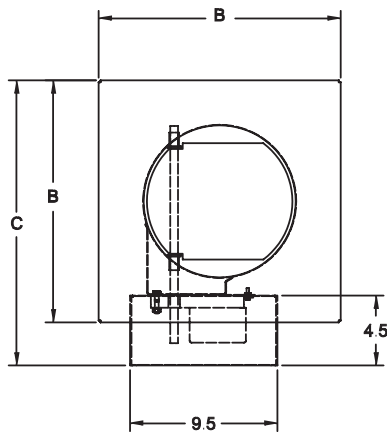

3. MECHANICAL INSTALLATION

3.1 ACTUATOR AND COVER

Before installing the MFD on the chimney, a power cable should be wired to the actuator (See Ch. 4) and the actuator cover should be secured.

Use 4-conductor cable (min. 18 AWG) with a weatherproof jacket such as rubber or silicone. Install a weatherproof cable connector on the side of the actuator cover to prevent water ingress to the actuator.

Use (6) of the included sheet metal screws to secure the actuator cover to the MFD. Once secure, apply a bead of silicone around the seams of the cover.

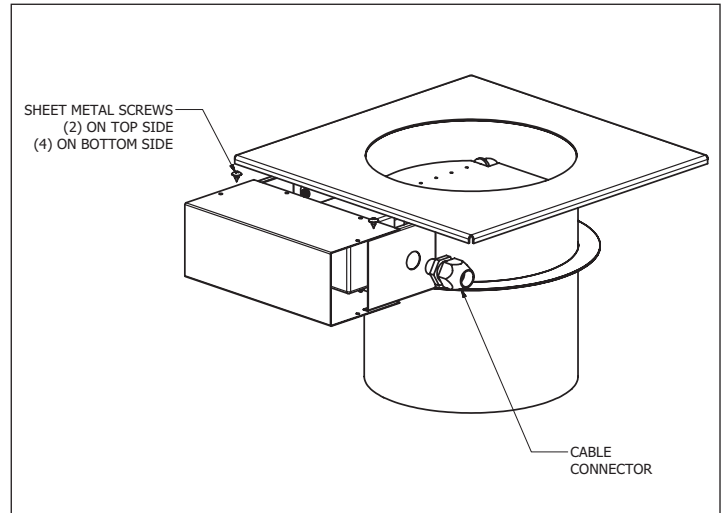

Fig. 2

3.2 LOCATION

Mount the MFD outdoors at the top of a steel chimney. Slide the collar of the MFD into the steel chimney until the damper rests on the stop flange. Sheet metal screws may be installed around the collar into the chimney for additional support.

Once the MFD is secured, place the RS fan on the adapter. Use the mounting holes on the fan base as a drill template to make one mounting hole in each corner of the adapter. Use bolts and locking nuts to secure the fan to the MFD.

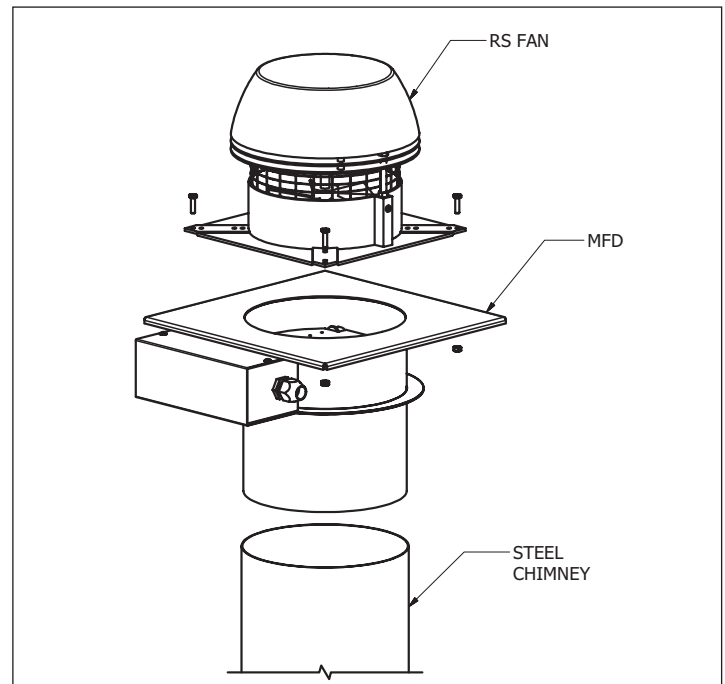

Fig. 3

4. ELECTRICAL INSTALLATION

4.1 GENERAL



DANGER

Turn off electrical power before servicing. Contact with live electric components can cause shock or death.



Verify voltage of actuator before connecting to a power supply. Actuator will run on either 120VAC or 24VAC.

Wire that actuator for 2 wire/ 2 position operation as shown in Fig. 4 (120 VAC) and Fig. 5 (24 VAC) below.

The actuator should be set for clockwise (CW) rotation and should fail to 90° (MFD will open). Verify settings of the actuator before wiring.

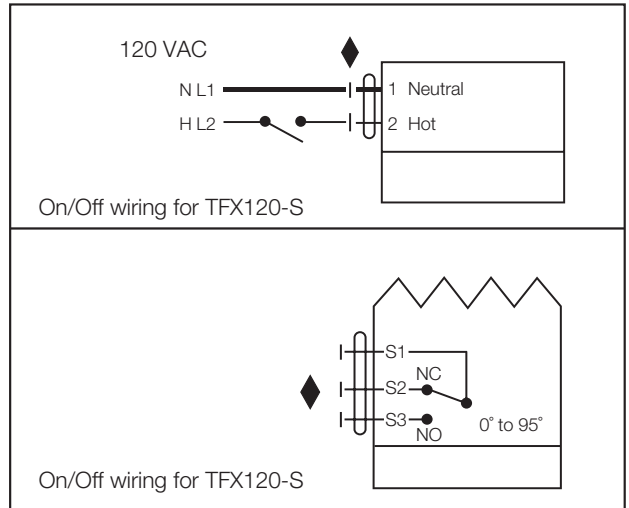

Fig. 4 120 VAC Actuator

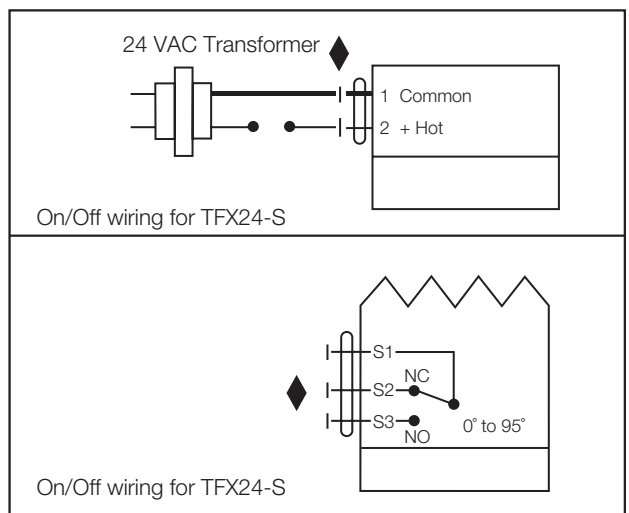

Fig. 5 24 VAC/VDC Actuator

4.2 WIRING OF A GAS FIREPLACE WITH A DAMPER

The MFD must be interlocked to an ENERVELX control. When used with a gas fireplace as part of the EcoDamper System, both a RS Chimney Fan and MFD will interlock with the ADC100 control as shown in Fig.6. When used with an IntelliDraft System, the RS Chimney Fan and MFD will interlock with an ADC150 control as shown in Fig. 7.

Power to the actuator must be supplied externally. Interlock the damper with the control board via terminals 14 and 15 as shown below and on the next page. The Normally Open and Common terminals of the actuator endswitches should connect to the damper prove terminals (16 and 17).

Complete system wiring details are shown in the ADC100 and ADC150 Control Installation Manuals.

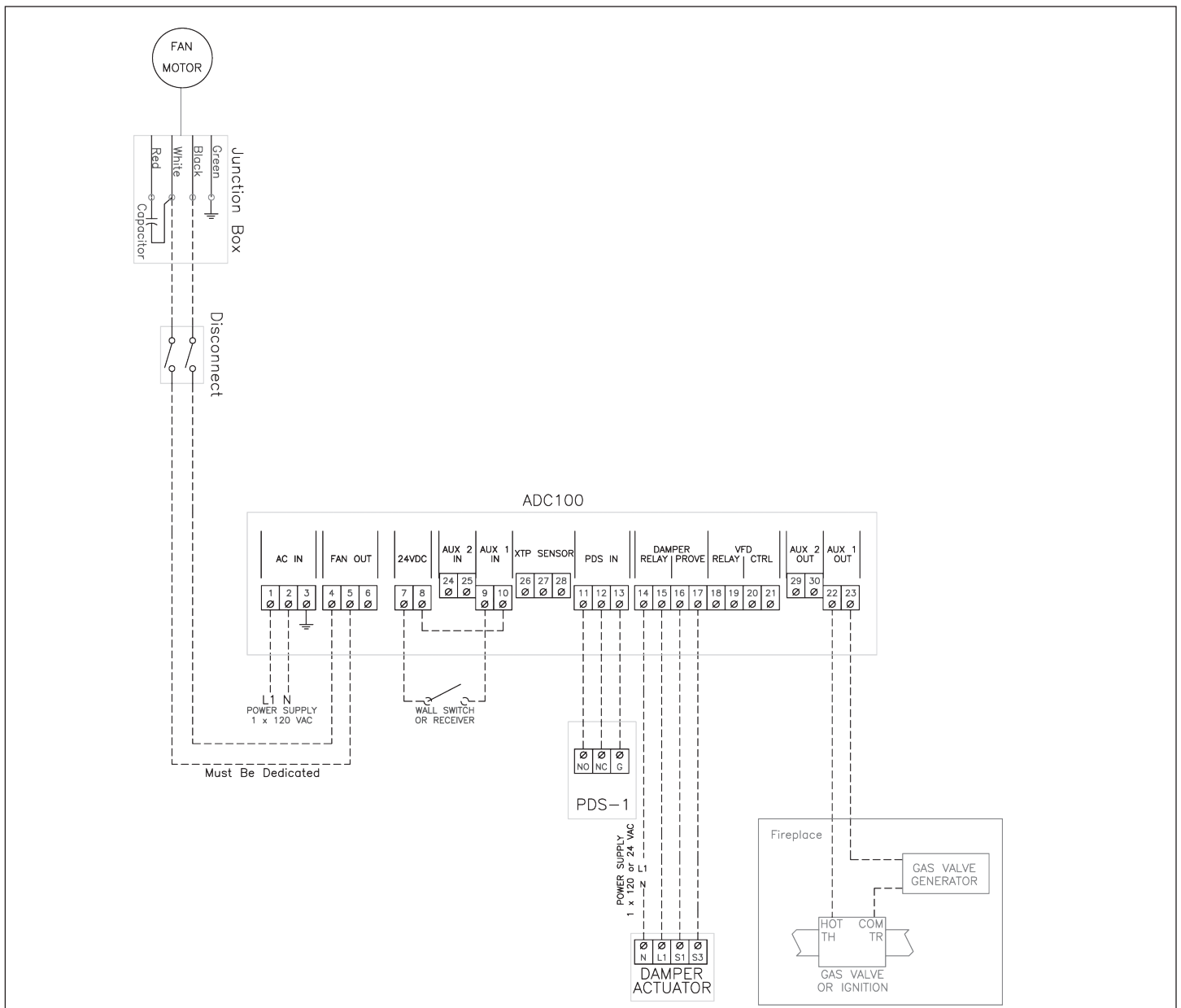

Fig. 6

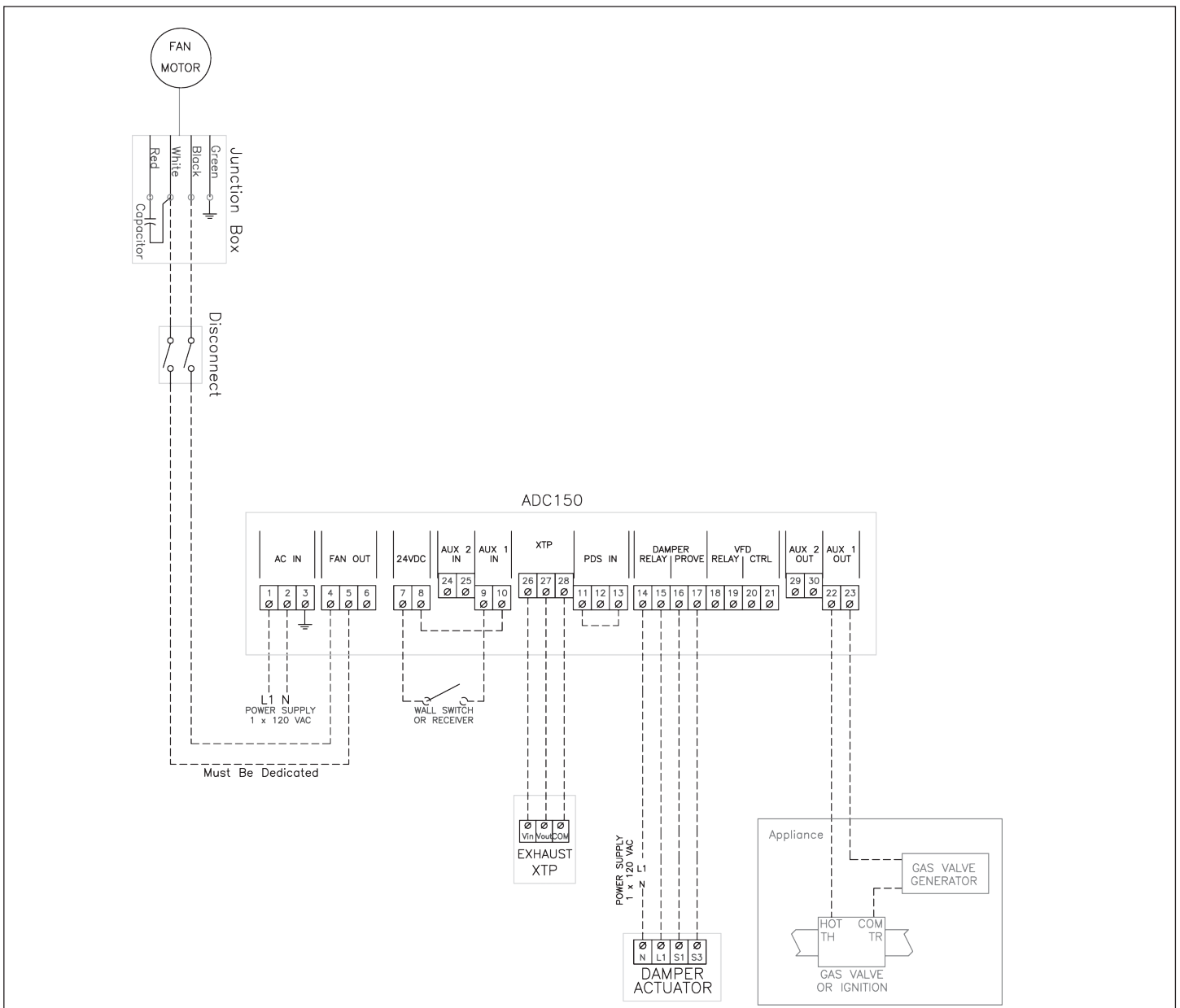

Fig. 7

5. STARTUP AND CONFIGURATION

5.1 SET-UP

Once the MFD has been installed, verify operation and rotation of the damper. The end of the damper rod is notched to indicate position of the damper blade. As the actuator opens the damper, the notch will indicate movement from 0 to 90° in the clockwise (CW) direction.

If the damper does not operate correctly when power is supplied or if it rotates the wrong direction, verify wiring as shown in Ch. 4 of this manual.

5.2 SEQUENCE OF OPERATION

See Ch. 5 of the ADC100 Control Installation Manual for the sequence of operation of the EcoDamper System.

See Ch. 5 of the ADC150 Control Installation Manual for the sequence of operation of the IntelliDraft System.

6. MAINTENANCE AND TROUBLESHOOTING

6.1 CLEANING

Clean the MFD periodically at the same time the fan and/or chimney are cleaned.

Damper should be cleaned with a cloth or rag. Check for and remove any debris that may be blocking the damper opening or chimney.



3916100 08.17