

GAS CONVERSION KIT

KIT P/N	DESCRIPTION
023731	KIT, GAS CONVERSION, KRG/KRD/KRT SERIES, LP
023732	KIT, GAS CONVERSION, KRG/KRD/KRT SERIES, NG

Installation Instructions

Range (KRD/KRG) - Rangetop (KRT) FOR SERVICE PERSONNEL ONLY

IMPORTANT - READ ALL INSTRUCTIONS BEFORE YOU BEGIN

THE INSTRUCTIONS HEREIN MUST ONLY BE PERFORMED BY A QUALIFIED SERVICE TECHNICIAN. THE APPLIANCE MUST BE COMPLETELY COOL AND THE GAS SOURCE MUST BE SHUT OFF OR REMOVED BEFORE ATTEMPTING GAS CONVERSION. FOR KRG MODELS, THE UNIT MUST BE PULLED AWAY FROM THE WALL TO ACCESS THE REAR.

Some parts inside your appliance have sharp edges. Care must be taken when handling the various components to avoid personal injury. Wear gloves when handling. Have a fire extinguisher nearby.

TOOLS REQUIRED:

- Work gloves
- Safety glasses
- Phillips screwdriver
- Flat-blade screwdriver
- Plastic or non-marring pry tool
- Pipe wrench or large slip-joint pliers
- Locking pliers
- Socket wrench with 8mm socket
- Open end or combination wrenches (8, 10, 12, 14mm, 1/2", 7/8")

DANGER

If you smell gas:

1. Shut off gas to the appliance.
2. Extinguish any open flame.
3. Open windows and doors in the room.
4. If odor continues, keep away from the appliance and immediately call your gas supplier or your fire department.

DANGER

1. Do not store or use gasoline or other flammable liquids or vapors in the vicinity of this or any other appliance.
2. An LP cylinder not connected for use shall not be stored in the vicinity of this or any other appliance.

WARNING

IF THE INFORMATION IN THIS MANUAL IS NOT FOLLOWED EXACTLY, A FIRE OR EXPLOSION MAY RESULT CAUSING PROPERTY DAMAGE, PERSONAL INJURY, OR DEATH.

WARNING

Flammable Gas - disconnect all propane or natural gas supplies to this unit before servicing.

WARNING

Electrical Parts & Components – disconnect all power supplies before servicing.

READ THIS MANUAL CAREFULLY AND COMPLETELY BEFORE USING YOUR RANGE TO REDUCE THE RISK OF FIRE, BURN HAZARD, OR OTHER INJURY. KEEP THIS MANUAL FOR FUTURE REFERENCE.

DISASSEMBLY - RANGETOP SECTION

1. Remove the knobs, grates, burner caps and burner rings as shown below. For models with a griddle, remove the cover and grease tray, and lift the griddle plate straight up by the front and back. (KRT485GD shown)

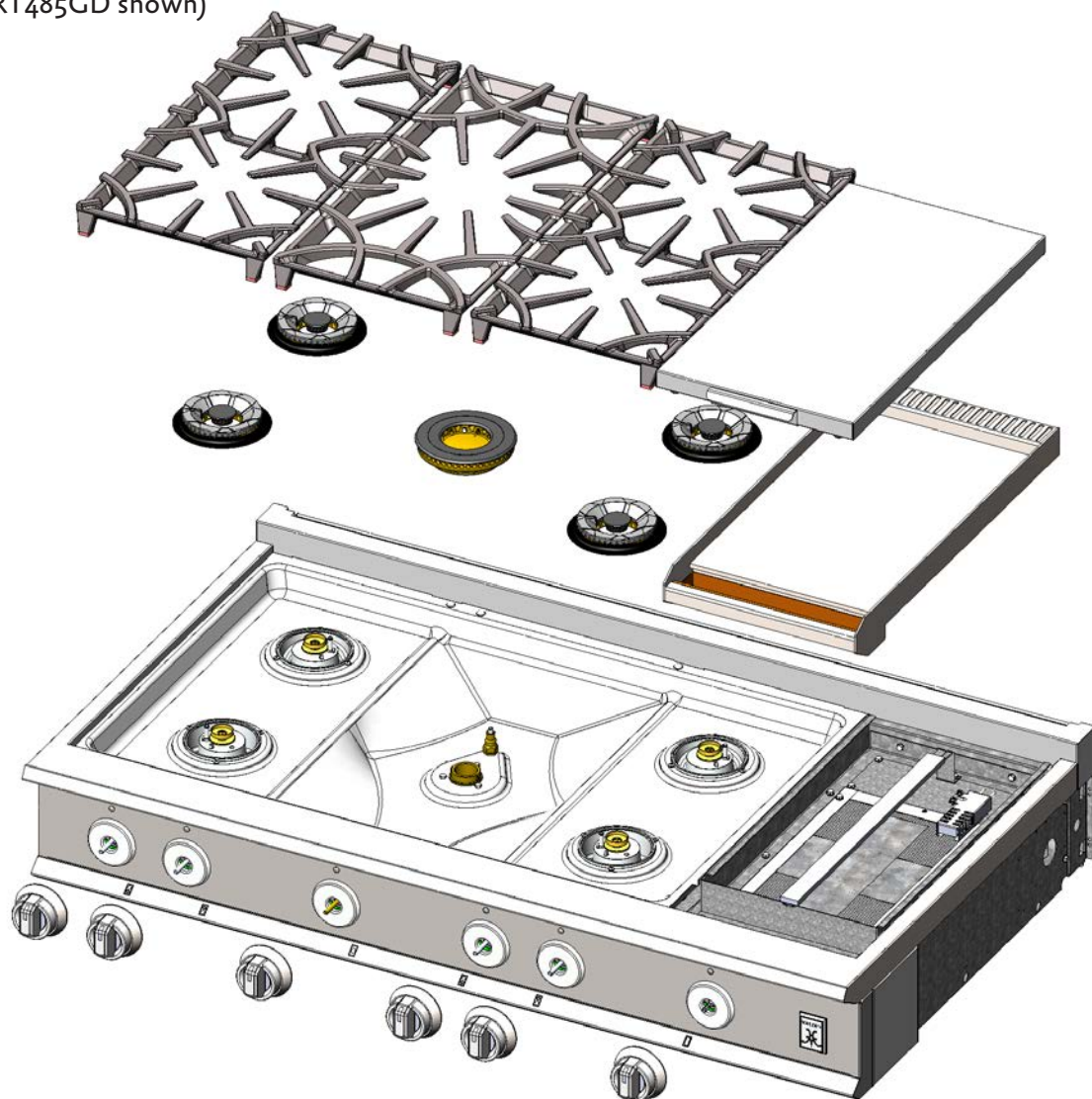

2. Insert a plastic or other non-marring tool to pry into the seam between the control panel and the body in the approximate location shown. Apply light pressure to release the bottom edge of the control panel from the ball retaining studs hidden inside. Repeat for other side. Swing out the bottom edge to remove the panel, and set aside. If your model has a light switch, disconnect the wires (MAKE SURE POWER IS OFF).

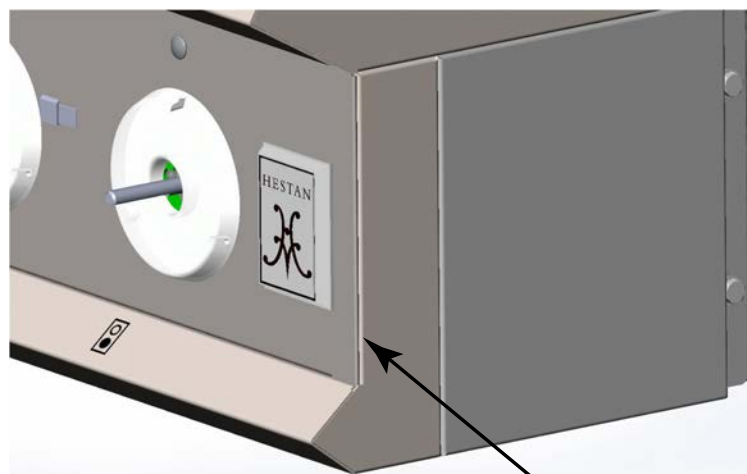

INSERT TOOL HERE

DISASSEMBLY - RANGETOP SECTION (cont.)

EN

3. Remove the screws shown below to detach the bullnose trim assembly.

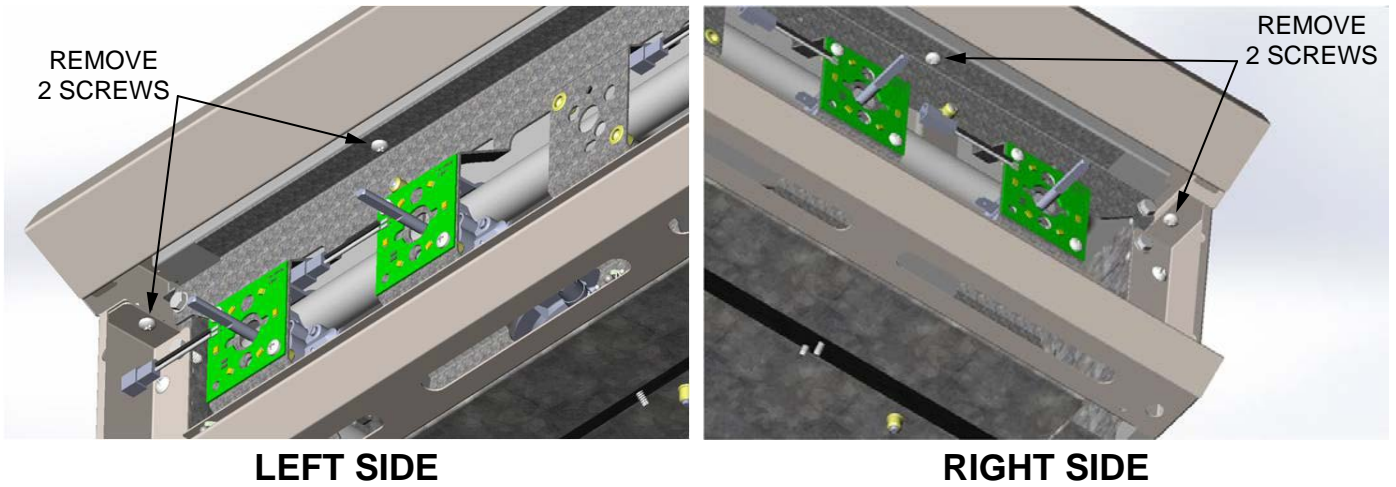

4. Slide the bullnose trim assembly forward as shown and set aside. (KRT365 shown)



5. Remove all screws (red arrows) around each burner base which hold the burner bowl in place. (KRT365 shown)

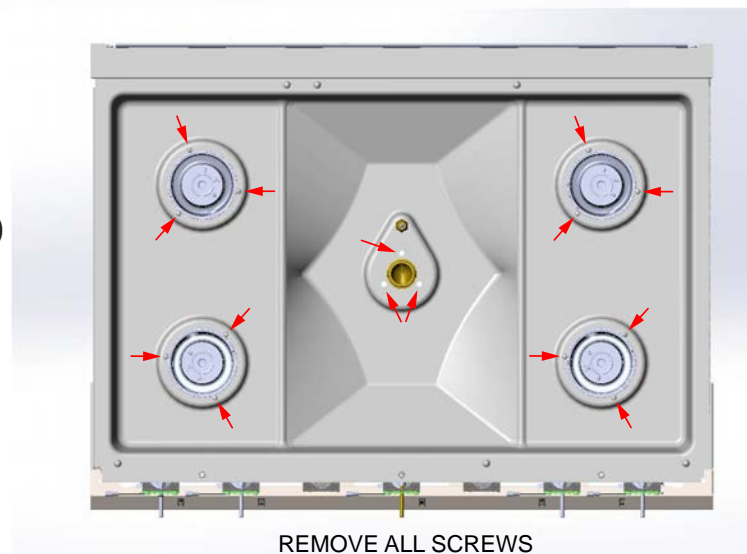

DISASSEMBLY - RANGETOP SECTION (cont.)

6. Remove the burner bowl as shown below. (KRT365 shown)

TILT UP BURNER BOWL ABOUT 30 DEG. TO DETACH FROM REAR ISLAND TRIM / RISER.

NOTE: CENTER BURNER IGNITER WILL REMAIN ATTACHED TO BURNER BOWL WHEN RAISED. DISCONNECT THIS WIRE.

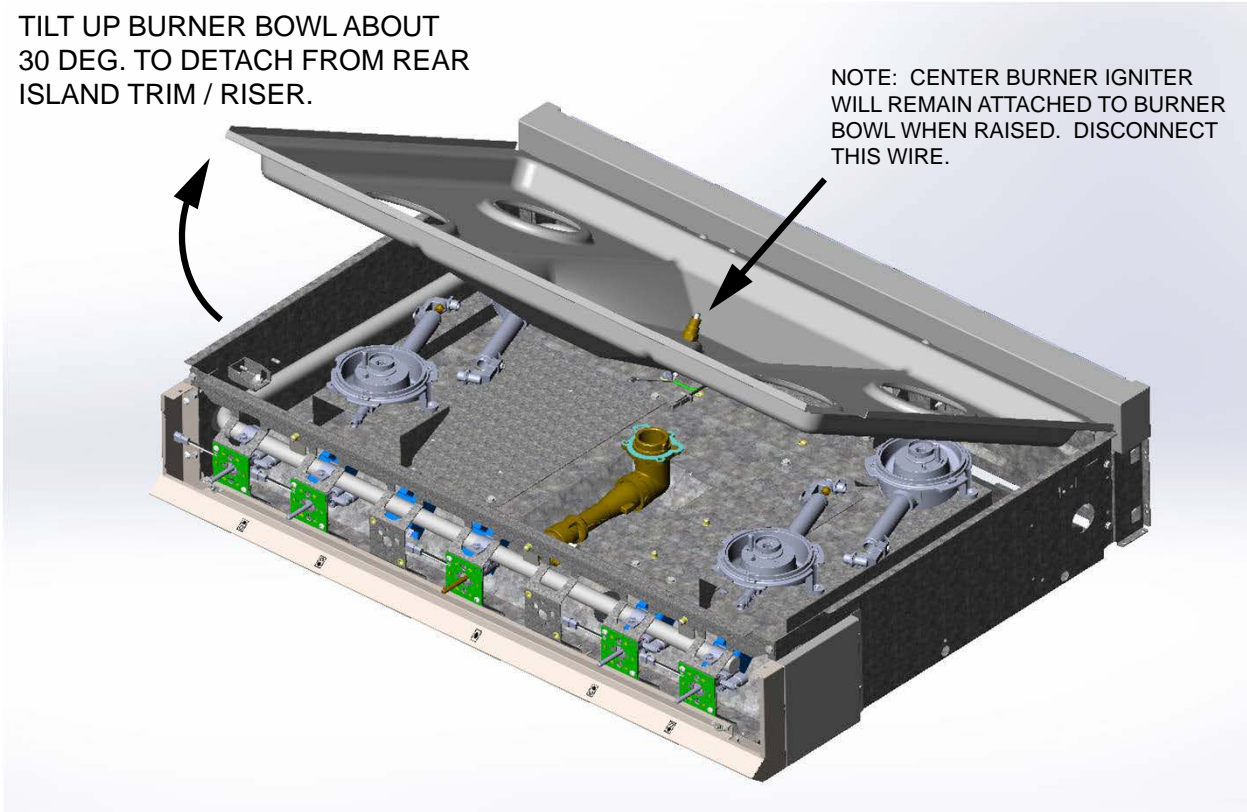

7. Remove each LED board from unit as shown below. You do not have to disconnect each wire connector - they can be left hanging in place. (KRT365 shown)

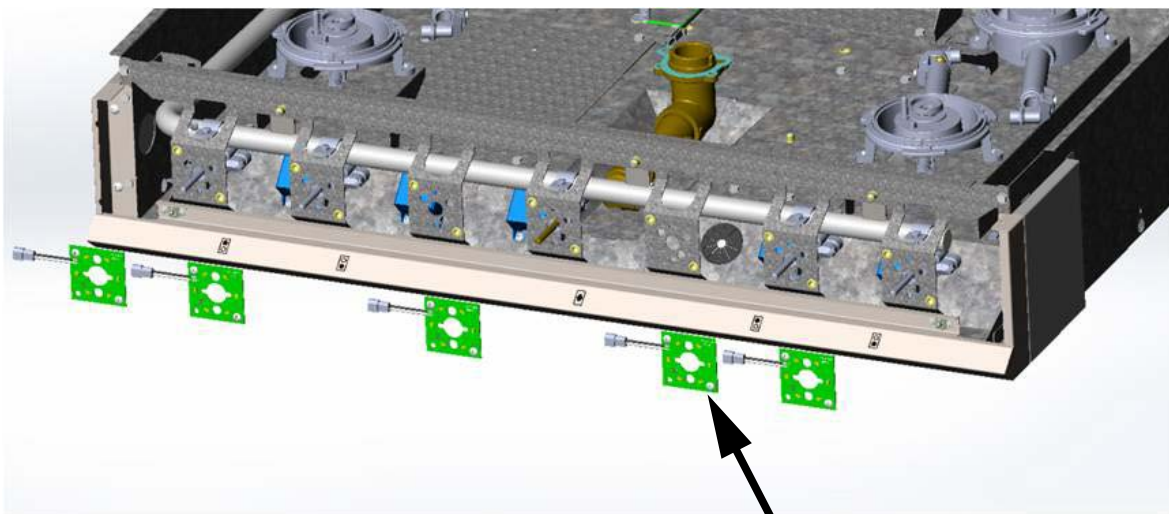

REMOVE LED BOARDS TO EXPOSE VALVE ORIFICE ACCESS HOLES

ORIFICE LOCATIONS - RANGETOP SECTION

Shown below is a typical burner layout. The dual-flow rear burners have 15500 BTU output, while the dual-flow front burners are 23000 BTUs. The center single-flow burner (if equipped) has a 30000 BTU output (or 23000 on LP gas).

EN

TYPICAL BURNER LAYOUT (KRT365 SHOWN)

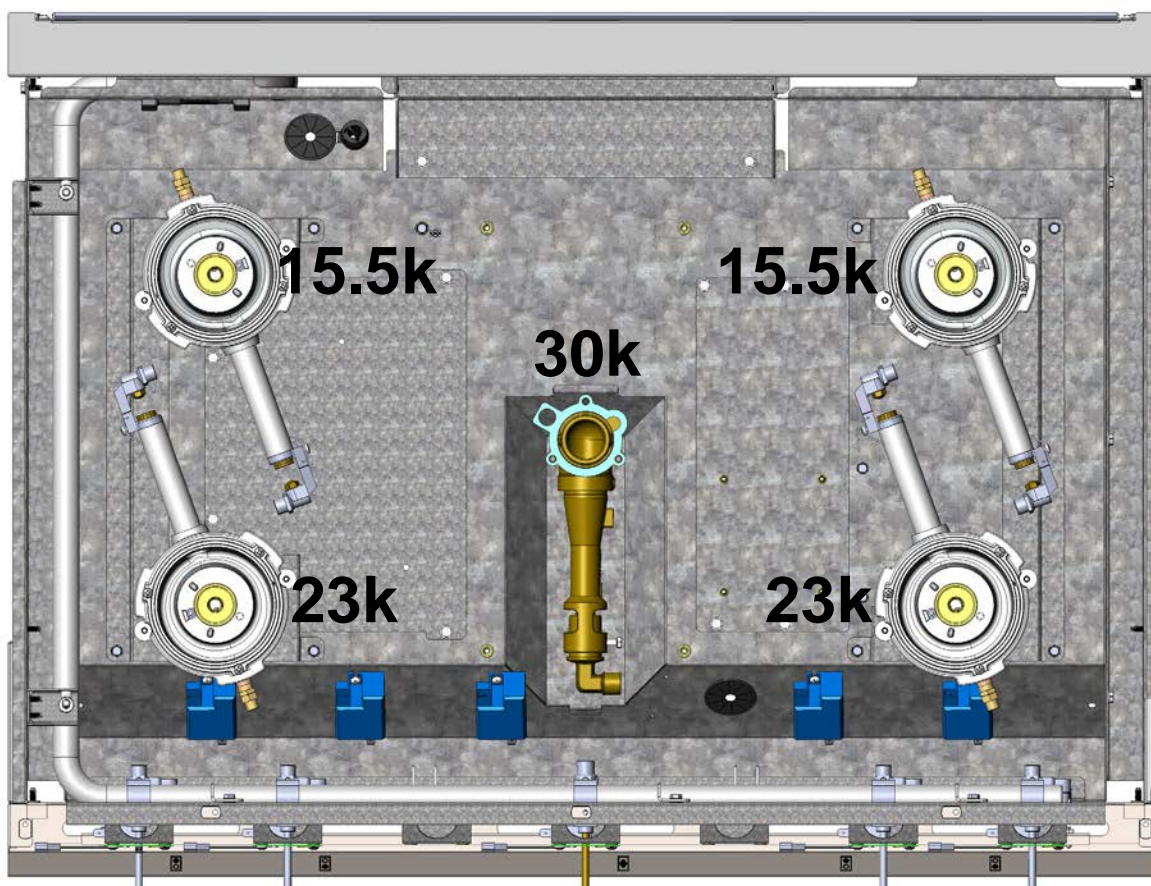

The following pages describe how to replace the orifices in each burner type and each valve type. Do one item at a time so as not to mix up orifices. All orifices must be fully seated and hand-tight to reduce the chances of a gas leak. DO NOT USE any sealant, pipe dope, teflon tape, or anything else on the orifice threads.

ABOUT HOSES: If you need to disconnect any hoses during this process, use caution to avoid unnecessarily bending, twisting, or kinking any hoses. Hoses are stainless steel flex type which can become brittle with age and can crack if handled roughly. Disconnect the fitting carefully where necessary. You will perform a complete gas leakage test at the end of this procedure. If you feel there is a good chance a hose will crack, do not begin this process unless you have replacement hoses. All parts are available by contacting Hestan Customer Care.

ORIFICE CHARTS - RANGETOP SECTION

Use this chart as a guide for replacing the orifices. See following pages for replacement instructions for burners and valves.

EN

BURNER LOCATION	BURNER OUTPUT (BTU/hr)		ALTITUDE	Dual Flow Burner Main Orifice 023690-xxx		Dual Flow Burner Simmer Orifice 023698-xxx		Dual Flow VALVE Low Orifice		Dual Flow VALVE Simmer Orifice	
	NG	LP		NG	LP	NG	LP	NG	LP	NG	LP
Front	23000	23000	Sea Level - 1999 ft (600m)	046	055	073	078	065	073	080	087
Rear	15500	15500		052	058	073	078	065	073	080	087
Front	23000	23000	H1 2000 - 5999 ft (600 - 1800m)	047	055	073	078	065	073	080	087
Rear	15500	15500		053	060	073	078	065	073	080	087
Front	23000	23000	H2 6000 - 10000 ft (1800 - 3050m)	049	056	074	079	065	073	080	087
Rear	15500	15500		054	062	074	079	065	073	080	087

BURNER LOCATION	BURNER OUTPUT (BTU/hr)		ALTITUDE	Single Flow Burner Main Orifice		Single Flow VALVE Orifice	
	NG	LP		NG	LP	NG	LP
Center	30000	23000	Sea Level - 1999 ft (600m)	042	054	062	073
	30000	23000	H1 2000 - 5999 ft (600 - 1800m)	043	055	062	073
	30000	23000	H2 6000 - 10000 ft (1800 - 3050m)	045	056	062	073

CHANGING BURNER ORIFICES - RANGETOP SECTION

PART NO.	DESCRIPTION	Z (IN)	Z (MM)	STAMP	COLOR CODE
023698-073	ORIFICE, SIMMER, DUAL FLOW BURNER, INDOOR, #73	0.024	0.61	V	BLACK
023698-074	ORIFICE, SIMMER, DUAL FLOW BURNER, INDOOR, #74	0.023	0.57	P	PURPLE
023698-075	ORIFICE, SIMMER, DUAL FLOW BURNER, INDOOR, #75	0.016	0.41	T	RED
023698-079	ORIFICE, SIMMER, DUAL FLOW BURNER, INDOOR, #79	0.015	0.37	G	GREEN

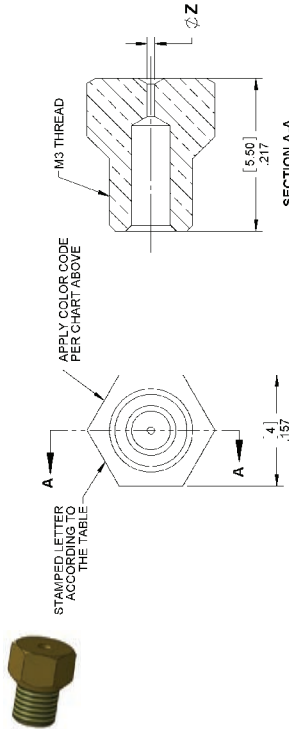

PART NO.	DESCRIPTION	Z (IN)	Z (MM)	COLOR CODE
023690-046	ORIFICE, MAIN, DUAL FLOW BURNER, INDOOR, #46	0.081	2.05	YELLOW, BLACK
023690-047	ORIFICE, MAIN, DUAL FLOW BURNER, INDOOR, #47	0.079	2.00	YELLOW
023690-049	ORIFICE, MAIN, DUAL FLOW BURNER, INDOOR, #49	0.073	1.85	BLACK
023690-052	ORIFICE, MAIN, DUAL FLOW BURNER, INDOOR, #52	0.064	1.60	WHITE, BLACK
023690-053	ORIFICE, MAIN, DUAL FLOW BURNER, INDOOR, #53	0.060	1.52	RED
023690-054	ORIFICE, MAIN, DUAL FLOW BURNER, INDOOR, #54	0.055	1.40	WHITE
023690-055	ORIFICE, MAIN, DUAL FLOW BURNER, INDOOR, #55	0.052	1.32	YELLOW, RED
023690-056	ORIFICE, MAIN, DUAL FLOW BURNER, INDOOR, #56	0.047	1.22	PURPLE
023690-058	ORIFICE, MAIN, DUAL FLOW BURNER, INDOOR, #58	0.042	1.07	WHITE, RED
023690-060	ORIFICE, MAIN, DUAL FLOW BURNER, INDOOR, #60	0.040	1.02	ORANGE
023690-062	ORIFICE, MAIN, DUAL FLOW BURNER, INDOOR, #62	0.038	0.97	GREEN

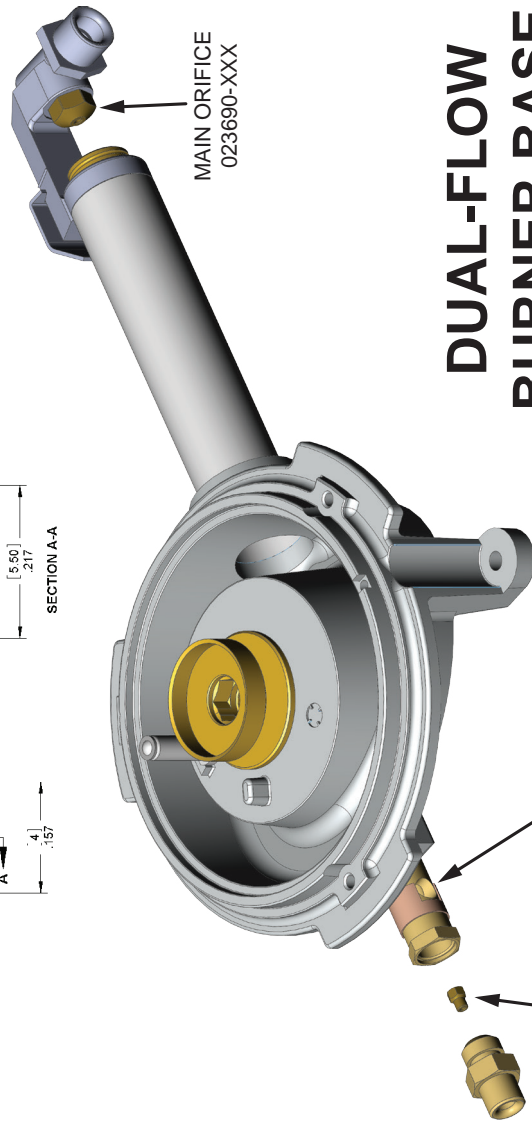
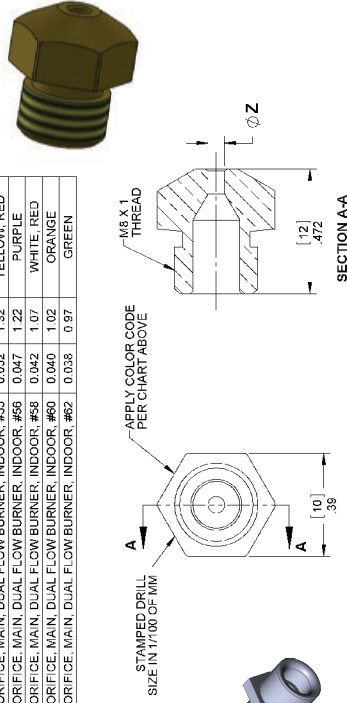

DUAL-FLOW BURNER BASE ASSEMBLY

NOTE: ALIGN VENTURI / SHUTTER WITH 2nd GROOVE. DIMENSION SHOWN FOR REFERENCE ONLY.

- The main BURNER orifice can be replaced without disconnecting the hose. The simmer orifice hose must be disconnected to access the orifice inside. See the chart on page 6 to select the appropriate orifice for your gas type / altitude. The part numbers and identification (color / stamp) for the orifice are given in the tables above.

The detail view shows the appropriate venturi / air-shutter dimension. The dimension is shown for reference only in case the lock screw was loosened, or the flame characteristics are not correct and need adjustment. If adjustment is needed, loosen the lock screw and adjust the air shutter in or out in very tiny increments, lock down the screw, replace all the components and check the flame again.

CHANGING BURNER ORIFICES - RANGETOP SECTION *(cont.)*

PART NO.	DESCRIPTION	Z (IN)	Z (MM)	STAMP
002039	ORIFICE, MAIN, SINGLE FLOW BURNER, #42, NG	0.0935	2.375	42
005681	ORIFICE, MAIN, SINGLE FLOW BURNER, #43, NG	0.0890	2.261	43
016703	ORIFICE, MAIN, SINGLE FLOW BURNER, #45, NG	0.0820	2.083	45
004925	ORIFICE, MAIN, SINGLE FLOW BURNER, #54, LP	0.0550	1.397	54
010343	ORIFICE, MAIN, SINGLE FLOW BURNER, #55, LP	0.0520	1.321	55
011917	ORIFICE, MAIN, SINGLE FLOW BURNER, #56, LP	0.0465	1.181	56

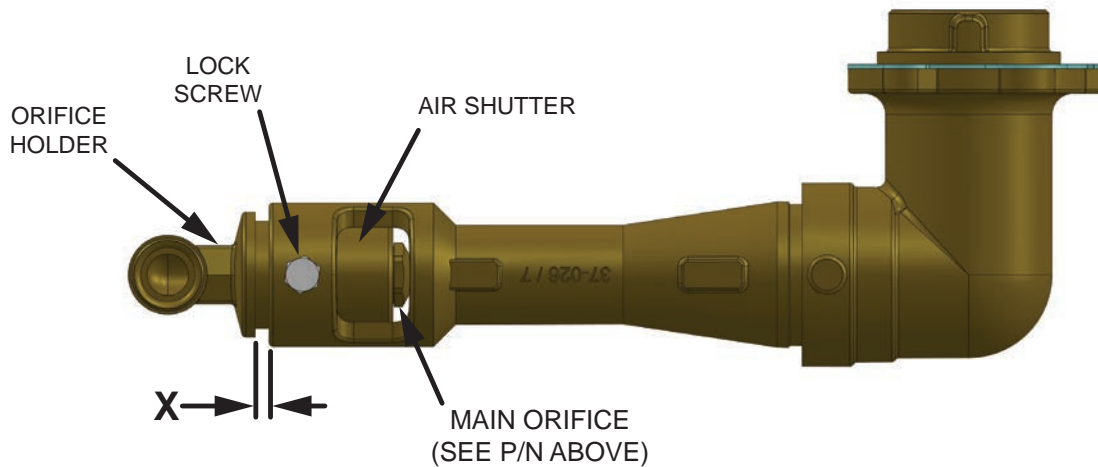
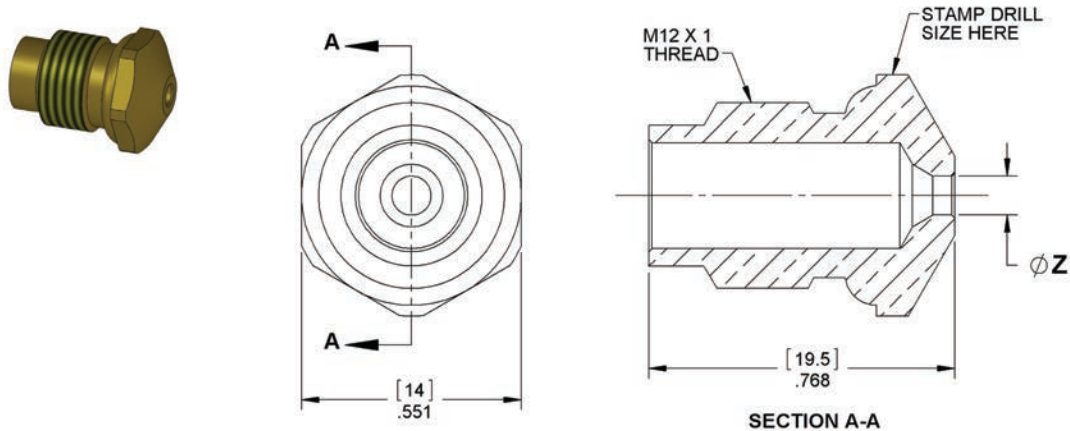

DIM 'X'	GAS
1/8" [3.2mm]	NG
11/64" [4.4mm]	LP

SINGLE-FLOW BURNER BASE ASSEMBLY

- The main BURNER orifice can be replaced without disconnecting the hose, however care must be taken when handling to avoid bending or kinking the hose. Loosen the lock screw to extract the orifice holder from the main body. See the chart on page 6 to select the appropriate orifice size for your gas type / altitude. The part number and identification for the orifice is given in the table above.

When reinstalling the orifice holder in the body, be sure to set the correct air shutter distance (Dimension X), then tighten the lock screw. If later on, the flame characteristics require adjustment, loosen the lock screw and adjust the air shutter in or out in very tiny increments, lock down the screw, replace all the components and check the flame again.

ACCESSING VALVE ORIFICES

10. Remove the valve orifices via the access holes in the bracket as shown below.

**SINGLE-FLOW
VALVE**

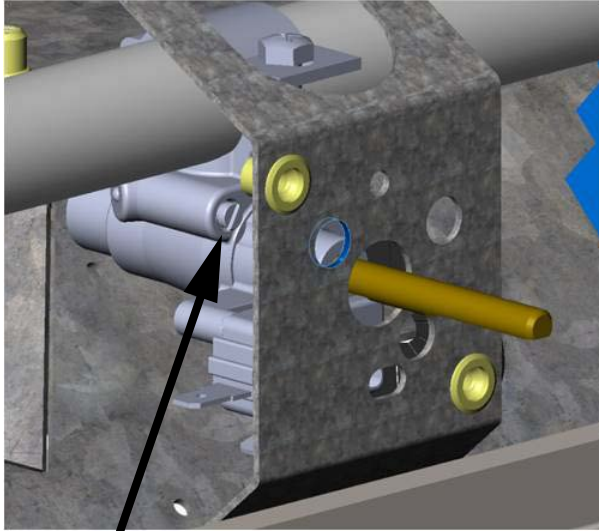

VALVE LOW
ORIFICE

**DUAL-FLOW
VALVE**

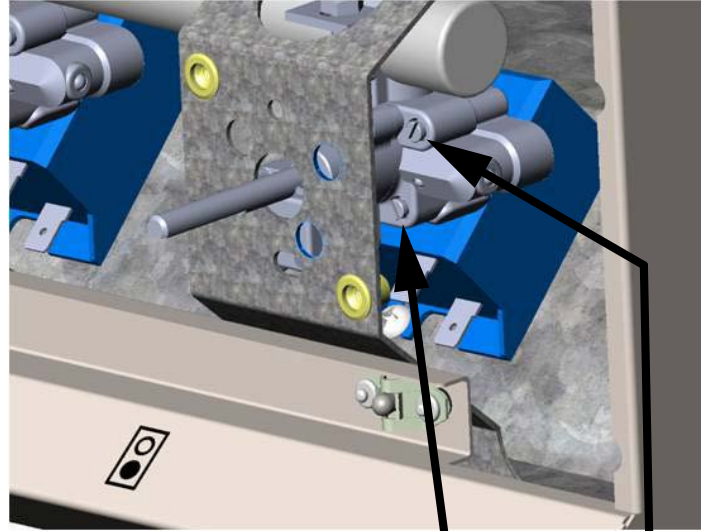

VALVE LOW
ORIFICE

VALVE
SIMMER
ORIFICE

CHANGING VALVE ORIFICES

11. Replace the VALVE orifices as shown below. See the chart on page 6 to select the appropriate orifice size for your gas type / altitude. The part number and identification (color code) for the orifice is given in the table below.

EN

DESCRIPTION	Z (IN)	Z (MM)	COLOR CODE
ORIFICE, VALVE, INDOOR, #62	0.038	0.97	ORANGE
ORIFICE, VALVE, INDOOR, #65	0.035	0.88	BLACK
ORIFICE, VALVE, INDOOR, #73	0.024	0.61	RED
ORIFICE, VALVE, INDOOR, #80	0.0135	0.34	YELLOW
ORIFICE, VALVE, INDOOR, #87	0.010	0.25	WHITE

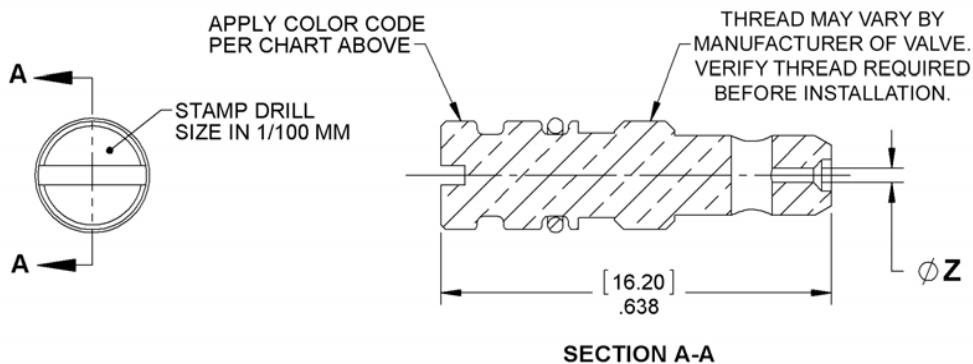

NOTE: REMOVE AND REPLACE ONE ORIFICE AT A TIME. MAKE SURE ORIFICE IS FULLY TIGHTENED ON INSTALLATION.

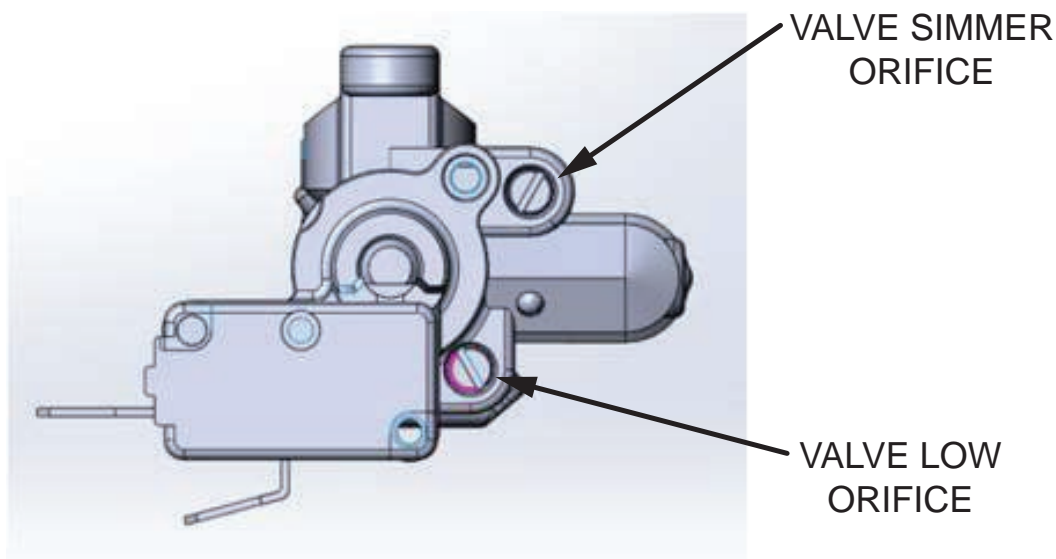

DUAL-FLOW VALVE

CHANGING VALVE ORIFICES *(cont.)*

12. Replace the VALVE orifice as shown below. See the chart on page 6 to select the appropriate orifice size for your gas type / altitude. The part number and identification (color code) for the orifice is given in the table below.

EN

DESCRIPTION	Z (IN)	Z (MM)	COLOR CODE
ORIFICE, VALVE, INDOOR, #62	0.038	0.97	ORANGE
ORIFICE, VALVE, INDOOR, #65	0.035	0.88	BLACK
ORIFICE, VALVE, INDOOR, #73	0.024	0.61	RED
ORIFICE, VALVE, INDOOR, #80	0.0135	0.34	YELLOW
ORIFICE, VALVE, INDOOR, #87	0.010	0.25	WHITE

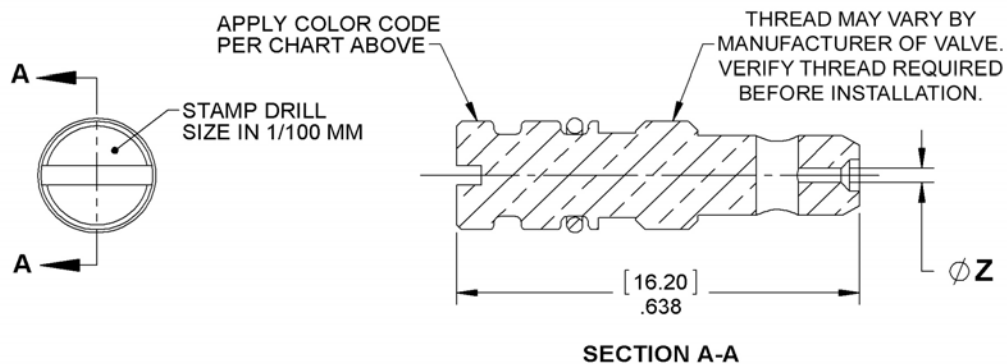

NOTE: REMOVE AND REPLACE ONE ORIFICE AT A TIME. MAKE SURE ORIFICE IS FULLY TIGHTENED ON INSTALLATION.

VALVE LOW ORIFICE

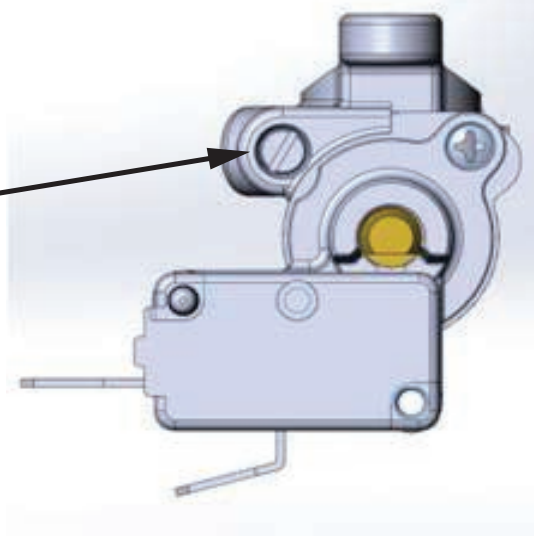

SINGLE-FLOW VALVE

CHANGING ORIFICES - OVEN SECTION (GAS OVEN ONLY)

13. Remove the kick plate below the oven door(s). Fully open the door(s) and remove the screws on the top face of the kick plate. Close the door(s) and pull off the kick plate in a similar way as you did for the control panel, by using a flat tool to apply light pressure to release the left and right sides of the plate from the ball retaining studs hidden inside. Set aside.

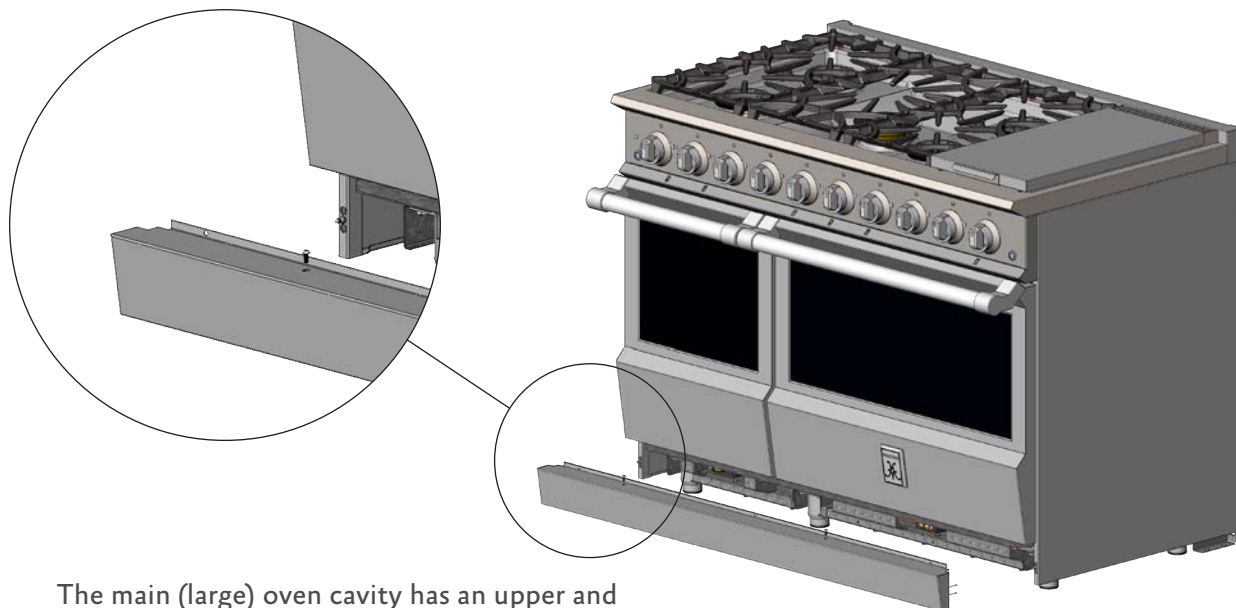

The main (large) oven cavity has an upper and lower burner. For 48" ranges, the companion (small) oven has only 1 lower burner.

14. MAIN OVEN - LOWER BURNER
The lower burner(s) are accessible from the kick plate area. Disconnect the hose at the brass elbow, then remove the 2 screws holding the bracket (shown here in red). Pull the bracket back away. Use caution to avoid unnecessarily bending, twisting, or kinking the hose.

NOTE: It is possible to leave the hose connected, but you must use caution to avoid kinking or damaging the hose.

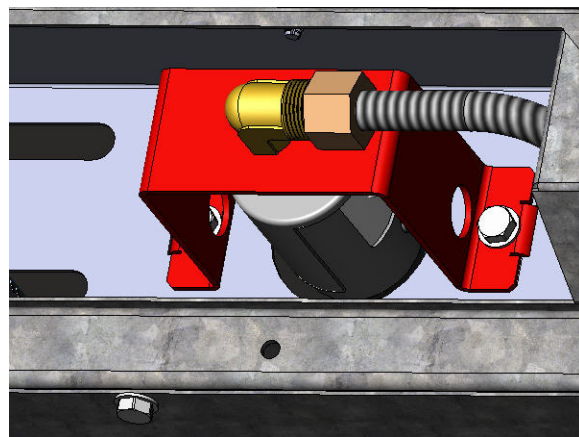

15. You will need to remove the orifice from the brass elbow fitting. However, it is possible to leave the elbow attached to the bracket. Use a pair of locking pliers to keep the elbow from rotating while using a 1/2" wrench to remove the orifice. Notice there is a locknut just below the orifice which must remain tight against the bracket. Make a note as to how far the orifice is threaded onto the elbow fitting. It is touching, or almost touching the locknut.

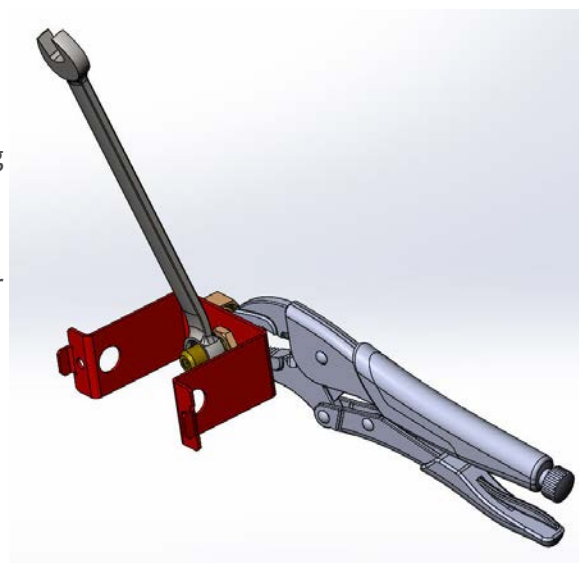

CHANGING ORIFICES - OVEN SECTION (GAS OVEN ONLY) (cont.)

EN

16. Install the new orifice slowly to avoid cross-threading and damaging the threads. Consult the table on page 21 for identification of orifice sizes. The orifice will become noticeably harder to turn as you proceed. Use the same technique as shown in step 15 on the previous page to prevent the elbow from rotating. Check to make sure the locknut is tight against the bracket, and the orifice must be screwed on until touching or almost touching the locknut. Re-install the bracket back into the appliance, and re-attach the hose (if removed).

For the 48" Range, repeat this process for the small oven burner. Do not re-install the kick plate yet.

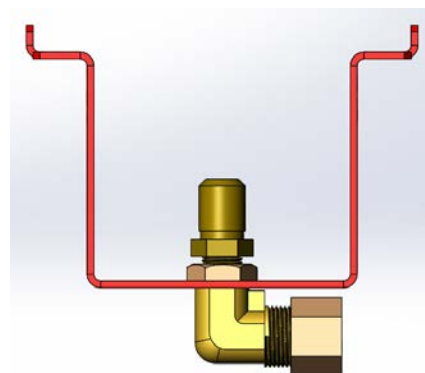

17. COMPANION (SMALL) OVEN ONLY
The air shutter opening must be recalibrated when changing orifices. Loosen the lock screw located on the side of the burner (red arrow). Adjust the opening according to the dimensions below, and re-tighten the lock screw.

Re-install the brackets for all ovens and re-install the hoses. Do not re-install the kick plate yet.

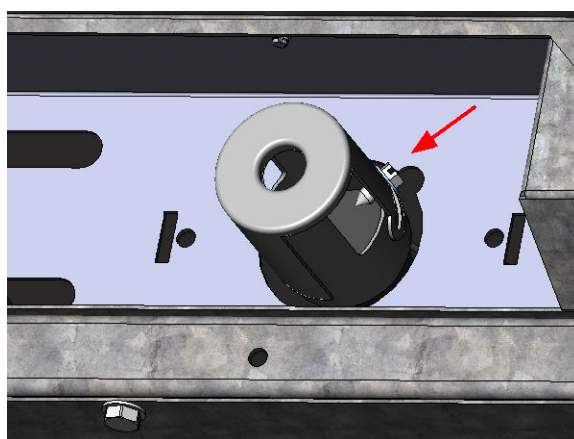

STRAIGHT BURNER - SMALL OVEN

NG = 5/16" [7.9 mm]
LP = 1/2" [12.7 mm]

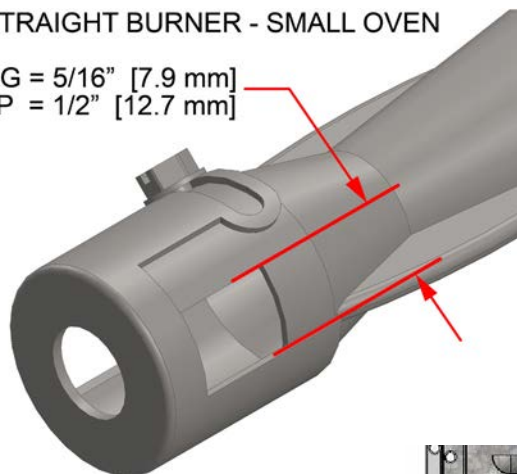

18. MAIN OVEN - UPPER BURNER
The orifice for the upper burner of the main oven cavity is located at the rear of the appliance. Remove the 4 screws (shown here in red) and remove the rear cover (shown in yellow). Set aside.

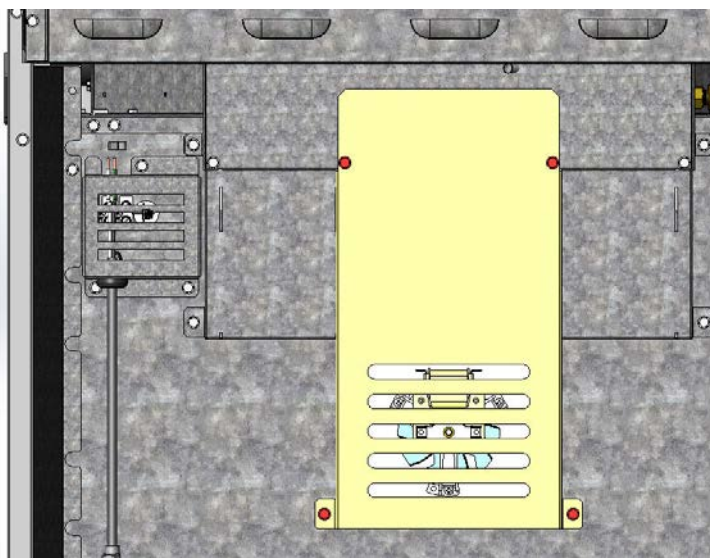

CHANGING ORIFICES - OVEN SECTION (GAS OVEN ONLY) (cont.)

19. MAIN OVEN - UPPER BURNER

It is possible to remove the orifice without disconnecting the hose. Remove the locknut (shown here in violet) with a $7/8$ " wrench. Then remove the orifice with a $1/2$ " wrench. If necessary, use another wrench or locking pliers to prevent the brass elbow from rotating.

Consult the table on page 21 for identification of orifice sizes. When installing the new orifice, it must be completely screwed in as shown in the diagram below, so only the head of the orifice is seen relative to the locknut. The distance between the bracket and the brass elbow must not be changed. Do not re-install the cover yet.

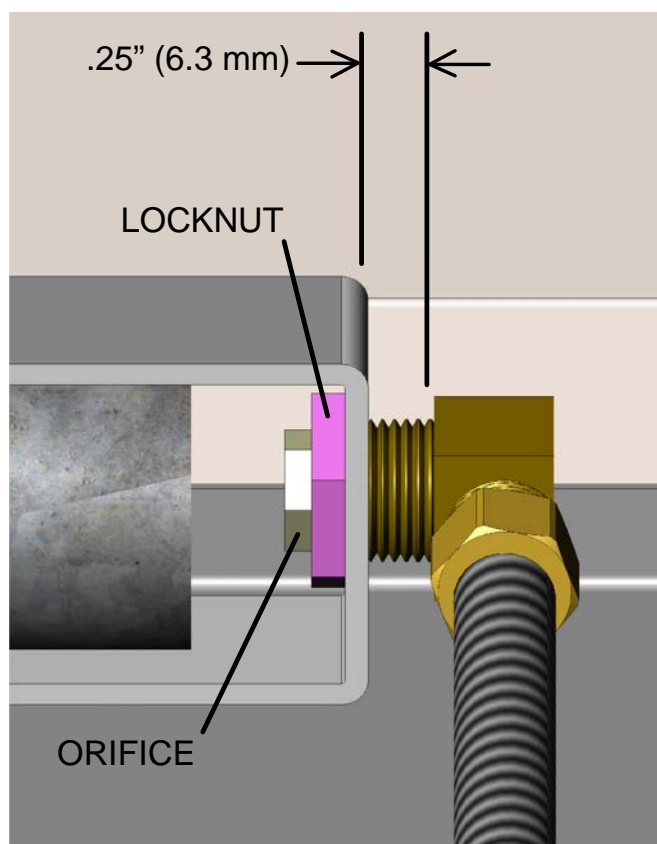
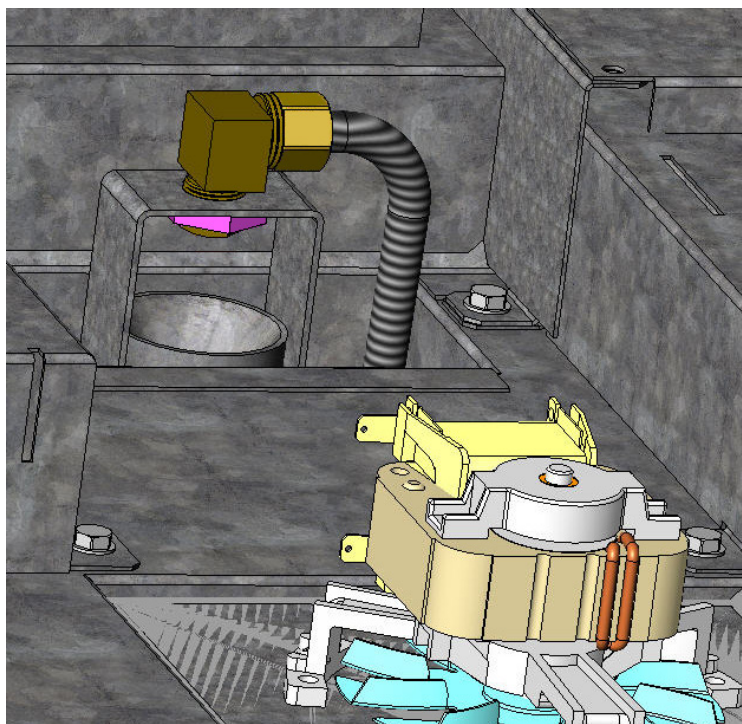

CHANGING ORIFICES - GRIDDLE MODELS ONLY

20. GRIDDLE BURNER

The orifice for the griddle burner is located under the cover below (shown in blue). The hot surface igniter (shown in orange) is attached to this cover. The wires to the igniter pass through the cover. Remove 4 screws (shown in red) and swing the cover carefully out of the way to expose the orifice underneath. Use caution as the igniter is very fragile. The retainer for the temperature sensing bulb is housed in a raised channel (shown in green), which should also not be disturbed.

EN

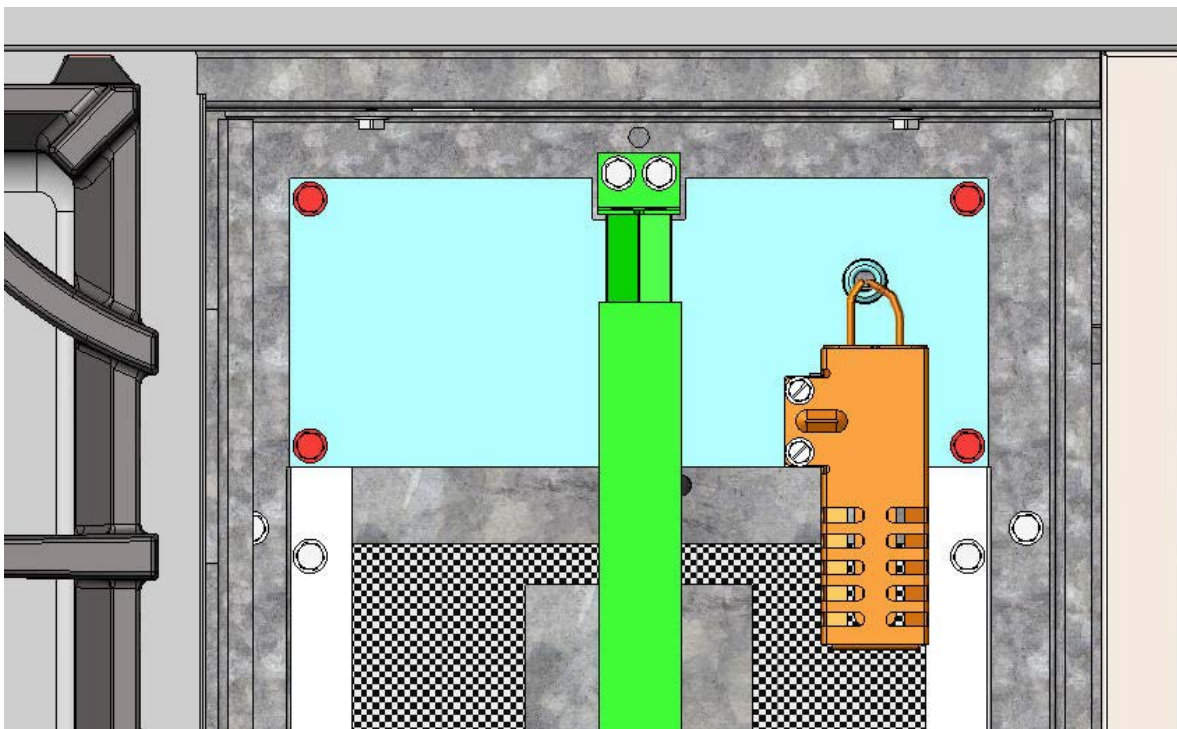

21. The orifice is located as shown here. It is possible to remove the orifice without disconnecting the hose. Remove the locknut (shown here in violet) with a 7/8" wrench. Then remove the orifice with a 1/2" wrench. If necessary, use another wrench or locking pliers to prevent the brass elbow from rotating.

Consult the table on page 21 for identification of orifice sizes. When installing the new orifice, it must be completely screwed in as shown in the diagram on page 14, so only the head of the orifice is seen relative to the locknut. The distance between the bracket and the brass elbow must not be changed. Do not re-install the cover yet.

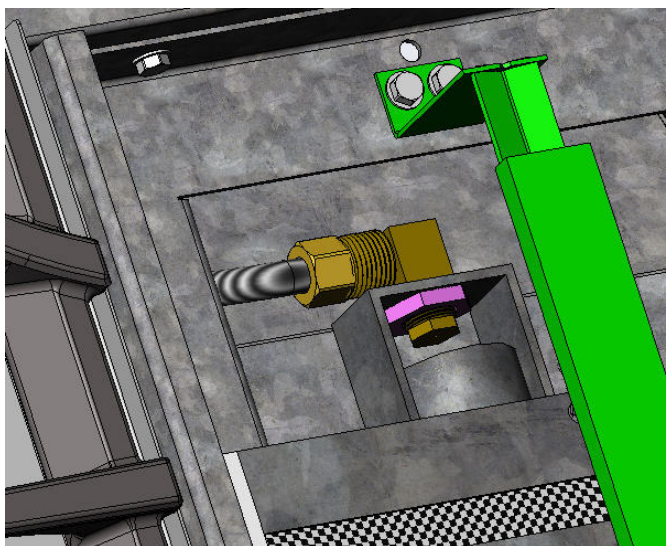

CONVERTING THE REGULATOR

With access to the rear of the appliance, you can convert the gas type of the regulator by following the instructions below (conversion from NG to LP gas is shown). This can be done without removing the regulator.

EN

REMOVE THIS CAP. USE CAUTION, THERE IS A SMALL SPRING INSIDE.

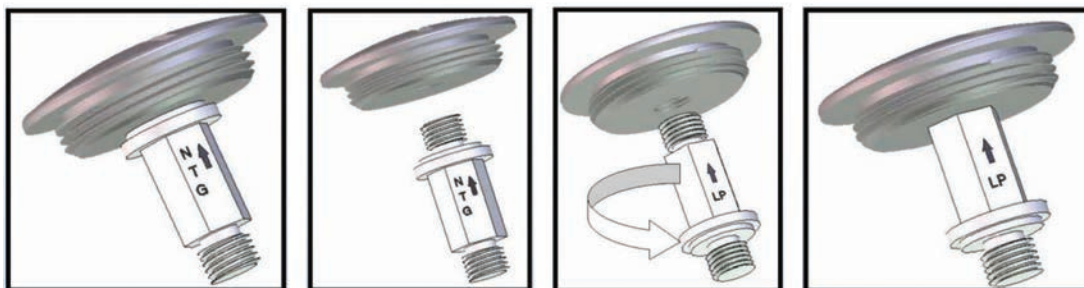
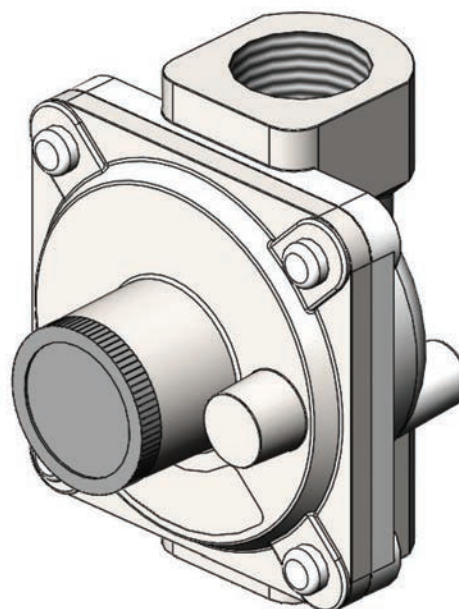

THERE IS A SMALL PLASTIC SPRING GUIDE (USUALLY COLORED BLACK) UNDER THE CAP. UNSCREW THIS PART AND FLIP OVER AND RE-INSTALL IN THE CAP. THEN RE-INSTALL THE CAP INTO THE REGULATOR.

LEAK TESTING & ADJUSTMENT

GAS SUPPLY

The local gas authority or supplier should be consulted at the installation planning stage in order to establish the availability of an adequate supply of gas (NG or LP). If it is a new installation, have the gas authorities or supplier check the meter size and piping to assure that the unit is supplied with the necessary amount of gas supply and pressure to operate the unit(s).

Gas connections should ONLY be made by a qualified plumber, or your professional appliance service technician.

All fixed (non-mobile) appliances must be fitted with an accessible upstream gas shutoff valve as a means of isolating the appliance for emergency shut off and for servicing. This valve was described in the appliance Installation Manual.

LEAK TESTING & ADJUSTMENT *(cont.)*

Make certain new piping and connections have been made in a clean manner and have been purged so that piping compound, chips, etc. will not clog regulators, valves, orifices, or burners.

⚠️ WARNING

IF THE INFORMATION BELOW IS NOT FOLLOWED EXACTLY, A FIRE OR EXPLOSION MAY RESULT CAUSING PROPERTY DAMAGE, PERSONAL INJURY, OR DEATH.

LEAK TESTING TOP BURNERS

At this point, all conversion components should be installed and any hoses removed previously have been returned and tightened. Before replacing the various sheetmetal parts, a complete leak check must be performed on all gas-carrying components.

Begin by temporarily supporting the single-flow center burner (if equipped) with a small block of wood as shown below.

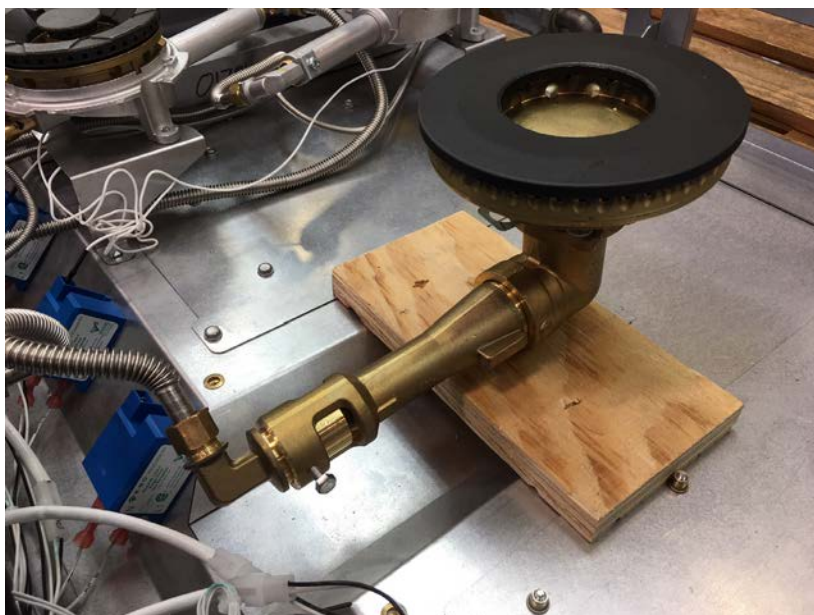

Also temporarily return all the burner rings and caps to the other burners.
(KRT365 shown)

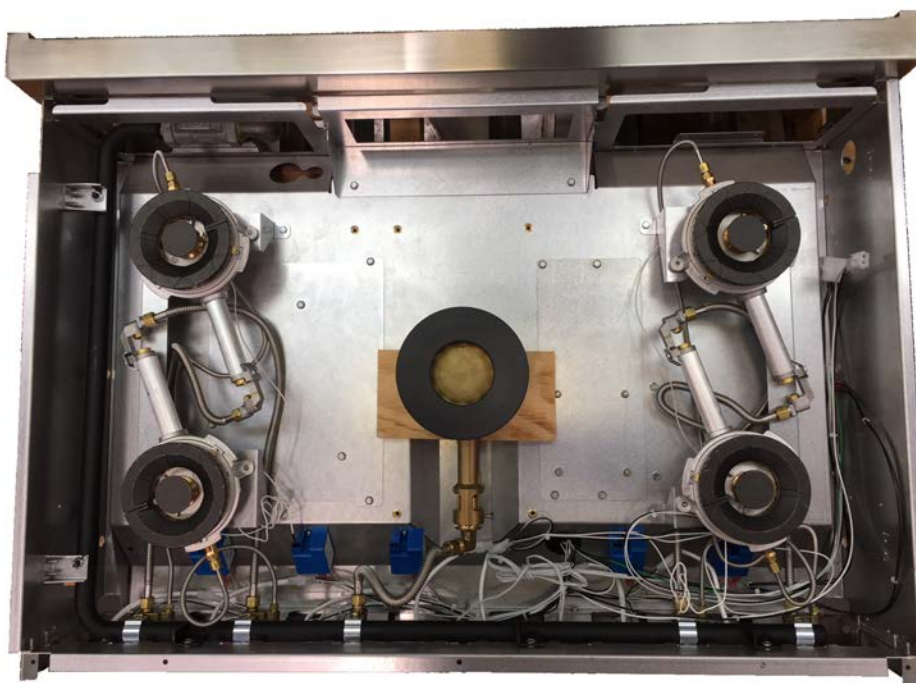

LEAK TESTING & ADJUSTMENT (cont.)

GENERAL

A complete gas tightness check must be performed of all gas-carrying components due to possible movement during installation, or excessive pressure unknowingly being applied to parts of the unit.

BEFORE TESTING

- DO NOT SMOKE while leak testing.
- Never leak test with an open flame.
- Make a soap solution of one part liquid detergent and one part water, for leak testing purposes.
- Apply the solution to the gas fittings by using a spray bottle, a brush or small sponge.
- For LP units, always check with a full LP cylinder.
- Check for adequate inlet gas pressure - 7" w.c. for Natural gas, 11" w.c. for LP gas.
Gas pressure from the regulator must be 5" w.c. for Natural gas and 10" w.c. for LP gas.

TO TEST TOP BURNERS

- Make sure all control valves are in the "OFF" position.
- Apply the soap solution described above to all fittings, flex hoses, etc.
- Turn the gas supply ON.
- CHECK ALL CONNECTIONS WHERE YOU APPLIED THE SOAP SOLUTION! Check from the supply line, up to and including the manifold pipe assembly, regulator, etc. Check ALL the hoses from end to end. Bending of the hoses may have resulted in small cracks in the hoses which must be found. Apply the soapy solution liberally to detect any leaks. If hoses are cracked, you will need to replace them.
- Soap bubbles will appear where a leak is present. If a leak is present, immediately turn off gas supply, tighten any leaking fittings, turn the gas supply back on, and recheck.
- If you cannot stop a gas leak, turn off the gas supply and call the dealer where you purchased your appliance.
- DO NOT USE THE APPLIANCE UNTIL ALL CONNECTIONS HAVE BEEN CHECKED AND DO NOT LEAK!

Once the leak check is done and there are no leaks, proceed to re-install all the top burner sheetmetal parts, LED boards, etc. that were previously removed in steps 1-7. Don't forget to re-connect the ignition wire for the center burner (if equipped).

FOR MODELS WITH GRIDDLES, PROCEED TO **LEAK TESTING GRIDDLE**.

FOR MODELS FEATURING GAS OVEN BURNERS, PROCEED TO **LEAK TESTING OVEN BURNERS**.

If you do not have a griddle or gas oven burners, restore the electrical power to the unit. Make sure to turn the gas shut-off valve to the open position.

NOTICE

All the control knobs must be in the OFF position to prevent unintended operation at power up.

Return all the burner rings and caps as shown here. Ensure the sealed burner heads are properly installed and seated on the burner base as shown. There are notches on the burner base and cross ring to help with alignment. The outer burner head features a long slot on the top of the head which aligns with the spark igniter. Assembly of the single-flow burner head is similar.

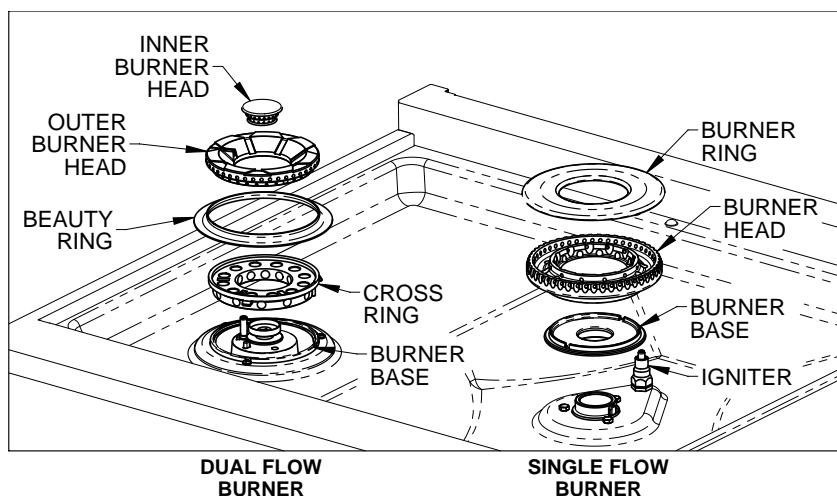

LEAK TESTING & ADJUSTMENT (cont.)

Verify ignition at each burner. Igniter will make a clicking sound until the flame lights within 4 seconds, then the clicking will stop. Check flame characteristics at each burner per the descriptions below. Flames should be stable and not dance or lift off the burner ports. Flame may need to burn for a few minutes to purge the gas lines of impurities. These appear as intermittent orange tips or even tiny sparks in the flame. This is normal and the flame will eventually stabilize like those shown in the image below.

If after a few minutes the flames continue to burn mostly yellow, verify that the burner head is properly installed on the base, then retest. Use caution when handling the burner heads. They can be very hot.

Turn down the control knob to the simmer setting to check function.

Check each burner individually, then check they operate satisfactorily with other burners on.

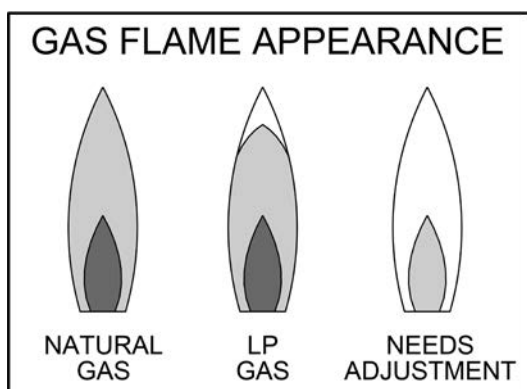

Light blue flame - Natural gas normal flame

Light blue flame with yellow tips - LP gas normal flame

Yellow flame - Needs adjustment

LEAK TESTING GRIDDLE

- Make sure the flex hose leading to the orifice has been tightened.
- Make sure all control valves are in the "OFF" position.
- Apply the soap solution to all fittings, flex hoses, etc.
- Turn the gas supply ON.
- Turn on the power. Set the griddle control knob to 350°F. The igniter will glow continuously and the solenoid gas valve will open in about 30-40 seconds, igniting the burner.

USE CAUTION - VERY HOT - BURN HAZARD

- CHECK ALL CONNECTIONS WHERE YOU APPLIED THE SOAP SOLUTION! Check ALL the hoses from end to end. Bending of the hoses may have resulted in small cracks in the hoses which must be found. Apply the soapy solution liberally to detect any leaks. If hoses are cracked, you will need to replace them.
- Soap bubbles will appear where a leak is present. If a leak is present, immediately turn off gas supply, tighten any leaking fittings, turn the gas supply back on, and recheck.
- If you cannot stop a gas leak, turn off the gas supply and call the dealer where you purchased your appliance.
- DO NOT USE THE APPLIANCE UNTIL ALL CONNECTIONS HAVE BEEN CHECKED AND DO NOT LEAK!

If leak testing is done successfully, turn off the griddle and allow everything to cool. Then replace the metal cover removed in step 20, and re-install the griddle plate as well.

If you have a gas oven model, proceed to the next section. Otherwise, skip to the **LABEL** section.

LEAK TESTING & ADJUSTMENT *(cont.)*

LEAK TESTING OVEN BURNERS (KRG MODELS ONLY)



IF THE INFORMATION BELOW IS NOT FOLLOWED EXACTLY, A FIRE OR EXPLOSION MAY RESULT CAUSING PROPERTY DAMAGE, PERSONAL INJURY, OR DEATH.

- Make sure the flex hoses leading to the orifices were all tightened (upper, lower, and rear).
- Make sure all control valves are in the "OFF" position.
- Apply the soap solution to all fittings, flex hoses, etc.
- Turn the gas supply ON.

MAIN OVEN - LOWER BURNER

- Turn on the power. Open the oven door and place a small piece of tape on the door switch so the oven light can go off.
- Set the oven selector knob to BAKE .
- Set the temperature control knob to 350°F. From beneath, you may see the igniter glow continuously and the solenoid gas valve will open in about 30-40 seconds, igniting the burner. Close the oven door.
- **CHECK ALL CONNECTIONS WHERE YOU APPLIED THE SOAP SOLUTION!** Check ALL the hoses from end to end. Bending of the hoses may have resulted in small cracks in the hoses which must be found. Apply the soapy solution liberally to detect any leaks. If hoses are cracked, you will need to replace them.
- Soap bubbles will appear where a leak is present. If a leak is present, immediately turn off gas supply, tighten any leaking fittings, turn the gas supply back on, and recheck.
- If you cannot stop a gas leak, turn off the gas supply and call the dealer where you purchased your appliance.
- **DO NOT USE THE APPLIANCE UNTIL ALL CONNECTIONS HAVE BEEN CHECKED AND DO NOT LEAK!**

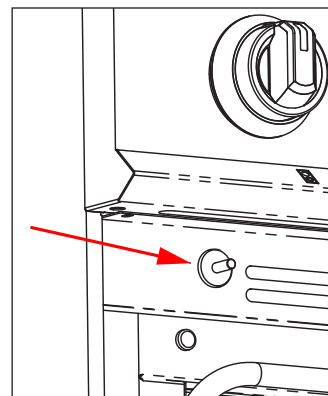

If leak testing is done for this burner, you may turn off this oven and proceed to the next step.

SMALL OVEN - LOWER BURNER - If you have a 48" range model, repeat this process for the small oven lower burner.

MAIN OVEN - UPPER BURNER

- Turn on the power. Open the oven door and place a small piece of tape on the door switch so the oven light can go off.
- Set the oven selector knob to BROIL .
- Set the temperature control knob to BROIL. From inside the oven cavity, you will see the igniter glow continuously and the solenoid gas valve will open in about 30-40 seconds, igniting the burner. Close the oven door.
- **CHECK ALL CONNECTIONS WHERE YOU APPLIED THE SOAP SOLUTION!** (at rear of appliance) Check ALL the hoses from end to end. Bending of the hoses may have resulted in small cracks in the hoses which must be found. Apply the soapy solution liberally to detect any leaks. If hoses are cracked, you will need to replace them.
- Soap bubbles will appear where a leak is present. If a leak is present, immediately turn off gas supply, tighten any leaking fittings, turn the gas supply back on, and recheck.
- If you cannot stop a gas leak, turn off the gas supply and call the dealer where you purchased your appliance.
- **DO NOT USE THE APPLIANCE UNTIL ALL CONNECTIONS HAVE BEEN CHECKED AND DO NOT LEAK!**

If leak testing is done successfully, you may turn off this oven and remove the tape from the door switch. You may re-install the kick plate removed in step 13 and the rear cover removed in step 18.

ORIFICE CHARTS - GRIDDLE/OVEN SECTIONS

Use the chart below to select the appropriate orifice size for your gas type / altitude. The part number for the orifice is given in the table below.

BURNER LOCATION	BURNER OUTPUT (BTU/hr)		ALTITUDE	Spud Orifice for IR Burner 002865-xxx		Hood Orifice for Tubular Burner 000293-xxx	
	NG	LP		NG	LP	NG	LP
Griddle	23000	23000	Sea Level - 1999 ft (600m)	050	056	-	-
Main Oven - Upper	23000	23000		047	055	-	-
Main Oven - Lower	23000	23000		-	-	037	052
Small Oven	15500	15500		-	-	048	056
Griddle	23000	23000	H1 2000 - 5999 ft (600 - 1800m)	051	057	-	-
Main Oven - Upper	23000	23000		049	055	-	-
Main Oven - Lower	23000	23000		-	-	039	053
Small Oven	15500	15500		-	-	049	057
Griddle	23000	23000	H2 6000 - 10000 ft (1800 - 3050m)	052	059	-	-
Main Oven - Upper	23000	23000		050	056	-	-
Main Oven - Lower	23000	23000		-	-	042	054
Small Oven	15500	15500		-	-	051	059

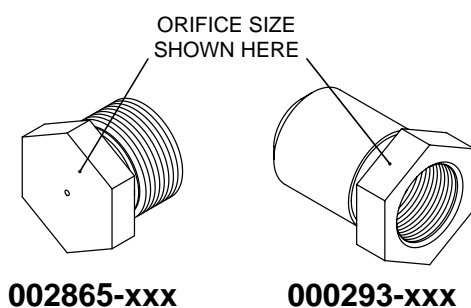

FINAL STEPS

With all leak detection complete, you may now re-install any remaining covers, etc. in the reverse order they were removed. Carefully move the range back into position. Be sure the anti-tip bracket at the rear of the range is fully engaged.

LABEL

After conversion, the label provided in the kit must be attached to the unit. For the range, affix in the upper right corner as shown. For the rangetop, affix underneath the unit next to the existing rating label. The qualified service technician will fill in the Gas Type, Manifold Pressure, and BTU Rates for each burner type (per the chart on page 6 and above). The technician should sign and date the label as well.

