

Broil King®

ASSEMBLY MANUAL & PARTS LIST - MANUEL DE MONTAGE & LISTE DE PIÈCES - MANUAL DE ARMADO Y LISTA DE PARTES

Broil King®
945050



Broil King®
948050



RETAIN FOR FUTURE REFERENCE - VEUILLEZ CONSERVER POUR REFERENCE ULTERIEURE - CONSERVER PARA FUTURAS CONSULTAS



HARDWARE INCLUDED / MATERIAL INCLUS / EQUIPOS INCLUIDO



Y-12859		X16	G01CH038		X2
SP910-21		X14	535091		X2
Y-12875		X2	Y-11698		X2
63599-73		X4			



TOOLS REQUIRED / OUTILS NECESSAIRES / HERRAMIENTAS NECESARIAS



#3 PHILLIPS

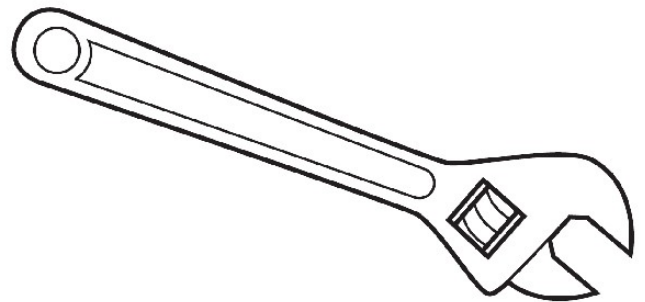
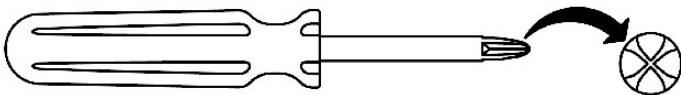

1

(12)

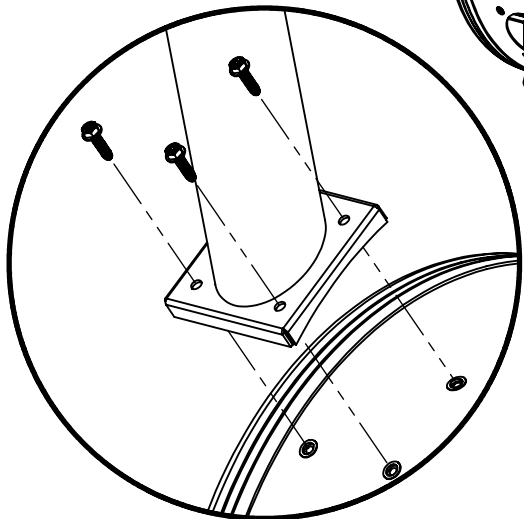
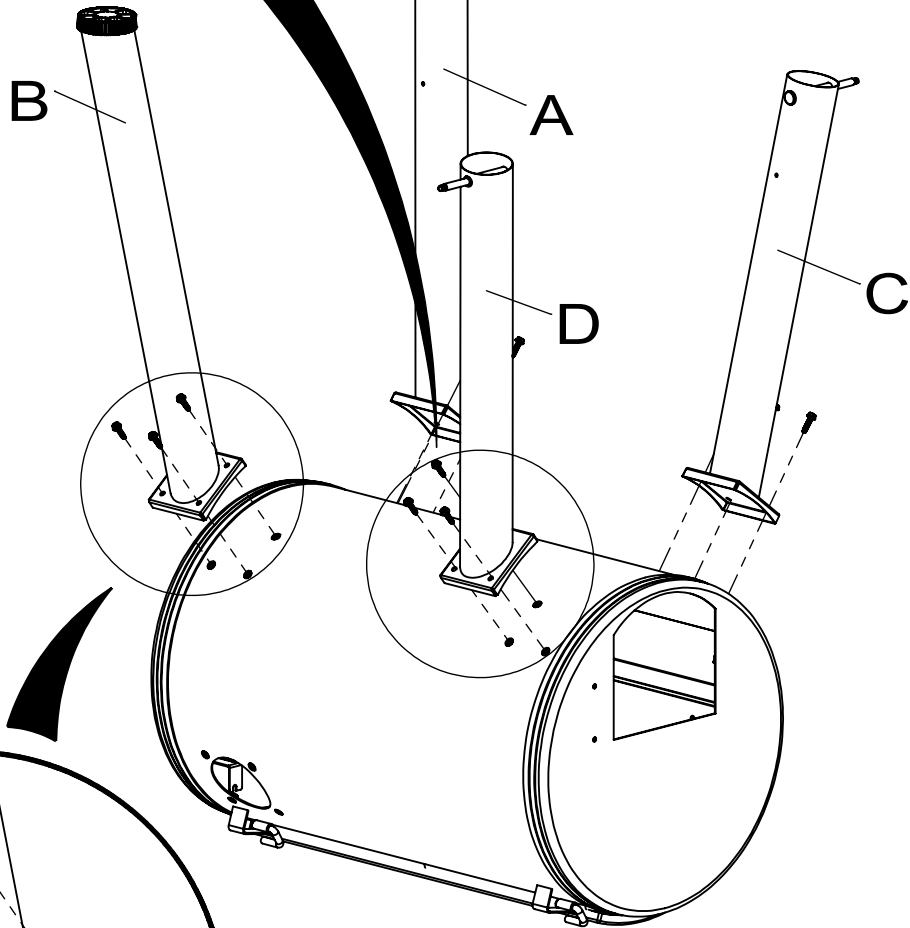
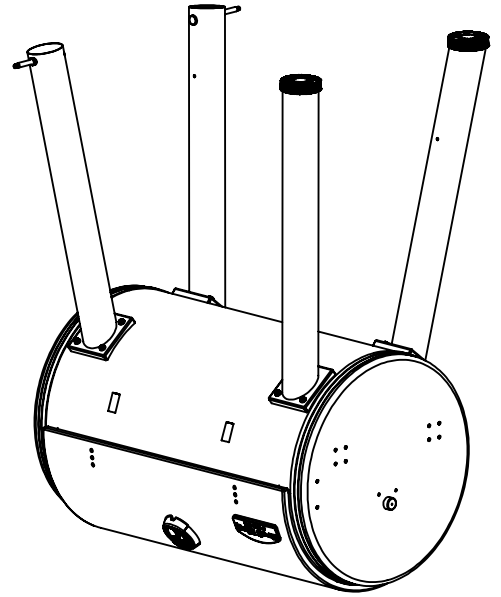
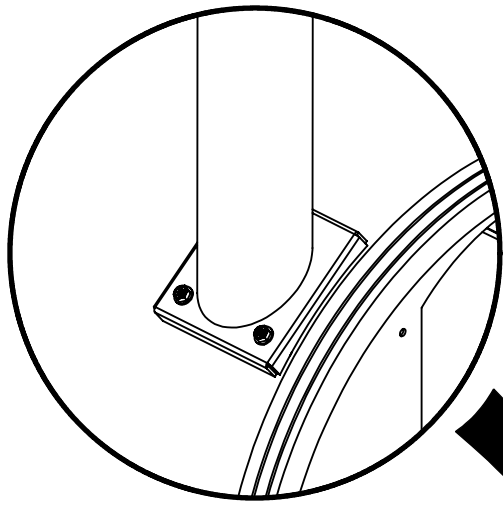
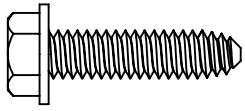

2

(4)

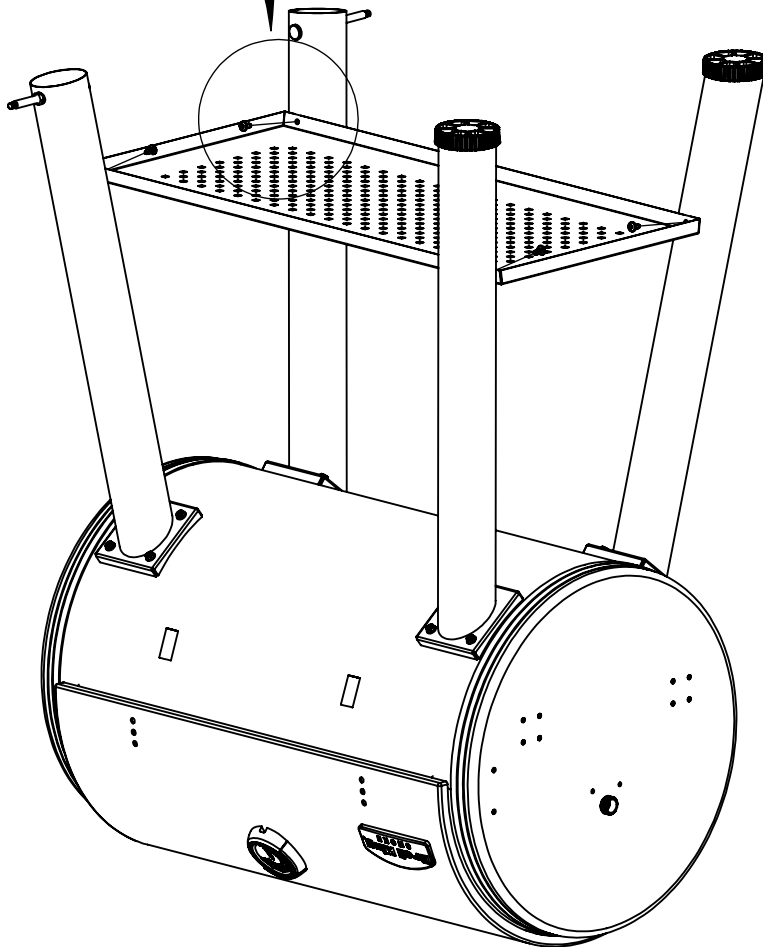
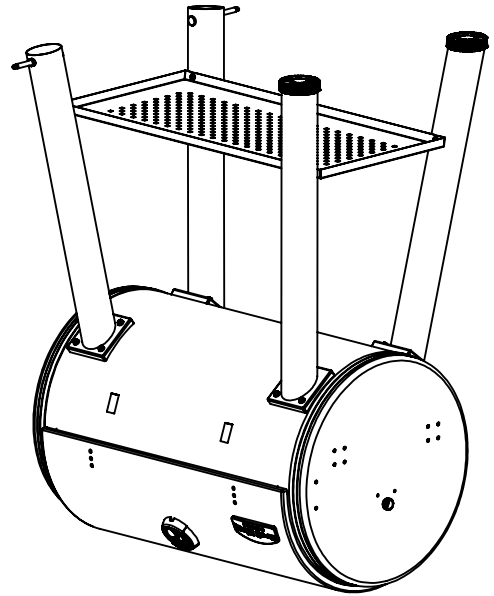
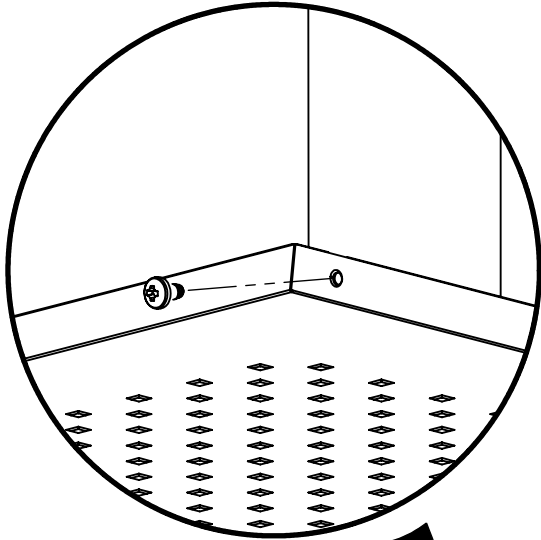
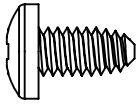

3

(2)

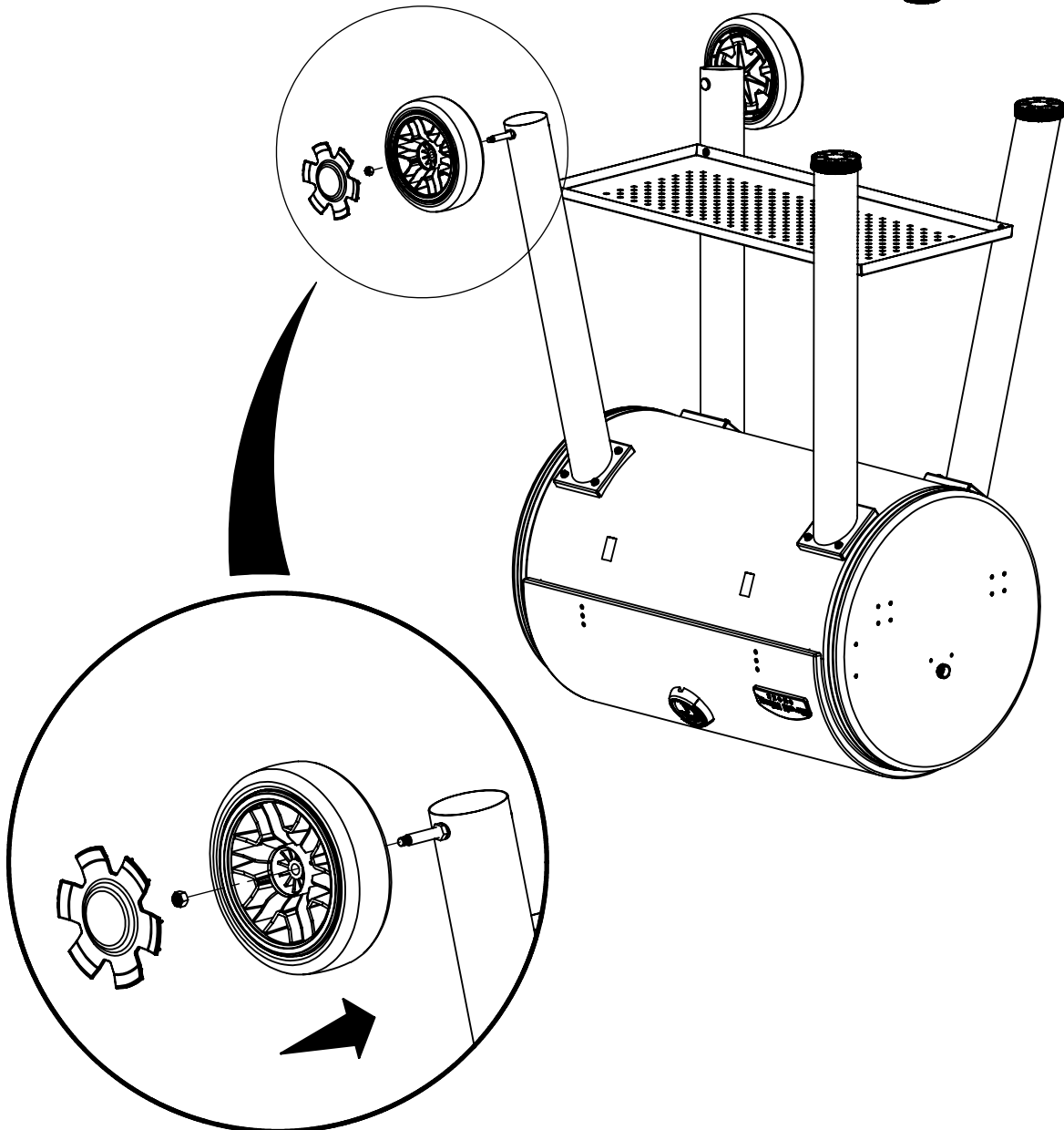
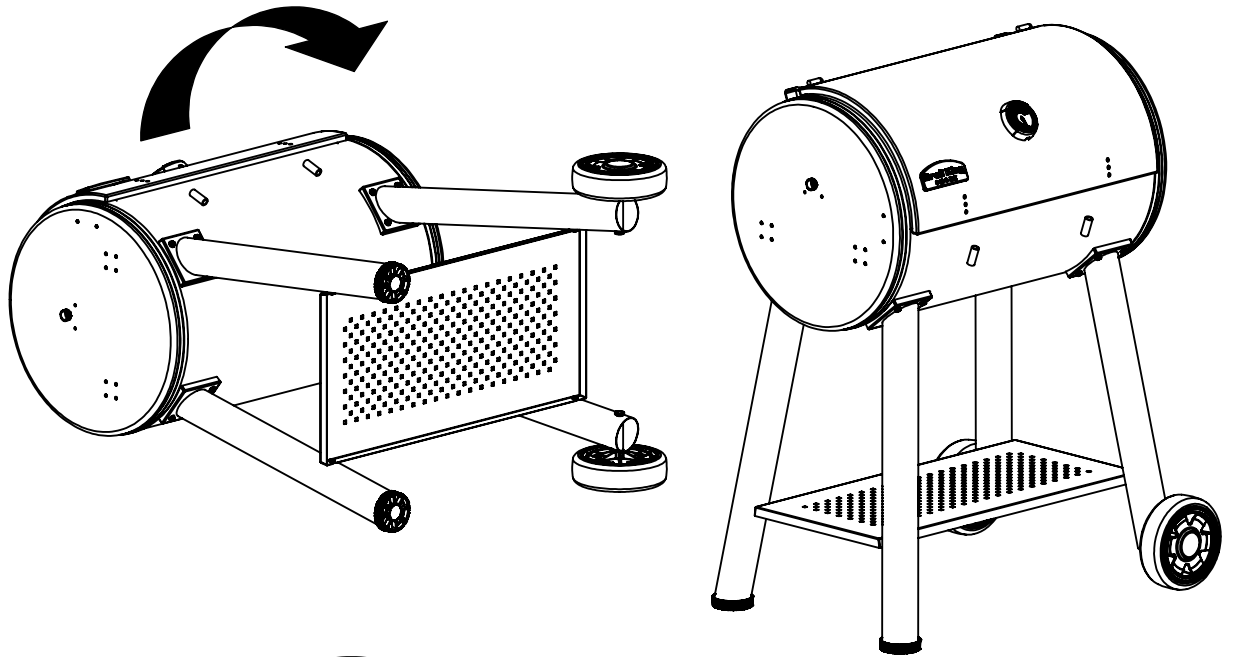
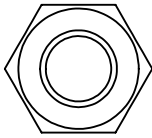

4

(2)

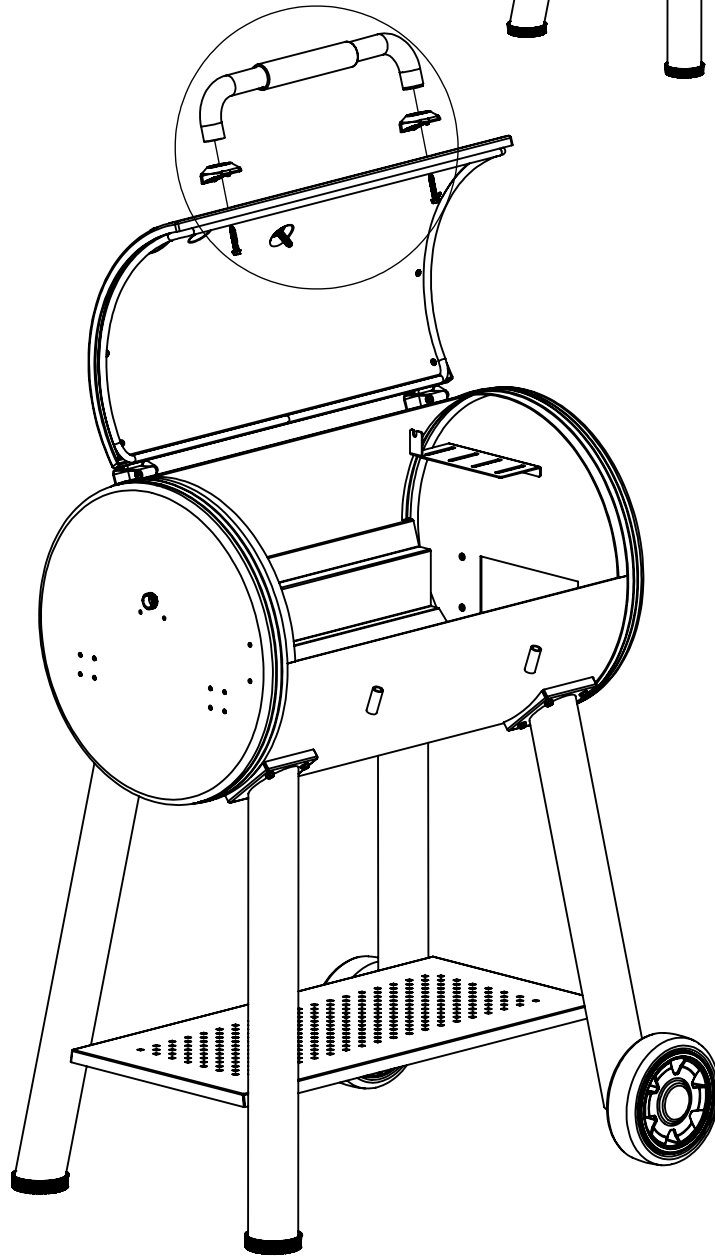
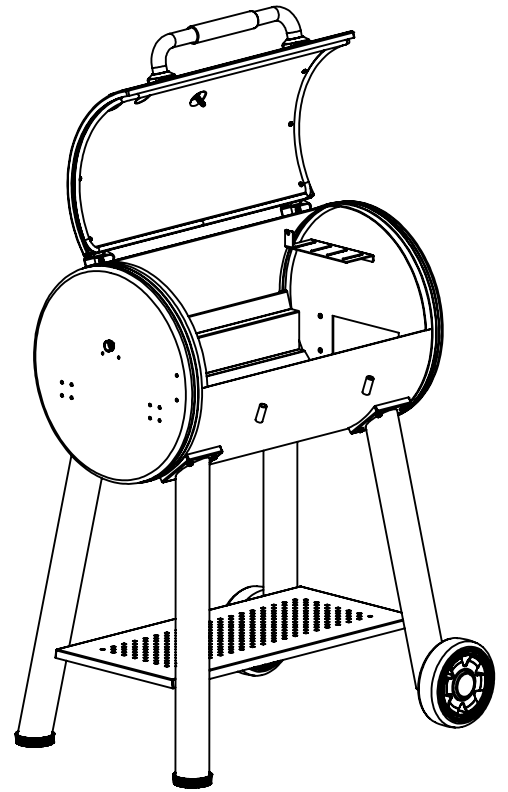
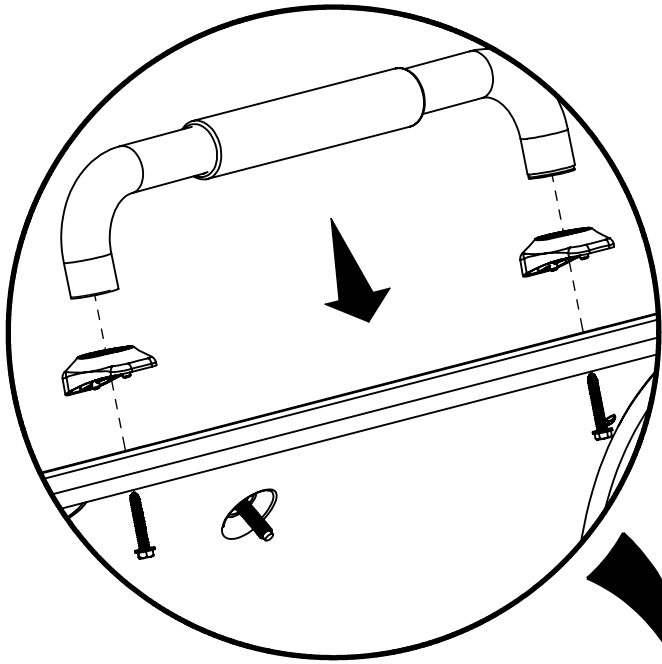
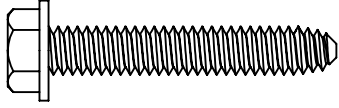

5

(8)

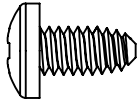

(2)

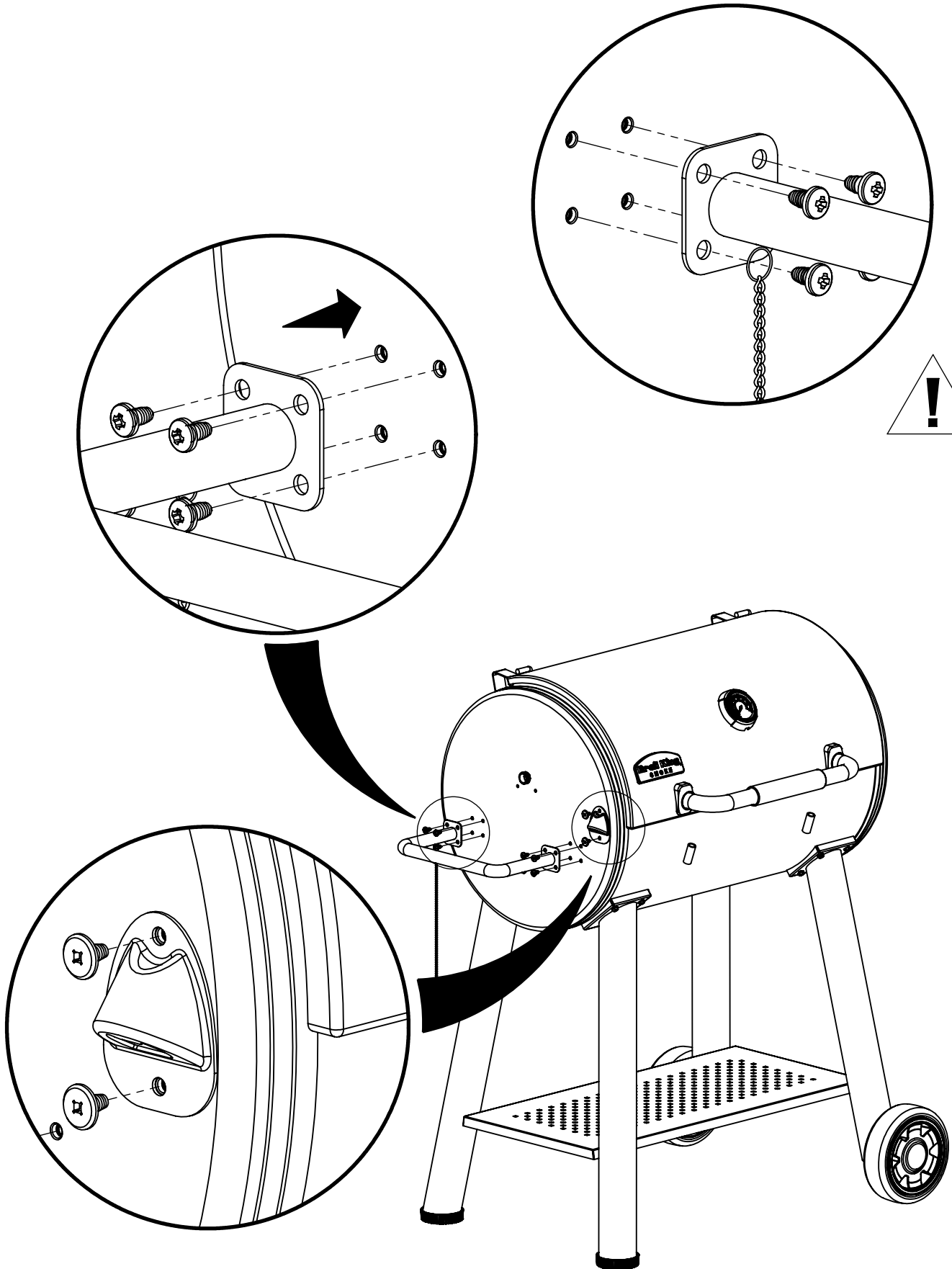
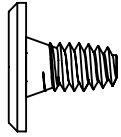

6

(4)

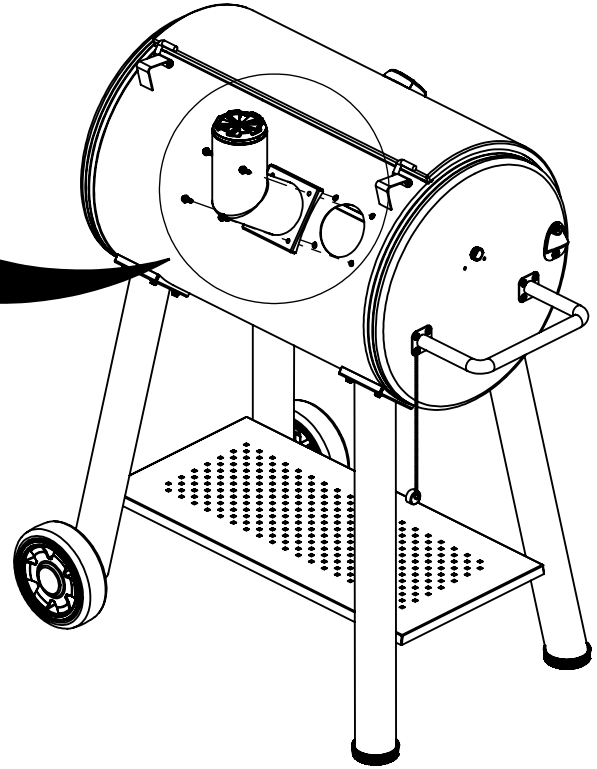
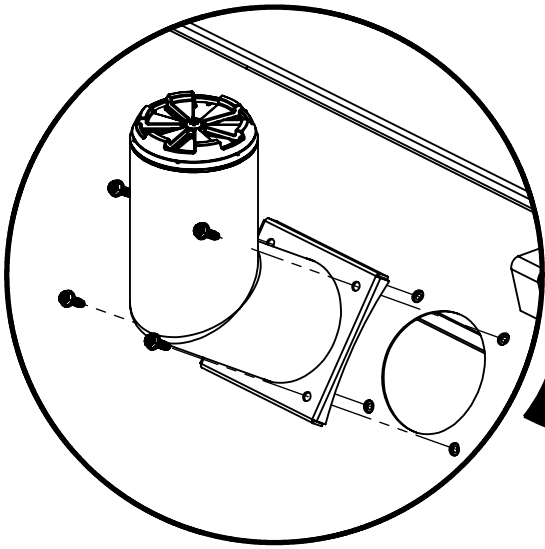
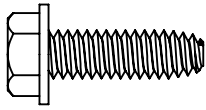

7

(2)

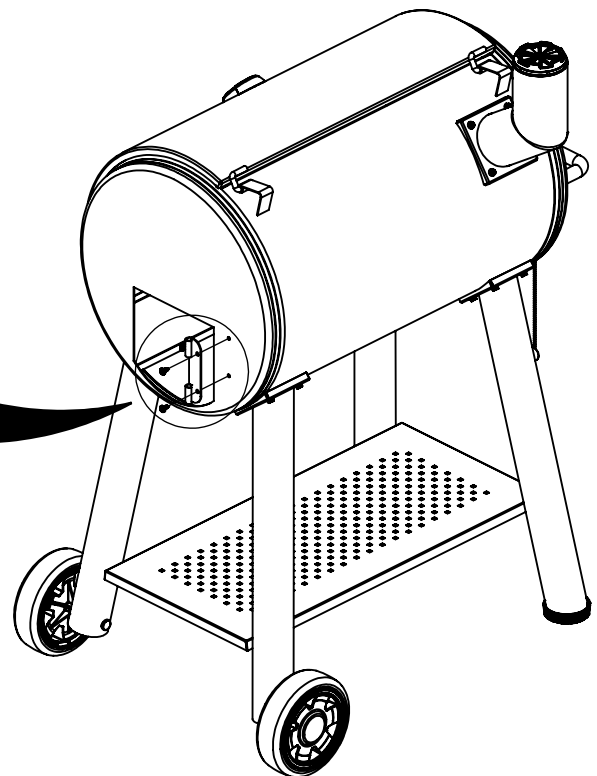
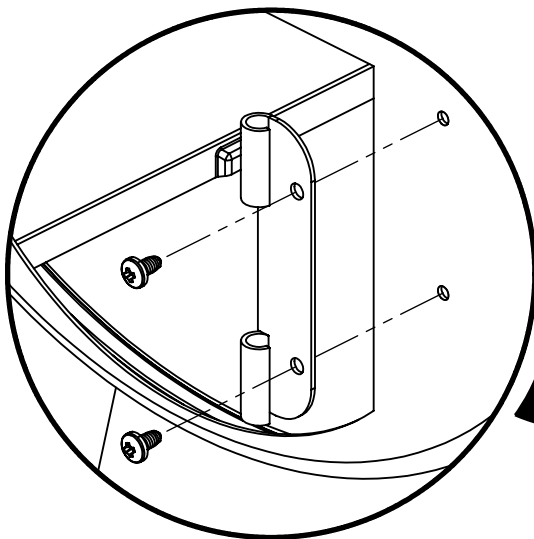
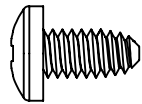

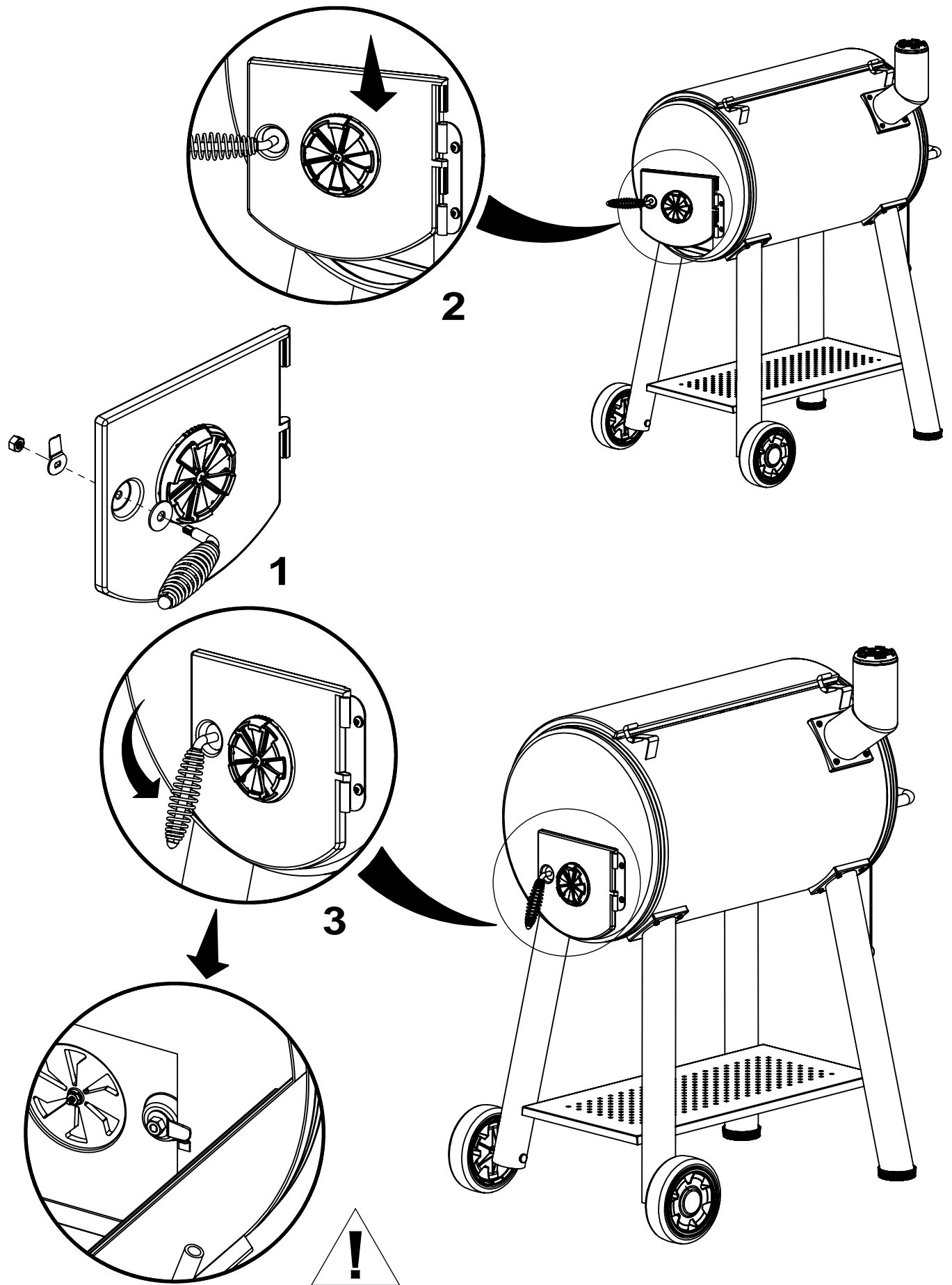

9

(4)

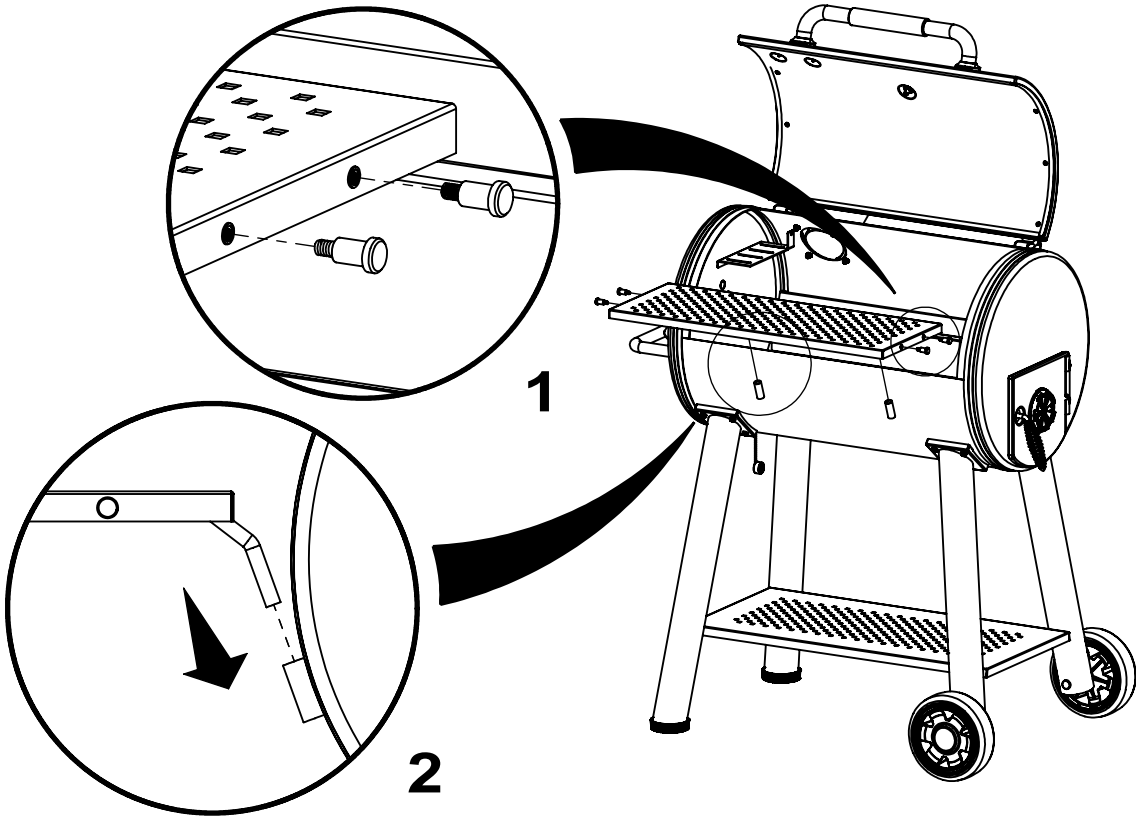
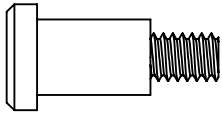

10

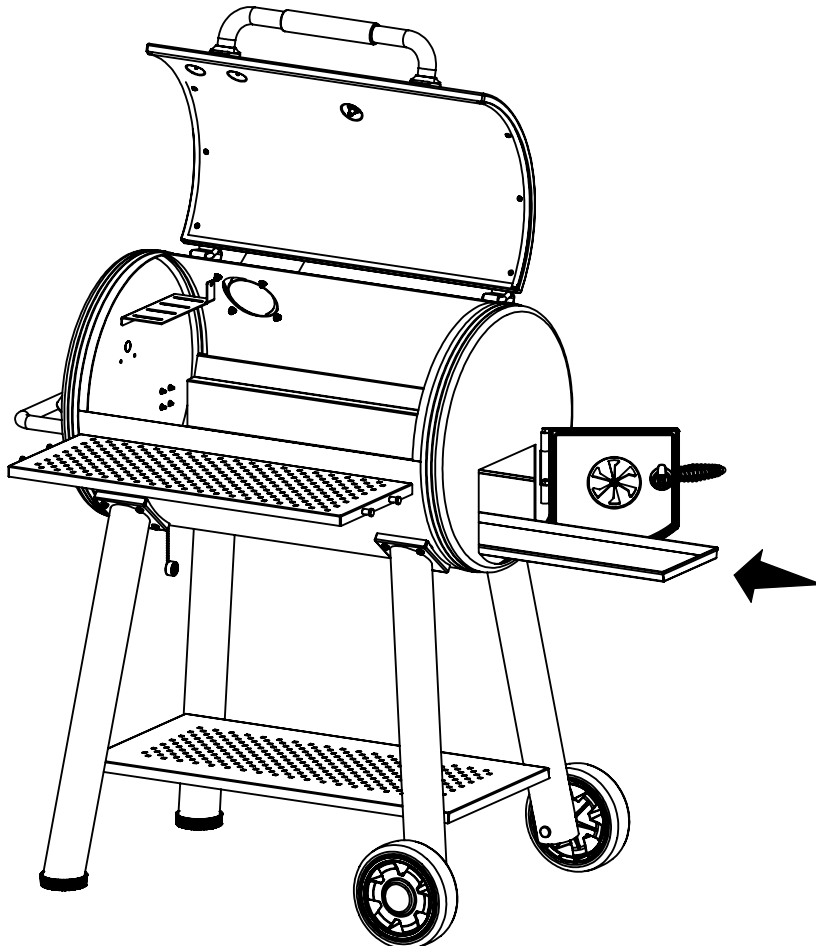

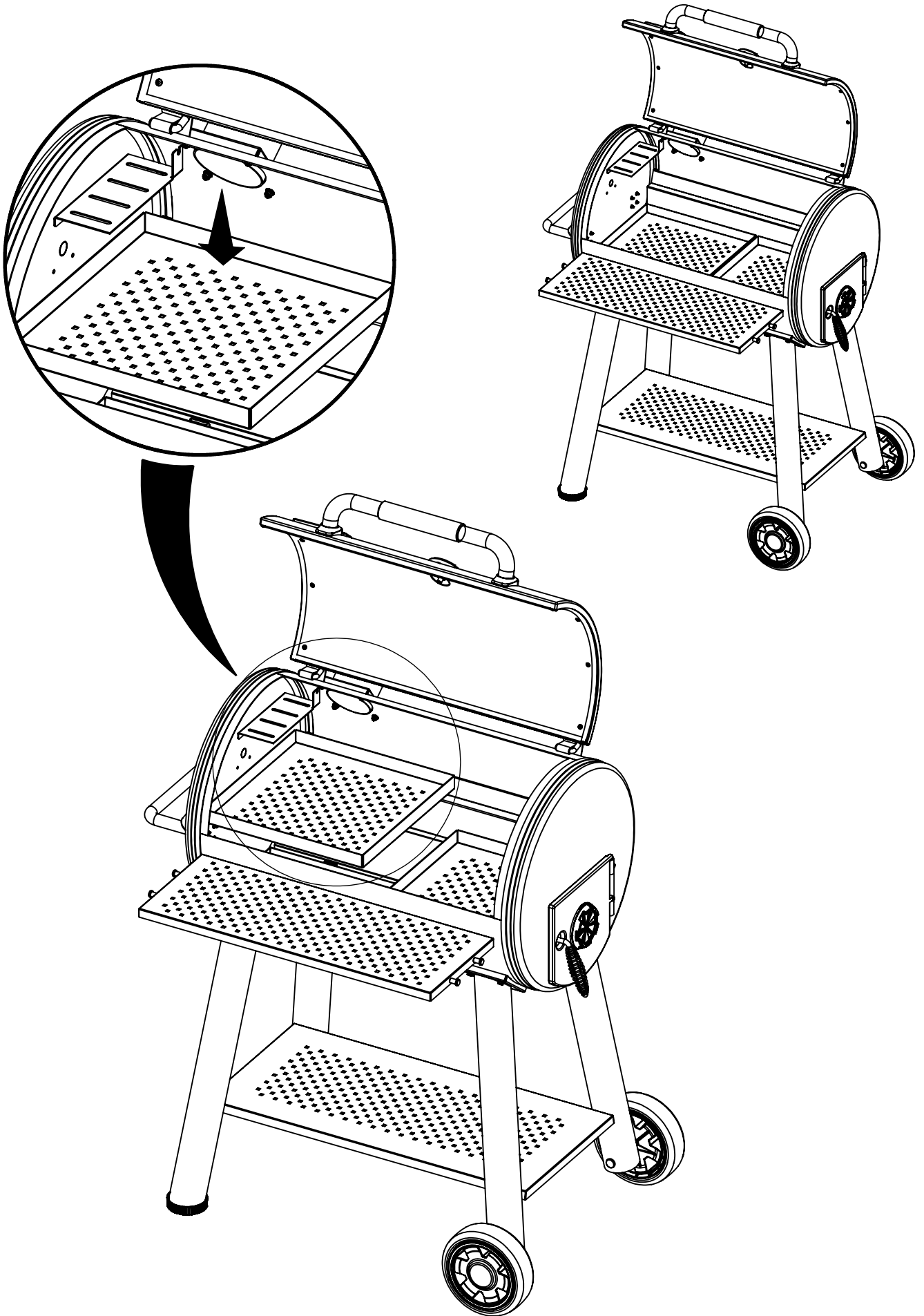

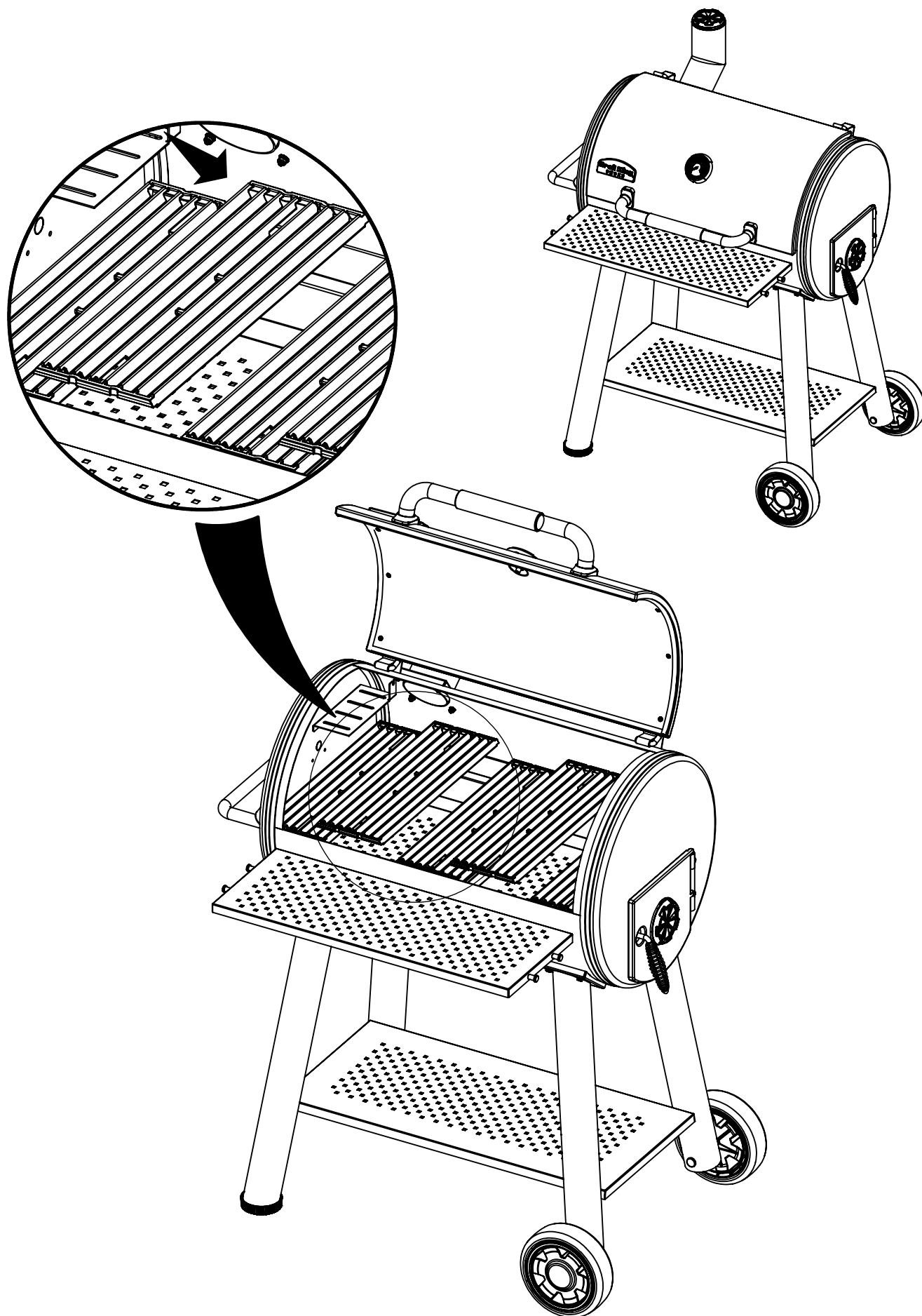

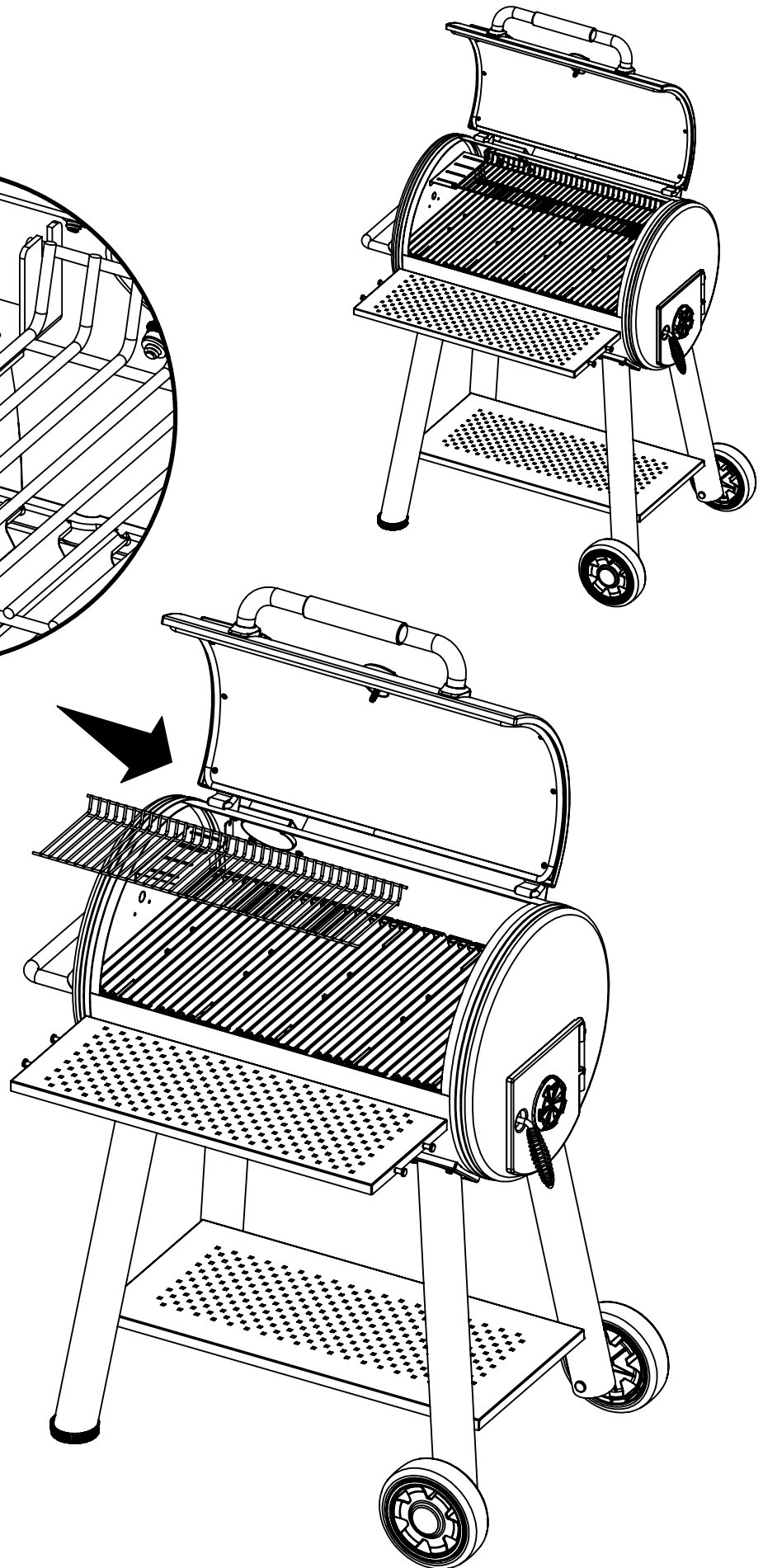
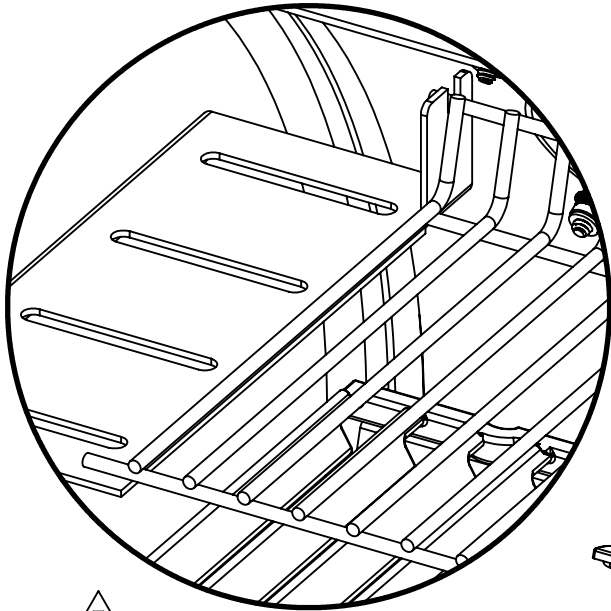

14

(2)

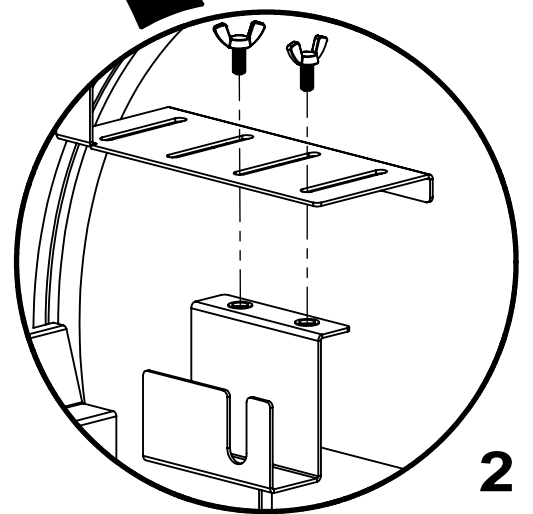
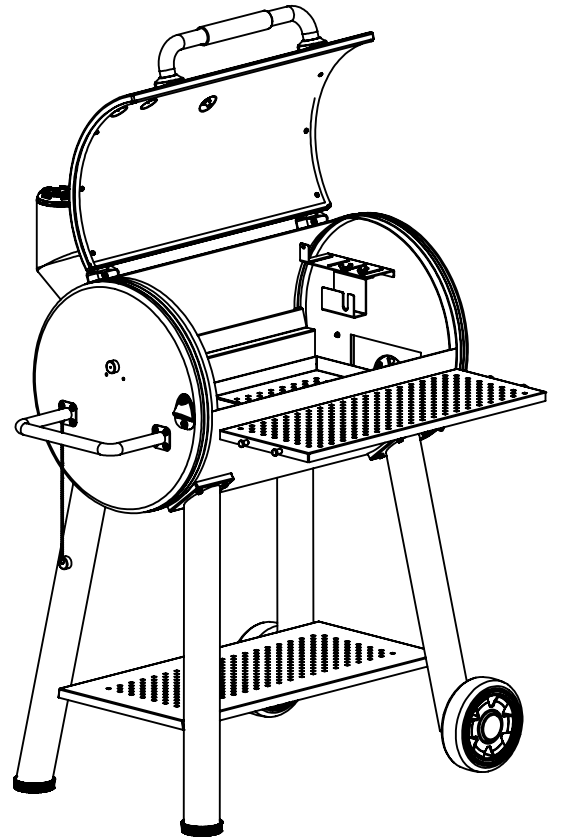
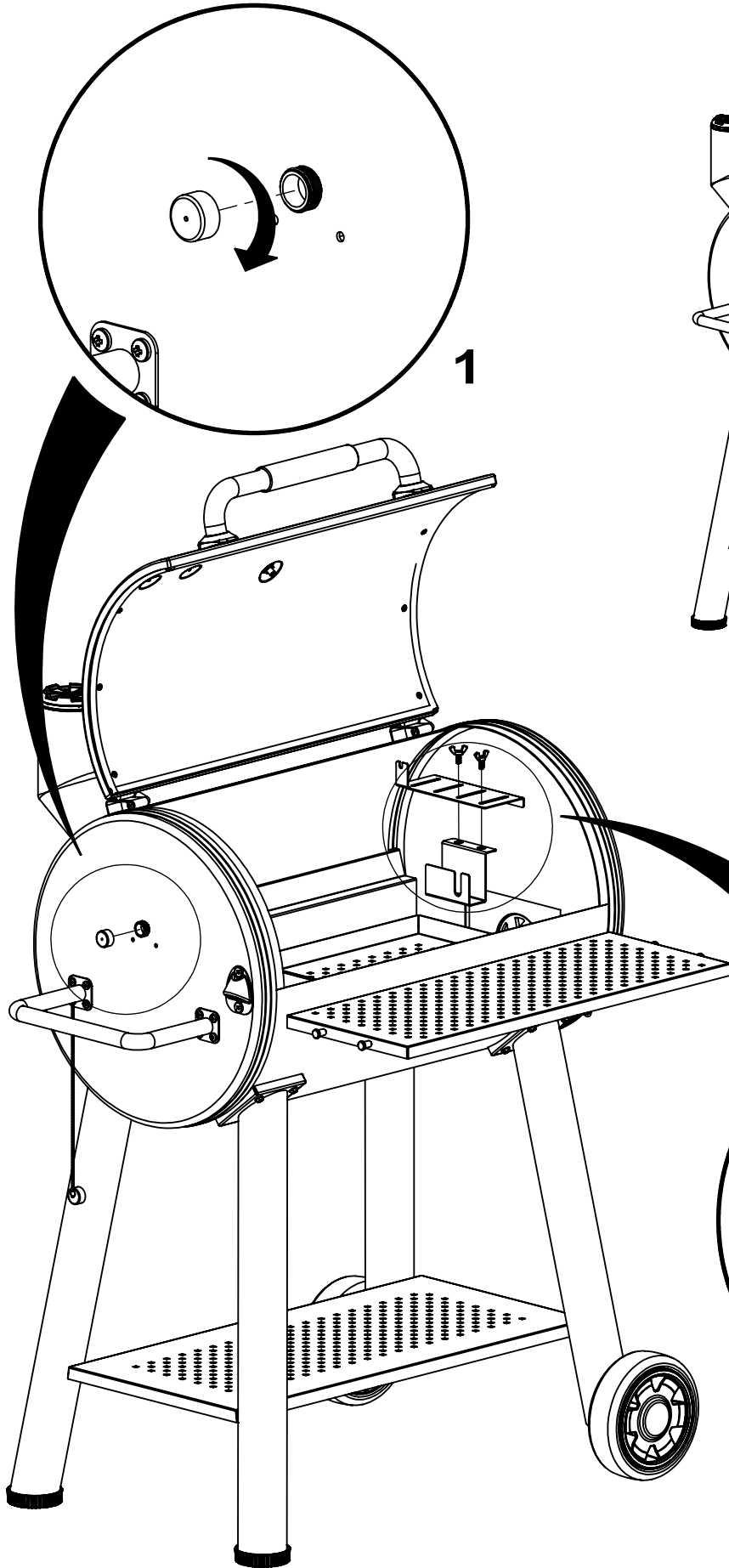
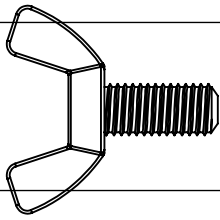

PARTS LIST / LISTE DES PIÉCES / LISTA DE PARTES

KEY#	ITEM#	DESCRIPTION (ENGLISH)	DESCRIPTION(FRENCH)	DESCRIPTION(SPANISH)	DESCRIPTION(GERMAN)	945050	948050
1	44302-10A	MAIN LID WELD ASSEMBLY - 625	ASSEMBLAGE DE SOUDURE DU COUVERCLE PRINCIPAL - 625	MECANISMO DE LA TAPA PRINCIPAL - 625	GESCHWEISSTER HAUPTDECKEL MONTAGE - 625	-	1
	44305-10A	MAIN LID WELD ASSEMBLY - 500	ASSEMBLAGE DE SOUDURE DU COUVERCLE PRINCIPAL - 500	MECANISMO DE LA TAPA PRINCIPAL - 500	GESCHWEISSTER HAUPTDECKEL MONTAGE - 500	1	-
2	44599-10BK	SMOKER NAMEPLATE	PLAQUE SIGNALÉTIQUE DU FUMOIR	PLACA DE IDENTIFICACIÓN	RAUCHEROFEN TYPENSCHILD	1	1
3	54009-94	HANDLE SEAT	SIÈGE DE LA POIGNÉE	BASE DEL MANGO	GRIFFHALTERUNG	2	2
4	24003-12A	LID HANDLE ASSEMBLY	ASSEMBLAGE DE LA POIGNÉE DU COUVERCLE	MANIJA DE LA TAPA	DECKELGRIFF MONTAGE	2	2
5	44479-20	HEAT INDICATOR LARGE	GROS INDICATEUR DE CHALEUR	INDICADOR GRANDE DE TEMPERATURA	GROSSE WÄRMEANZEIGE	1	1
6	44499-20	CAST BEZEL-THERMOMETER	THERMOMÈTRE À FACETTE BÉZEL	BORDE DEL TERMOMETRO	BEZEL THERMOMETER	1	1
7	22005-281	CAST COOKING GRID	GRILLE DE CUISSON EN FONTE	REJILLA DE COCCIÓN DE HIERRO FUNDIDO	GUSSEISERNER GRILLROST	4	5
8	42302-92	SMOKE DIFFUSER - 625	DIFFUSEUR DE FUMÉE - 625	DIFFUSOR DE HUMO - 625	RAUCHDIFFUSOR - 625	-	2
	42305-92	SMOKE DIFFUSER - 500	DIFFUSEUR DE FUMÉE - 500	DIFFUSOR DE HUMO - 500	RAUCHDIFFUSOR - 500	2	-
9	42302-93	ASH TRAY-MAIN - 625	CENDRIER - PRINCIPAL - 625	BANDEJA PARA CENIZAS - PRINCIPAL - 625	HAUPT-ASCHER - 625	-	1
	42305-93	ASH TRAY-MAIN - 500	CENDRIER - PRINCIPAL - 500	BANDEJA PARA CENIZAS - PRINCIPAL - 500	HAUPT-ASCHER - 500	1	-
10	44310-26	DAMPER TOP	HAUT DU VOLET	PARTE SUPERIOR DE LA VENTILACIÓN	OBERER ZUGREGLER	2	2
11	44310-25	DAMPER BOTTOM	BAS DU VOLET	PARTE INFERIOR DE LA VENTILACIÓN	UNTERER ZUGREGLER	1	1
12	44302-30B	CHIMNEY WELD ASSEMBLY	ASSEMBLAGE DE SOUDURE DE LA CHEMINÉE	CHIMENEA	GESCHWEISSTER RAUCHABZUG MONTAGE	1	1
13	42302-60A	FRONT SHELF WELD ASSEMBLY - 625	ASSEMBLAGE DE SOUDURE DE LA TABLETTE AVANT - 625	ESTANTE DELANTERO - 625	GESCHWEISSTE FRONTABLAGE MONTAGE - 625	-	1
	42306-60A	FRONT SHELF WELD ASSEMBLY - 500	ASSEMBLAGE DE SOUDURE DE LA TABLETTE AVANT - 500	ESTANTE DELANTERO - 500	GESCHWEISSTE FRONTABLAGE MONTAGE - 500	1	-
14	42302-01	BODY-LARGE WELD ASSEMBLY - 625	ASSEMBLAGE DE SOUDURE DU BÂTI PRINCIPAL - 625	CUERPO - GRANDE - 625	GESCHWEISSTES GROSSES GEHÄUSE MONTAGE - 625	-	1
	42305-01A	BODY-LARGE WELD ASSEMBLY - 500	ASSEMBLAGE DE SOUDURE DU BÂTI PRINCIPAL - 500	CUERPO - GRANDE - 500	GESCHWEISSTES GROSSES GEHÄUSE MONTAGE - 500	1	-
15	42302-80	SIDE HANDLE WELD ASSEMBLY	ASSEMBLAGE DE SOUDURE DE LA POIGNÉE LATÉRALE	MANGO LATERAL	GESCHWEISSTER SEITENGRIF MONTAGE	1	1
16	42302-68	SIDE DOOR BRACKET	SUPPORT DE LA PORTE LATÉRALE	SOPORTE DE LA PUERTA LATERAL	SEITENTÜRHALTERUNG	1	1
17	42041-13A	WINDOW HANDLE ASSEMBLY	ASSEMBLAGE DE LA POIGNÉE DE FENÊTRE	MANIJA DE LA VENTANA	FENSTERGRIF MONTAGE	1	1
18	42302-65B	SIDE DOOR WELD ASSEMBLY-RH	ASSEMBLAGE DE SOUDURE DE LA PORTE LATÉRALE - DROIT	PUERTA LATERAL - DERECHA	GESCHWEISSTE SEITENTÜR MONTAGE-RH	1	1
19	42041-14	WINDOW HANDLE CLIP	ATTACHE DE LA POIGNÉE DE FENÊTRE	GANCHO DE LA MANIJA DE LA VENTANA	FENSTERGRIF-KLEMMME	1	1
20	SP235-6	BOTTLE OPENER	OUVRE-BOUTEILLE	ABRIDOR DE BOTTELLAS	FLASCHENÖFFNER	1	1
21	42302-40	LEG REAR WELD ASSEMBLY-LH	ASSEMBLAGE DE SOUDURE DU PIED ARRIÈRE - GAUCHE	PATA POSTERIOR IZQUIERDA	GESCHWEISSTE HINTERBEIN MONTAGE-LH	1	1
22	42302-20	LEG FRONT WELD ASSEMBLY-LH	ASSEMBLAGE DE SOUDURE DU PIED AVANT - GAUCHE	PATA DELANTERA IZQUIERDA	GESCHWEISSTE VORDERBEIN MONTAGE-LH	1	1
23	42302-30	LEG REAR WELD ASSEMBLY-RH	ASSEMBLAGE DE SOUDURE DU PIED ARRIÈRE - DROIT	PATA POSTERIOR DERECHA	GESCHWEISSTE HINTERBEIN MONTAGE-RH	1	1
24	42302-10	LEG FRONT WELD ASSEMBLY-RH	ASSEMBLAGE DE SOUDURE DU PIED AVANT - DROIT	PATA DELANTERA DERECHA	GESCHWEISSTE VORDERBEIN MONTAGE-RH	1	1
25	41302-41	CART BASE - 625	BASE DU CHARIOT - 625	BASE DEL CARRITO - 625	FAHRUNTERSATZ - 625	-	1
	41305-41	CART BASE - 500	BASE DU CHARIOT - 500	BASE DEL CARRITO - 500	FAHRUNTERSATZ - 500	1	-
26	G01CP009	WHEEL HUB CAP	CAPUCHON DU MOYEU DE ROULETTE	TAPA DEL EJE DE LA RUEDA	RÄDERMONTAGE GAP	2	2
27	G01A0009	WHEEL ASSEMBLY	ASSEMBLAGE DE ROUES	MECANISMO DE LAS RUEDITAS	RÄDERMONTAGE	2	2
28	45304-70	GLASS FIBRE - 625	FIBRE DE VERRE	FIBRA DE VIDRIO	GLASFASER	-	1
	45306-70	GLASS FIBRE - 500	FIBRE DE VERRE	FIBRA DE VIDRIO	GLASFASER	1	-
29	52005-99	WARMING GRID - 625	GRILLE DE RÉCHAUFFEMENT	REJILLA CALENTADORA	ERWÄRMUNGSGITTER	-	1
	52004-99	WARMING GRID - 500	GRILLE DE RÉCHAUFFEMENT	REJILLA CALENTADORA	ERWÄRMUNGSGITTER	1	-
30	45304-53A	PRESSING RIVET COVER ASSEMBLY	PRESSING RIVET COVER	PRESSIONANDO LA CUBIERTA DEL RIVET	PRESSEN NIETENABDECKUNG	1	1
31	SP910-21	BOLT 0.25-20X0.5	BOULON 0,25-20 X 0,5	PERNO 0,25-20X0,5	SCHRAUBEBOLEN 0,25-20X0,5	16	16
32	63599-70	VENT BOLT	BOULON À ÉVENT	PERNO DE VENTILACIÓN	ENTLÜFTUNGSSCHRAUBE	2	2
33	Y-12859	SCREW 1/4-20X1	VIS 1/4-20 X 1	TORNILLO 1/4-20X1	1/4-20X1 SCHRAUBE	16	16
34	63599-73	CARRIAGE BOLT TOOL HOOK	CROCHET OUTIL-BOULON DE TRANSPORT	PERNO DE CABEZA DE HONGO - GANCHO PARA HERRAMIENTAS	SCHLOSSSCHRAUBE FÜR BESTECKHACKEN	4	4
35	535091	SCREW 1/4-20X12	VIS 1/4-20 X 12	TORNILLO 1/4-20X12	1/4-20X12 SCHRAUBE	2	2
36	Y-11793	NUT - 1/4	ÉCROU - 1/4	TUERCA - #1/4	MUTTER - 1/4	1	1
37	G01CH038	LOCK NUT M8	CONTRE-ÉCROU M8	TUERCA DE SEGURIDAD M8	SICHERUNGSMUTTER	2	2
38	Y-11795	NUT - 5/16	ÉCROU - 5/16	TUERCA - #5/16	MUTTER - 5/16	1	1
39	41302-33	BALANCE FOOT	BALANCE PIED	BALANCE PIE	HANDGRIF	2	2
40	34201-009	HANDLE GRIP	POIGNÉE	EMPUÑADURA	BALANCEGRIF	1	1
41	45303-18A	ROTISSERIE SUPPORT	SOUTIEN DE ROTISSERIE	SOPORTE DE ESTILO ROTISSERIE	ROTISSERIE UNTERSTÜTZUNG	1	1
42	Y-11698	BUTTERFLY SCREW 1/4"X15	VIS BUTTERFLY	TORNILLO DE MARIPOSA	SCHMETTERLINGS-SCHRAUBE	2	2
43	Y-12875	SCREW 1/4-20X1.5	VIS 1/4-20 X 1.5	TORNILLO 1/4-20X1.5	1/4-20X1.5 SCHRAUBE	2	2
	948050-HP	HARDWARE PACK	ENSEMBLE DE LA QUINCAILLERIE	ACCESORIOS DE EMBALAJE	HARWARE-VERPACKUNG	1	1

