

Manhattan Fireplace

Model #: 082-xx-N-xx-LBNC

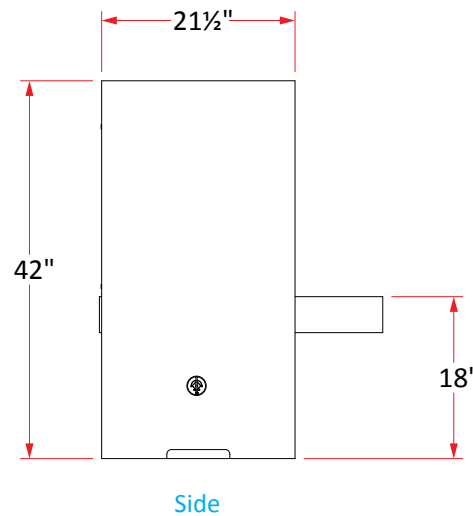
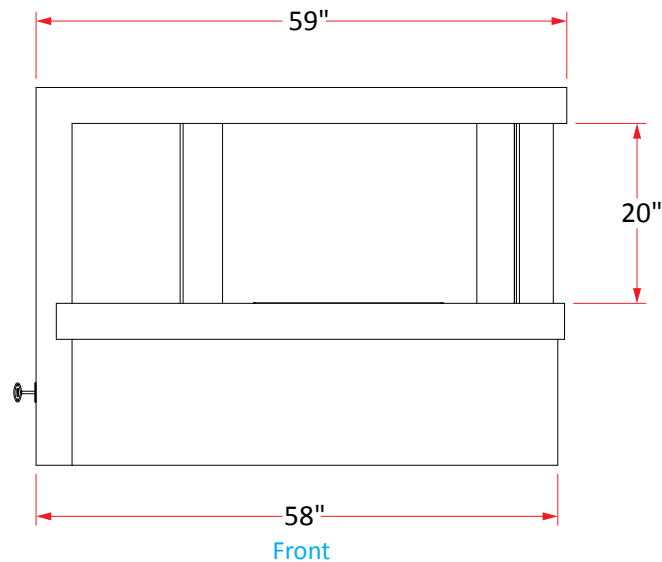
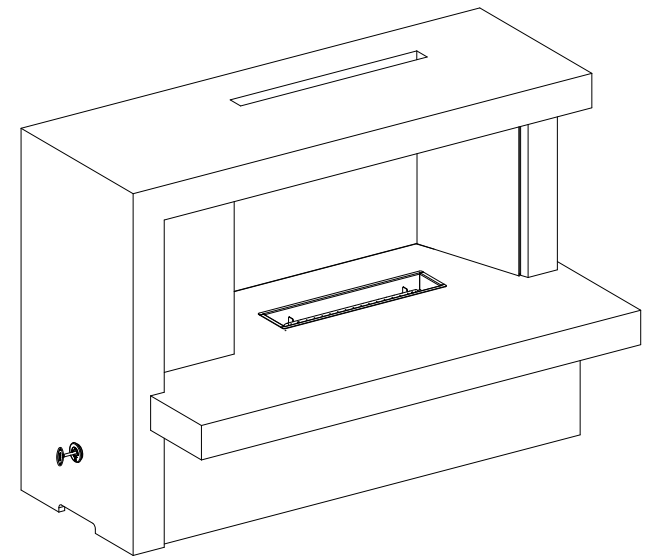
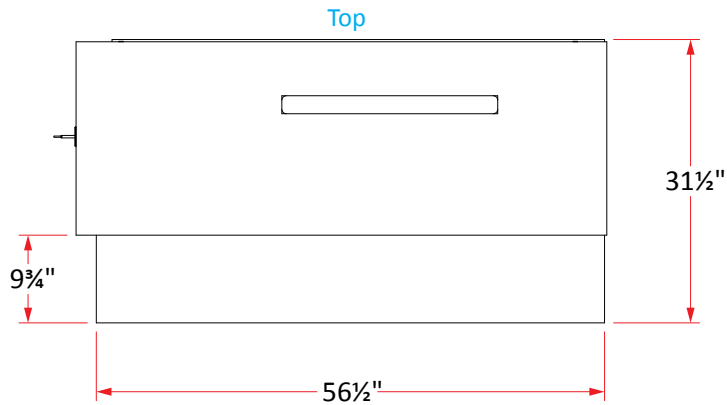

AMERICAN
FYRE DESIGNS™
outdoor Products Collection

Manhattan Fireplace

Dimensions:	59"w x 32"d x 42"h
Weight / Pieces:	750 lbs / 8 pcs
BTU's:	45,000 (NG) / 40,000 (LP)

*Manhattan Fireplace comes standard with a Natural Gas burner. For Propane, change the **next to last** digit from an "N" to a "P" in the model #. Propane model has access door for tank.*