



# OWNER'S MANUAL

## INSTALLATION INSTRUCTIONS

# AC2030T / AC3040T TOP VENT GAS WALL HEATER

### SINGLE SIDED MODEL NUMBERS:

AC2030TN (*natural gas*)

AC2030TP (*propane gas*)

### DOUBLE SIDED MODEL NUMBERS:

AC3040TN (*natural gas*)

AC3040TP (*propane gas*)

SAVE THIS MANUAL FOR FUTURE REFERENCE.

READ THIS OWNER'S MANUAL CAREFULLY BEFORE YOU  
INSTALL YOUR NEW WILLIAMS WALL FURNACE.

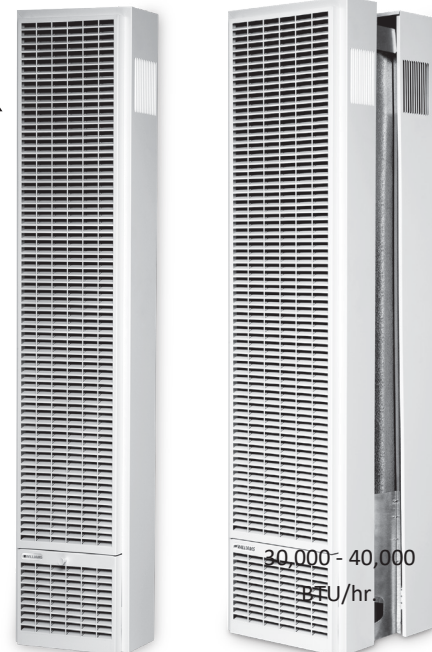

20,000 -30,000  
BTU/hr.

30,000 - 40,000  
BTU/hr.

**WARNING:** INSTALLATION IN MANUFACTURED HOMES Williams Top-Vent Furnaces are allowed in manufactured homes when the following conditions are met:

- The manufactured home is permanently sited per local codes.
- The manufactured home is manufactured after 6/15/1976 and is HUD approved with a red certification label (US only). These models are allowed only in

**WARNING:** This product can expose you to chemicals including carbon monoxide, which is known to the State of California to cause cancer, and formaldehyde, which is known to the State of California to cause cancer. For more information about these risks, go to the following website: [www.cdph.ca.gov](http://www.cdph.ca.gov)

**WARNING:** Improper installation, adjustment, alteration, service or maintenance can cause injury or property damage. Refer to this manual. For assistance or for additional information consult a qualified installer, service agency or the gas supplier.

**WARNING:** If the information in these instructions is not followed exactly, a fire or explosion may result causing property damage, personal injury or loss of life.

- Do not store or use gasoline or other flammable vapors and liquids in the vicinity of this or any other appliance.

### WHAT TO DO IF YOU SMELL GAS:

- Open all windows.
- Do not try to light any appliance.
- Do not touch any electrical switch; do not use any phone or cell phone in your building.
- Extinguish any open flame.
- Immediately call your gas supplier from a neighbor's phone. Follow the gas supplier's instructions.
- If you cannot reach the gas supplier, call the fire department.
- Installation and service must be performed by a qualified installer, service agency or the gas supplier.

250 West Laurel Street, Colton CA 92324

• [www.wfc-fc.com](http://www.wfc-fc.com) • 1-888-444-1212

# WARRANTY

The manufacturer, Williams Furnace Co., warrants this wall furnace or heater to the original purchaser under the following conditions:

## LIMITED ONE-YEAR WARRANTY

1. Any part thereof which proves to be defective in material or workmanship within one year from date of original purchase for use will be replaced at the Manufacturer's option, FOB to its factory.
2. No liability is assumed by the Manufacturer for removal or installation labor costs, nor for freight or delivery charges.

## LIMITED EXTENDED WARRANTY

1. In addition to the above limited one-year warranty on the complete unit, any combustion chamber which burns out or rusts under normal installation, use and service conditions during a period of nine years following expiration of the one-year warranty period will be exchanged for a like or functionally similar part.
2. No liability is assumed by the Manufacturer for removal or installation labor costs, nor for freight or delivery charges.

## LIMITATIONS

1. THIS LIMITED WARRANTY IS THE ONLY WARRANTY MADE BY THE MANUFACTURER, IMPLIED WARRANTIES OF MERCHANTABILITY OR FITNESS FOR ANY PARTICULAR PURPOSE ARE LIMITED TO THE SAME ONE YEAR TERM AS THE EXPRESS WARRANTY. UNDER NO CIRCUMSTANCES SHALL THE MANUFACTURER BE LIABLE FOR INCIDENTAL, CONSEQUENTIAL, SPECIAL OR CONTINGENT DAMAGES OR EXPENSES ARISING DIRECTLY OR INDIRECTLY FROM ANY DEFECT IN THE PRODUCT OR ANY COMPONENT OR FROM THE USE THEREOF. THE REMEDIES SET FORTH HEREIN ARE THE EXCLUSIVE REMEDIES AVAILABLE TO THE USER AND ARE IN LIEU OF ALL OTHER REMEDIES.

Some states do not allow limitation on how long an implied warranty lasts, and some states do not allow the exclusion or limitation of incidental or consequential damages, so the above limitations or exclusions may not apply to you.

2. This warranty does not include any charge for labor or installation.
3. This warranty does not extend to painted surfaces or to damage or defects resulting from accident, alteration, misuses or abuse or improper installation.
4. This warranty does not cover claims which do not involve defective workmanship or materials.

## DUTIES OF THE CONSUMER

1. The heating equipment must be installed by a qualified installer and operated in accordance with the installation and homeowner's instructions furnished with the equipment.
2. Any travel, diagnostic costs, service labor, and labor to repair the defective unit will be the responsibility of the owner.
3. A bill of sale, canceled check, payment record or permit should be kept to verify purchase date to establish the warranty period.
4. Have the installer enter the requested information in the space below.

## GENERAL

1. The manufacturer neither assumes nor authorizes any person to assume for it any other obligation or liability in connection with said equipment.
2. Service under this warranty should be obtained by contacting your dealer. Provide the dealer with the model number, serial number, and purchase date verification.
3. If, within a reasonable time after contacting your dealer, satisfactory service has not been received, contact: Customer Service Department, 250 West Laurel Street, Colton, CA 92324 for assistance.
4. THIS WARRANTY GIVES YOU SPECIFIC LEGAL RIGHTS AND YOU MAY ALSO HAVE OTHER RIGHTS WHICH VARY FROM STATE TO STATE.

---

# INSTALLATION RECORD

Model No. \_\_\_\_\_ Serial No. \_\_\_\_\_

Original Purchaser \_\_\_\_\_

Address \_\_\_\_\_

City and State \_\_\_\_\_ Zip \_\_\_\_\_

Dealer \_\_\_\_\_

Address \_\_\_\_\_

City and State \_\_\_\_\_ Zip \_\_\_\_\_

Installation Date \_\_\_\_\_ Name \_\_\_\_\_ Signature \_\_\_\_\_

(Dealer or authorized representative who certifies that this appliance is installed in accordance with Manufacturer's instructions and local codes.)

# CONTENTS

YOUR WILLIAMS WARRANTY	2
INSTALLATION RECORD	2
TABLE OF CONTENTS	3
SAFETY RULES	4
INTRODUCTION	5
BASIC MATERIALS NEEDED	6
BASIC TOOLS NEEDED	6
OPTIONAL ACCESSORIES	6
INSTALLING YOUR WALL FURNACE	7
LOCATING WALL FURNACE AND THERMOSTAT	7
COMBUSTION & VENTILATION AIR	8
<b>INSTALLATION</b>	<b>8</b>
RECESSED MOUNT INSTALLATION	11
SURFACE MOUNT INSTALLATION	13
VENT INSTALLATION	15
ATTACHING YOUR FURNACE	16
GAS SUPPLY AND PIPING	17
FRONT PANEL INSTALLATION	19
THERMOSTAT INSTALLATION	19
START UP PROCEDURE	20
STAY SAFE	21
OPERATING YOUR FURNACE	21
HOW TO CARE FOR YOUR FURNACE	22
INSTALLING YOUR MOTORIZED REAR OUTLET ACCESSORY	23
MOTORIZED REAR OUTLET REPLACEMENT PARTS	26
FURNACE REPLACEMENT PARTS - SINGLE SIDED	28
FURNACE REPLACEMENT PARTS - DOUBLE SIDED	30
WIRING DIAGRAM	32
SERVICE HINTS	33
TROUBLESHOOTING CHART	34

## Quick Reference Here's how to:

<b>INSTALLING YOUR FURNACE</b>	8
Recessed Mount, Surface Mount, and Vent Installation are explained starting on page 8.	
<b>OPERATING YOUR FURNACE</b>	21
Igniting your furnace for the first time.	
<b>HOW TO CARE FOR YOUR FURNACE</b>	22
Learn how to keep your new Williams Furnace operating.	

# SAFETY RULES

**⚠ WARNING:** Read these rules and the instructions carefully. Failure to follow these rules and instructions could cause a malfunction of the furnace. This could result in death, serious bodily injury and/or property damage. **INSTALLATION MUST CONFORM TO LOCAL CODES. IN THE ABSENCE OF LOCAL CODES,**

INSTALLATION MUST CONFORM TO THE NATIONAL FUEL GAS CODE, ANSI Z223.1. THE APPLIANCE, WHEN INSTALLED MUST BE ELECTRICALLY CONNECTED AND GROUNDED IN ACCORDANCE WITH LOCAL CODES OR, IN THE ABSENCE OF LOCAL CODES, WITH THE CURRENT NATIONAL ELECTRICAL CODE ANSI/NFPA NO. 70.

**IN CANADA:** Installation must conform to local codes or, in the absence of local codes, the current CAN/CGA B149 installation code. The appliance, when installed, must be grounded in accordance with local codes, with the current CSA C22.1 Canadian Electrical Code. Reference is made in this manual regarding gas type as Propane. Be advised that Propane is not available in Canada; refer to Propane.

**⚠ WARNING:** Do not use this furnace if any part has been under water. Immediately call a qualified service technician to inspect the furnace and to replace any part of the control system and any gas control which has been under water.

1. Use only manufacturer's replacement parts. Use of any other parts could cause injury or death.
2. DO NOT install the furnace where it could be isolated by closing doors to the heated space.
3. DO NOT install these furnaces in a travel trailer, recreational vehicle or mobile home.
4. MAINTAIN all clearances specified in section "Locating Wall Furnace and Thermostat" and "Vent Installation."
5. BE SURE the furnace is for type of gas being used. Check the nameplate by the gas valve in the lower cabinet. Do not change it to use other gases without the proper manufacturer's gas conversion kit.
6. For natural gas, the minimum inlet gas supply pressure for the purpose of input adjustment is 5" water column. The maximum inlet gas supply pressure is 7" water column.
7. Any safety screen, guard or parts removed for servicing this appliance must be replaced prior to operating the appliance to avoid property damage, bodily injury or death.
8. Vent the furnace directly to the outdoors, so that harmful gases will not collect inside the building. Follow the venting instructions for your type installation exactly. Use only the type and size of vent pipe and fittings specified.

9. Provide for adequate combustion and ventilation air. See page 7. The flow of this air to the furnace must not be blocked.
10. NEVER vent flue gases into another room, a fireplace or any space inside a building. This could cause property damage, bodily injury or death.
11. NEVER test for gas leaks with an open flame. Use a soap solution to check all gas connections. This will avoid the possibility of fire or explosions.
12. ALLOW furnace to cool before servicing. Always shut off electricity and gas to furnace when working on it. This will prevent any electrical shocks or burns.
13. DUE TO HIGH TEMPERATURES, locate the furnace out of traffic and away from furniture and draperies.
14. ALERT children and adults to the hazards of high surface temperatures and warn them to keep away to avoid burns or clothing ignition.
15. CAREFULLY supervise young children when they are in the same room with the furnace.
16. DO NOT place clothing or other flammable material on or near furnace.
17. INSTALLATION and REPAIR must be done by a qualified service person. The appliance should be inspected before use and at least annually by a professional service person. More frequent cleaning may be required due to excessive lint from carpeting, bedding material, etc. It is imperative that control compartments, burners and circulating air passages be kept clean.
18. BEFORE INSTALLING: To avoid electrical shock, turn off electrical circuits that pass through the wall where you are going to install the furnace.
19. BE AWARE of good safety practices by wearing personal protective equipment such as gloves and safety glasses to avoid being injured by sharp metal edges in or around the furnace while cutting or drilling holes in wood and/or sheet metal.
20. CAUTION: Label all wires prior to disconnection when servicing controls.
21. DO NOT store or use gasoline or other flammable liquids or vapors near the furnace.

**⚠ WARNING:** Do not install any of these furnaces in mobile homes, trailers or recreational vehicles.

# INTRODUCTION

The following steps are all needed for proper installation and safe operation of your furnace. If you have any doubts as to any requirements, check with local authorities. Obtain professional help where needed. All of the checks and adjustments in the Start-Up Procedures are vital to the proper and safe operation of the furnace. Please read the instructions before you install and use your furnace. This will help you obtain the full value from this furnace. It could also help you avoid needless service costs if the answer to the problem is found within this instruction manual.

Always consult your local heating or plumbing inspector, building department or gas utility company regarding regulations codes or ordinances which apply to the installation of a vented wall furnace.

Check the furnace nameplate, located in the burner compartment, to make sure your furnace is equipped to operate on the type of gas available (either natural or

Propane). DO NOT convert the furnace from natural gas to

Propane or from Propane to natural gas without the proper manufacturer's gas conversion kit.

Combustion air is drawn in from the room where the furnace is located and is vented out of the top of the furnace vertically through vent piping in the stud space to a roof vent top. Vent material is not supplied with the furnace.

This furnace is equipped with a vent safety shutoff system designed to protect against improper venting of combustion products. Operation of this wall furnace when not connected to a properly installed and maintained venting system or tampering with the vent safety shutoff system can result in carbon monoxide (CO) poisoning and possible death.

The efficiency rating of this furnace is a product thermal efficiency rating determined under continuous operating conditions and was determined independent of any installed system. The furnace will not function unless the venting system is installed



## **WARNING: CARBON MONOXIDE POISONING HAZARD**

**Failure to follow the steps outlined below for each appliance connected to the venting system being placed into operation could result in carbon monoxide poisoning or death.**

*The following steps shall be followed for each appliance connected to the venting system being placed into operation, while all other appliances connected to the venting system are not in operation:*

- 1) Seal any unused openings in the venting system.
- 2) Inspect the venting system for proper size and horizontal pitch, as required in the National Fuel Gas Code, ANSI Z223.1/NFPA 54 or the Natural Gas and Propane Installation Code, CSA B149.1 and these instructions. Determine that there is no blockage or restriction, leakage, corrosion and other deficiencies which could cause an unsafe condition.
- 3) As far as practical, close all building doors and windows and all doors between the space in which the appliance(s) connected to the venting system are located and other spaces of the building.
- 4) Close fireplace dampers.
- 5) Turn on clothes dryers and any appliance not connected to the venting system. Turn on any exhaust fans, such as range hoods and bathroom exhausts, so they are operating at maximum speed. Do not operate a summer exhaust fan.
- 6) Follow the lighting instructions. Place the appliance being inspected into operation. Adjust the thermostat so appliance is operating continuously.
- 7) Test for spillage from draft hood equipped appliances at the draft hood relief opening after 5 minutes of main burner operation. Use the flame of a match or candle.
- 8) If improper venting is observed during any of the above tests, the venting system must be corrected in accordance with the National Fuel Gas Code, ANSI Z223.1/NFPA 54 and/or Natural Gas and Propane Installation Code, CSAB149.1.
- 9) After it has been determined that each appliance connected to the venting system properly vents when tested as outlined above, return doors, windows, exhaust fans, fireplace dampers and any other gas-fired burning appliance to their previous conditions of use.

# INTRODUCTION

## Basic Materials Needed

- Pipe and fittings to make gas connections to the furnace.
- Vertical venting materials. **See page 14, Figure 8.**
- Pipe Joint Compound resistant to Propane.
- Electrical wiring supplies as needed. Minimum wire size is #14 gauge copper.

## Basic Tools Needed

- Hand drill or properly grounded electric drill
- Expansion bit 1/2" to 1-5/8" or 1/2" and 1-1/2" blade bits
- 1/8" and 3/16" drill bit (metal)
- 6 ft. folding rule or tape measure
- Screwdriver (medium blade)
- Screwdriver (Phillips and Flat Head)
- Pliers (wire cutting)
- Hammer
- Stud Locator or small finishing nails
- Tin Snips
- 8" adjustable wrench
- 12" adjustable wrench
- 7/8" wrench
- 3/4" wrench
- 1" wrench
- Gloves and safety glasses

## Helpful Installation Information

The following booklets will help you in making the installation:

ANSI/NFPA 70, or current edition "National Electrical Code". In Canada: CSA C22.1 Canadian Electrical Code.

American National Standard Z223.1 or current edition of the "National Fuel Gas Code."

Obtain from the American National Standard Institute, Inc., 1430 Broadway, New York, NY 10018. In Canada, CAN/CGA B149.

## Optional Accessories

### **Free Standing Accessory 4901 (AC2030T Only)**

This accessory allows the furnace to be mounted on the surface of a wall.

### **Face Panel 4915 - Front Panel**

### **Rear Outlet Registers 6920 (AC2030T Only)**

When recessed into a standard 2 x 4 inch interior stud partition, this accessory directs some of the heated air into the room opposite the one in which the furnace is installed.

**Oval B/W Vent Kit 9929 / 9930 CANADA** - This U.L. Listed B/W vent kit contains four feet of oval, double-walled vent pipe, plate spacers and base or hold-down plate that starts the venting from the top of furnace. See Vent Installation on page 14 for additional items you will need.

## **GAS CONVERSION KITS**

### **SINGLE SIDE**

**M117854** Conversion Kit Propane to Natural Gas

**M117853** Conversion Kit Natural Gas to Propane

### **DOUBLE SIDE**

**M117881** Conversion Kit Propane to Natural Gas

**M117880** Conversion Kit Natural Gas to Propane

# INSTALLING YOUR FURNACE

The following steps are needed for proper installation and safe operation of your furnace. If you have any doubts as to any requirements, obtain professional help. Remember to ALWAYS consult your local heating or plumbing inspector, building department or gas utility company regarding regulations, codes, or ordinances which apply to the installation and location of a vented wall furnace.

## IMPORTANT

For satisfactory and trouble-free operation, be sure to:

1. Locate the furnace properly within the space to be heated.
2. Install the furnace in accordance with local codes or ordinances and instructions provided. In the absence of local codes or ordinances, install the furnace to conform with the current edition of the National Fuel Gas Code, NFPA 54, ANSI Z223.1/Canadian Installation Code, CAN/CGA B149.
3. Maintain minimum clearances: Floor 2½-inches, ceiling 16-inches, side wall 1-inch.
4. Provide enough combustion and ventilation air.

## LOCATING WALL FURNACE & THERMOSTAT

The furnace is installed between 2x4 inch wall studs spaced on 16-inch centers or a stud space that can be framed in to 16-inches. Consider the following points before attempting to install the furnace:

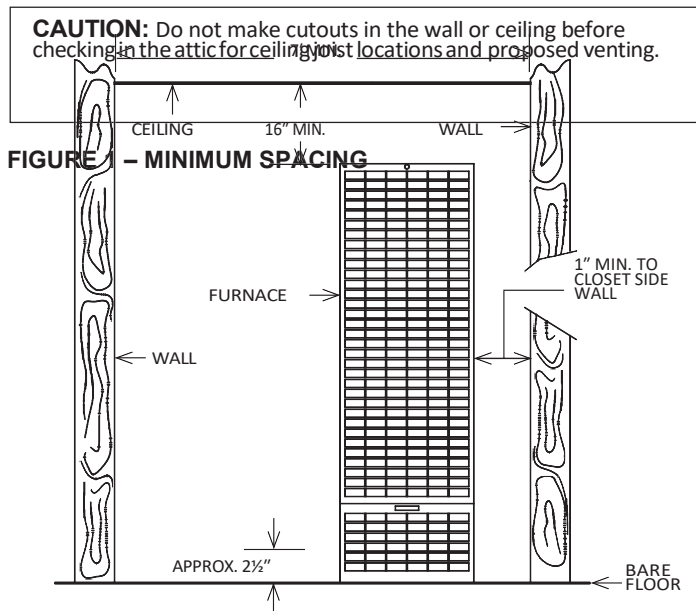

1. Locate the furnace near the center of the space to be heated for good air circulation. Do not put it behind a door or draperies. Do not install the furnace where it could be isolated by closing doors to the heated space. Do not locate the furnace where a door could swing over the front panel or where circulation could be retarded by furniture or cabinets.
2. Check the minimum spacing needs as shown in **Figure 1**.
3. The top of the furnace must be at least 16-inches from the ceiling.
4. When the furnace is properly installed with legs resting on the floor plate, it sets the dimension from the face panel to the bare floor. (Approximately 2½-inches depending on the thickness of floor plate).
5. A protective barrier (metal or wood), cut to match the width and depth of the furnace, should be used to cover over any floor coverings such as carpet or vinyl under the furnace. At no time should the dimension from the bottom of the face panel to the protective barrier be less than 1½-inches.
6. In the space to be heated, the side of the furnace may be as close as 1-inch to an intersecting wall. The recessed portion may have 0-inches clearance to combustible material.
7. Select a location that will provide adequate accessibility clearance for servicing and proper operation.
8. After picking a location, inspect the wall, floor, attic and roof areas. Make sure there are no pipes, wiring, bracing, etc., that will interfere with furnace or vent installation. If required, move them or pick a new installation location.
9. Be sure that gas piping and electrical wiring can be brought to the location. Electrical wiring is required for optional blower accessory.
10. If installing the thermostat on the wall, locate the thermostat approximately 5-feet above the floor on an inside wall where it will sense the average room temperature.

The thermostat should be sensing average room temperature; avoid the following:

### HOT SPOTS:

Concealed pipes or ducts  
Fireplaces  
Registers TV sets  
Radios  
Lamps  
Direct sunlight Kitchen

### COLD SPOTS:

Concealed pipes or ducts Stairwell - drafts  
Door - drafts  
Unheated rooms on other side of wall

### DEAD SPOTS:

Behind doors Corners and alcoves

# INSTALLING YOUR FURNACE

After picking a location that meets the requirements, check the walls, attic and roof to make sure there are no obstructions such as pipes, electrical wiring, etc., which could interfere with the installation of the furnace or vent pipe. If required, move them or pick a new location.

**⚠ WARNING:** Danger of property damage, bodily injury or loss of life. Do not install the furnace in any area where oxygen is in use.

## Combustion & Ventilation Air

When an existing category I heater is removed or replaced, the original venting system may no longer be sized to properly vent the attached appliances.

**⚠ WARNING:**  
**CARBON MONOXIDE POISONING HAZARD**

Failure to follow the steps outlined below for each appliance connected to the venting system being placed into operation could result in carbon monoxide poisoning or death.

The following steps shall be followed for each appliance connected to the venting system being placed into operation, while all other appliances connected to the venting system are not in operation:

1. Seal any unused openings in the venting system.
2. Inspect the venting system for proper size and horizontal pitch, as required in the National Fuel Gas Code, ANSI Z223.1/NFPA 54 or the Natural Gas and Propane Installation Code, CSA 8149.1 and these instructions. Determine that there is no blockage or restriction, leakage, corrosion and other deficiencies which could cause an unsafe condition.
3. As far as practical, close all building doors and windows and all doors between the space in which the appliance(s) connected to the venting system are located and other spaces of the building.
4. Close fireplace dampers.
5. Turn on clothes dryers and any appliance not connected to the venting system. Turn on any exhaust fans, such as range hoods and bathroom exhausts, so they are operating at maximum speed. Do not operate a summer exhaust fan.
6. Follow the lighting instructions. Place the appliance being inspected into operation. Adjust the thermostat so appliance is operating continuously.
7. Test for spillage from draft hood equipped appliances at the draft hood relief opening after 5 minutes of main burner operation. Use the flame of a match or candle.
8. If improper venting is observed during any of the above tests, the venting system must be corrected in accordance with the National Fuel Gas Code, ANSI Z223.1/ NFPA 54 and/or Natural Gas and Propane Installation Code, CSA 8149.1

9. After it has been determined that each appliance connected to the venting system properly vents when tested as outlined above, return doors, windows, exhaust fans, fireplace dampers and any other gashed burning appliance to their previous conditions of use.

**⚠ WARNING:** Danger of property damage, bodily injury or loss of life. The furnace and any other fuel-burning appliances must be provided with enough fresh air for proper combustion and ventilation of flue gases.

Most homes will require that outside air be supplied into the heated area. The high cost of energy for home heating has brought about new materials and methods used to construct or remodel most current homes. The improved construction and additional insulation has reduced the heat loss and made these homes much tighter around windows and doors so that infiltrated air is minimal. This creates a problem to supply combustion and ventilation air for gas-fired or other fuel burning appliances. Any use of appliances that pull air out of the house (clothes dryers, exhaust fans, fireplaces, etc.) increases this problem and appliances could be starving for air.

The combination of a tight energy efficient home with the use of exhaust fans, fireplaces, clothes dryers, and gas appliances result in more and more air being drawn from the house until fresh air may be sucked back into the house down a furnace flue or fireplace chimney. Carbon monoxide can be the result. Carbon monoxide (CO) is a colorless, odorless gas produced when fuel is not burned completely or when the flame does not receive sufficient oxygen. Automobiles, charcoal, wood fires and improperly vented or air-starved coal, oil and gas furnaces or other appliances can produce carbon monoxide.

Do not install furnace in the same room or near a wood solid fuel burning fireplace.

### BE AWARE OF THESE AIR-STARVATION SIGNALS:

1. Headaches, nausea, dizziness.
2. Excessive humidity shown by heavily frosted windows or a moist "clammy" sensation.
3. Fireplace smoke fills the room or will not draw.
4. Furnace flue backup.

### AIR REQUIREMENTS

The requirements for providing air for combustion and ventilation are listed in the National Fuel Gas Code NFPA 54/ANSI Z223.1 (in Canada: CAN/CGA B149). Most homes will require that outside air be supplied to the heated area by means of ventilation grilles or ducts connecting directly to the outside or spaces open to the outdoors such as attic or crawl space. The only exception is when the heated area meets the requirements and definitions for an unconfined space with adequate air infiltration.

All air openings and connecting ducts must comply with the following: (*continued on next page*)



If the furnace is installed in an area with another gas appliance(s), the total input rating of all appliances must be considered when determining the free area requirements for combustion and ventilation air openings.

Ducts must have the same cross-sectional area as the free area of the openings to which they connect. The minimum dimension of rectangular air ducts must not be less than 3-inches in length or height.

**WARNING:** Danger of property damage, bodily injury or loss of life. Even when a house meets requirements for unconfined space with adequate air infiltration, it is recommended that a fresh air intake be installed to lessen the possible dangers from any future changes on the home.

**LOUVERS / GRILLES AND SCREENS COVERING FREE AREA OPENINGS**

If a screen is used to cover the opening(s), it must not be smaller than 1/4-inch mesh. Use the free area of a louver or grille to determine the size opening required to provide the free area specified. If the free area is not known, assume a 20% free area for wood and a 60% free area for metal louvers or grilles.

**INFILTRATION AIR**

If your furnace is in an open area (unconfined space), the air that leaks through the cracks around doors and windows may be enough for combustion and ventilation air. The doors should not fit tightly. The cracks around windows should not be caulked or weather stripped.

Spillage means air starvation. A fresh air duct or air intake opening must be installed to provide air directly to the furnace or other gas appliances.

If spillage exists or when the furnace is in a building of tight construction where the windows and doors are weather stripped, air for combustion and ventilation must be obtained from outdoors or space open to the outdoors.

To determine if infiltration air is adequate, perform the following checks:

1. Close all doors and windows. If you have a fireplace, start a fire and wait until flames are burning vigorously.
2. Turn on all exhausting devices, i.e., kitchen and bathroom exhaust fans; water heaters (gas and electric).
3. Turn on all vented gas appliances, i.e., heating equipment (includes any room heaters), water heaters.
4. Wait ten (10) minutes for drafts to settle.
5. Check for draft hood spillage at each appliance. Hold a lit match two-inches from the draft opening. **(Figure 2).**

**A. No Spillage**

If the match flame pulls toward draft hood, this indicates sufficient infiltration air. Return exhausting devices and appliances to the condition you found them.

**B. Draft Hood Spills** If there is spillage at a draft hood (match goes out or flame wavers away from draft hood), check for plugged flue connectors and chimneys. Repair blockage and test again.

**FIGURE 2 – DRAFT HOOD SPILLAGE**

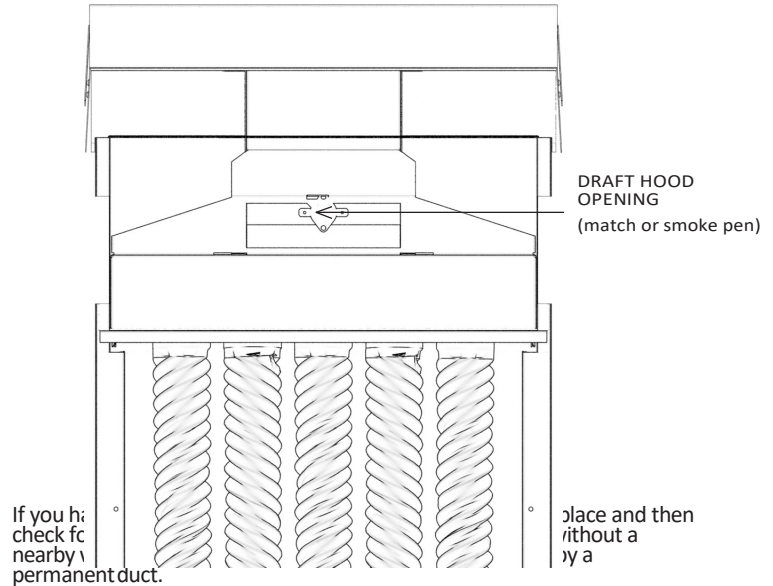

If you have kitchen and bathroom exhaust fans, turn them off and check for spillage. If spillage stops, do not use exhaust fans (circuit breakers for fans should be turned off) until you can supply fresh air by a permanent duct.

Provide opening(s) having a total free area of one-square-inch per 4,000 BTU/hr. of the total combined input ratings for all appliances in the area. The required free area is shown in **Figure 3**. This fresh air opening or duct must terminate at a point not more than one-foot above the floor. It must have at least one-square inch of free area for each 4,000 BTU/hr. of input of all appliances in area.

**FIGURE 3 – FREE AREA**

Free Area in Square Inches.  
Each opening is based on one square inch per 4,000 BTU/hr

BTU/hr input	Square inches of opening	Required number of holes sill or header plates		
		1-1/2"	2"	3"
30,000	7.5	7	4	2
35,000	8.75	8	5	2
40,000	10.00	9	5	3
45,000	11.25	10	6	3
50,000	12.50	11	8	3
60,000	15.00	13	8	4

# INSTALLING YOUR FURNACE

## HOLE PLACEMENT - EXAMPLE

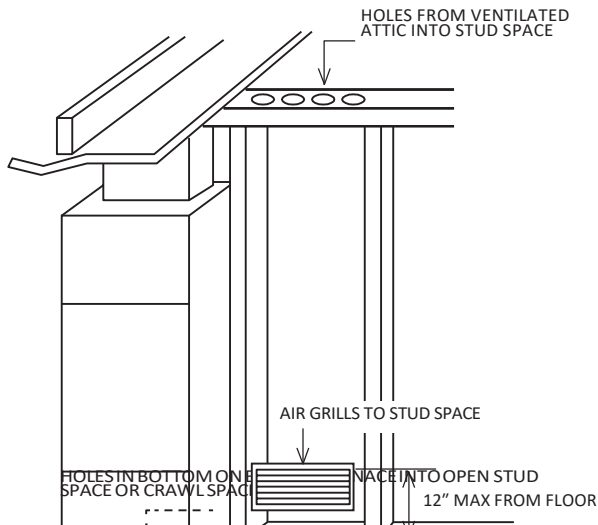

## FURNACE LOCATED IN UNCONFINED SPACE

An unconfined space must have a volume of a minimum 50 cubic feet per 1,000 BTU/hr. of the total combined input of all appliances in the area. Adjoining rooms may be included only if there are no doors between the rooms or if special provisions are made such as ventilation grilles installed between connecting rooms. **Figure 4** outlines the minimum area in square feet, based on 8-foot ceiling heights for various BTU/hr. input ratings.

**FIGURE 4 - MINIMUM AREA**

4,000 BTU/hr. per square inch opening		Max. BTU/hr input	*Uncontained space min. area in sq. ft. 8' ceiling height
Round duct dia.	Rectangular square duct size		
4"	3" x 3"	30,000	145
4"	3" x 3"	35,000	219
4"	3" x 4"	40,000	240
4"	3" x 4"	45,000	281
4"	3" x 5"	50,000	312
4 ½"	3" x 5"	60,000	375

\* Can be two or more rooms separated by ventilation gas fire.

## EXAMPLES OF GRILL PLACEMENT

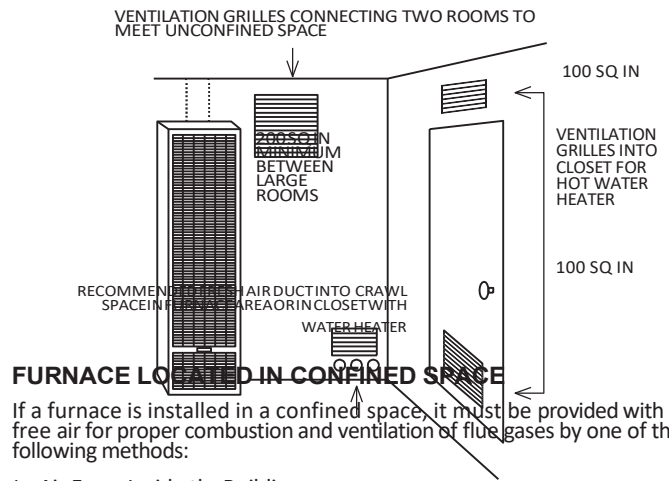

## FURNACE LOCATED IN CONFINED SPACE

If a furnace is installed in a confined space, it must be provided with free air for proper combustion and ventilation of flue gases by one of the following methods:

### A. Air From Inside the Building

If the confined space adjoins an unconfined space, provide two permanent openings. One within 12-inches of the top and another within 12-inches of the bottom of the room directly connected to the unconfined space. Each opening must have a free area of at least 100-square inches or 1-square inch per 1,000 BTU/hr. of input for all appliances combined.

**⚠ WARNING:** Danger of property damage, bodily injury or death. The adjoining unconfined space must have adequate air infiltration.

### B. Air From Outdoors

If confined space does not adjoin an unconfined space, then air must be provided from outdoors or spaces open to the outdoors such as an attic or crawl spaces.

Openings for inlet or outlet air should NOT be made into an attic area if the attic is equipped with a thermostat controlled power vent.

Provide two permanent openings, one within 12-inches of the top and bottom of the room connecting directly to, or by using ducts, with the outdoors or areas open to fresh air.

If the opening connects directly to, or with vertical ducts, the free area of each opening must be at least 1-square inch per 4,000 BTU/hr. of the combined input of all appliances in the area.

If horizontal ducts are used, the free area of each opening must be at least 1-square inch per 2,000 BTU/hr. of the combined input of all appliances in the area.

**WARNING:** Danger of illness, bodily injury or death. Draft spillage, with unobstructed vents, indicates that additional air must be brought into the structure from the outside. Keep a window open (minimum 2-inches near the appliance until a permanent air duct is installed).

### EXAMPLES OF AIR INLETS AND OUTLETS

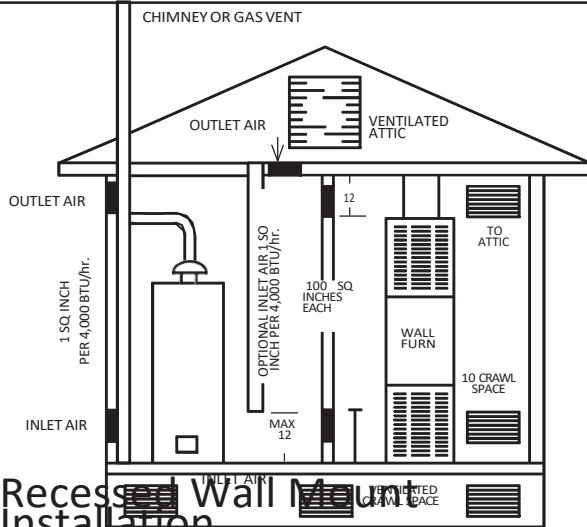

### Recessed Wall Mount Installation

The maximum recess depth from rear of furnace forward is 4½-inches.

#### FIND THE STUDS AND CEILING JOINTS

Use a stud locator or small finishing nails. Repeatedly drive and remove a nail into the wall in the area of the stud until it is located. Then find the inside edge of the stud. Leave the nail at this location.

The other stud should be about 14½-inches from the one found. Drive finishing nails on the inside of this stud. Draw wall cutout to required size as shown in Figure 5. If wall studs are not on 16-inch centers. See "CLOSE OFF STUD SPACE." (Figure 6).

#### CUT WALL OPENING

Cut wall opening 14⅝-inches wide and 66⅝-inches high measured from the top of the floor plate. (Figure 5). All corners must be square.

#### INSTALLATION OF REAR OUTLET REGISTER

The optional rear outlet register may be installed when the furnace is recessed into the wall. In new construction, install the rear outlet plaster ground at the same time you install the header plate. For existing construction, make the necessary cutout and install the plaster ground

before you install the furnace. See instructions packed with accessory and Figure 5.

Do not allow wall finish material to project into the furnace recess.

Do not install rear outlet register where grille may be blocked by a door, curtains or any other obstruction.

#### GAS SUPPLY OPENING

A hole must be drilled for the gas line. Decide whether the gas line will come through the floor or wall. Drill a 1½-inch hole through the floor or wall as needed. (Figure 5).

**CAUTION:** Be careful not to damage any furnace components while making any alternate hole.

FIGURE 5- RECESSED WALL MOUNT INSTALLATION

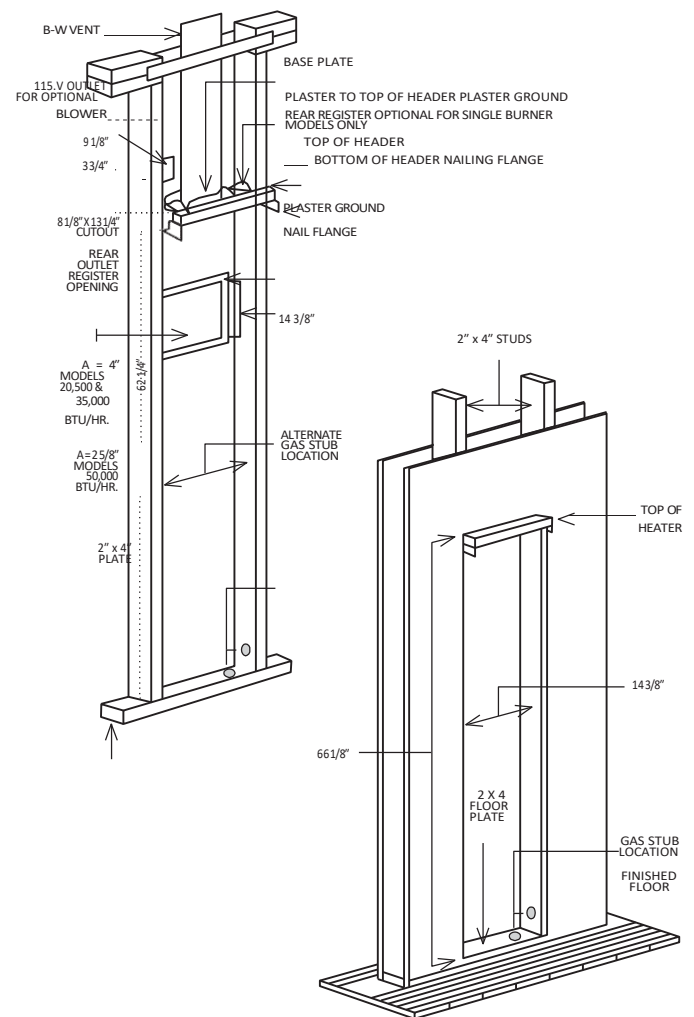

# INSTALLING YOUR FURNACE

## CLOSE OFF STUD SPACE (IF REQUIRED)

If studs are not on 16-inch centers, cut the hole for the furnace next to an existing stud and frame in the other side using a 2x4 and spacer blocks as required. **(Figure 6)**.

**FIGURE 6 – CLOSE OFF STUD SPACE**

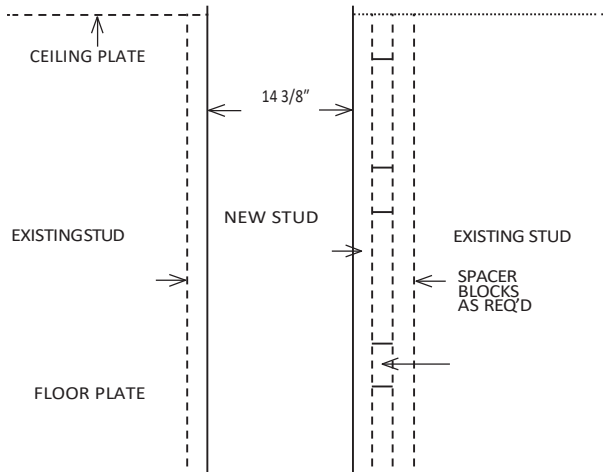

## CEILING PLATE OPENING

Cut away the ceiling plate between the studs where the furnace is to be installed. Work from the top in the attic. If there is no access to the top, remove the wall covering between the two wall studs all the way to the ceiling. Work through this opening. Cut out the entire plate so the plate edges will be even with the inner face of the 2 x 4 studs. **(Figure 7)**.

## INSTALL VENT BASE PLATE (HOLD-DOWN PLATE)

Position base plate on top of header plate and fasten with screws. **Note: Hold down plate is not included.**

## HEADER PLATE (VENT SUPPORT)

Measure upward 62 1/4 inches from the top of the floor plate. Place a mark on each stud at this distance. **(Figure 5)**. Place the header plate between the studs with the lower edges even with marks on the studs. Make sure header plate is level.

Locate rear edge of nailing tabs at back of the header. Nail header plate to the 2 x 4 studs which will center the vent collar in the wall. **(Figure 5)**.

## INSTALL CEILING PLATE SPACER

Nail the ceiling plate spacers either across or in between the cut out section of ceiling plate. If nailed between, ends must be bent at 90 degrees. They must be fastened along each long edge of the ceiling plate hole to hold the oval vent pipe in the center of the hole. Ceiling plate spacers preserve structural strength and position oval vent pipe in the center of the cut out opening. **Ceiling plate spacers are not included. (Figure 7).**

**FIGURE 7 – CEILING PLATE OPENING**

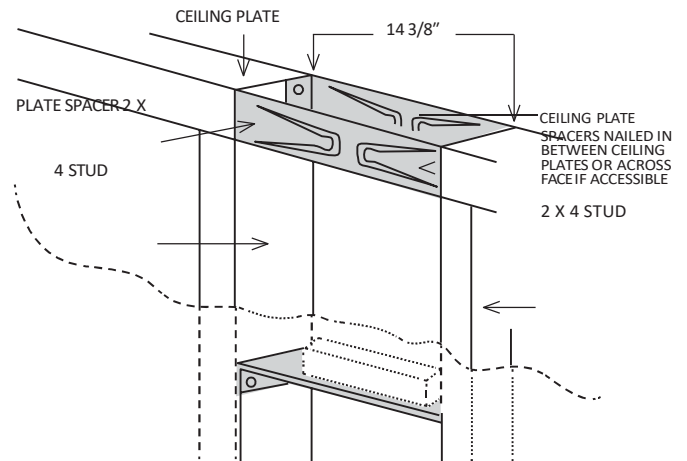

## Surface Mount Installation

The use of the optional Free Standing Accessory No. 4901 allows single-sided furnaces to be surface mounted instead of recessed into a wall. This is ideal for remodeling existing masonry wall construction or when studding is substandard. This kit drastically cuts installation time and eliminates the expense of cutting into the walls and ceiling plates. Be sure this accessory is of the type and design required for the use with your furnace.

**NOTE:** After picking a location that meets the requirements, check the wall, attic, and roof to make sure there are no obstructions such as pipes, electrical wiring, etc., which could interfere with the installation of the furnace or vent pipe. If required, move them or pick a new location.

### FIND THE WALL STUDS OR CEILING JOISTS

Find two studs or joists at the spot where the furnace is to be located. Use a stud locator or small finishing nails. Repeatedly drive and remove a nail into the wall or ceiling in the area of the stud or joist until you find it. Then find the its side and leave the nail there. Drive another nail just on the other side other the same stud or joist.

The inside of the next stud or joist should be about 14½ inches from the first one found. Drive a nail on the inside of this stud or joist.

Using the nails as a guide, draw two lines down the side of the wall from the ceiling to locate the furnace and ceiling hole cutout for venting.

### FREE STANDING ACCESSORY ASSEMBLY & INSTALLATION

1. Attach the base plate panel as shown in **Figure A** to the bottom of the side rails with four (4) # 6, ¾" screws.
2. Attach the header plate, (included with the furnace), to the side rails using four (4) #8, ¾" screws. Flanges of the header plate go against the wall. (**Figure A**).
3. Install extension side rails as shown in **Figure A**, by telescoping them inside the lower side rails. Adjust the extension side rails by sliding them up or down to ceiling height. Maximum: 8 feet 9 inches, Minimum: 7 feet 9 inches.
4. If the wall has a baseboard, cut the baseboard out to fit against the side rails. Stand the side rails against the wall and fasten them to the wall securely with screws or bolts in the holes provided. Use a level to assure the enclosure is plumb. **Screws and bolts for wall fastening are not included.**
5. After positioning the enclosure, cut a 3½ X 14 inch hole in the ceiling, centered between the studs or joists as shown in **Figure B**.
6. Cut ¼ inch off each end of the ceiling spacer plate. Place the ceiling spacer plate to the back of the wall and centered in the enclosure as shown in **Figure C**.
7. Install Type B/W vent though the roof and studs or joists in accordance with the installation instructions packed with the furnace and local codes. **See Vent**

### Installation, page 14.

8. Set the furnace body into position. (**Figure 9**), page 15. The furnace legs will rest on the bottom of the base plate panel. Utilizing the holes provided in the furnace legs, secure the furnace to the brackets attached to the bottom panel with two (2) #10, ¾" screws.
9. Install the vent enclosure panel, fastening it to the side rails with six (6) #6, ¾" screws. Trim the bottom of the panel to fit the header plate.
10. Install gas inlet through the back wall or one of the two holes provided in the bottom base plate panel. (**Figure D**.) Connect gas line to furnace. **See Gas supply and Piping, page 17.**
11. Install furnace face panel. **See Front Panel Installation, page 18.** NOTE: The panel recesses ¼-inch between the vertical edges of the enclosure.

**FIGURE A**

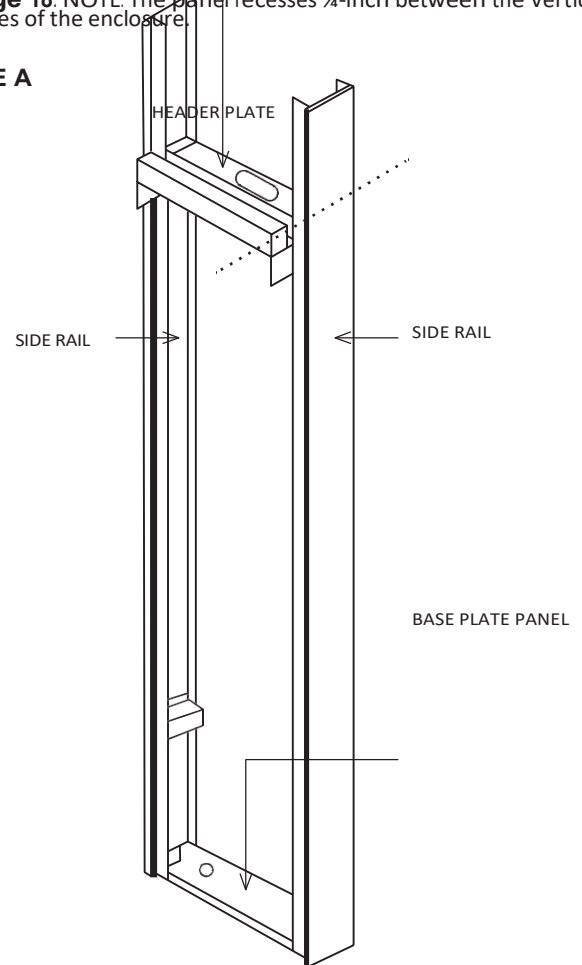

# INSTALLING YOUR FURNACE

FIGURE B

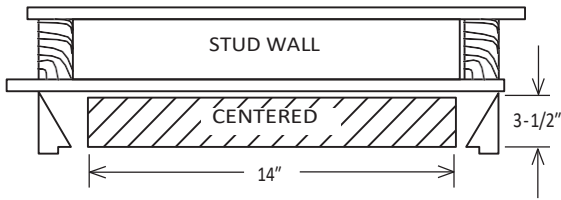

FIGURE C

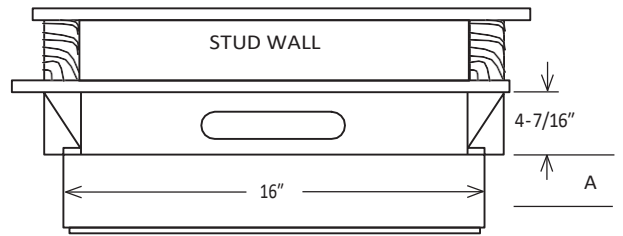
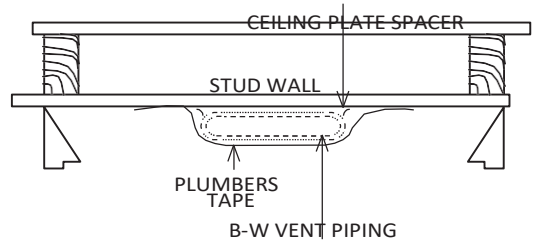
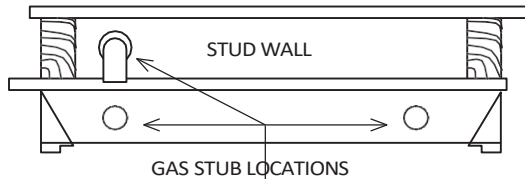
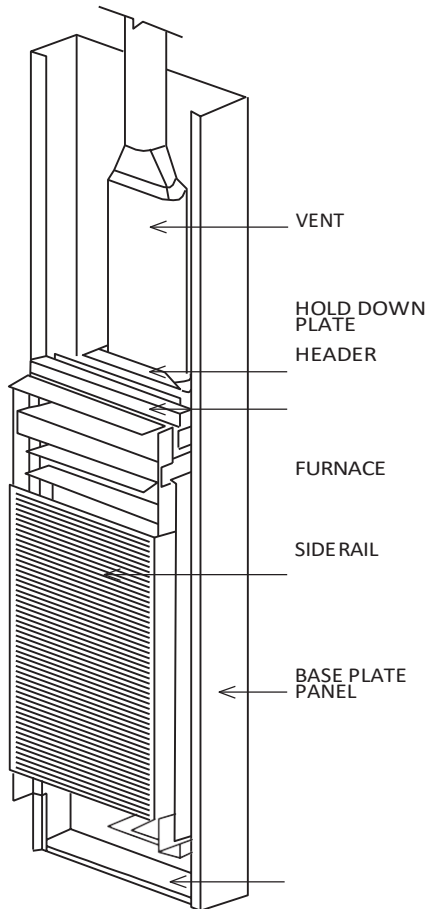

FIGURE D



VENT INSTALLED



FRONT PANEL INSTALLED

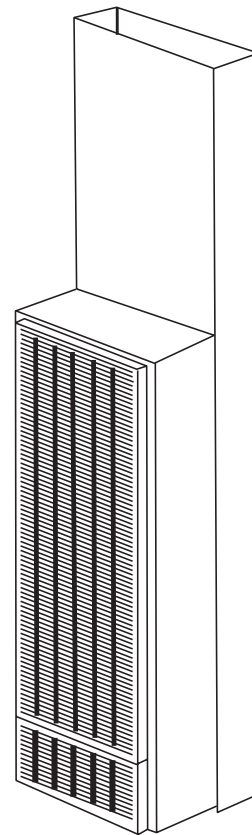

## Vent Installation

The vent installation must comply with all local codes and ordinances. If in doubt, consult your local codes or inspector.

The furnace vent must be directed to the outdoors so that harmful combustion gases will not collect inside the building.

This furnace must not be connected to a chimney flue serving a separate solid-fuel burning appliance.

This product is design certified to ANSI Z21.86. It must be installed with a U.L. tested and listed type "B" approved vent and type "B/W" approved vent (**Figure 8**). Older style terra-cotta, transite pipe, clay, concrete or masonry type vent pipe cannot be used with this appliance. These types of vent pipe will not heat fast enough to establish a draft, which will result in improper venting of combustion products.

Consequently, this could cause the vent safety control system to shut down the furnace.

The area above header within the stud space **MUST** be kept clear of any attic insulation to allow the free circulation of air around the oval vent piping. In some areas the building code requires the use of an attic shield.

The B/W vent must extend through the ceiling and roof terminating at least 12-feet above the finished floor on which the furnace rests.

### INSTALL FURNACE VENT

Attach a 4-foot length of oval, double-wall vent pipe through the plate spacers to the hold-down plate. Push the vent pipe into the hold-down plate until it is completely seated. The hold-down cleat will engage the groove in the vent pipe.

### COMPLETE THE VENTING

Type B/W gas vent shall extend from the header plate of the furnace to a point above the highest ceiling plate within the stud space through which the vent passes, without any offsets or crossovers. The first vent pipe offset, (if required), may not be any closer than 2-feet from the header and needs to extend past the ceiling plate. After a type B/W gas vent passes through the highest ceiling plate within a stud space above the furnace to which it serves, the vent system may be completed with a Type B gas vent, from the **SAME** manufacturer (do not mix brands of pipe). Offsets cannot be greater than 45 degrees from vertical. Refer to The Uniform Mechanical Code.

Install the oval-to-round adapter. Complete the piping extending it through the roof. Use a 4-inch round, double-wall (Type B) vent pipe, roof flashing, storm collar and vent cap as shown. The vent cap must be at least 2-feet higher than any point that is within 10-feet of the vent cap. There must be at least a 1-inch clearance between the vent pipe and any combustible material.

**FIGURE 8 – TYPICAL VENT INSTALLATION**

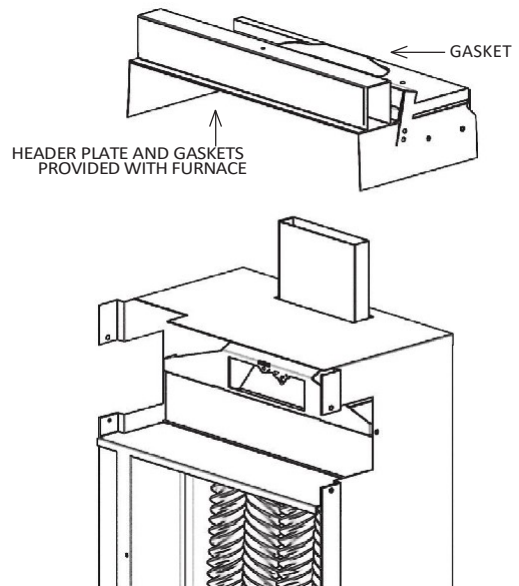
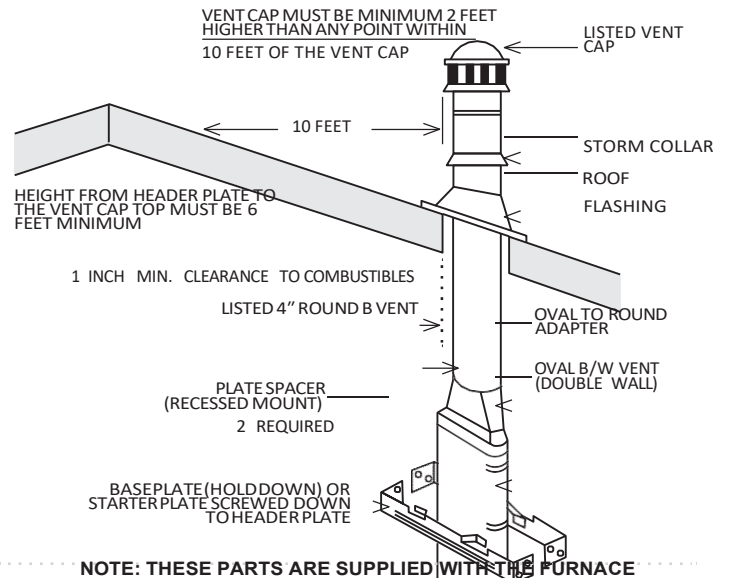

**CAUTION:** To avoid damage to wiring, be sure to route the wires away from the path of the furnace vent.

# INSTALLING YOUR FURNACE

## Attaching Your Furnace

Clear the wall recess of all debris, remove any wood or plaster. Stand the furnace in front of recess, holding the furnace body at an angle. Insert flue collar into the opening in the header plate and raise furnace carefully (Figure 9). Swing bottom of furnace into wall recess with front edges of legs flush with 2x4 floor plate. In the holes provided, nail through the legs into studs or floor plate (Figure 10).

Do not damage gasket glued to underside of header plate when placing furnace in wall. Avoid nailing the legs so tightly that it disturbs the inner furnace casing. Do not try to force the furnace into a smaller-than-specified recess.

If an existing gas line is preventing the installation of a Williams Monterey unit, a cut-out may be made using tin snips on one of the legs to clear this existing gas line. This cut-out will be on one side of the unit on the rear side of the leg and only if necessary.

**FIGURE 9 – INSERT FURNACE**

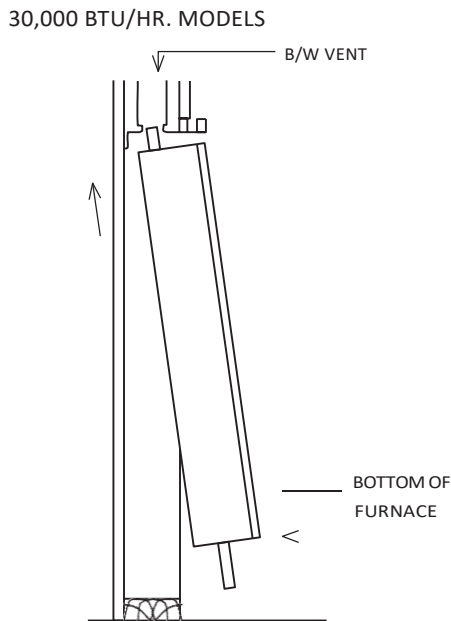

**FIGURE 10 – NAIL PLACEMENT**

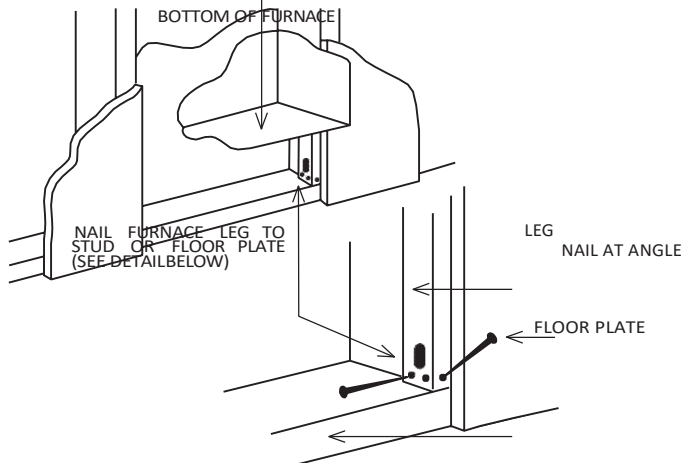

### REAR OUTLET KIT INSTALLATION (OPTIONAL)

If a Rear Outlet Register Accessory is used, the following procedure must be completed before placing furnace body into wall recess. (Figure 11). Attach speed nuts to outer shield and remove knockout plates from both the outer and inner shields as follows:

1. Punch in the lower corners with a screwdriver blade.
2. Break the knockout side and bottom connecting tabs by holding a screwdriver blade sideways against the tab and striking the head of the screwdriver lightly with a hammer.
3. Swing the plate outward; bend it back and forth to break the top tabs. Use caution when handling sharp metal edges.

**CAUTION:** Do not install rear outlet kit where grille may be blocked by a door, curtains, or any other obstruction.

**WARNING:** Never shear or cut the furnace legs.

**FIGURE 11 – REMOVE KNOCKOUT PLATES**

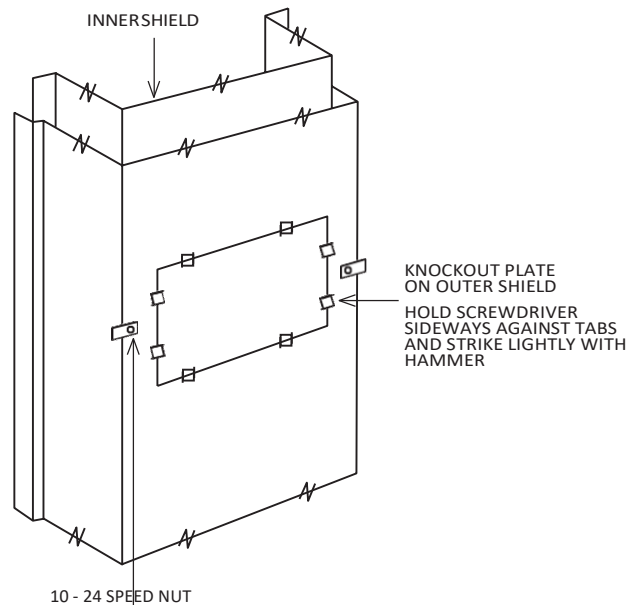



**Attaching Your Furnace** *continued* After furnace is in position, install rear outlet register as shown in **Figure 12**. Have damper in open position when inserting the assembly. Secure the rear outlet register to speed nuts with the machine screws furnished.

**FIGURE 12 – MOUNTING REAR OUTLET REGISTER**

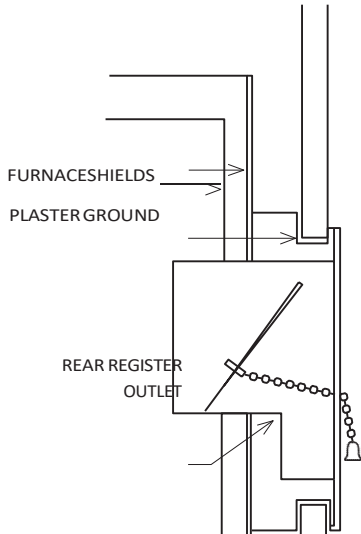

## Gas Supply and Piping

The gas control valve, in the furnace, is shipped with a seal over the gas inlet tapping. Do not remove the seal until ready to connect the piping.

**WARNING:** Danger of property damage, bodily injury or death. Make sure the furnace is equipped to operate on the type of gas available. Models designed as natural gas are to be used with natural gas only. Models designed for use with liquefied petroleum propane gas have orifices sized for commercially pure propane gas. They cannot be used with butane or a mixture of butane and propane.

### GAS SUPPLY

For natural gas, the minimum inlet gas supply pressure for the purpose of input adjustment is 5-inches water column. The maximum inlet gas supply pressure is 7-inches water column.

For Propane, the minimum inlet gas supply pressure for the purpose of input adjustment is 11-inches water column. The maximum inlet gas supply pressure is 13-inches water column.

Gas pressure and input to the burners must not exceed the rated input and pressure shown on the nameplate.

### ORIFICE SIZES

The efficiency rating of this appliance is a product Annual Fuel Utilization Efficiency rating determined under continuous operating conditions and was determined independently of any installed system.

This furnace is equipped with a automatically controlled modulating valve and power burner. For elevations above 2,000 feet, adjust thermostat settings to the appropriate elevation during installation.

The gas supply line must be of adequate size to handle the BTU/hr. requirements and length of the run for the unit being installed.

Determine the minimum pipe size from **Figure 13**, based on the length of the run from the gas meter to the unit.

**FIGURE 13 - PIPE CAPACITY**

#### PIPE CAPACITY - BTU/hr. WITH FITTINGS

NATURAL GAS			
LENGTH OF PIPE FEET	PIPE SIZE		
	1/2"	3/4"	1"
20	92,000	190,000	350,000
40	63,000	130,000	245,000
60	50,000	105,000	195,000
PROPANE			
LENGTH OF PIPE FEET	PIPE SIZE		
	1/2"	3/4"	1"
20	189,000	393,000	732,000
40	129,000	267,000	504,000
60	103,000	217,000	409,000

All piping must comply with local codes and ordinances or with the National Fuel Gas Code (ANSI Z223.1 NFPA No. 54), whichever applies. (In Canada: CAN/C.GAB149). Refer to **FIGURE 14** for the general layout of the unit. It shows the basic fittings needed.

The following rules apply:

1. Use new, properly reamed steel or black iron pipe and fittings free of metal chips and debris that are approved by local codes. Metal chips and debris can damage the valve.
2. Do not thread pipe too far. Valve distortion or malfunction may result from excess pipe within the gas control valve. Apply a moderate amount of good quality dope to the pipe only. Leave the two end threads bare. (**Figure 15**).
3. Use ground joint unions.
4. Install a drip leg (sediment trap) to trap dirt and moisture before it can enter the gas valve. The nipple must be a minimum of 3-inches long.
5. Install a manual shutoff valve.
6. Provide a 1/8" NPT test gauge connection immediately before the gas supply connection to the furnace.

# INSTALLING YOUR FURNACE

## GAS CONNECTION

Use two pipe wrenches when making the connection to the valve to prevent turning and/or damage to the valve.

Connections between the manual shutoff valve and burner control assembly can be made with an A.G.A./C.G.A. design certified flexible connector if allowed by local codes. Drip leg and ground joint unions are still required.

Tighten all joints securely.

Test all piping for leaks. When checking gas piping to the furnace with gas pressure less than 1/2 PSI, shut off manual gas valve to the furnace. If gas piping is to be checked with the pressure at or above 1/2 PSI, the furnace and manual shutoff valve must be disconnected during testing. (SEE WARNING). Apply soap solution (or a liquid detergent) to each joint. Bubbles forming indicate a leak. Correct even the slightest leak at once.

**⚠ WARNING:** Danger of property damage, bodily injury or death. Never use a match or open flame to test for leaks. Never exceed specified pressures for testing. Higher pressures may damage the gas valve and cause over-firing which may result in component(s) failure. Never attempt start-up of unit before thoroughly ventilating the area and smelling near the floor for gas odor.

**FIGURE 15 – PROPER PIPING PRACTICE**

**FIGURE 14 – GAS PIPING**

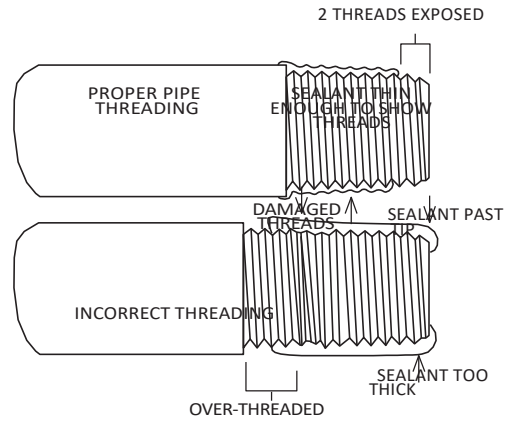
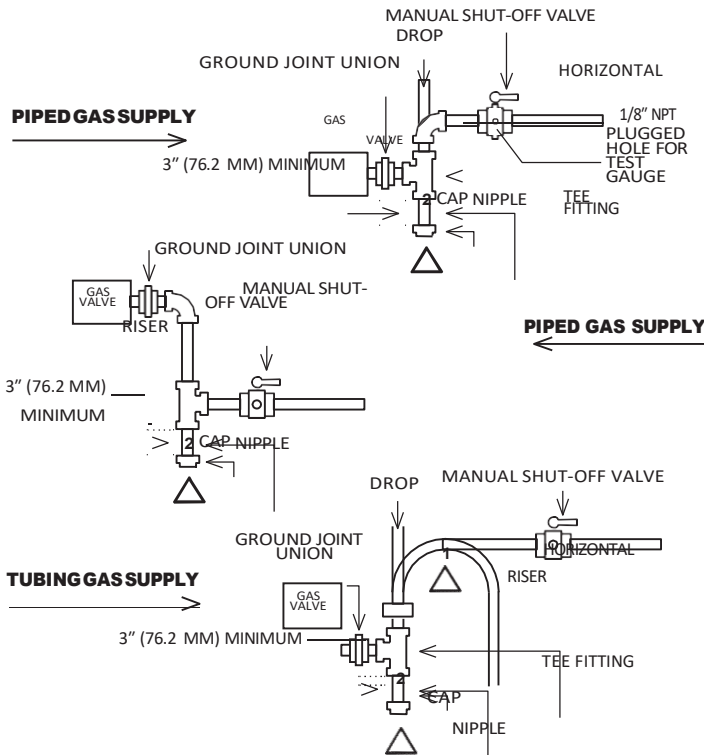

- 1 **CAUTION:** All bends in metal tubing must be smooth.
- 2 **CAUTION:** Shut off the main gas supply before removing the end cap to prevent gas from filling the work area. Test for gas leakage when installation is complete.

## Front Panel Installation

Place the front panel top over the channel on the header plate, as shown in **Figure 16**. Press the panel tight against wall, and secure it to the header channel with the screw provided in final assembly package. Open the control door at bottom of panel and fasten the panel at each side through slots in flanges with screws provided.

Attach handle to the front panel door with the screw provided.

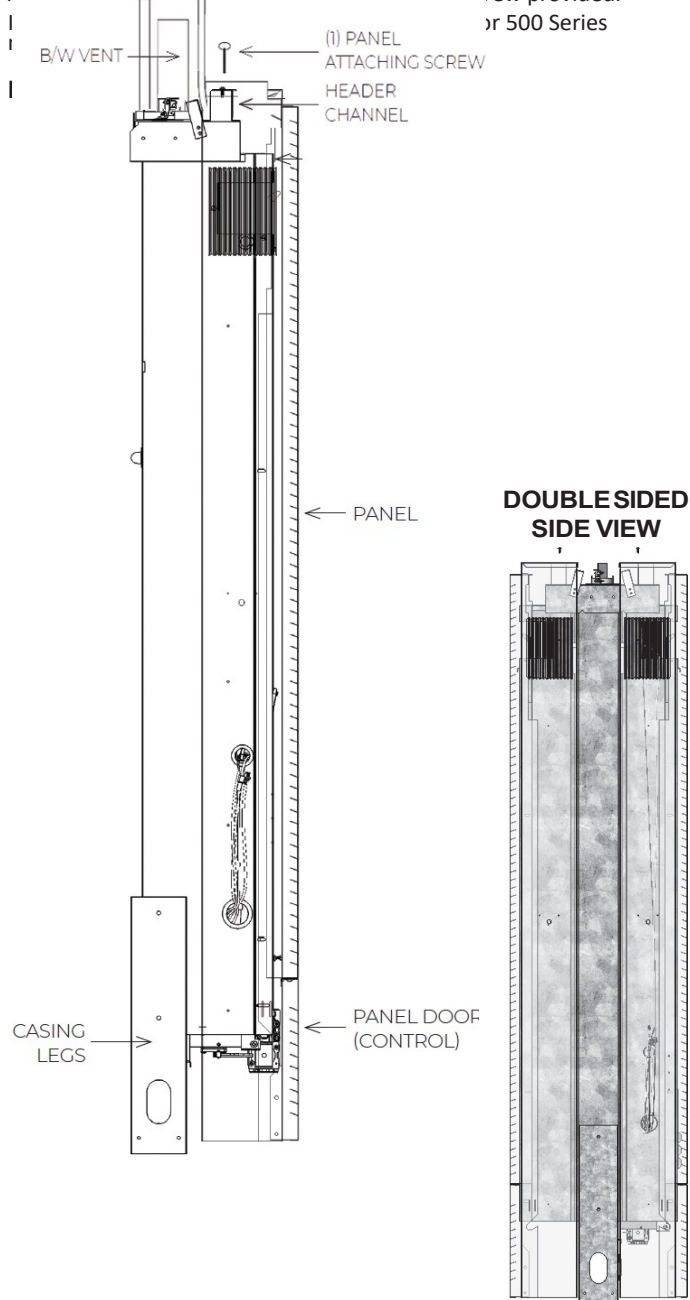

## Thermostat Installation

Use the thermostat supplied with the unit.

1. Use cable supplied with the unit.
2. If a new location is chosen or if this is a new installation, thermostat cable must first be run to the location selected. These instructions cover bringing the cable down from the attic but it may be run from a basement or crawl space using similar methods.
3. Before drilling a hole in the wall at the selected location, drive a small finish nail through the ceiling in the corner of the wall and ceiling above the thermostat location. Pull the nail out and push a small, stiff wire through the hole so it can be found in the attic. Drill a ½-inch hole through the ceiling wall plate. Drill a ½-inch hole through the ceiling wall plate.
4. Probe for obstructions in the partition. Then, drill a ½-inch to 1-inch hole through the wall at the selected location for the thermostat.
5. From the attic, feed the thermostat cable through the wall until even with the thermostat location.
6. Snag the thermostat cable through the hole and pull the cable through the hole in the wall so that 6-inches of the cable protrude.
7. Route cable to the furnace.
8. Never use nails or staples across the thermostat cable.

### WALL-MOUNTED THERMOSTAT INSTALLATION

1. Mount thermostat mounting plate on wall making sure the opening on the plate matches up with the hole in the wall where the thermostat cable will be threaded through.
2. Thread thermostat cable through the hole in the wall and mounting plate.
3. Connect thermostat cable to thermostat.
4. Mount thermostat onto mounting plate.

**IMPORTANT:** Keep the thermostat cable away from the combustion chamber.

**FIGURE 17 – THERMOSTAT SETTINGS**

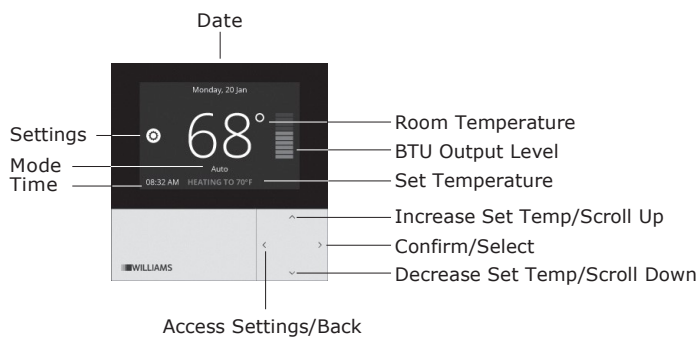

# START-UP PROCEDURE

Check the furnace operation as outlined in the following instructions. If any sparking, odors or unusual noises are encountered, shut off electric power immediately. Recheck for wiring errors or obstructions in or near fan motor (if equipped).

**⚠ WARNING:** Natural gas heating value (BTU per cubic foot) can vary significantly. Therefore, it is the installer's responsibility to see that BTU/hr. input to the furnace is adjusted properly. Failure to do so could cause combustion chamber failure, asphyxiation, fire or explosion resulting in damage, bodily injury or death. Refer to the National Fuel Gas Code (NFPA 54) to be sure the furnace is burning fuel at the proper rate.

## Check gas input and pressures

This furnace **may not be used at elevations above 4,500 Feet.**

Gas supply pressure and manifold pressure with the burner operating must also be as specified on the nameplate.

Rated input will be obtained on a heating value of 2,500 BTU/hr. with factory-sized orifices. If Propane, having a different heating value is supplied, orifices must be changed by a qualified service technician before the furnace is operated. **CAN NOT BE MODIFIED TO BE USED ABOVE 4,500 FEET**

## CHECK THE MANIFOLD GAS PRESSURE

Types of Gas	AC2030 Manifold Pressure in W.C.	AC3040 Manifold Pressure in W.C.
Natural	3.4	3.5
Propane	7.4	7.6

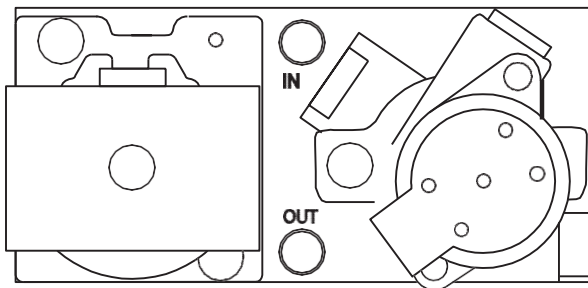

A tapped opening is provided in the gas valve to facilitate measuring manifold gas pressure. A water column manometer having a scale range from 0 to 12-inches of water column should be used for this measurement. The manifold pressure must be measured with the burner and pilot operating. Any major changes in the flow must be made by changing the size of the burner orifice.

## CHECK THE GAS INPUT (NATURAL GAS ONLY)

Under firing could cause inadequate heat, excessive condensation or ignition problems. Over firing could cause shooting flame impingement or overheating of the

combustion chamber. Before starting natural gas input check, obtain the heating value of gas (BTU per cubic foot) at standard conditions from your local gas supplier.

To measure the input, using the gas meter, proceed as follows:

1. Turn off gas supply to all other appliances except the furnace.
2. With the furnace operating, time the smallest dial on the meter for one complete revolution. If this is a 2-cubic-foot dial, divide the seconds by 2. If it is a 1-cubic-foot dial, use the time in seconds as is. This gives the seconds per cubic foot of gas being delivered to the furnace.
3. Assuming natural gas with a heating value of 1,000 BTU per cubic foot and 34-seconds per cubic foot used as determined by step (2), then: Seconds per hour = 3,600 Input = 1,000 x 3,600 / 34 = 106,000 BTU/hr. This measured input must not be greater than the input indicated on the nameplate of the furnace.
4. Relight all other appliances turned off in Step 1 above. Be sure all pilots are operating.

## CHECK THERMOSTAT

Check thermostat operation. The thermostat will turn on the furnace when room temperature falls 2°F below the thermostat set point for more than 1 minute. The thermostat will turn off the furnace when the room temperature is more than 1°F over set point for more than 1 minute.

## CHECK CONTROL WIRING CONNECTIONS

Refer to wiring diagram on page 28.

## BURNER FLAME CHARACTERISTICS

Start the furnace and let it operate at least ten minutes. Observe the flame from the Sight Window. The flame should turn to blue color with scattered dots of yellow color within 2 minutes of ignition. Limit your movements near the furnace a few more minutes before making your final observations. The flame may look yellow due to dust particles in the room air or a clogged filter on the combustion fan. An occasional flash of orange might be seen as dust particles burn in the flame. This is normal. No burner adjustment is provided, or is necessary. **(Figure 18).**

**FIGURE 18 – BURNER FLAME CHARACTERISTICS**

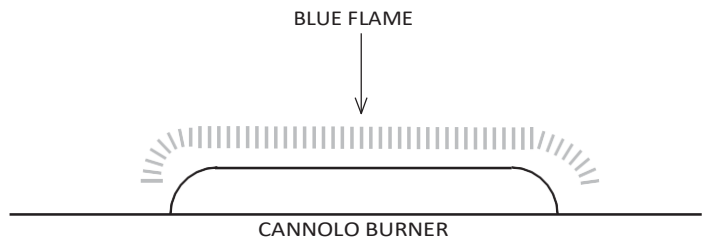

## NORMAL APPEARANCE

### NATURAL GAS:

1. Blue Colored Flame with scattered yellow dots
2. Flame would rise approximately 1/2 inch - 3/4 inch above the burner ports

### ABNORMAL APPEARANCE

1. Completely yellow colored flame indicating a very rich mixture
2. Blue Colored Flame rising very high above the burner ports and almost detaching from the ports indicating a very lean mixture

**WARNING:** If flame appears abnormal, contact the gas company or a qualified service technician immediately.

## Operation Of Your Furnace

### The furnace operates in the following sequence:

1. Switch on the Thermostat. The gas valve opens to allow gas flow to the burner and the combustion fan starts to supply combustion air to ignite the burner
2. Heat builds up in the furnace and starts the fan. The heated air comes out across the Heat Exchanger tubes.
3. When thermostat setting is reached, the gas valve stops gas to the burner and the unit is shutdown.

**WARNING:** The surface of the furnace is hot during operation. Keep children, clothing, furniture, and flammable material away from it. Keep all access doors and panels in place except for inspection and maintenance. On new installations, the gas lines will be filled with air and it may take several minutes to establish the flame.

**WARNING:** Danger of property damage, bodily injury or death. If the furnace overheats or fails to shut off, close manual shutoff gas valve to the furnace before turning off electrical power to the accessory fan.

**IMPORTANT:** KEEP BURNER AND CONTROL COMPARTMENT CLEAN. BURNER IS INACCESSIBLE AND CANNOT BE CLEANED UNLESS REPLACED

**WARNING:** OBSERVE ANY LOUD NOISE OR FLASH BACK WHEN THE COMBUSTION IS INITIATED. IF IT DOES, CONTACT THE REPRESENTATIVE

## FOR YOUR SAFETY READ BEFORE LIGHTING

**WARNING: IF YOU DO NOT FOLLOW THESE INSTRUCTIONS EXACTLY, A FIRE OR EXPLOSION MAY RESULT CAUSING PROPERTY DAMAGE, PERSONAL INJURY, OR LOSS OF LIFE.**

- A. BEFORE LIGHTING: smell all around the appliance area for gas. Be sure to smell next to the floor because some gas is heavier than air and will settle on the floor.
- B. Use only the thermostat and power ON/OFF switch on the control unit at the bottom of the furnace to turn the gas control on/off. Any attempted repairs or adjustments should be performed by a qualified service technician. Applying force or attempted repair may result in a fire or explosion.
- C. Do not use this appliance if any part has been under water. Immediately call a qualified service technician to inspect the appliance and to replace any part of the control system and any gas control which has been under water.
- WHAT TO DO IF YOU SMELL GAS**
- Do not try to light any appliance.
  - Do not touch any electrical switch.
  - Do not use any phone in your building.
  - Immediately call your gas supplier from a neighbor's phone. Follow the gas supplier's instructions.
  - If you can not reach your gas supplier, call the fire department.

## LIGHTING INSTRUCTIONS

1. STOP! Read the safety information above on this label.
2. Turn off the remote thermostat and power ON/OFF switch on the control unit at the bottom of the furnace.
3. Open bottom louver assembly, or open the service access panel.
4. Turn off all electric power to the appliance.
5. Turn gas line valve to "ON"
6. Wait five (5) minutes to clear out any gas. Then smell for gas including near the floor. If you smell gas, STOP! Follow A in the safety above. If you do not smell gas, go to the next step.
7. Turn on all electric power to the appliance.
8. Turn on the thermostat and power ON/OFF switch on the control unit at the bottom of the furnace, and set thermostat to desired setting (if available). Activate appliance using display panel.
9. This appliance is equipped with an ignition device that automatically lights the burner. Do not try to light the burner by hand.
10. If the appliance will not operate, follow the instruction "TO TURN OFF GAS TO APPLIANCE", and call your service technician or gas supplier.
11. Close bottom louver assembly, or close the service access panel.

## TO TURN OFF GAS TO APPLIANCE

1. STOP! Read the safety information above.
2. Open bottom louver assembly, or open the service access panel.
3. Turn off all electric power to the appliance.
4. Turn gas line valve to "OFF".
5. Close bottom louver assembly, or close service access panel.

**IMPORTANT:** KEEP BURNER AND CONTROL COMPARTMENT CLEAN.

**WARNING:** Due to high surface temperatures, keep children, clothing, furniture or any combustible material away from the furnace.

# CARING FOR YOUR FURNACE

## How To Care For Your Furnace

**⚠ WARNING:** Danger of bodily injury or death. Turn off electric power supply at disconnect switch, fuse box or service panel before removing any doors or access service panels from unit.

### ANNUAL UPKEEP NEEDED

It is recommended that a qualified service technician perform these maintenance checks at the beginning of each heating season.

### CABINET FINISH

Clean cabinet with damp cloth. Never use abrasive cleaners. Cabinets are finished with heat resistant powder paint.

Never refinish or paint.

### FURNACE AREA

Keep the area near the furnace clear and free from combustible materials, gasoline and other flammable liquids and vapors.

### COMBUSTION AND VENTILATION AIR

The combustion and ventilation air supply must not be blocked. Do not put anything in or on the furnace cabinet. For better circulation and more effective heating, do not place obstructions, furniture or other items closer than four- feet in front of the furnace or two-feet from each side of the furnace.

### CLEANING BLOWER

Shut off electricity. Clean any lint or dirt from fan blades, fan motor and exposed air passages.

### VENT SYSTEM

Make sure that no parts of the venting system are blocked or rusted. Clean or replace before using the furnace.

**DANGER:** The build-up of any dust, lint or foreign material in the combustion fan filter can interfere with the proper air gas mixture and can result in a yellow flame which can produce carbon monoxide and soot. This condition, if allowed to develop, can lead to bodily injury including death. It is imperative that the burner be kept clean.

**CAUTION:** Danger of property damage, bodily injury or death. Turn off electric power supply at the disconnect switch, fuse box or service panel before removing or working on the fan cabinet.

FIGURE 19 – DISCONNECTING GAS LINE

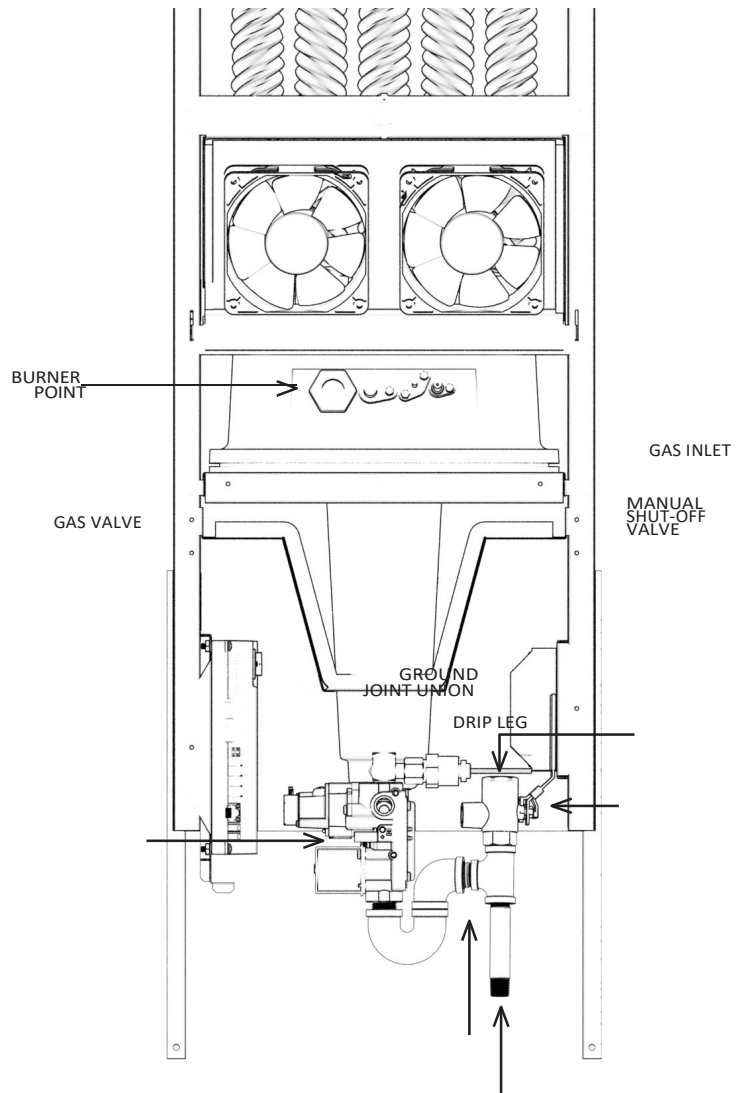

# INSTALLING YOUR MOTORIZED REAR OUTLET ACCESSORY

## Motorized Rear Outlet Register 6920

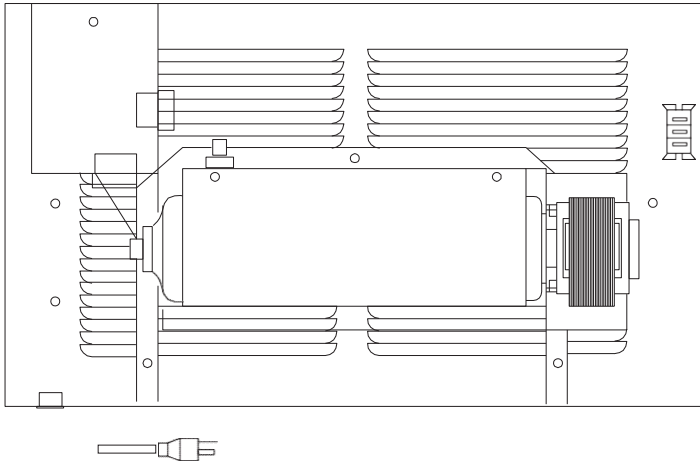

**⚠ WARNING:** Danger of property damage, bodily injury or death. Turn off all electrical power supply at disconnect switch, fuse box or service panel before removing or working on fan. For your protection against shock hazard, this appliance is equipped with a three-prong (grounding) plug and should be plugged directly into a properly grounded three-prong receptacle. Do not cut or remove the prong. All electrical work must conform to your local codes and ordinances or in their absence, with National Electrical Code ANSI/NFPA 70. In Canada, use the Canadian Electrical Code C22.1. If you are not familiar with the wiring codes in general, have a competent electrician do this job.

### LOCATION WARNING

This register must be centered between studs and aligned with the furnace for proper engagement. Make sure the furnace is centered between the same studs before you cut any wall openings for the register.

1. Measure and mark wall for opening as shown in **Figure A**. Check the wall for any electrical wiring present before cutting the opening. Reroute existing electrical if necessary.
2. If recessed-mounted installation, place the plaster ground in the opening and attach to the 2x4 studs.
3. An embossed knockout plate is located on the rear of the outer shield and another is located directly behind it on the inner shield. (**Figure B**). Remove the knockout plates on the furnace by punching in the lower corners of the plate with a screwdriver blade. Then, holding the screwdriver blade sideways against the side and bottom connecting tabs, strike the head of the screwdriver lightly with a hammer to break the tabs. Swing the plate outward and bend it back and forth to break the top tabs. Both knockout plates must be removed in order to attach the register assembly properly. If the inner shield knockout is not embossed deep enough to be removed easily, mark an outline using the existing opening as a guide. Use tin snips to cut the area away. A pilot hole may be needed to begin the first cut. Take care not to damage the combustion chamber directly behind the inner shield when making a pilot hole.
4. Attach speed nuts to the outer shield (**Figure B**). After the furnace is in position, insert the outlet register into the opening as shown in **Figures C, D and E**. Install machine screws through the register housing and into the speed nut clips on the furnace outer shield. Do not over tighten the screws.
5. After the register has been either wired, (**Figure F**), or plugged in, set the fan switch to the desired blower operation.

**CAUTION:** Do not install this kit where the outlet grille may be blocked or covered by a door, curtains or any other obstructions.

### MOTORIZED REAR OUTLET REGISTER 6920

This Rear Outlet Register directs some of the heated air into the room opposite the one in which the furnace is installed. Read these instructions carefully and familiarize yourself with the installation before you begin. Use gloves to protect your hands from sharp metal edges.

### BLOWER SETTINGS

You must select "ON" for continuous blower operation or "AUTO" for automatic setting. If the blower is set on "AUTO" when the furnace heats up, the heat sensor switch is activated and the blower will operate until the furnace cools down, then the blower will turn off. The blower will not operate if fan switch is set in the "OFF" (center) position.

# INSTALLING YOUR MOTORIZED REAR OUTLET ACCESSORY

FIGURE A – RECESSED & SURFACE INSTALLATION

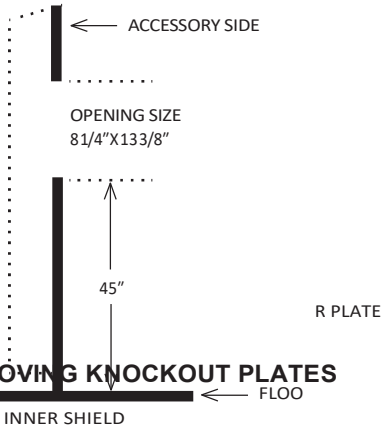

FIGURE B – REMOVING KNOCKOUT PLATES

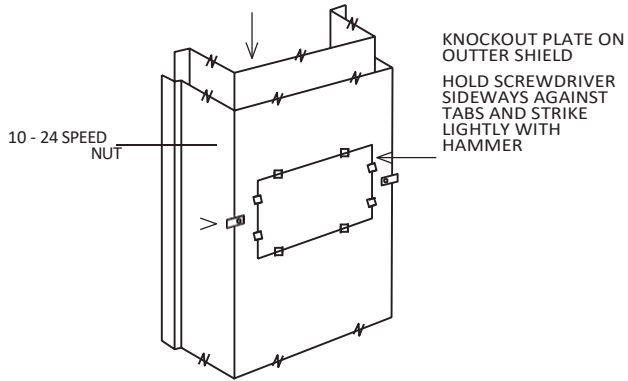

FIGURE C – SURFACED MOUNTED INSTALLATION

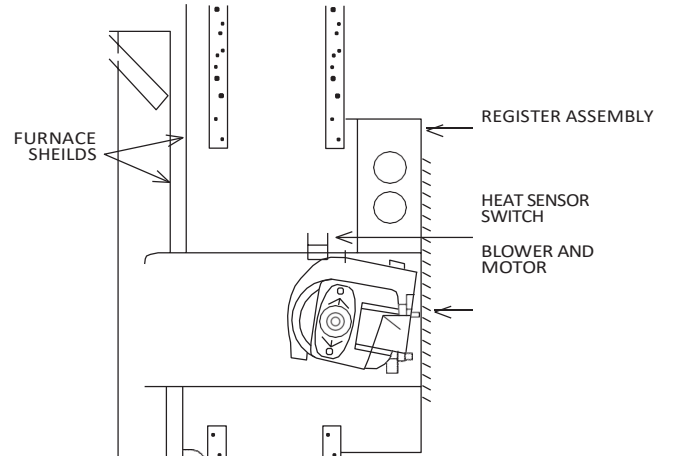
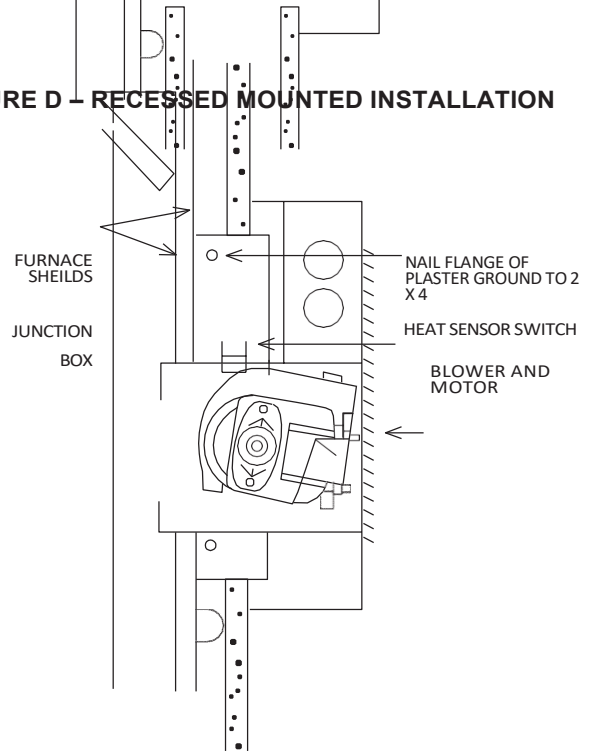
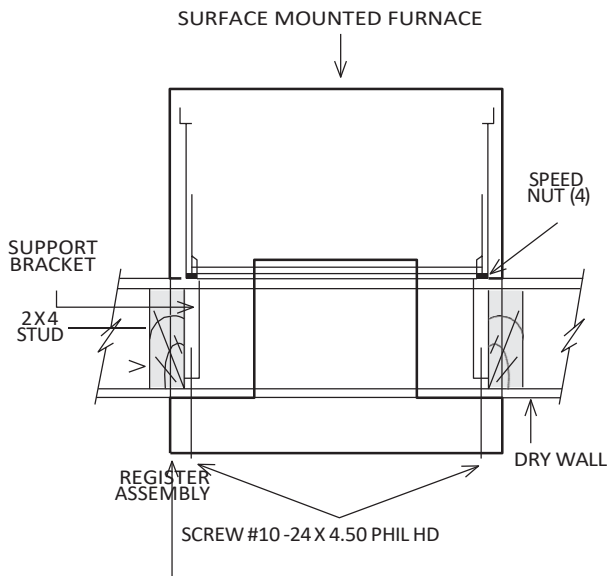

FIGURE D – RECESSED MOUNTED INSTALLATION



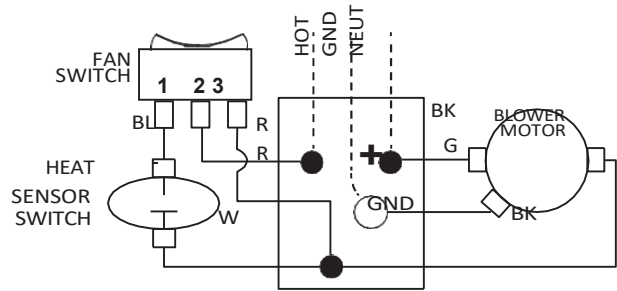

**FIGURE E – SURFACED MOUNTED INSTALLATION**

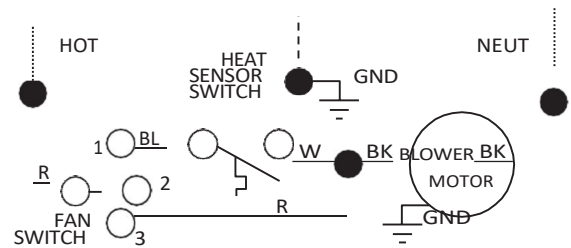

**FIGURE F – WIRING**

SWITCH LEGEND 1 - ON  
2 - OFF  
3 - AUTO



**115V 60Hz**



**LEGEND**

- high voltage field high voltage factory
- wire connector for line voltage - factory wiring
- 1/4 quick connect terminals for factory wiring connections.
- BK = BLACK
- BL = BLUE
- W = WHITE
- R = RED
- G = GREEN

**NOTES:**

1. Motor is thermally protected.
2. If any of the original wire as supplied with the appliance must be replaced, it must be replaced with (105°) wire or it's equivalent.

Total electrical load less than 3 AMPS.

# MOTORIZED REAR OUTLET REPLACEMENT PARTS

Motorized Rear Outlet – Model 6920

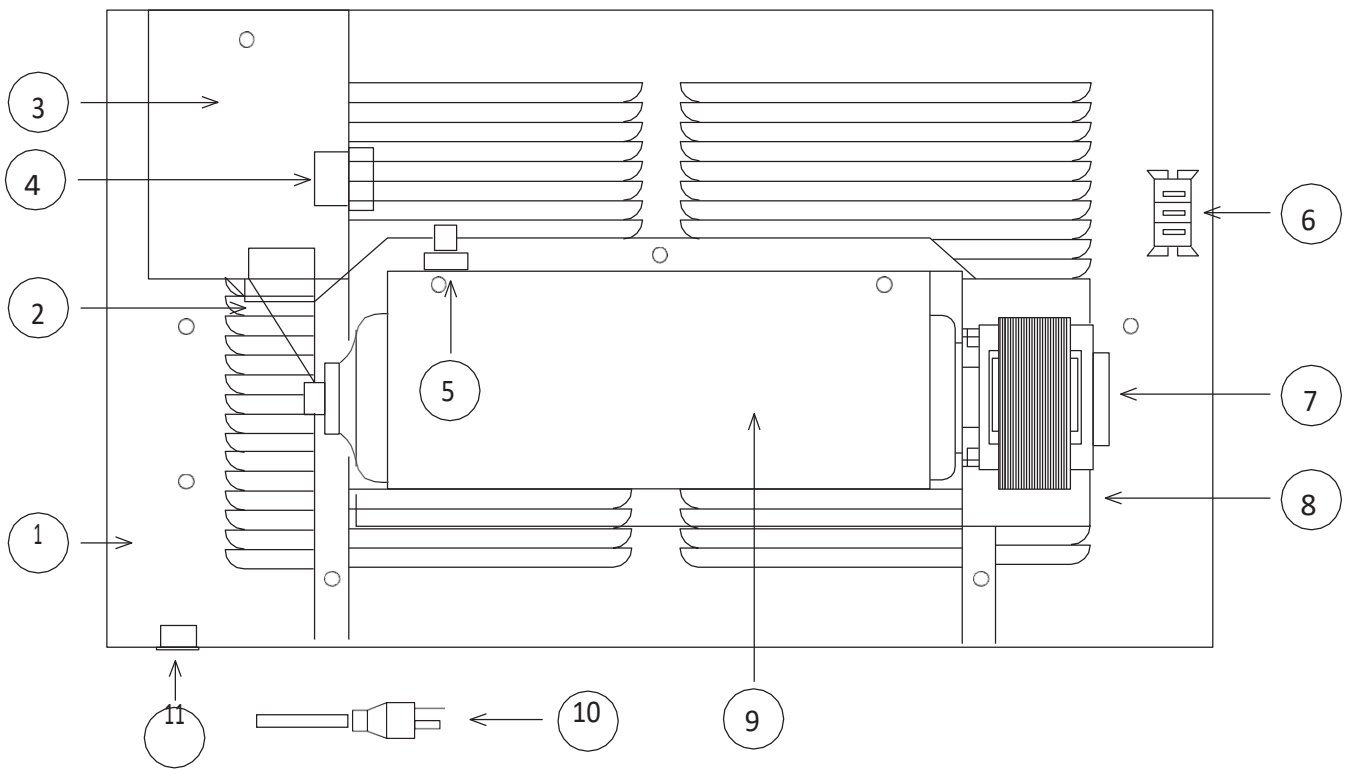

Motorized Rear Outlet Replacement Parts List – Model 6920

Reference Number	Description	Part Number
		6920
1	Register Assembly	9B285
2	Strain Relief Bushing	P500185
3	J-Box Cover	9A427
4	Strain Relief Brushing	P603108
5	Heat Sensor Switch	P323172
6	Fan Switch	P323080
7	Motor and Blower	P323423
8	Motor Cover	9A462
9	Motor Housing Back Plate	9B284
10	Cord and Plug	P323081
11	Bushing	P323084

Use only manufacturer's authorized parts.  
 NOTE: Nuts, bolts, screws, and washers are standard hardware items and may be purchased locally.

# FURNACE REPLACEMENT PARTS

## Replacement Parts - **SINGLE SIDED**

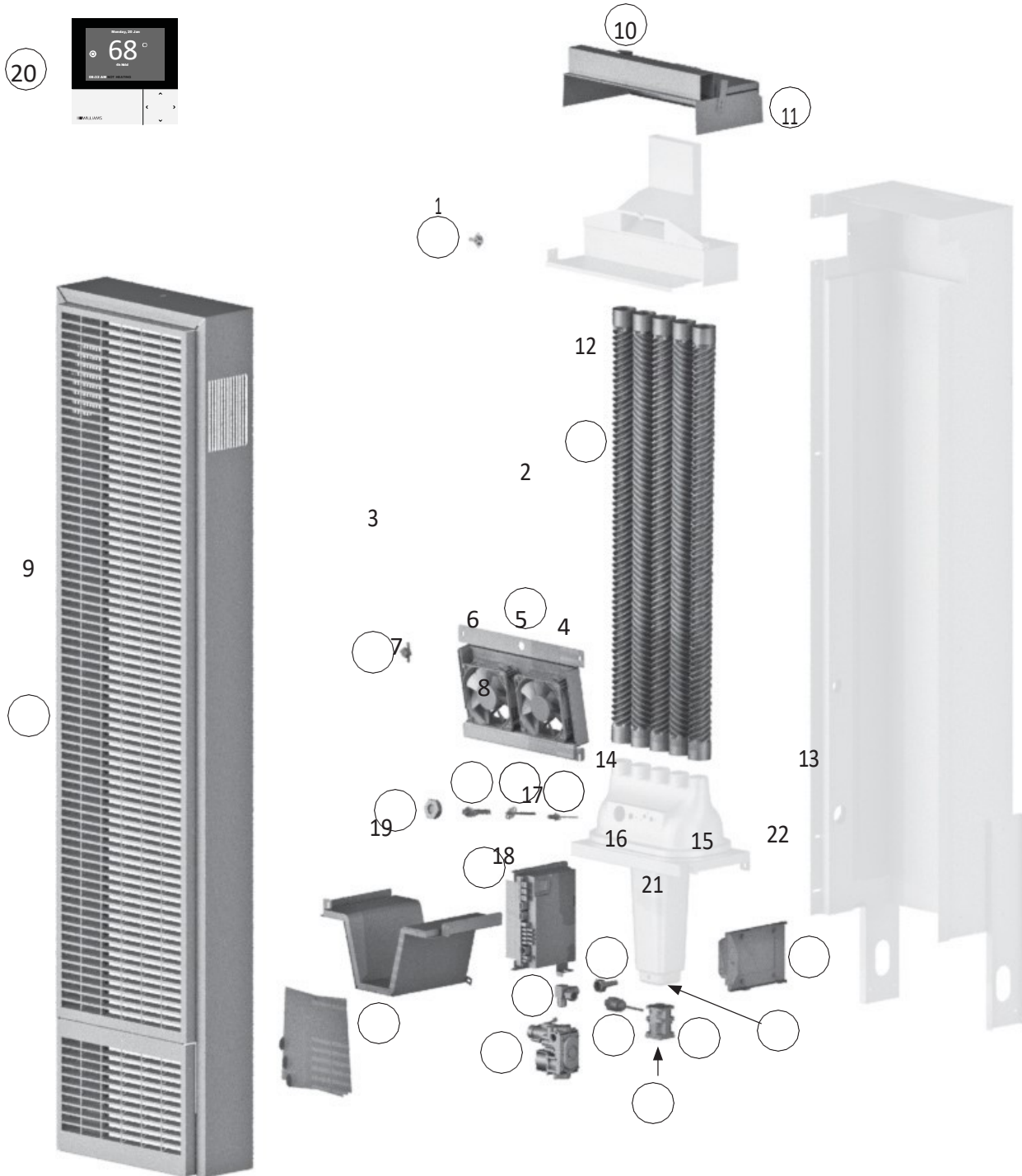

DRAWING REF NO.	KIT NUMBER AC2030TN	KIT NUMBER AC2030TP	DESCRIPTION
not shown	–	M117854	CONVERSIONKITPROPANETONATURALGAS
not shown	M117853	–	CONVERSIONKITNATURALGASTOPROPANE

DRAWING REF NO.	PART NUMBER AC2030TN	PART NUMBER AC2030TP	DESCRIPTION
1	P323834	P323834	VENT LIMIT SWITCH
2	M116840	M116840	CIRCULATION FAN ASSEMBLY
3	P323828	P323828	HIGH LIMIT SWITCH
4	M117837	M117837	FLAME SENSOR
5	M117836	M117836	THERMOCOUPLE PROBE
6	M117838	M117838	HOT SURFACE IGNITER
7*	M117255	M117255	SIGHT WINDOW
8	M117149	M117149	CONTROL MODULE ASSEMBLY
9	4915	4915	FRONT PANEL
10	M117435	M117435	VENT PRESENCE SWITCH
11	M117283	M117283	HEADER ASSEMBLY
12	M117285/M117287	M117285/M117287	HEAT EXCHANGER TUBE ASSEMBLY
13	M117148	M117148	IGNITION MODULE ASSEMBLY
14**	P323777	P323845	ORIFICE
15	P323732	P323732	COMBUSTION FAN
16**	P323806	P323806	PRESSURE SENSOR
17**	P323790	P323790	MANIFOLD ASSEMBLY
18**	P323822	P323846	STEPPER GAS VALVE
19	M117500	M117500	LABEL ASSEMBLY
20	P323744	P323744	THERMOSTAT
21	P323768	P323768	COMBUSTION FAN FILTER
22	M117535	M117535	COMBUSTION FAN GASKET

\* Apply DEACON 8875-THIN high temperature thread sealant (P323827) while installing 7

\*\* Apply regular thread sealant (or P141101) while installing 14, 16, 17, 18

# FURNACE REPLACEMENTPARTS

## Replacement Parts - **DOUBLESIDED**

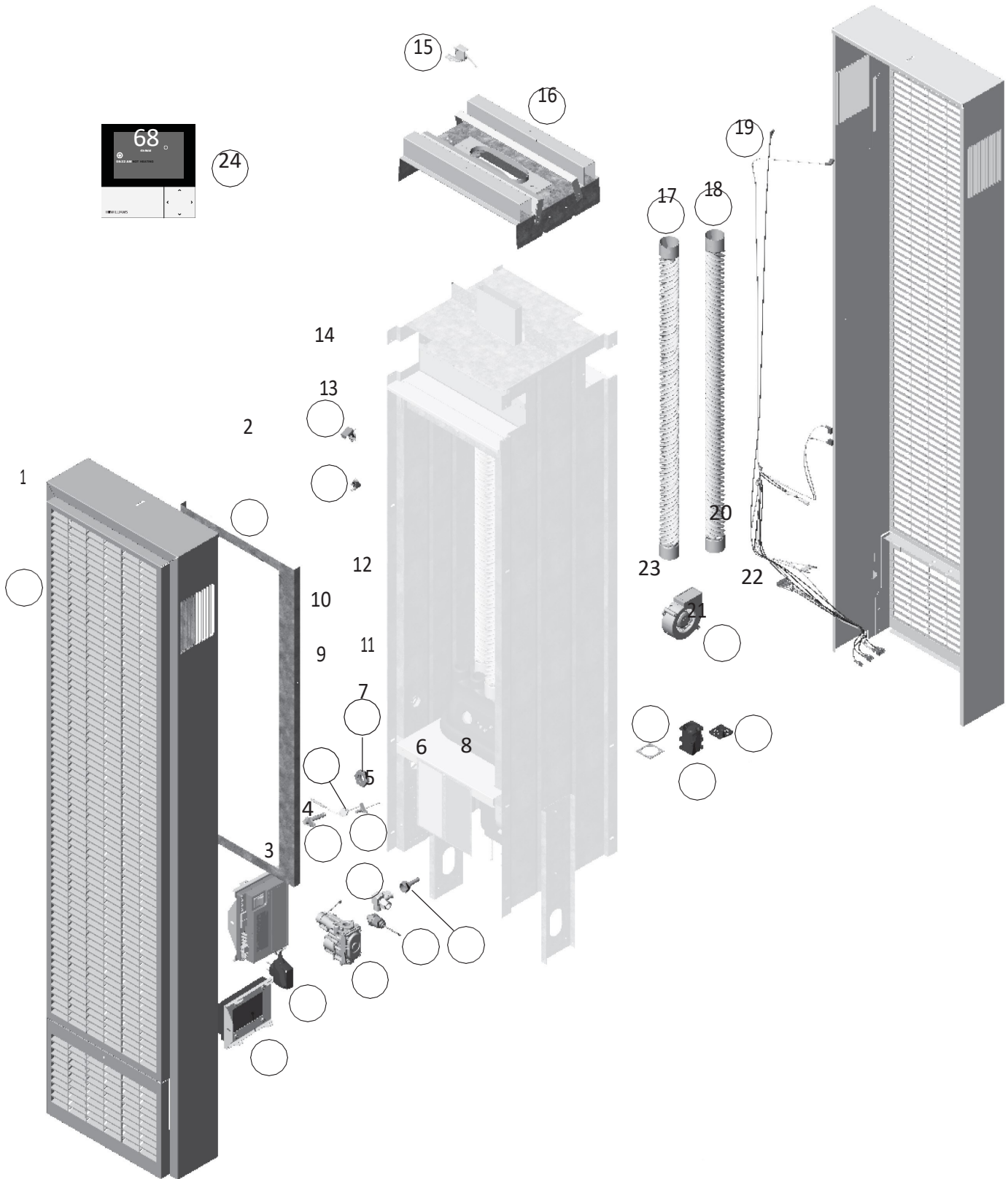

DRAWING REF NO.	KIT NUMBER AC3040TN	KIT NUMBER AC3040TP	DESCRIPTION
not shown	M117881	M117881	CONVERSIONKITPROPANETONATURALGAS
not shown	M117880	M117880	CONVERSIONKITNATURALGASTOPROPANE

DRAWING REF NO.	PART NUMBER AC3040TN	PART NUMBER AC3040TP	DESCRIPTION
1	4915	4915	FRONT PANEL
2	M117720	M117720	REINFORCEMENT BRACKET
3	M117148	M117148	IGNITION MODULE ASSEMBLY
4	M117149	M117149	CONTROL MODULE ASSEMBLY
5**	P323822	P323846	STEPPER GAS VALVE
6**	P323806	P323806	PRESSURE SENSOR
7**	P323790	P323790	MANIFOLD ASSEMBLY
8**	P323849	P323871	ORIFICE
9	M117838	M117838	HOT SURFACE IGNITER
10	M117836	M117836	THERMOCOUPLE PROBE
11	M117837	M117837	FLAME SENSOR
12*	M117255	M117255	SIGHT WINDOW
13	P323828	P323828	HIGH LIMIT SWITCH
14	P323834	P323834	VENT LIMIT SWITCH
15	M117435	M117435	VENT PRESENCE SWITCH
16	M117710	M117710	HEADER PLATE ASSEMBLY
17	M117285	M117285	HEAT EXCHANGER TUBE ASSEMBLY OPPOSITE
18	M117287	M117287	HEAT EXCHANGER TUBE ASSEMBLY
19	P323860	P323860	WIRE HARNESS
20	P323861	P323861	CIRCULATION FAN
21	P323732	P323732	COMBUSTION FAN
22	P323758	P323758	COMBUSTION FAN FILTER
23	M117535	M117535	COMBUSTION FAN GASKET
24	P323744	P323744	THERMOSTAT

\* Apply DEACON 8875-THIN high temperature sealant while installing.

\*\* Apply regular thread sealant (or P141101) while installing.

# WIRING DIAGRAM

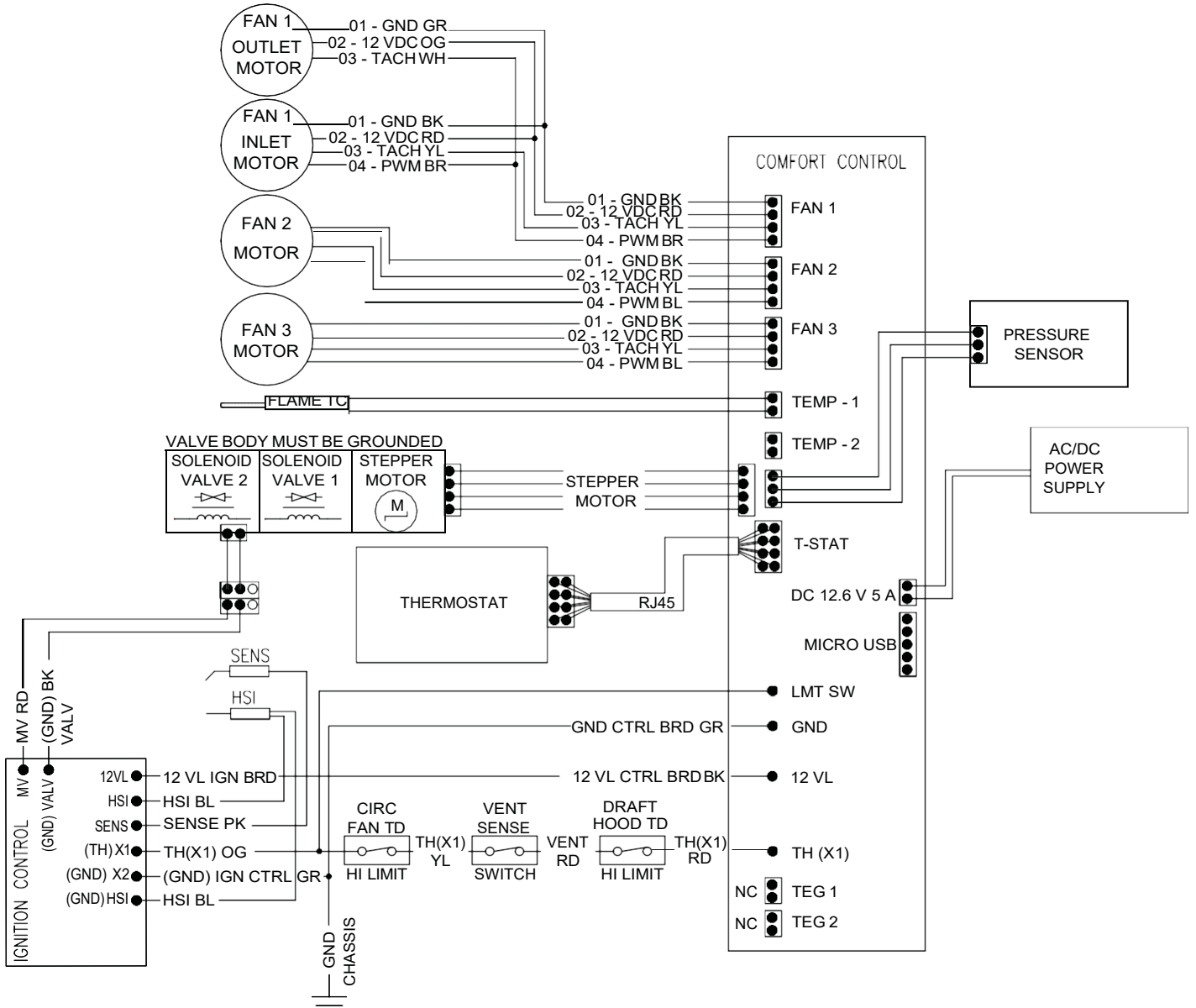



# HINTS AND INFORMATION

If your furnace fails to work correctly, you may avoid the inconvenience and cost of a service call by checking the troubleshooting section on pages 34 and 35 before you call for service.

 **WARNING:** If the information in this manual is not followed exactly, a fire or explosion may result causing property damage, personal injury or loss of life.

**DO NOT** store or use gasoline or other flammable vapors and liquids in the vicinity of this or any other appliance.

## HOW TO ORDER REPAIR PARTS

When ordering repair parts, always give the following information:

1. MODEL NUMBER
2. MFG. DATE CODE
3. PART NUMBER
4. PART DESCRIPTION

All parts listed herein may be ordered from your equipment supplier. The Model Number of your Williams wall furnace will be found on the nameplate near gas valve, inside control compartment.

## WHAT TO DO IF YOU SMELL GAS

- Open all of the windows.
- Do not try to light any appliance.
- Do not touch any electrical switch.
- Do not use any phone or cell phone in your building.
- Extinguish any open flame.
- Immediately call your gas supplier from a neighbor's phone. If you cannot reach your gas supplier, call the fire department.

Installation and service must be performed by a qualified installer, service agency or the gas supplier.

# TROUBLESHOOTING YOUR FURNACE

ISSUE	POSSIBLE CAUSE(S)	CORRECTIVE ACTION
1. Furnace won't turn on	<ul style="list-style-type: none"> <li>A. AC power is not connected</li> <li>B. Control module power button is set to OFF</li> <li>C. Thermostat is set to OFF</li> <li>D. Thermostat cable is not connected</li> </ul>	<ul style="list-style-type: none"> <li>A. Check power cord connection</li> <li>B. Control module power ON</li> <li>C. Turn thermostat to ON</li> <li>D. Connect thermostat cable</li> </ul>
2. Furnace calls for heat but won't ignite	<ul style="list-style-type: none"> <li>A. Exhaust vent not installed correctly and not closing safety switch</li> <li>B. Gas supply off</li> <li>C. Unit is overheating, high temp limit switch tripped</li> <li>D. Hot surface igniter failed</li> <li>E. Thermostat not calling for heat</li> <li>F. Plugged furnace orifice.</li> <li>G. Defective thermostat</li> <li>H. Defective valve.</li> <li>I. Combustion fan is defective</li> <li>J. Control module defective</li> <li>K. Ignition Module defective</li> <li>L. Temperature probe faulty</li> <li>M. Ground is not connected</li> <li>N. Thermostat not communicating with the Control Module</li> </ul>	<ul style="list-style-type: none"> <li>A. Verify exhaust vent is installed per instructions</li> <li>B. turn on gas supply</li> <li>C. Verify nothing is blocking the front panel, check circulation fan operation</li> <li>D. Replace igniter</li> <li>E. Increase Set Point Temperature</li> <li>F. Check clean or replace.</li> <li>G. Replace thermostat</li> <li>H. Check connections at valve terminals. If valve operates, Check for blocked burner orifices.</li> <li>I. Check wiring connections or replace</li> <li>J. Replace control module</li> <li>K. Replace ignition module</li> <li>L. Check wiring connections or replace</li> <li>M. Check wiring connections or replace</li> <li>N. Verify the STM 32 version as shown in Thermostat setting Controls</li> </ul>
3. Furnace operates but turns off before room temperature is attained	<ul style="list-style-type: none"> <li>A. Thermostat location..</li> <li>B. Defective thermostat.</li> <li>C. Unit is overheating, high temp limit switch tripped</li> <li>D. Room fans defective</li> <li>E. Flame sensor defective</li> <li>F. Exhaust vent is blocked</li> </ul>	<ul style="list-style-type: none"> <li>A. Check thermostat location. It should not be in the path of warm air discharge from furnace, near a lamp or above a T.V. or stereo unit.</li> <li>B. Check thermostat calibration or replace.</li> <li>C. Verify nothing is blocking the front panel, check circulation fan operation</li> <li>D. Verify room fan operation</li> <li>E. Replace flame sensor</li> <li>F. Verify exhaust vent is installed per instructions</li> </ul>

ISSUE	POSSIBLE CAUSE(S)	CORRECTIVE ACTION
4. Furnace not producing sufficient heating.	A. Furnace may be too small for space being heated	A. Check heat sizing calculations.
5. Furnace operates but will not shut off when room temperature is attained.	A. Thermostat wiring defective.	A. Thermostat lead wires may be shorted together, caused by a nail or staple. Check by removing thermostat leads from valve terminals.
	B. Thermostat location.	B. Check thermostat location. If on an outside wall, or there is a hole in the wall behind the thermostat, cold air may be coming in contact with the thermostat. Relocate.
	C. Defective thermostat.	C. Check thermostat calibration; verify thermostat temperature reading; or replace.

