

AMD Direct, Inc.

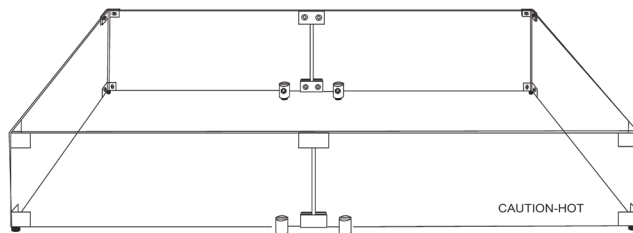
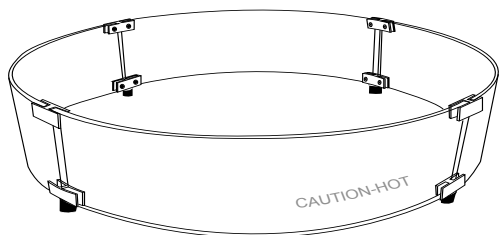

Round Models	Diameter	Width	Height
GSW-23R	23"	-	8"
GSW-32R	32"	-	8"
GSW-36R	36"	-	8"
GSW-38R	38"	-	8"
GSW-48R	48"	-	8"
GSW-60R	60"	-	8"
Square Models	Size	Width	Height
GWS-2424	24"	24"	8"
GWS-3030	30"	30"	8"
GWS-3838	38"	38"	8"
GWS-4242	42"	42"	8"

Rectangular Models	Length	Width	Height
GWS-2911	29 1/2"	11 1/2"	6"
GWS-3511	35 1/2"	11 1/2"	6"
GWS-4111	41 1/2"	11 1/2"	6"
GWS-5311	53 1/2"	11 1/2"	6"
GWS-6511	65 1/2"	11 1/2"	6"
GWS-7711	77 1/2"	11 1/2"	6"
GWS-2917	29"	17"	6"
GWS-3517	35"	17"	6"
GWS-4119	41"	19"	6"
GWS-5319	53"	19"	6"
GWS-6521	65"	21"	6"
GWS-7221	77"	21"	6"

Glass Windshields

Installation and Operating Instructions

These tempered glass windshields are designed for outdoor gas fire pits to protect the flame in high wind areas and provide a unique reflective flame appearance while flame is burning. In addition, they provide an attractive see-through addition to any fire pit.

**IF YOU CANNOT READ OR UNDERSTAND THESE INSTALLATION INSTRUCTIONS
DO NOT ATTEMPT TO INSTALL OR OPERATE A FIRE PIT**



WARNING:

- Hot glass will cause burns.
- Do not touch glass until cool.
- Never allow children to touch glass.
- Do not leave fire pit unattended during use.

CALIFORNIA PROPOSITION 65



WARNING

This product can expose you to Chromium, which is known to the state of California to cause cancer and birth-defects or other reproductive harm. (For more information, go to: www.p65warnings.ca.gov)

INSTALLATION FOR RECTANGULAR/SQUARE WINDSHIELDS

Tools Needed: Phillips screwdriver, soft leather gloves for handling glass, dry flat smooth surface large enough to accommodate the windshield for assembly.

CAUTION: It is recommended for two people to assemble the glass windshield. Lay the glass panels on a soft non-abrasive flat surface to keep windshield level.

CARTON CONENTS

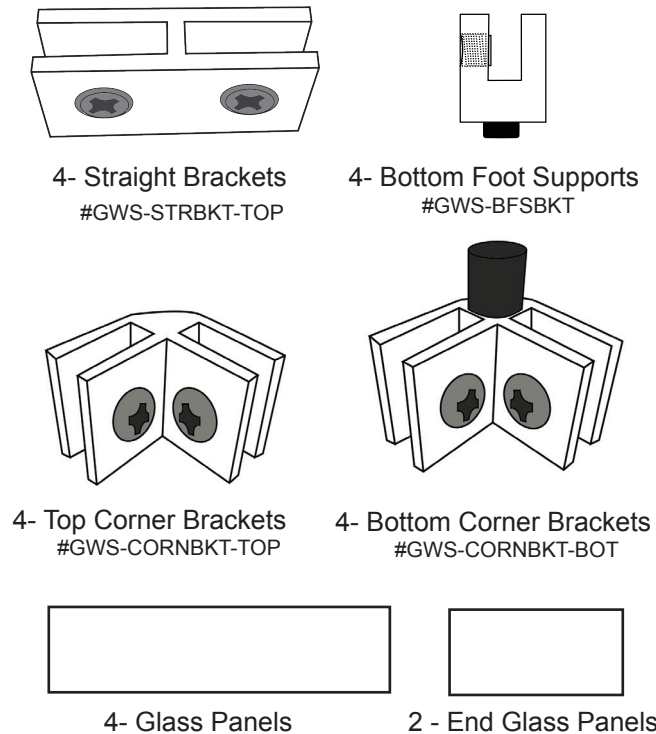

Fig. 1 Shows carton glass panels and rectangular windshield brackets.

BEFORE YOU BEGIN

Each bracket uses a nylon Phillips set-screw to secure the glass in place and to prevent glass breakage. Loosen the set screws in all brackets to allow glass to slip inside each bracket.

In most cases, assembly of the windshield will require more than one person to assist. This is because the windshield will require being turned upside down then inverted right side up for installation around the fire pit.

WARNING: Carefully secure the screws into position but do not overtighten. Warranty does not cover glass breakage during the assembly process.

CAUTION: THESE WINDSHIELDS ARE NOT DESIGNED FOR WOOD BURNING FIRE PITS. POTENTIAL GLASS BREAKAGE AND DAMAGE WILL OCCUR IF USED WITH A WOOD FIRE.

NOTE: This section covers both square and rectangular windshields. Review the assembly for a rectangular windshield then go directly to STEP 3, Fig. 4. to assemble a square windshield. Ensure the “CAUTION-HOT” sign is showing on at least one glass panel, facing outward. Use Fig. 5 for reference.

STEP 1: Begin by securing two long glass panels inside a straight bracket. Screw heads should be on the inside of the assembly and ensure the “CAUTION-HOT” sign is showing on at least one panel, facing outward. Each glass panel should slide all the way into the bracket and top edge should be flush with edge of glass. See Fig. 2.

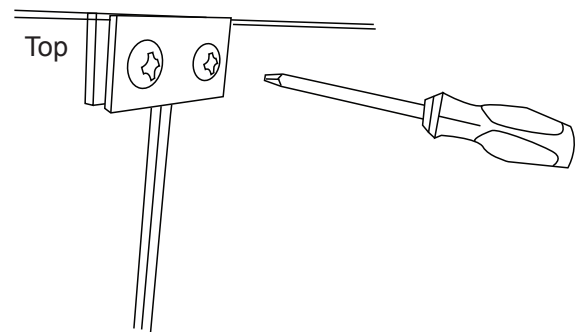

Fig. 2 Securing two long glass panels into the straight bracket.

STEP 2: Connect the two long glass panels at the bottom using another straight bracket in the same manner. Install two bottom foot supports approximately 1-inch away from the straight bracket. See Fig. 3.

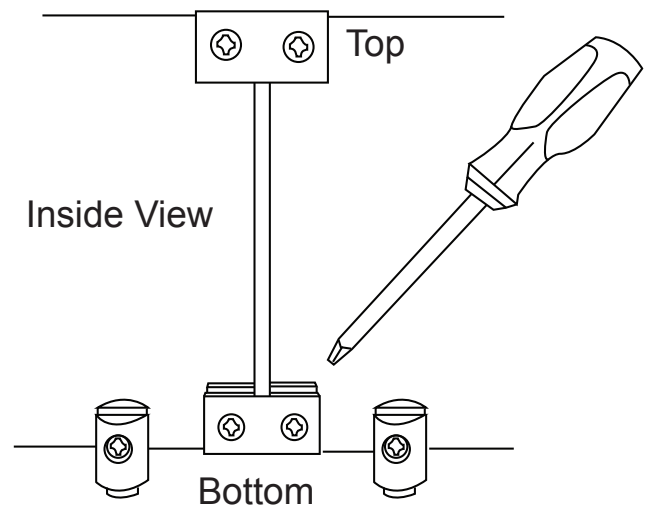

Fig. 3 Securing the straight bracket and two bottom foot supports with the Phillips screwdriver.

STEP 3: Connect end (short) glass panels using the corner brackets. Ensure the corner connector (with foot) is located at the bottom and the other corner connector (without foot) is connected at the top. See Fig. 4.

STEP 5: After all brackets are secured to the windshield carefully turnover the entire assembly, right-side up (black feet at the bottom) and place the windshield overtop of the fire pit centering around the burner pan it into place (See Fig. 6). Installation is now complete.

Double check the screws to ensure they did not come loose during installation to the fire pit.

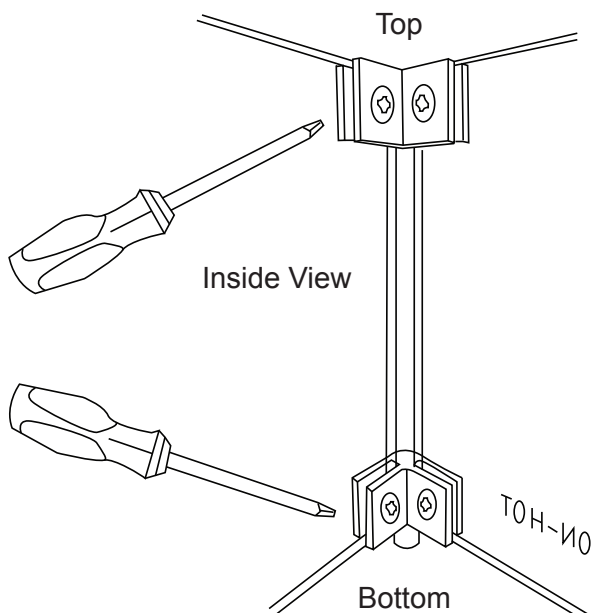

Fig. 4 Securing the corner brackets with a Phillips screwdriver.

STEP 4: Using one pair of connectors at a time, connect a single glass panel at either end using corner connectors to complete the assembly of the rectangle windshield. See Fig. 5. The short panels are the ends and the long panels are the sides. Ensure the bottom connectors (with foot) are located on the bottom.

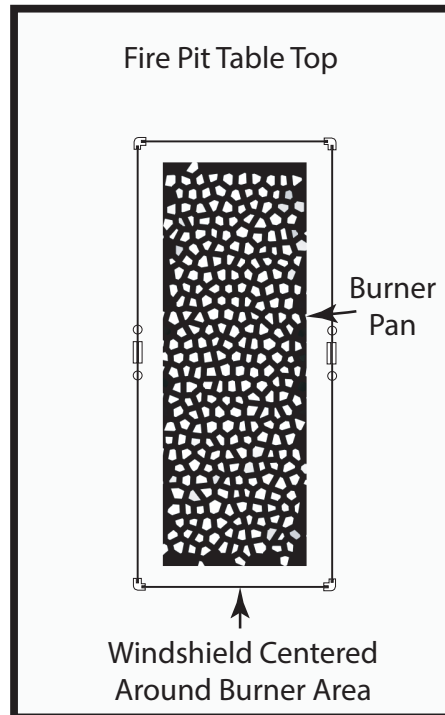

Fig. 6 Windshield installed (top view).

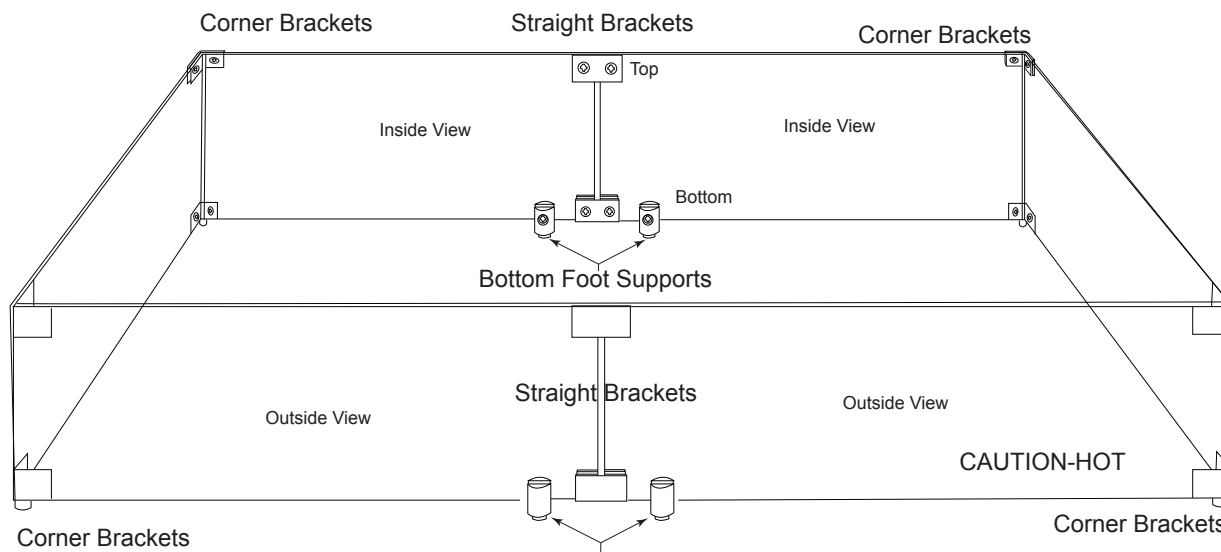

Fig. 5 Securing all brackets with a Phillips screwdriver.

INSTALLATION FOR ROUND WINDSHIELDS

Tools Needed: Phillips screwdriver, soft leather gloves for handling glass, dry flat smooth surface large enough to accommodate the windshield for assembly.

CAUTION: It is recommended for two people to assemble the glass windshield. Lay the glass panels on a soft non-abrasive flat surface to keep windshield level.

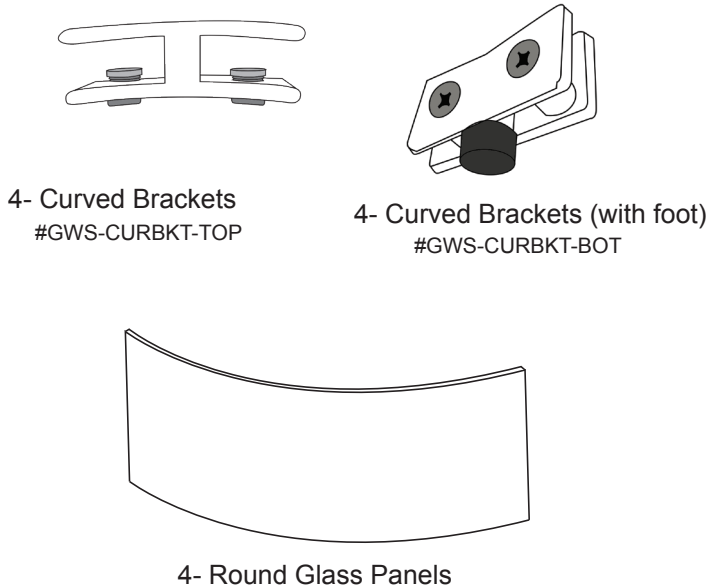

Fig. 6 Shows carton glass panels and rectangular windshield brackets.

STEP 1: Begin working from the bottom up by connecting two glass panels using the straight brackets and (with foot) and ensure the “CAUTION-HOT” sign is showing on at least one panel, facing outward. Each glass panel should slide all the way into the bracket and top edge should be flush with edge of glass. See Fig. 6.

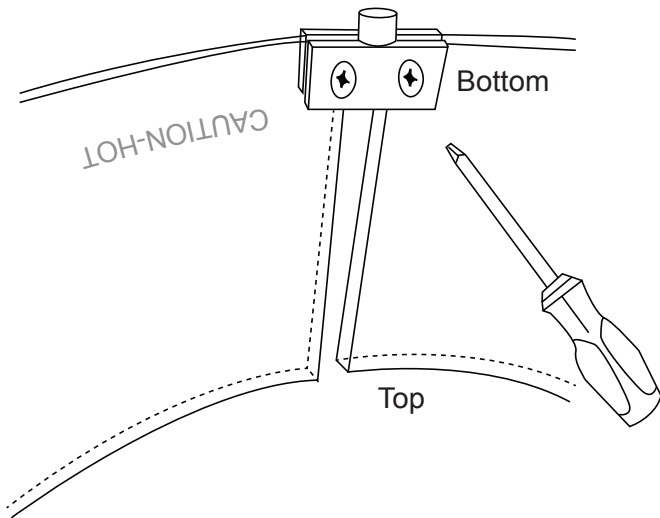

Fig. 7 Securing the brackets screws with a Phillips screwdriver.

STEP 1: Work your way around the glass panels. Keep the screws loose to ensure the brackets are positioned correctly with the glass panel all the way inside the bracket. See Fig. 8. Tighten only after all the brackets are properly in place. **Note:** Screw heads are to be positioned on the inside of the windshield.

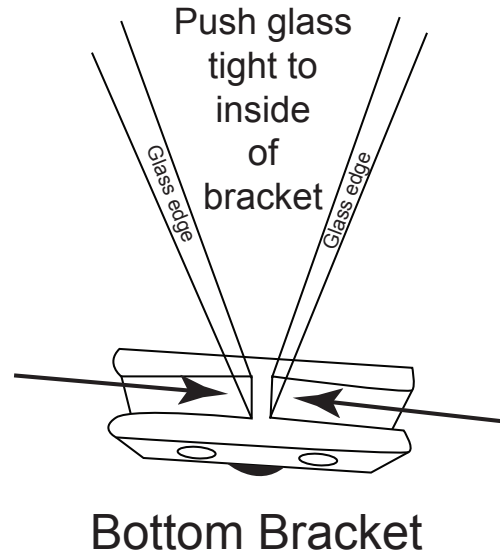

Fig. 8 Shows glass panel edge against inside of bracket.

STEP 3: Ensure all bracket screws are tightened as much as possible and are properly pressed against the glass. Slowly and carefully, flip the windshield over to the other side with the feet now touching the ground.

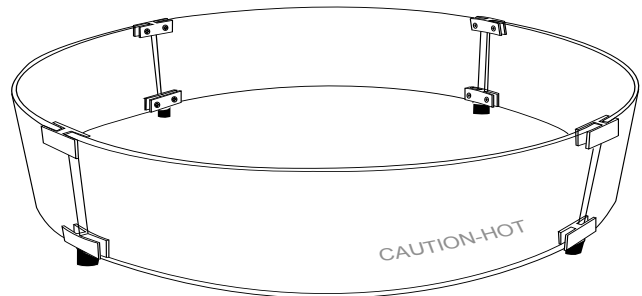

Fig. 9 Shows completed windshield upright and ready for installation over fire pit.

WARNING: Carefully secure the screws into position but do not overtighten. Warranty does not cover glass breakage during the assembly process.

STEP 4: Carefully place the windshield over-top of the fire pit centering around the burner into place (See Fig 10). Installation is now complete.

CAUTION: THESE WINDSHIELDS ARE NOT DESIGNED FOR WOOD BURNING FIRE PITS. POTENTIAL GLASS BREAKAGE AND DAMAGE WILL OCCUR IF USED WITH A WOOD FIRE.

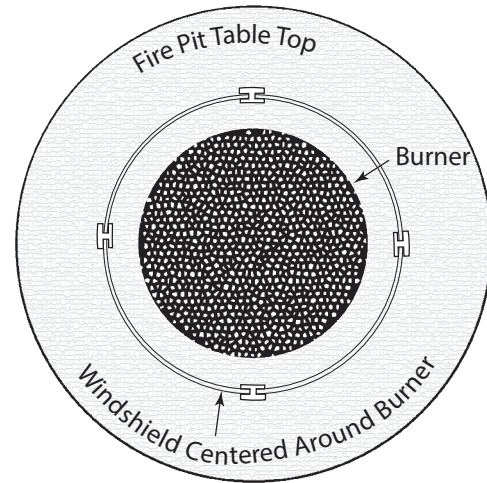

Fig. 10 Windshield installed.

FOR TECHNICAL SERVICE, CALL: (800) 966-8126

AMD Direct, Inc.
17322 Gothard St
Huntington Beach, CA 92647

Manual changes often occur, ensure to check the Firegear Outdoor website for any recent updates and warranty information.