

ASTORIA COLLECTION  
**MEDIA CONSOLE**

Item#: 63708

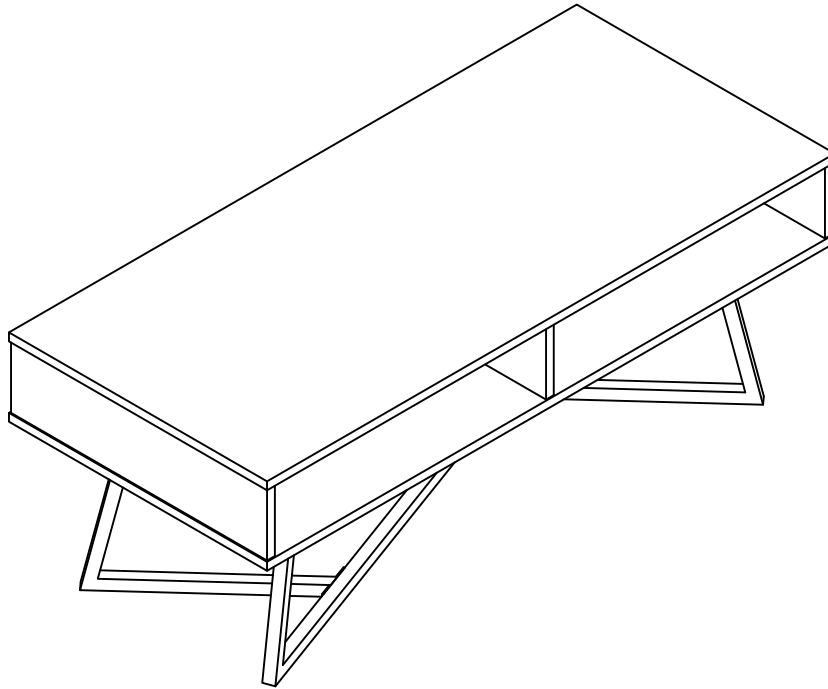

**ATTACH YOUR RECEIPT HERE**

Keep a copy of your proof of purchase or order confirmation which will be needed if you need to contact us about warranty coverage.

Purchase Date: \_\_\_\_\_



**SAVE THESE INSTRUCTIONS FOR FUTURE REFERENCE.**



**Questions, problems, missing parts?**

Before returning to your retailer, our Florida-based customer service team is available:

Call toll-free **(866) 985-7877** 9 a.m. – 9 p.m., EST  
Email **[cservice@welltraveled.net](mailto:cservice@welltraveled.net)**  
Live chat **[www.balkenehome.com](http://www.balkenehome.com)** 9 a.m. – 6 p.m., EST, Monday – Friday



## BEFORE YOU BEGIN

Before beginning assembly, make sure all parts are present. Compare parts received with the “Parts List.” If any part is missing or damaged, do NOT attempt to assemble the product. Please read and understand this entire manual before attempting to assemble, operate or install this product. If you have any questions regarding the product, please contact Customer Service:

Call toll-free	<b>(866) 985-7877</b>	9 a.m. – 9 p.m., EST
Email	<b><a href="mailto:cservice@welltraveled.net">cservice@welltraveled.net</a></b>	
Live chat	<b><a href="http://www.balkenehome.com">www.balkenehome.com</a></b>	9 a.m. – 6 p.m., EST, Monday – Friday



## GENERAL INFORMATION

This item is made of particleboard and a metal frame. For safe assembly, set up on a dry, soft, secure and clean surface. Do not clean with detergent or chemicals. Do not sit or stand on the unit. Do not place hot items such as coffee cups directly on the surface of this item. Keep away from direct sunlight and water. Do not drag the unit. For indoor use only.



## SAFETY INFORMATION

### **WARNING**

DO NOT sit or stand or allow children to sit or stand on the assembled product. Make sure connectors are securely in place. Perform periodic checks to make sure the connectors are secure and adjust if needed. Keep unassembled parts and hardware away from children and infants. This package contains small parts and sharp points. Adult assembly required.

### **CAUTION**

READ all instructions before beginning assembly. Failure to do so may result in faulty assembly and potential injury. Assemble the item on a soft, non-abrasive surface such as carpet or cardboard to avoid damaging the item.

Max safe load limit: 25 KG / 55 LB.

# PARTS LIST

# BALKENE —HOME—

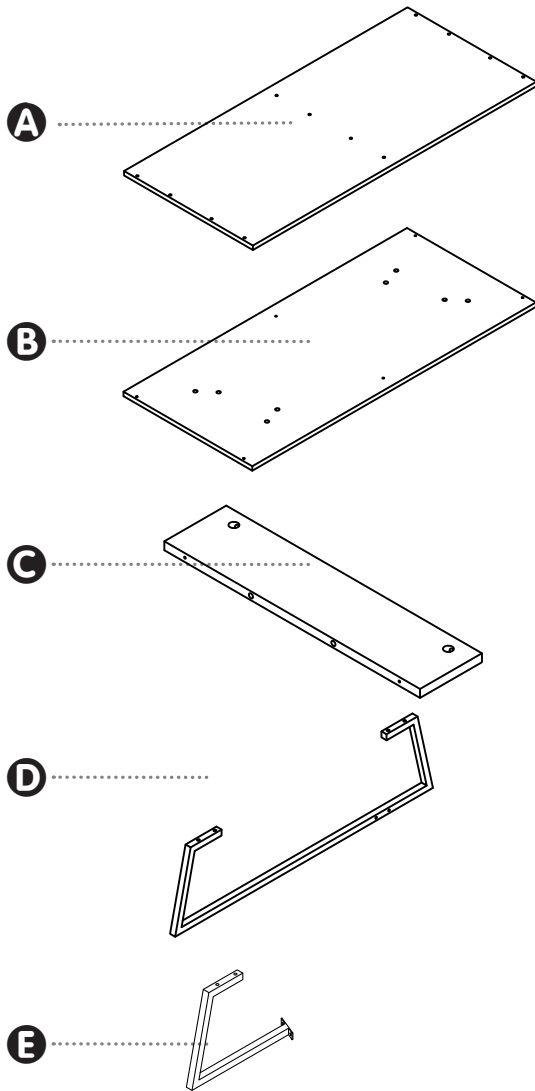

PART	DESCRIPTION	QUANTITY
<b>A</b>	Top	1
<b>B</b>	Bottom	1
<b>C</b>	Vertical Panel	3
<b>D</b>	Long Leg	1
<b>E</b>	Short Leg	2



## HARDWARE CONTENTS

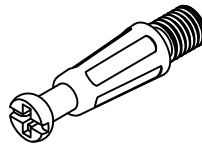

**F**  
Cam Bolt  
Qty: 6



**G**  
Cam Lock Nut  
Qty: 6

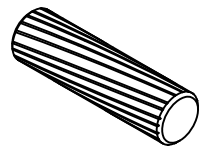

**H**  
Wood Dowel  
Qty: 12

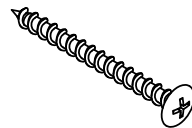

**I**  
Screw M4x40mm  
Qty: 6

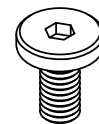

**J**  
Bolt M6x12mm  
Qty: 4

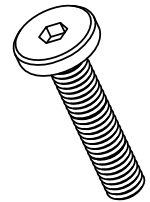

**K**  
Bolt M6x30mm  
Qty: 8

## PREPARATION

Before beginning assembly, be sure to empty contents of carton and make sure all parts are present. If any parts are missing, please contact Customer Service.

Place all parts on a soft, level surface for assembly.  
Estimated Assembly Time: 30 Minutes

DO NOT over-tighten hardware!

## YOU WILL NEED FOR ASSEMBLY:

*(not included)*

### Rubber Mallet

*(If none is available, use a hammer, but add padding as necessary to protect parts and surfaces.)*

### Phillips-head Screwdriver

# ASSEMBLY

# BALKENE —HOME—

**1** Turn the **Top** **A** upside-down on a soft, nonabrasive surface. Insert the threaded ends of the **Cam Bolts** **F** into the 4 holes near each corner of the **Top** and the 2 holes closest to the middle of each long side.

Insert **Wood Dowels** **H** into the holes in the long edges of each of the 3 **Vertical Panels** **C**. Use the rubber mallet to seat them securely.

**Hardware Used:** **F** Cam Bolt x 6  
**H** Dowel x 12

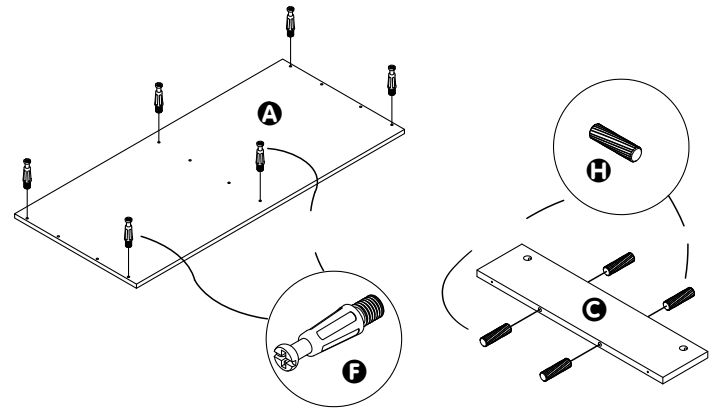

**2** Insert a **Cam Lock Nut** **G** into the larger holes at 2 corners of each **Vertical Panel**, then use a Philips-head screwdriver to rotate the **Cam Lock Nut** so the small arrow points toward the adjacent hole on the edge of the panel.

Attach the **Vertical Panels** to the **Top** by sliding the edge with the **Cam Lock Nuts** down onto the previously-installed **Cam Bolts**. Use the Philips-head screwdriver to rotate each **Cam Lock Nut** clockwise until it catches the **Cam Bolt** securely.

**Hardware Used:** **G** Cam Lock Nut x 6

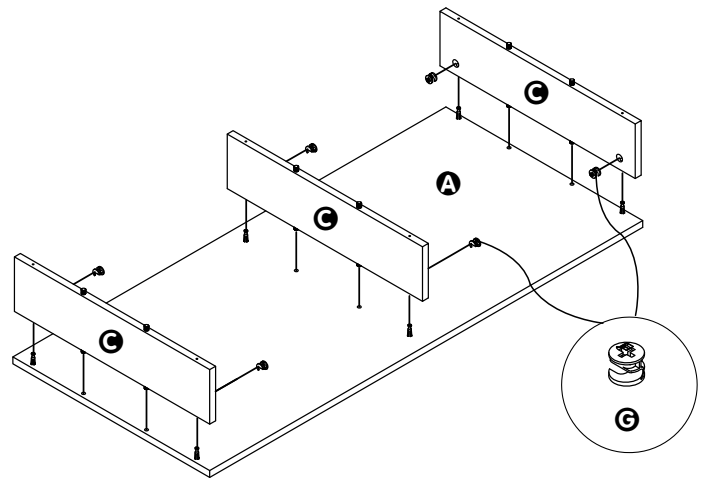

**3** Install the **Bottom** **B** by aligning the 6 dowel holes in its top surface (facing down for install) with the **Wood Dowels** in the edges of the **Vertical Panels**.

Secure using 6 **Screws** **I** near each corner as shown.

**Hardware Used:** **I** Screw (M4x40) x 6

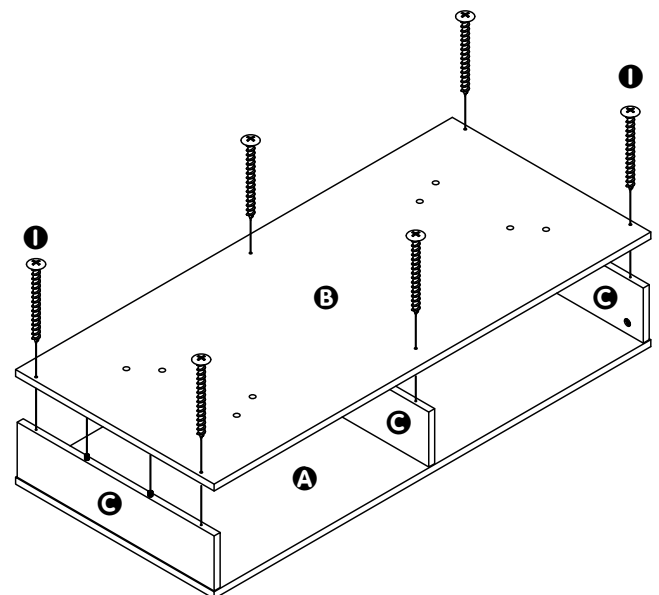

# ASSEMBLY

# BALKENE —HOME—

**4** Attach the **Short Legs E** to the **Long Leg D** using 4 small **Bolts J** as shown. Partially tighten, but do not fully tighten **Bolts** until the unit is upright and checked for levelness.

Hardware Used: **J Bolt (M6x12) x 4**

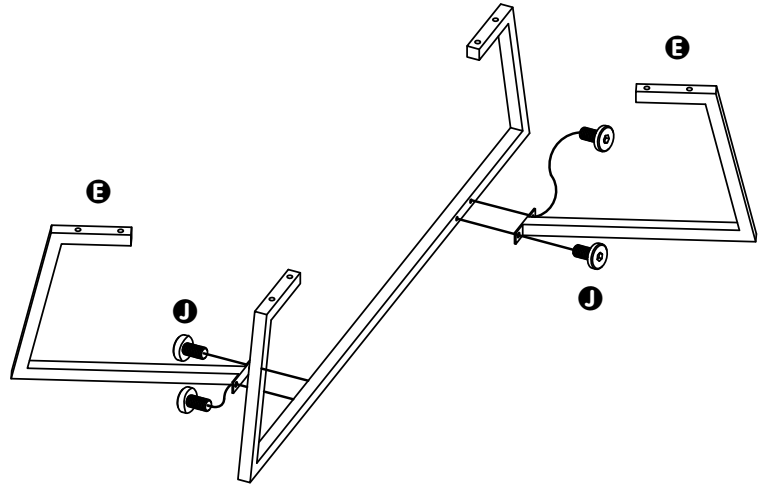

**5** Install the assembled base using 8 large **Bolts K** as shown. Partially tighten all **Bolts** using the included hex wrench.

Hardware Used: **K Bolt (M6x30) x 8**

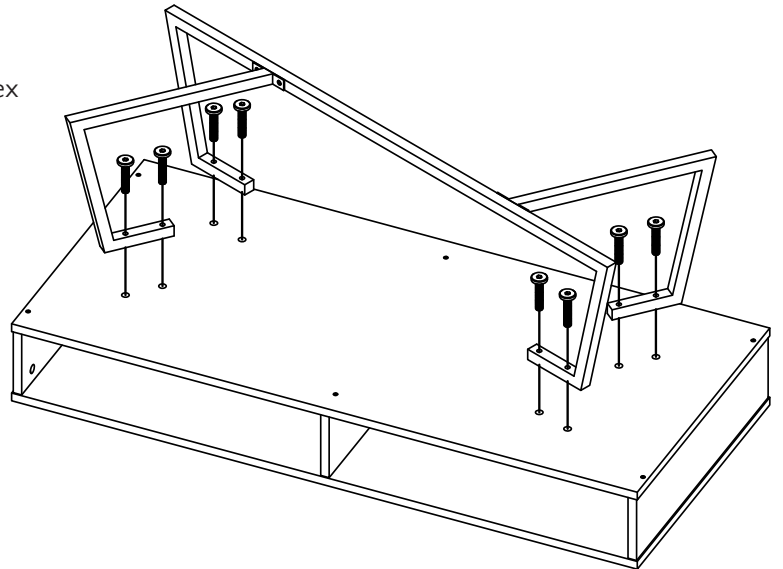

**6** Carefully turn the assembled unit upright. Adjust the alignment of the base, if necessary, until the **Legs** sit level on the floor, then tighten all **Bolts J/K** using the included hex wrench.

Your **Astoria Media Console** is ready for use!

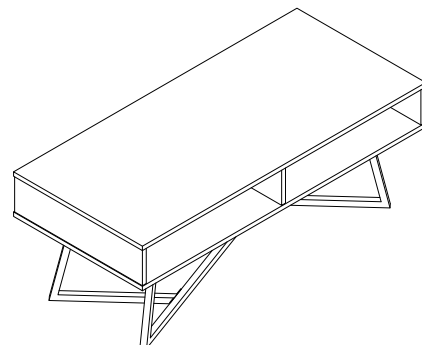



## LIMITED WARRANTY

Customers in the Contiguous US

With proof of purchase from an authorized retailer, this product is warranted for a period of 1 year from original purchase date against defects in materials and workmanship under normal use. This warranty does NOT cover normal wear/weathering, exposure to water, freezing temperatures, oils, fluids, or chemicals OR use in a commercial context if the unit is not designated as a commercial model. At Well Traveled Living's sole discretion, products under warranty will be repaired and/or replaced at no charge to the customer. Returns sent back to Well Traveled Living must be sent via prepaid freight in the original retail packaging.

For warranty service, contact Balkene Home/Well Traveled Living at the address, phone numbers or website and email listed in this owner's manual. Be sure to have your sales receipt, date of purchase and catalogue/model numbers available when calling. All warranty service will be coordinated by Well Traveled Living's Amelia Island, Florida service center. This warranty is extended only to the original owner. Proof of purchase will be required before warranty service is rendered. The sales receipt is the only valid proof of purchase. This warranty only covers failures due to defects in materials or workmanship which occur during normal use. Failures and/or damage which result from accident, negligence, misuse, abuse, neglect, mishandling, alteration or modification, failure to maintain, improper assembly or maintenance, service by unauthorized agency or use of unauthorized components or damage that is attributable to acts of God are NOT covered.

This limited warranty gives you specific legal rights and you may also have other rights which vary from jurisdiction to jurisdiction. The provisions of the United Nations Convention on Contracts for the Sales of Goods shall not apply to this limited warranty or the sale of products covered by this limited warranty.

- THERE ARE NO EXPRESS WARRANTIES EXCEPT AS LISTED.
- PURCHASER ASSUMES ALL RISKS IN THE ASSEMBLY AND OPERATION OF THIS UNIT.
- FAILURE TO FOLLOW WARNINGS AND OPERATIONAL INSTRUCTIONS CONTAINED IN THIS MANUAL CAN RESULT IN SEVERE PROPERTY DAMAGE AND/OR PERSONAL INJURY.
- IN NO EVENT WILL WELL TRAVELED LIVING, OR ITS DIRECTORS, OFFICERS OR AGENTS BE LIABLE TO THE PURCHASER OR ANY THIRD PARTY, WHETHER IN CONTRACT, IN TORT, OR ON ANY OTHER BASIS, FOR ANY INDIRECT, SPECIAL, PUNITIVE, EXEMPLARY, CONSEQUENTIAL, OR INCIDENTAL LOSS, COST, OR DAMAGE ARISING OUT OF OR IN CONNECTION WITH THE SALE, MAINTENANCE, USE, OR INABILITY TO USE THE PRODUCT, EVEN IF WELL TRAVELED LIVING OR ITS DIRECTORS, OFFICERS OR AGENTS HAVE BEEN ADVISED OF THE POSSIBILITY OF SUCH LOSSES, COSTS OR DAMAGES, OR IF SUCH LOSSES, COSTS, OR DAMAGES ARE FORESEEABLE. IN NO EVENT WILL WELL TRAVELED LIVING, OR ITS OFFICERS, DIRECTORS, OR AGENTS BE LIABLE FOR ANY DIRECT LOSSES, COSTS OR DAMAGES THAT EXCEED THE PURCHASE PRICE OF THE PRODUCT.
- SOME JURISDICTIONS DO NOT ALLOW THE EXCLUSION OR LIMITATION OF INCIDENTAL OR CONSEQUENTIAL DAMAGES, SO THE ABOVE LIMITATION OR EXCLUSION MAY NOT APPLY TO THE PURCHASER.

## EXTEND YOUR WARRANTY

When you purchase a Fire Sense or Balkene Home product from any authorized retailer, you'll have peace of mind in knowing that it comes with a one-year warranty. Extend your warranty for *an additional year* when you review your item at [balkenehome.com](http://balkenehome.com) within 365 days of purchase.



### Important Notice

Do NOT return to place of purchase—for customer service and warranty issues:

Call toll-free  
Email  
Live chat

**(866) 985-7877**  
**[cservice@welltraveled.net](mailto:cservice@welltraveled.net)**  
**[balkenehome.com](http://balkenehome.com)**

9 am – 9 pm, EST  
9 am – 6 pm, EST, Mon – Fri

Distributed by:

Well Traveled Living  
716 S 8th Street, Amelia Island, FL 32034  
[balkenehome.com](http://balkenehome.com)  
[cservice@welltraveled.net](mailto:cservice@welltraveled.net)  
(866) 985-7877