

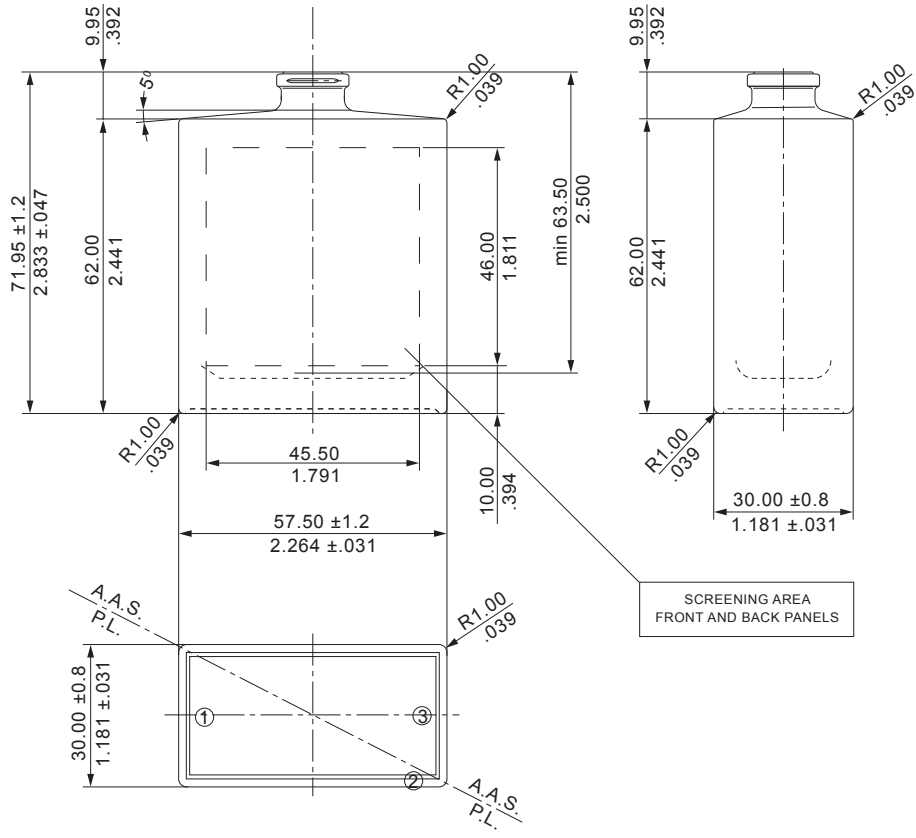

1	TRADE MARK
2	STIPPLE BEARING SURFACE
3	CAVITY N°

FINISH DETAIL SCALE 5:1

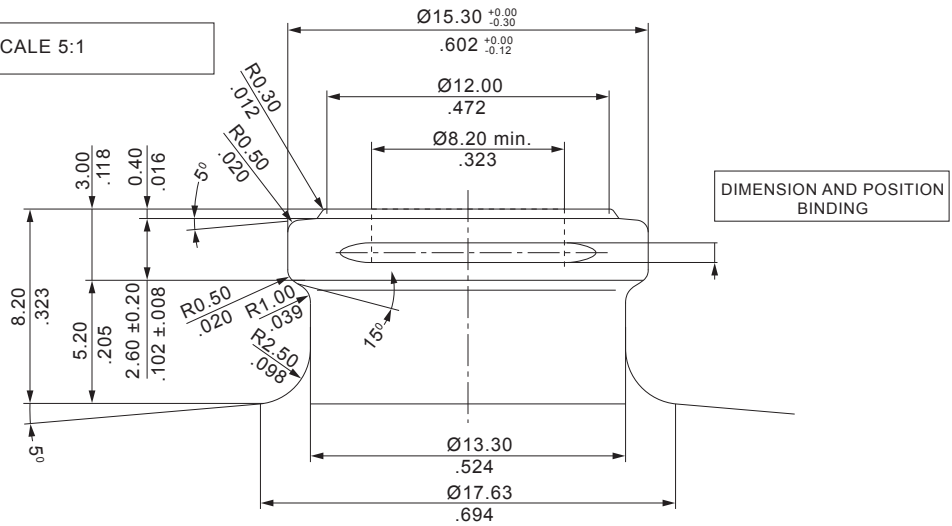

ITEM	DAVID FLINT BOTTLE 50ML 15MM			 NEW HIGH GLASS INC. 12713 SW 125TH AVE. MIAMI, FL 33186 305 - 232 - 0840
FINISH	FEA 15	WEIGHT	125 g	
OVERFLOW CAPACITY	RB 56.5 ± 3 cc	SCALA	NO SCALE	
THIS PRINT IS PROPERTY OF NEW HIGH GLASS INC. IT MUST NOT BE REPRODUCED OR INFORMATION HEREIN TRANSMITTED IN ANY WAY WITHOUT THE WRITTEN CONSENT OF NEW HIGH GLASS INC.	DATE	8/26/2021		