



Rolling Outrigger Beam, 5x5

Instruction Manual



920514
16 ft Rolling
Outrigger



920524
24 ft Rolling Outrigger



920527
24 ft Rolling Outrigger
with Cable Truss



920528
24 ft Rolling Outrigger
with 8 ft Splice Tube

Description

Versatile! The Rolling Outrigger Beam System is based around the strong aluminum 5x5 H-beam, allowing versatility in beam lengths and outreaches. Many accessories are available to solve almost any rigging challenge.

The standard Rolling Outrigger packages will clear a 6 ft parapet wall and allow outreaches up to 8 ft. The Caster Dollies mount on top of 5 ft wide scaffold frames for unlimited height clearance. Many configurations are possible with outreaches up to 14 ft.

Specifications

Part No.:

- 920514 Rolling Outrigger, 5x5 16 ft LCJ
- 920524 Rolling Outrigger, 5x5 24 ft LCJ
- 950527 Rolling Outrigger, 5x5 24 ft LLCJT
- 950528 Rolling Outrigger, 5x5 24 ft LLCJ8

Load Capacity: 750 to 1500 lb

Outreach: 5 ft w/o truss, 7 ft w/truss, 8 ft w/8 ft splice tube

Dimensions: 44-72"x60"x16-24' (HxWxL)

Weight: 418, 489, 521 and 550 lb



GENERAL WARNING - Read First

**Safety is a matter of life or death for riggers, operators and by-standers.
This warning is your share of duties for achieving safety.**

Your duty to understand and comply:

1. It is imperative for safety and efficiency of operations that this manual be read and fully understood by the rigger and the operator before rigging and using this equipment. All instructions contained herein must be carefully and strictly followed, including applicable Bee Access guidelines.
2. Should you hand over this equipment under any conditions, to any party operating out of your control, you must attach a clean copy of this manual and draw to other party's attention that strictly following all the instructions therein is a matter of life or death.
3. Before using this equipment, the rigger and the operator must become aware of all requirements of federal, state, provincial and local safety regulations, applicable to the entire suspended scaffold system and any component of it.
4. Never load this equipment above its rated load of **1500 lbs.**
5. Bee Access declines any responsibility for any special layouts, rigging or structural combinations beyond the descriptions of this manual.
6. Bee Access declines any responsibility for any other use of this equipment, than described in this manual.

Your duty to inspect and maintain:

7. Keep this manual available at all times for easy reference whenever required. Extra copies are available from Bee Access and/or your equipment supplier.
8. Carefully take notice of all labels affixed to the equipment. Never rig or operate this equipment if any label, normally fixed on it is obscured or missing. Replacement labels are available from Bee Access and/or your equipment supplier.
9. Every time the suspended scaffold is to be rigged or used, check that the Tieback Anchor, rigging, hoists, platform and other components are complete and in good working condition, prior to proceeding. All wire ropes and safety lines and their protective sleeves should be inspected at the beginning of every shift. Check for wear and abrasion due to contact with rigging equipment and/or the building structure.
- 10. Inspection is to be carried out by personnel authorized by Bee Access once every 12 months.** Thoroughly check overall condition for bent, damaged or worn parts and broken welds. A signed and dated inspection record should be maintained for these purposes.
11. Make sure to comply with inspection and maintenance guidelines of all other components used in the suspended scaffold system.
12. Bee Access declines any responsibility for consequences of repairs or modifications brought out of its control to the product, specifically by replacement of original parts or repairs by another manufacturer.

Your duty to train and control people:

Compliance with safety rules extends to rigging operations which must be carried out only after securing safe conditions of operation as per safety regulations and requirements.

13. An operator must not be assigned to rigging, de-rigging, moving or operating a suspended scaffold if that person is not:
 - a. Mentally and physically fit for the purpose, especially at heights
 - b. Competent for the job to be performed
 - c. Familiar with the scaffold equipment as rigged
 - d. Professionally trained for working under the above requirements
14. Never let the equipment be moved or operated by unauthorized personnel. Keep the equipment, either rigged or unrigged, out of reach of unauthorized persons, while out of operation.
15. Every suspended job must be placed under the control of a person having the required competence and authority for checking that all the instructions prescribed by this manual be regularly and efficiently carried out.

Your duty to safety of the entire scaffold system:

A suspended scaffold system is made up of numerous pieces of equipment; all of these components can contribute to the required safety only if:

16. Other components meet the requirements of the applicable safety regulations and requirements, are of the proper quality, assembled to form a safe and efficient suspended system and compatibility is approved by Bee Access.
17. The supporting structure and tie-backs can withstand every load to be applied, either static or dynamic, during rigging or operating of the suspended scaffold equipment.
18. All the requirements in strength and resistance are obtained with the necessary safety coefficients (call your supplier for regulations and professional standards).
19. All the calculations, design and subsequent work necessary to meet the above requirements have been made by a competent person on the basis of proper technical information regarding the site.

NOTE: This manual is neither a regulations compliance manual nor a general training guide on suspended scaffold operations. You must refer to proper instructions delivered by your supplier of the other pieces of equipment included in your suspended scaffold installation. Whenever calculations and specific rigging and handling are involved, the operator should be professionally trained to that end and secure relevant information prior to commencing such work.

Read and comply with the "Code of Safe Practices for Suspended Powered Scaffolds" issued by the Scaffold & Access Industry Association (available from your supplier).



Rolling Outrigger Beam, 5x5

Parts List

920514 - Rolling Outrigger, 16 ft LCJ

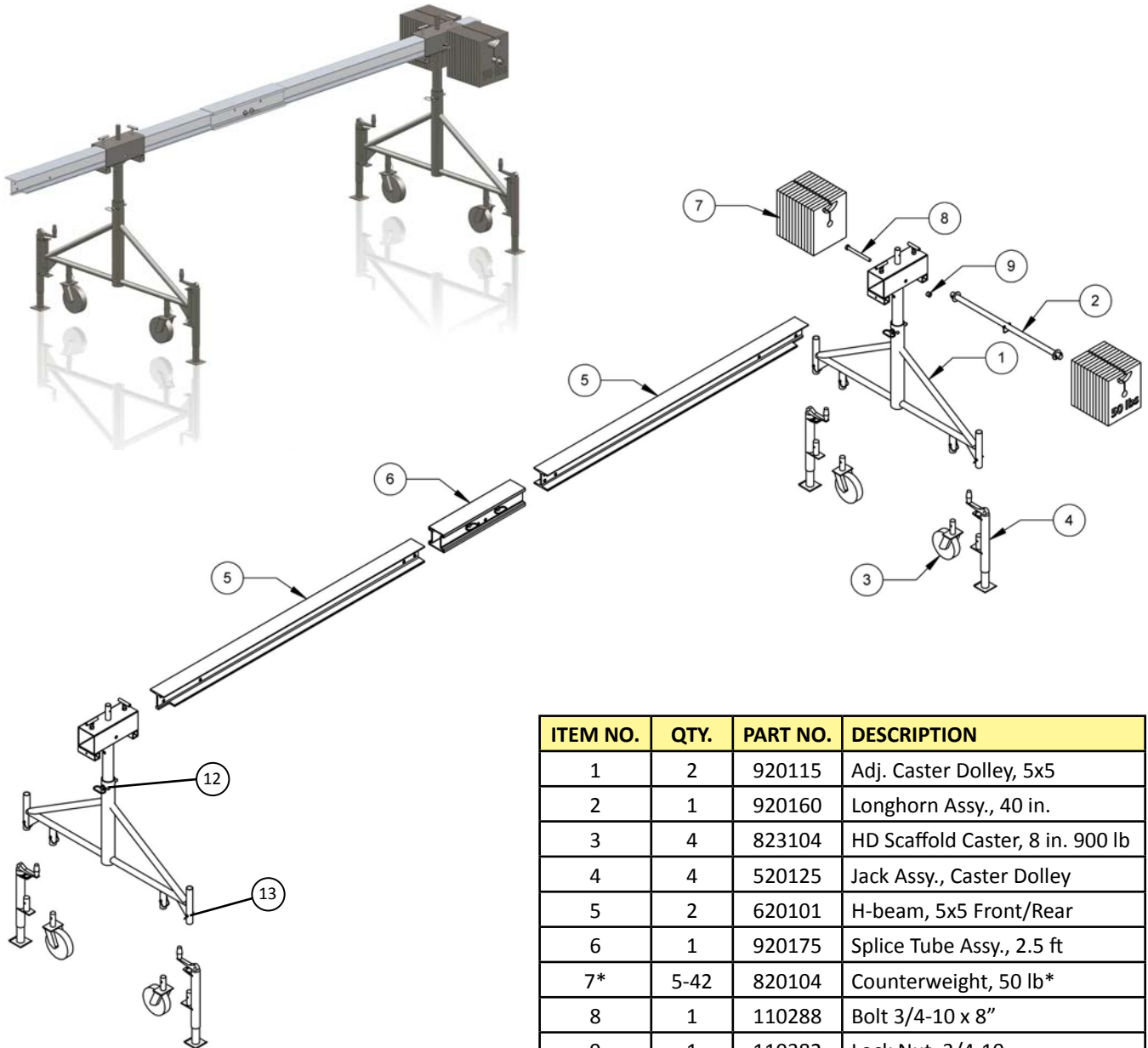

ITEM NO.	QTY.	PART NO.	DESCRIPTION
1	2	920115	Adj. Caster Dolley, 5x5
2	1	920160	Longhorn Assy., 40 in.
3	4	823104	HD Scaffold Caster, 8 in. 900 lb
4	4	520125	Jack Assy., Caster Dolley
5	2	620101	H-beam, 5x5 Front/Rear
6	1	920175	Splice Tube Assy., 2.5 ft
7*	5-42	820104	Counterweight, 50 lb*
8	1	110288	Bolt 3/4-10 x 8"
9	1	110382	Lock Nut, 3/4-10
12	2	110110	Hitch Pin, 3/4x4.5 in.
13	8	110103	Hitch Pin, 5/16x2.25 in.

* Optional, not part of the package



Rolling Outrigger Beam, 5x5

Parts List

920524 - Rolling Outrigger, 24 ft LCJ

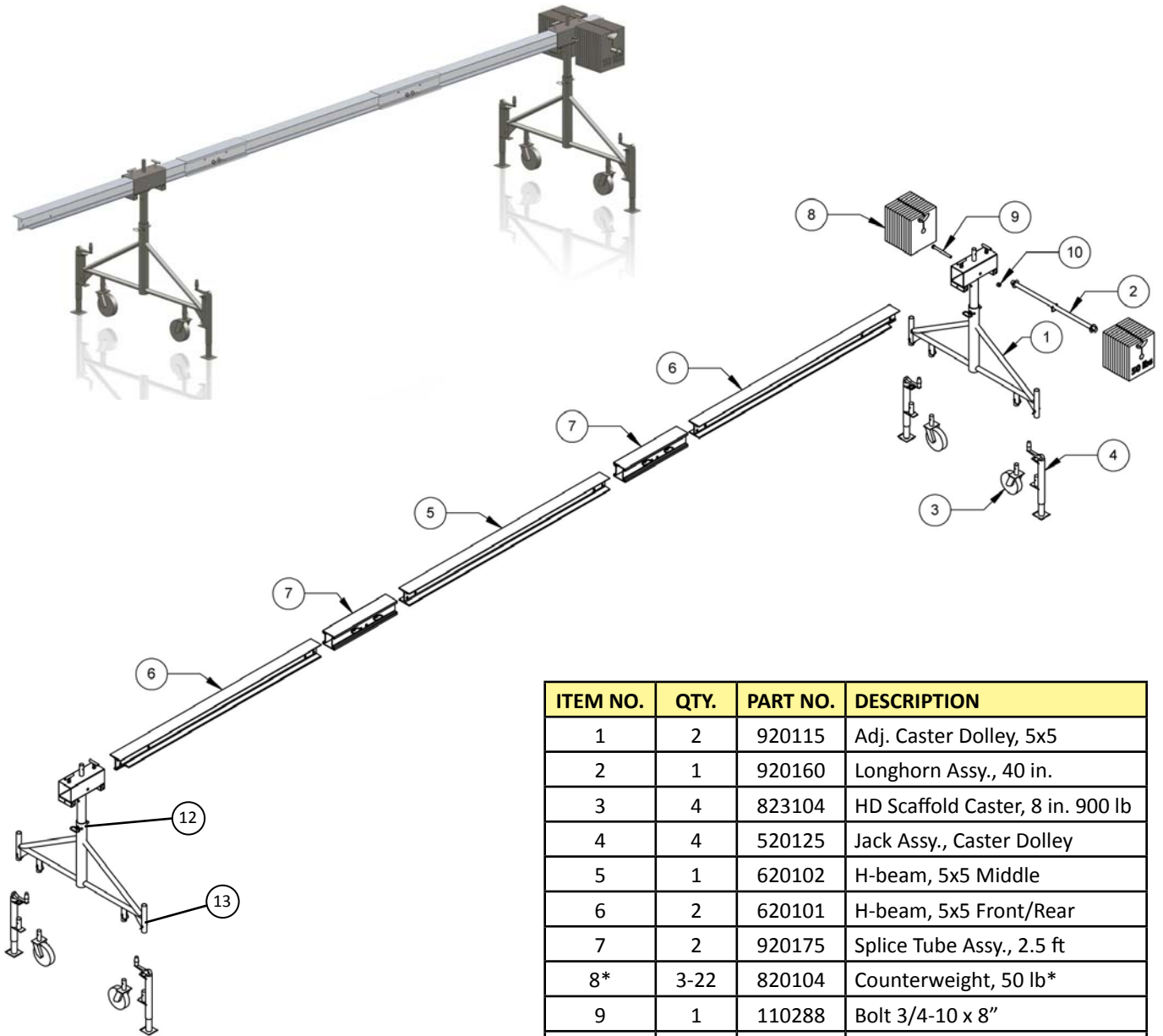

ITEM NO.	QTY.	PART NO.	DESCRIPTION
1	2	920115	Adj. Caster Dolley, 5x5
2	1	920160	Longhorn Assy., 40 in.
3	4	823104	HD Scaffold Caster, 8 in. 900 lb
4	4	520125	Jack Assy., Caster Dolley
5	1	620102	H-beam, 5x5 Middle
6	2	620101	H-beam, 5x5 Front/Rear
7	2	920175	Splice Tube Assy., 2.5 ft
8*	3-22	820104	Counterweight, 50 lb*
9	1	110288	Bolt 3/4-10 x 8"
10	1	110382	Lock Nut, 3/4-10
12	2	110110	Hitch Pin, 3/4x4.5 in.
13	8	110103	Hitch Pin, 5/16x2.25 in.

* Optional, not part of the package



Rolling Outrigger Beam, 5x5

Parts List

920527 - Rolling Outrigger, 24 ft LLCJT

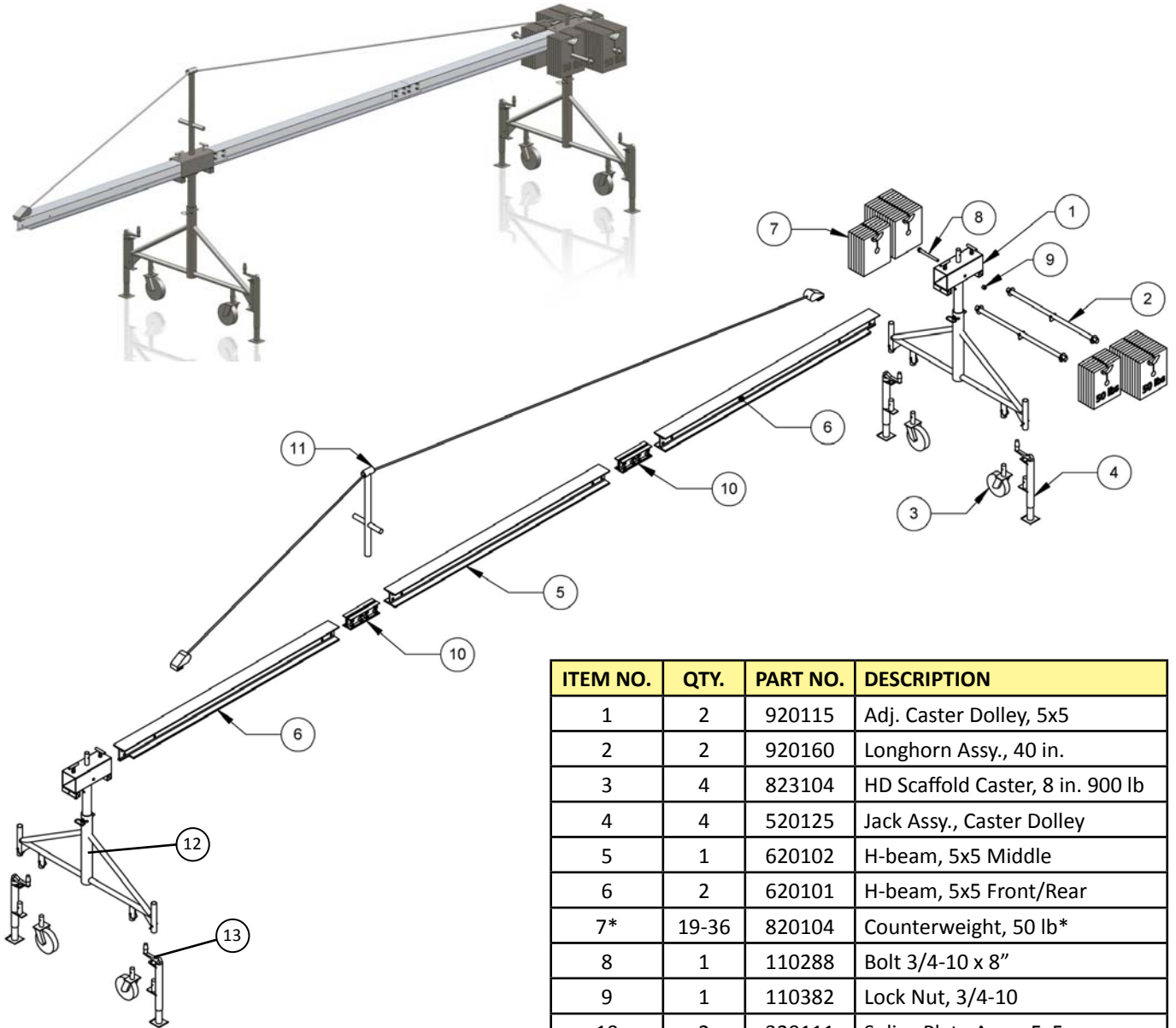

ITEM NO.	QTY.	PART NO.	DESCRIPTION
1	2	920115	Adj. Caster Dolley, 5x5
2	2	920160	Longhorn Assy., 40 in.
3	4	823104	HD Scaffold Caster, 8 in. 900 lb
4	4	520125	Jack Assy., Caster Dolley
5	1	620102	H-beam, 5x5 Middle
6	2	620101	H-beam, 5x5 Front/Rear
7*	19-36	820104	Counterweight, 50 lb*
8	1	110288	Bolt 3/4-10 x 8"
9	1	110382	Lock Nut, 3/4-10
10	2	320111	Splice Plate Assy., 5x5
11	1	320105	24 ft Cable Truss Assy.
12	2	110110	Hitch Pin, 3/4x4.5 in.
13	8	110103	Hitch Pin, 5/16x2.25 in.

* Optional, not part of the package



Rolling Outrigger Beam, 5x5

Parts List

920528 - Rolling Outrigger, 24 ft LLCJ8

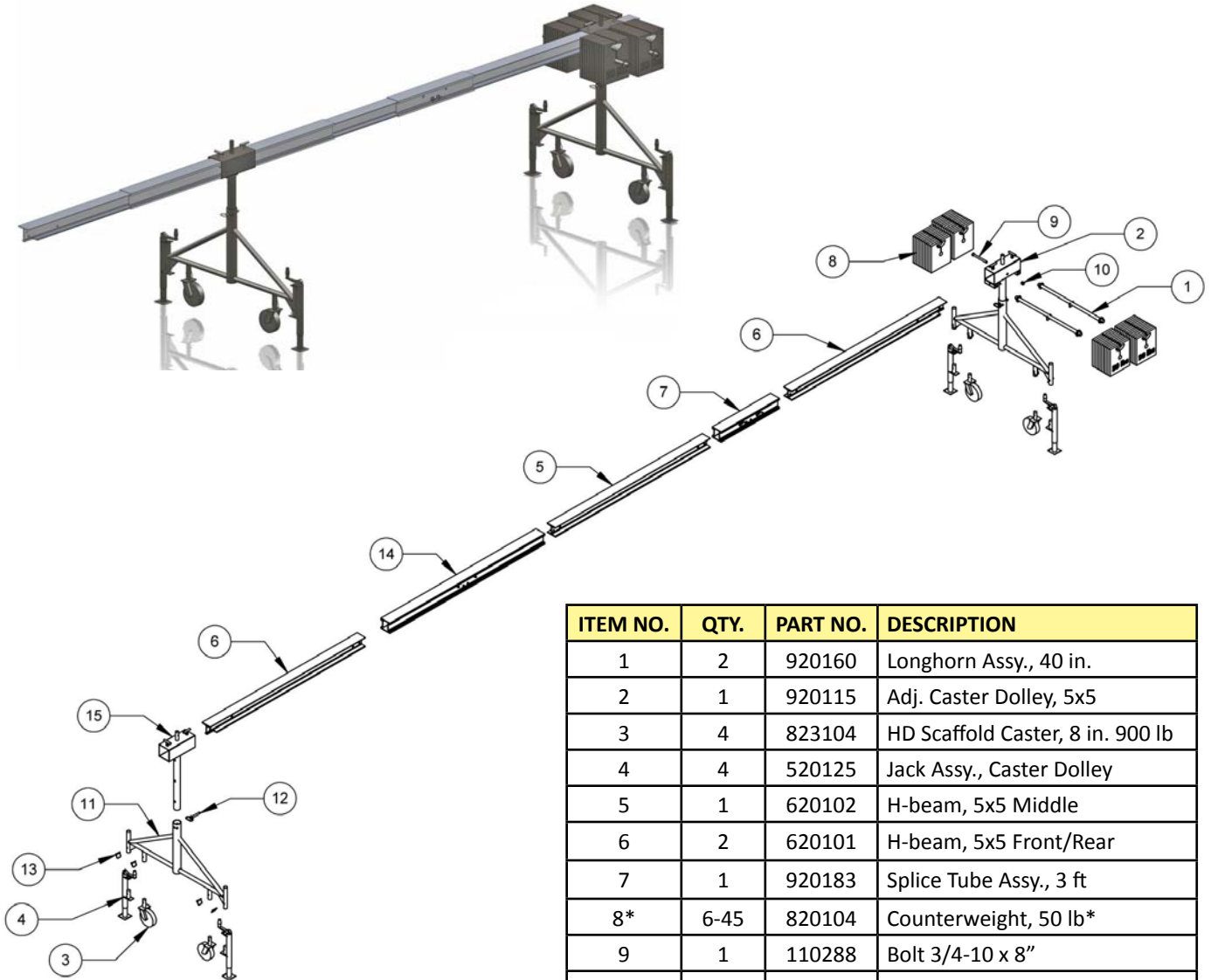

ITEM NO.	QTY.	PART NO.	DESCRIPTION
1	2	920160	Longhorn Assy., 40 in.
2	1	920115	Adj. Caster Dolley, 5x5
3	4	823104	HD Scaffold Caster, 8 in. 900 lb
4	4	520125	Jack Assy., Caster Dolley
5	1	620102	H-beam, 5x5 Middle
6	2	620101	H-beam, 5x5 Front/Rear
7	1	920183	Splice Tube Assy., 3 ft
8*	6-45	820104	Counterweight, 50 lb*
9	1	110288	Bolt 3/4-10 x 8"
10	1	110382	Lock Nut, 3/4-10
11	1	520112	Base, Adj. Caster Dolley
12	2	110110	Hitch Pin, 3/4x4.5 in.
13	8	110103	Hitch Pin, 5/16x2.25 in.
14	1	920176	Splice Tube Assy., 8 ft
15	1	920205	Masthead for 5x5 Splice Tube

* Optional, not part of the package



Rolling Outrigger Beam, 5x5

Beam Accessories

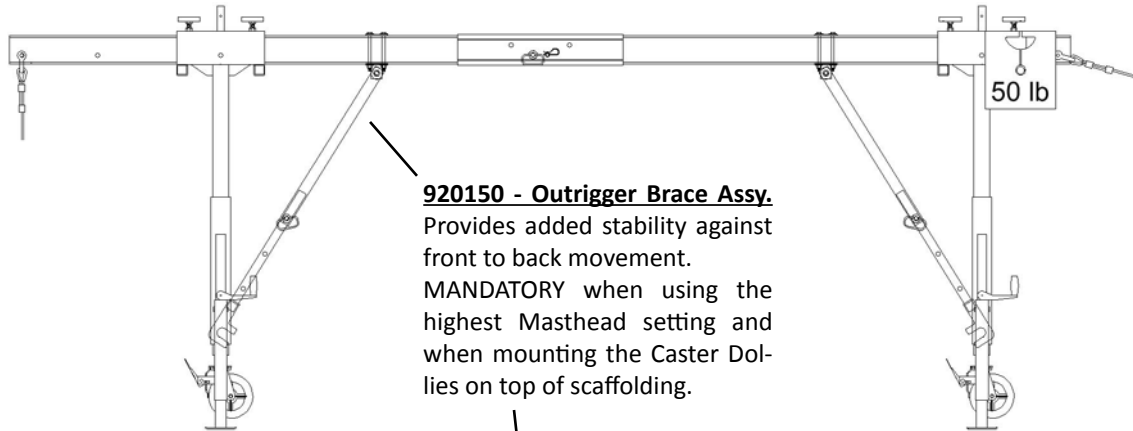

Caster Dollies can be mounted on 5 ft wide scaffold frames to clear tall parapets.

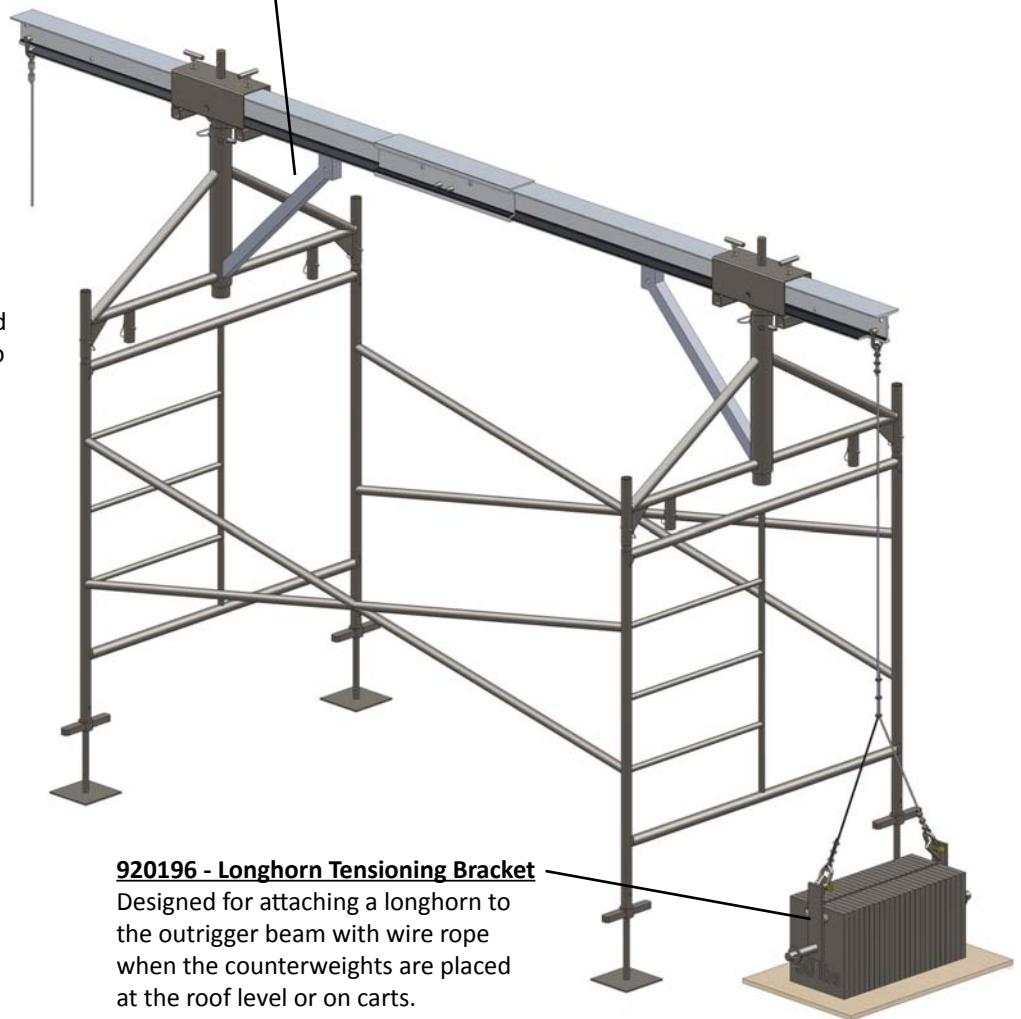



Rolling Outrigger Beam, 5x5

Beam Accessories



920184 - EZ Down&Under Assy., 5x5

Max. 9 ft down and 4 ft back under.
Longer down tubes and under beams also available.

920307 - Flat Free Caster Assy., 12" with brake



921102 - Beam Clamp, Coiled Rod

Use 2 per splice connection. Angle the clamps to let the threaded rods be positioned against the beam to prevent bending the flat bars

921105 - Double Beam Clamp, 5x5

For use with double stacked beams. Use at the front and on the first splice behind the fulcrum point on out-reaches over 10 ft for added strength and help prevent the beam from rolling over.

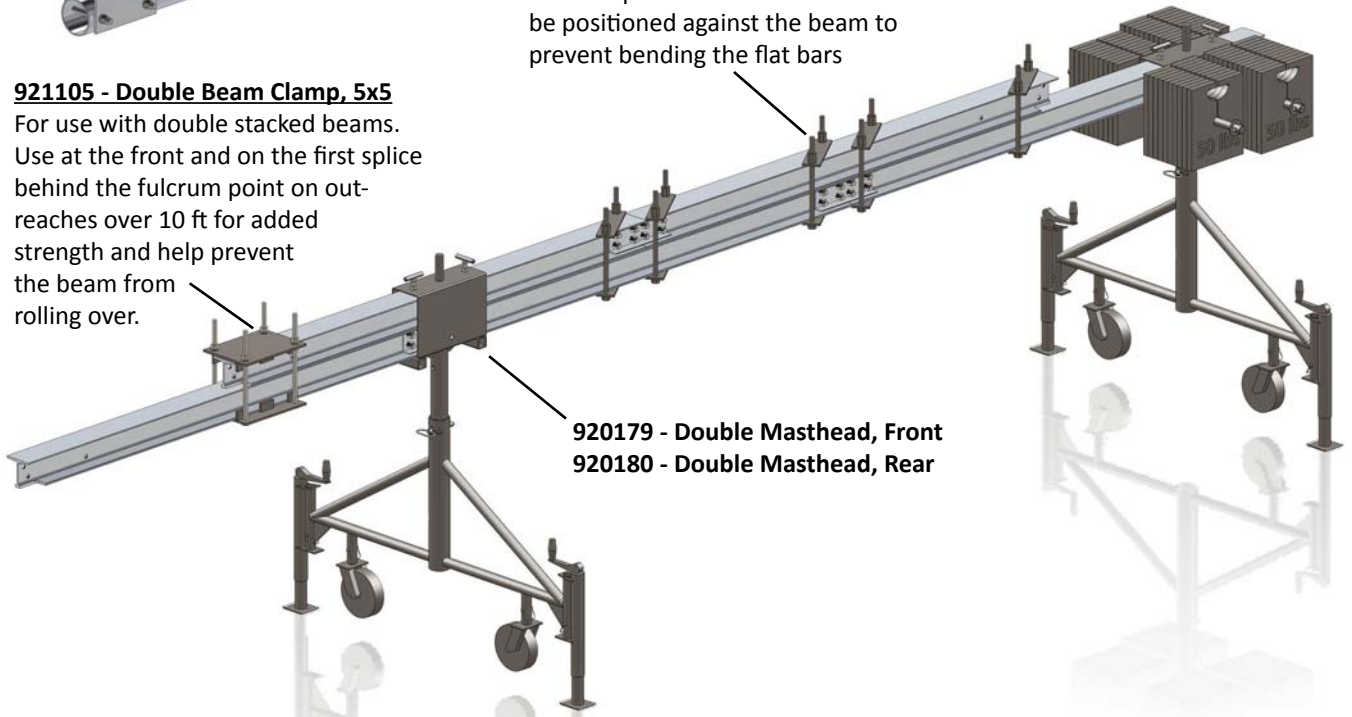

920179 - Double Masthead, Front
920180 - Double Masthead, Rear



Rolling Outrigger Beam, 5x5

Beam Accessories

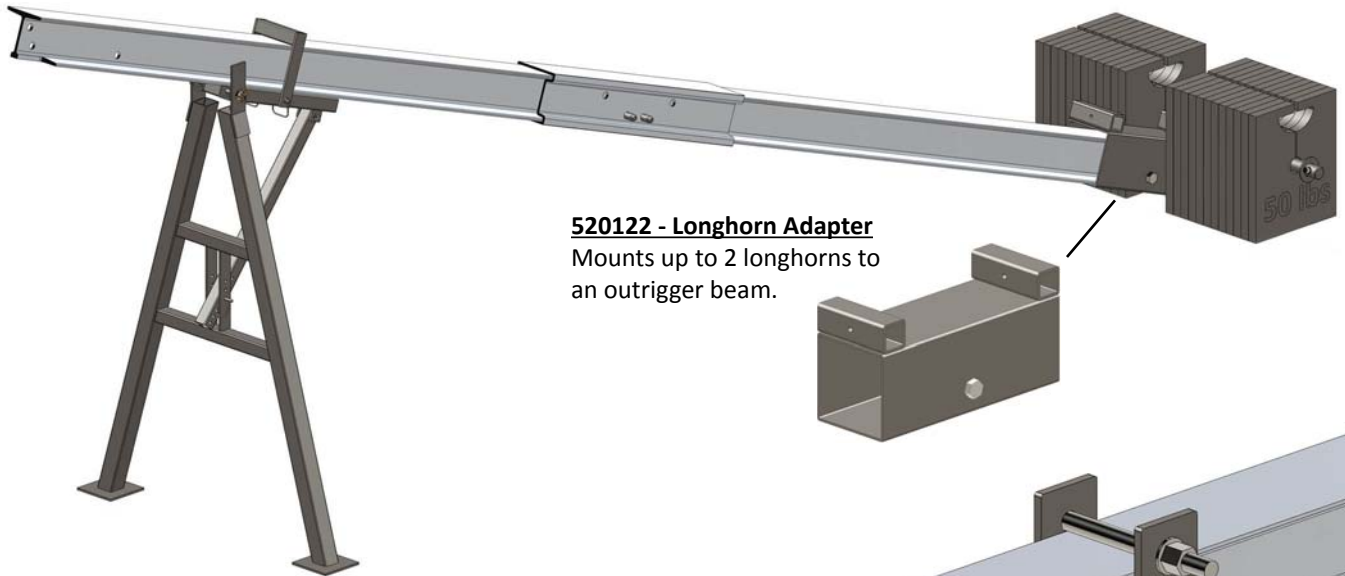

520122 - Longhorn Adapter
Mounts up to 2 longhorns to an outrigger beam.

920171 - Tilt-up Beam Stand

Simplest method for lifting an outrigger beam over a parapet wall. Multiple adjustments for use with a 16 or 24 ft beam assy. Max. outreach: 4'-9" Parapet Clearance at the lowest point: 4'-4".



920165 - Hanger Strap Assy., 5x5
Friction mounted wire rope suspension bracket that will stay in a fixed position once tightened.

920253 - Beam Sleeve, Slide-on

For placing a beam on the roof or on top of parapet walls. Also available:
920251 - Beam Sleeve, Bolt-on
920254 - Beam Sleeve, Double High

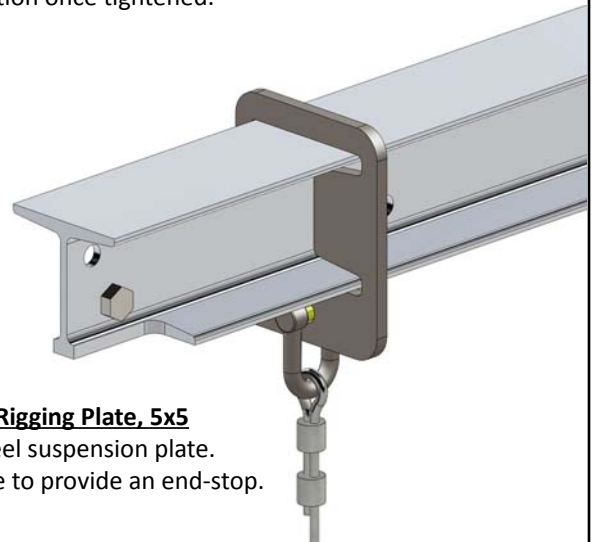
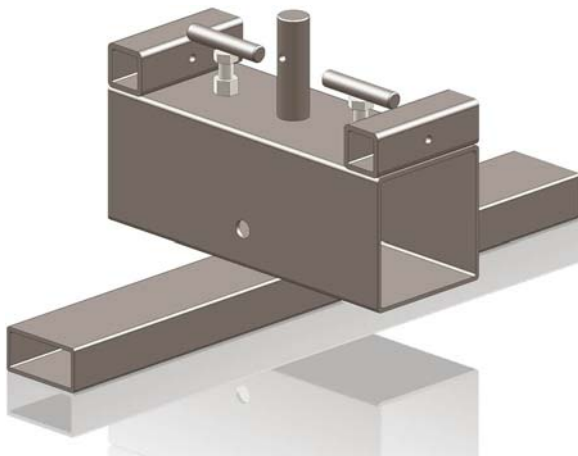

920242 - Rigging Plate, 5x5
Sliding steel suspension plate. Make sure to provide an end-stop.



Rolling Outrigger Beam, 5x5

Assembly Instructions 920115 - Adj. Caster Dolley, 5x5

NOTE:

Assembly must be performed or supervised by a competent and trained person. Read and fully understand these instructions before proceeding with installation.

Assembly Instructions:

1. Slide the top mounting hole of the Jack Assy. (item #1) down over the end tube of the Caster Dolley Base (item #2) until it bottoms out. See illustration on the right.
2. Rotate the Jack Assy. into position and slide the round bar of the Jack Assy. up into the end tube of the Caster Dolley Base and lock with 5/16" bolt or Hitch Pin (item #3).
3. Insert the 900 lb HD Scaffold Casters (item #4) and lock with 5/16" bolt or Hitch Pin.
4. Slide the Masthead (item #5) into the Base and lock into desired height and angle with a 3/4" bolt or Hitch Pin (item #6). Note that the front Masthead can be rotated 45 degrees to either side to allow the beam to be angled into a corner of the building.

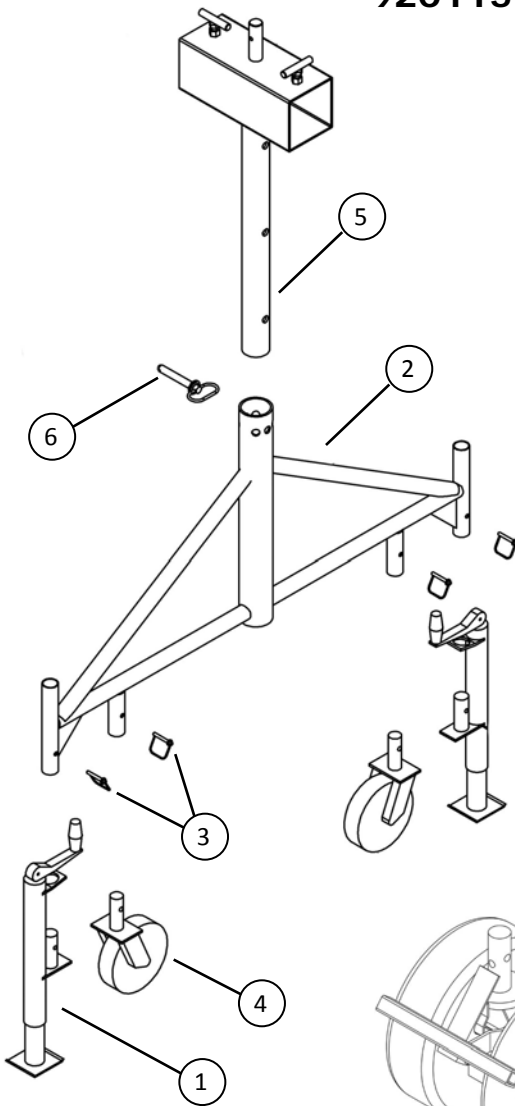
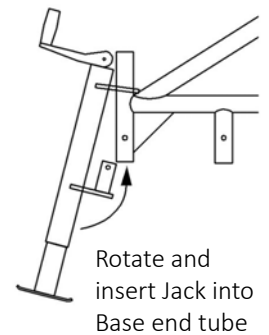
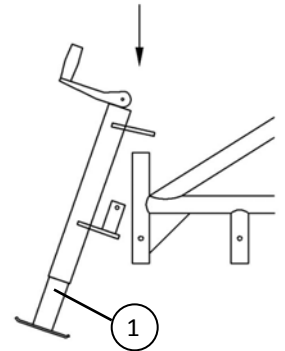

Optional:
920307 - Flat Free Caster with brake

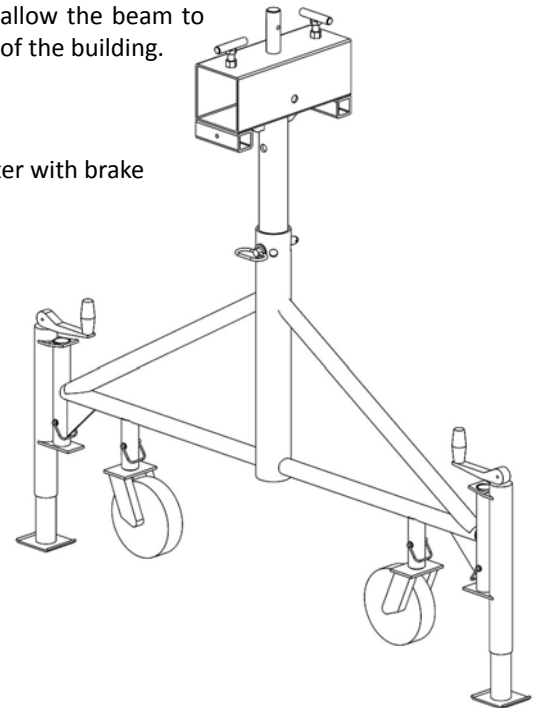
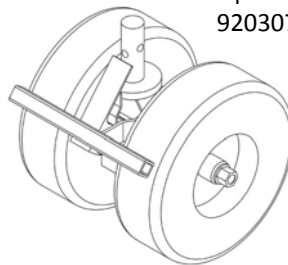

⚠ WARNING:

- Any installation of this equipment other than in strict accordance with these instructions shall be at the Operator's risk and may result in death or serious injury.
- It is the users responsibility to ensure that the structure on which the outrigger beam is placed will support the fulcrum and counterweighted dynamic and static loads.
- Always use a tieback. Never use damaged equipment.
- Do NOT alter this product and never use it for purposes or in ways for which it was not intended.



Rolling Outrigger Beam, 5x5

Assembly Instructions

920514 - Rolling Outrigger, 16 ft LCJ

NOTE:

Assembly must be performed or supervised by a competent and trained person. Read and fully understand these instructions before proceeding with installation. Make sure warning/rating labels are in place, legible and have been read.

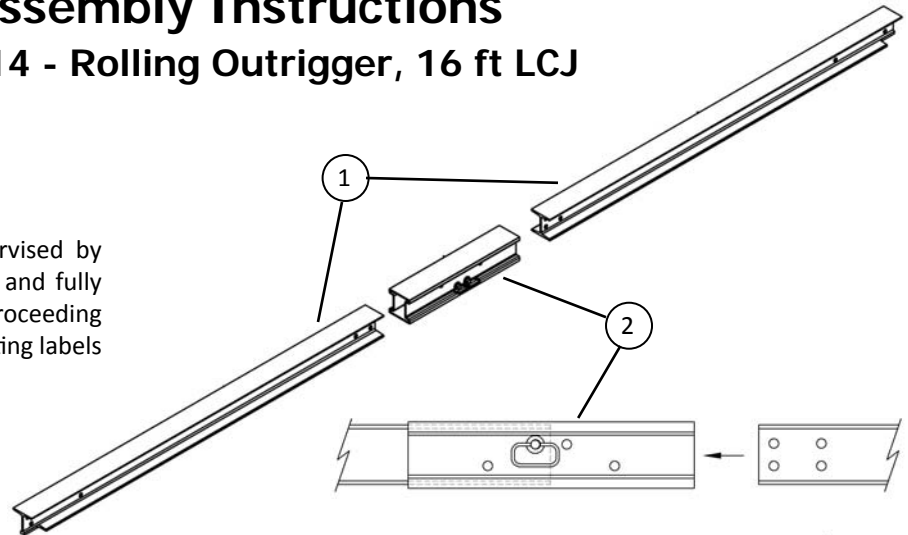

Assembly Instructions:

1. Slide a Front/Rear 5x5 H-beam (item #1) exactly half-way into the Splice Tube (item #2) until the 2 diagonal holes of the beam line up with the diagonal holes of the Splice Tube. Lock beam in place with a 3/4x4-1/2" Hitch Pin (item #3).
2. Slide the other Front/Rear 5x5 H-beam into the Splice Tube until it touches the first beam and make sure the 2 diagonal holes of the second beam line up with the remaining 2 diagonal holes of the Splice Tube. Lock beam in place with a 3/4x4-1/2" Hitch Pin.
3. Pull on the beam sections to make sure they're locked in place.
4. Slide the 16 ft beam assembly into the front and rear mastheads of the previously assembled Caster Dollies (item #4 see page 11).

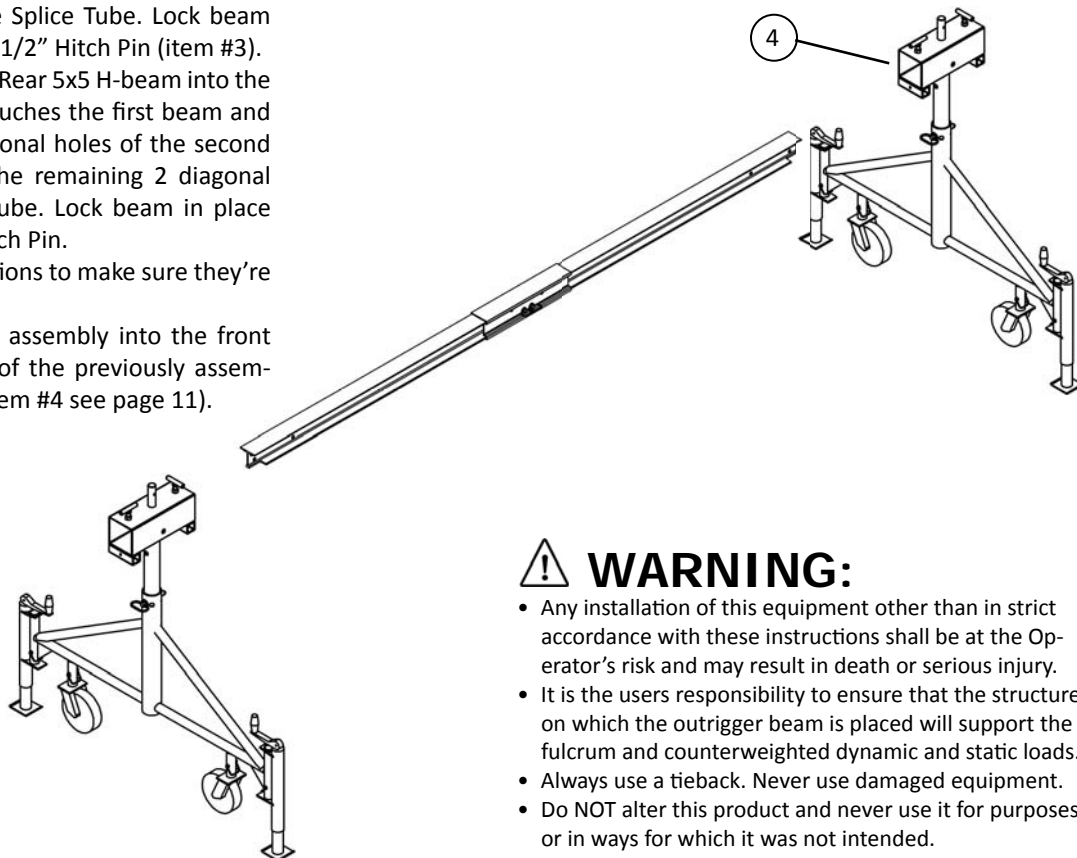
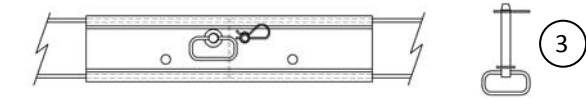

! WARNING:

- Any installation of this equipment other than in strict accordance with these instructions shall be at the Operator's risk and may result in death or serious injury.
- It is the users responsibility to ensure that the structure on which the outrigger beam is placed will support the fulcrum and counterweighted dynamic and static loads.
- Always use a tieback. Never use damaged equipment.
- Do NOT alter this product and never use it for purposes or in ways for which it was not intended.



Rolling Outrigger Beam, 5x5

Assembly Instructions

920514 - Rolling Outrigger, 16 ft LCJ

Assembly Instructions continued:

5. Position the front Caster Dolley in the desired out-reach and tighten the T-handles (item #5) hand tight to lock the Caster Dolley onto the Front Beam.
 NOTE: measure outreach from CENTER of Masthead (NOT the front!) to the wire rope attachment point.
6. Position the rear Caster Dolley so the mounting hole in the Masthead lines up with the hole in the beam. Insert the 3/4x8" bolt (item #6) and tighten the lock nut until snug.
7. Insert the Longhorn (item #7) into the bottom rear tube of the rear Masthead and lock with a 5/16" bolt or hitch pin (item #8).
8. Evenly slide a maximum of 24 counterweights (item #9) onto the longhorn. If more counterweights are required, install a second Longhorn into the bottom front tube of the rear Masthead.
9. Lock the counterweights on each side with a washer and 5/16" bolt or hitch pin (item #10).
10. Attach a tieback cable to a structurally sound anchorage on the building/structure.
11. Attach the suspension wire rope.

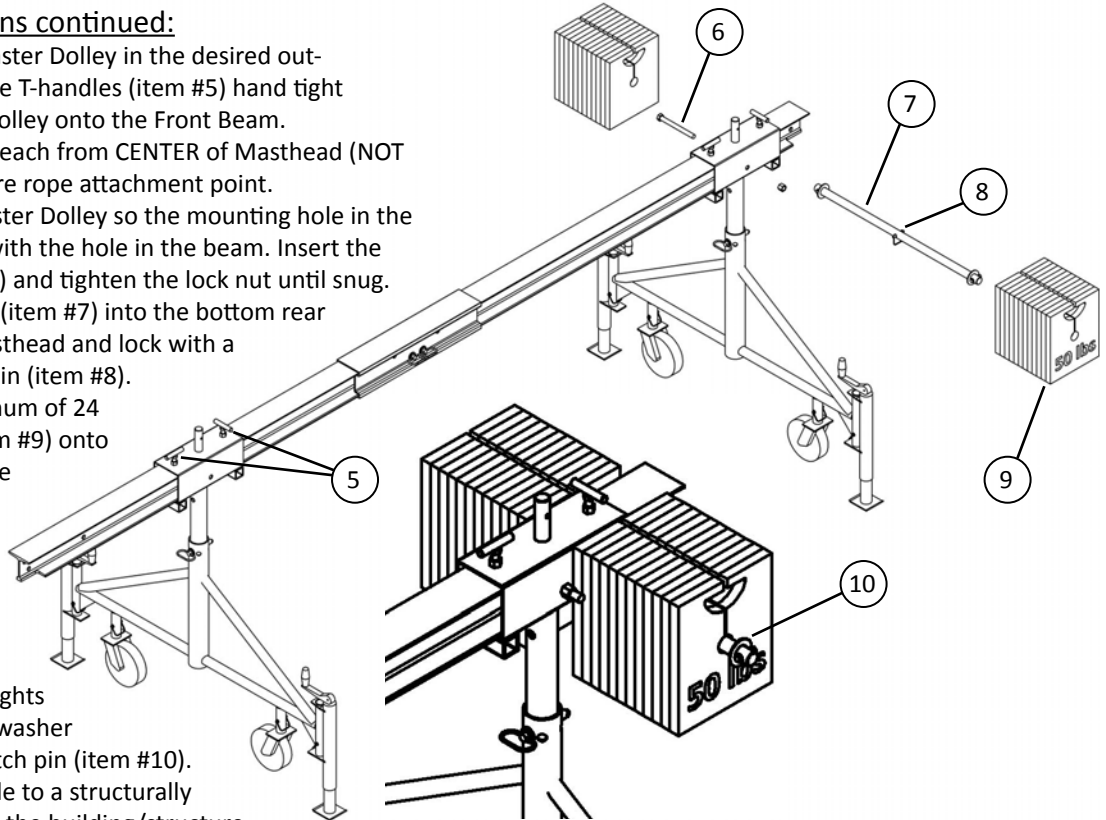

TIEBACK cable to a structurally sound anchorage.

COUNTERWEIGHT CHART

of 50 lb counterweights required for indicated outreach and hoist rated load.

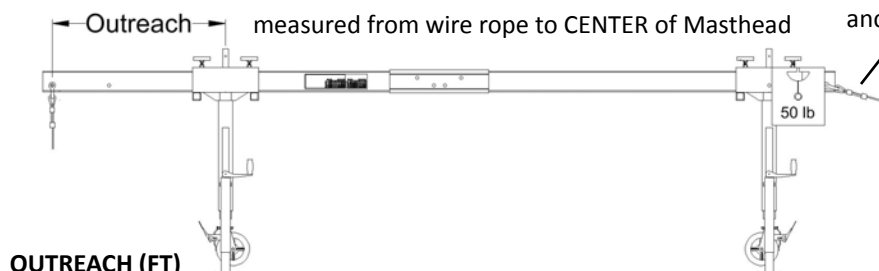

OUTREACH (FT)

		1.0	1.5	2.0	2.5	3.0	3.5	4.0	4.5	5.0	5.5	6.0
HOIST RATED LOAD CAPACITY (LB)	750	5	7	9	12	15	18	22	26	31	36	42
	1000	6	9	12	16	20	24	30	36	42	N/A	N/A
	1250	7	11	15	20	25	31	38	N/A	N/A	N/A	N/A
	1500	9	13	18	24	30	38	N/A	N/A	N/A	N/A	N/A

N/A= Not Allowed



Rolling Outrigger Beam, 5x5

Assembly Instructions

920524 - Rolling Outrigger, 24 ft LCJ

NOTE:

Assembly must be performed or supervised by a competent and trained person. Read and fully understand these instructions before proceeding with installation. Make sure warning/rating labels are in place, legible and have been read.

Assembly Instructions:

1. Slide a Front/Rear 5x5 H-beam (item #1) exactly half-way into the Splice Tube (item #2) until the 2 diagonal holes of the beam line up with the diagonal holes of the Splice Tube. Lock beam in place with a 3/4x4-1/2" Hitch Pin (item #3).
2. Slide the Middle 5x5 H-beam (item #11) into the Splice Tube until it touches the first beam and make sure the 2 diagonal holes of the middle beam line up with the remaining 2 diagonal holes of the Splice Tube. Lock beam in place with a 3/4x4-1/2" Hitch Pin.
3. Repeat procedure with the last beam section.
4. Pull on the beam sections to make sure they're locked in place.
5. Slide the 24 ft beam assembly into the front and rear mastheads of the previously assembled Caster Dollies (item #4 see page 11).

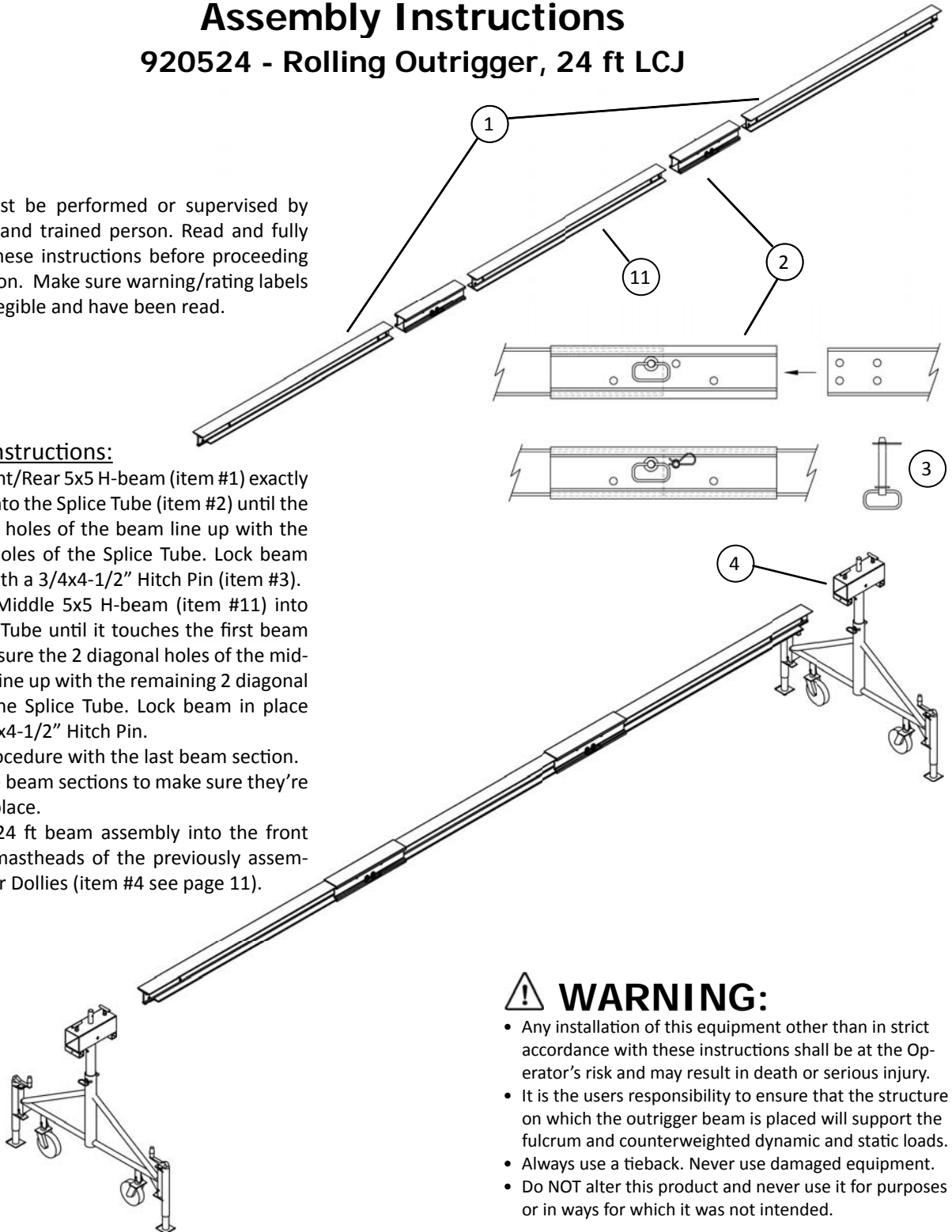

! WARNING:

- Any installation of this equipment other than in strict accordance with these instructions shall be at the Operator's risk and may result in death or serious injury.
- It is the users responsibility to ensure that the structure on which the outrigger beam is placed will support the fulcrum and counterweighted dynamic and static loads.
- Always use a tieback. Never use damaged equipment.
- Do NOT alter this product and never use it for purposes or in ways for which it was not intended.



Rolling Outrigger Beam, 5x5

Assembly Instructions

920524 - Rolling Outrigger, 24 ft LCJ

Assembly Instructions continued:

6. Position the front Caster Dolley in the desired out-reach and tighten the T-handles (item #5) hand tight to lock the Caster Dolley onto the Front Beam.
 NOTE: measure outreach from CENTER of Masthead (NOT the front!) to the wire rope attachment point.
7. Position the rear Caster Dolley so the mounting hole in the Masthead lines up with the hole in the beam. Insert the 3/4x8" bolt (item #6) and tighten the lock nut until snug.
8. Insert the Longhorn (item #7) into the bottom rear tube of the rear Masthead and lock with a 5/16" bolt or hitch pin (item #8).
9. Evenly slide a maximum of 24 counterweights (item #9) onto the longhorn. If more counterweights are required, install a second Longhorn into the bottom front tube of the rear Masthead.
10. Lock the counterweights on each side with a washer and 5/16" bolt or hitch pin (item #10).
11. Attach a tieback cable to a structurally sound anchorage on the building/structure.
12. Attach the suspension wire rope.

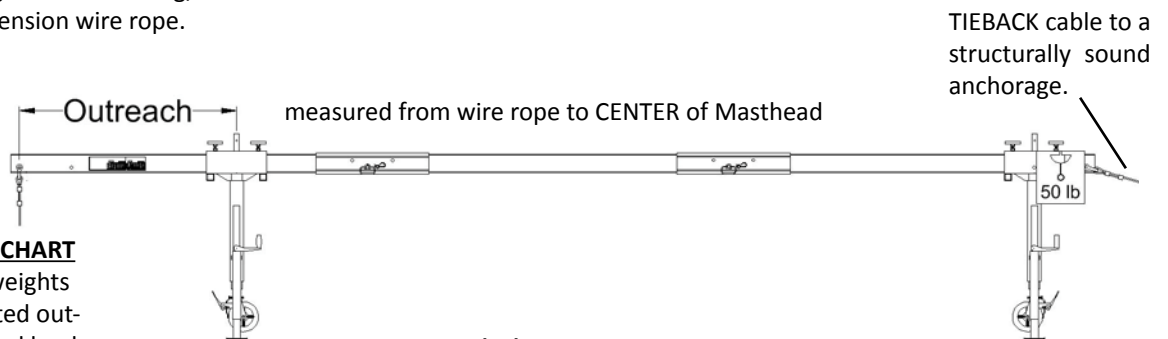
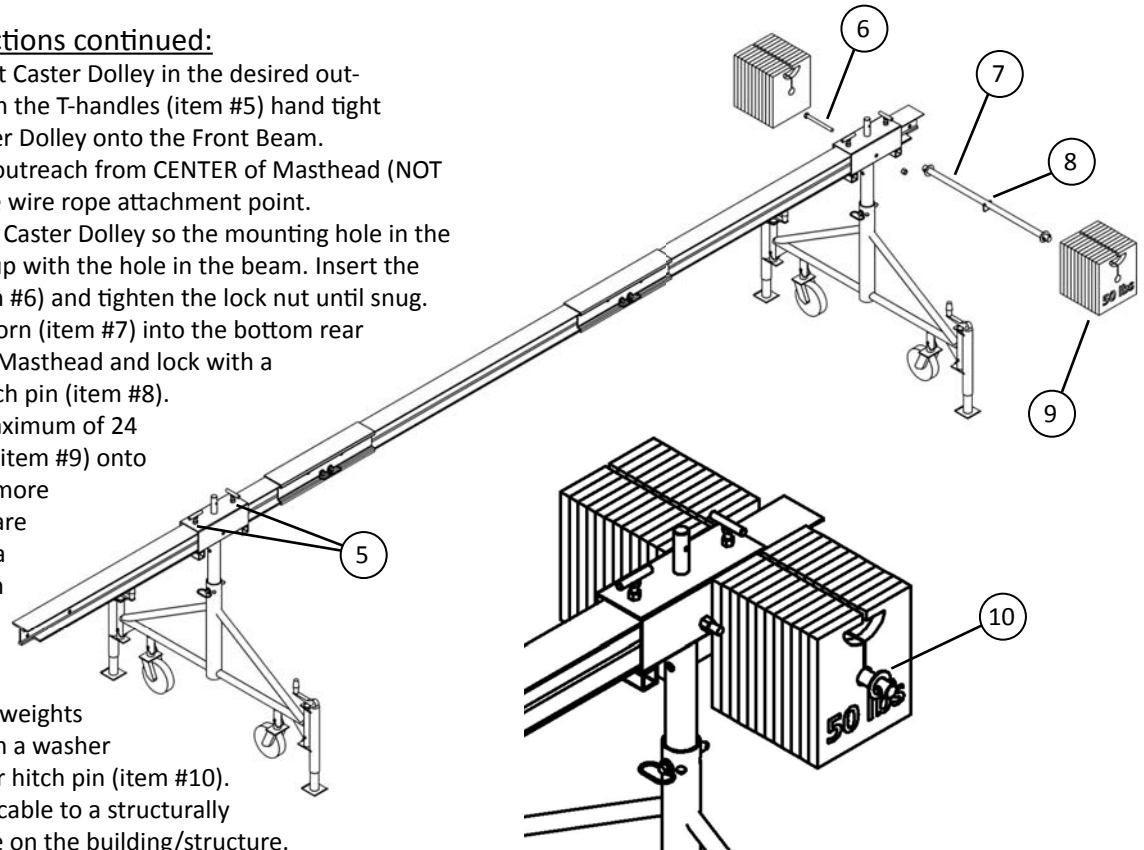

COUNTERWEIGHT CHART
 # of 50 lb counterweights required for indicated outreach and hoist rated load.

		OUTREACH (FT)										
		1.0	1.5	2.0	2.5	3.0	3.5	4.0	4.5	5.0	5.5	6.0
HOIST RATED LOAD CAPACITY (LB)	750	3	5	6	8	9	11	13	15	17	19	21
	1000	4	6	8	10	12	14	17	20	22	N/A	N/A
	1250	5	7	10	12	15	18	21	N/A	N/A	N/A	N/A
	1500	6	9	12	15	18	22	N/A	N/A	N/A	N/A	N/A

N/A= Not Allowed



Rolling Outrigger Beam, 5x5

Assembly Instructions

920527 - Rolling Outrigger, 24 ft LLCJT

NOTE:

Assembly must be performed or supervised by a competent and trained person. Read and fully understand these instructions before proceeding with installation. Make sure warning/rating labels are in place, legible and have been read.

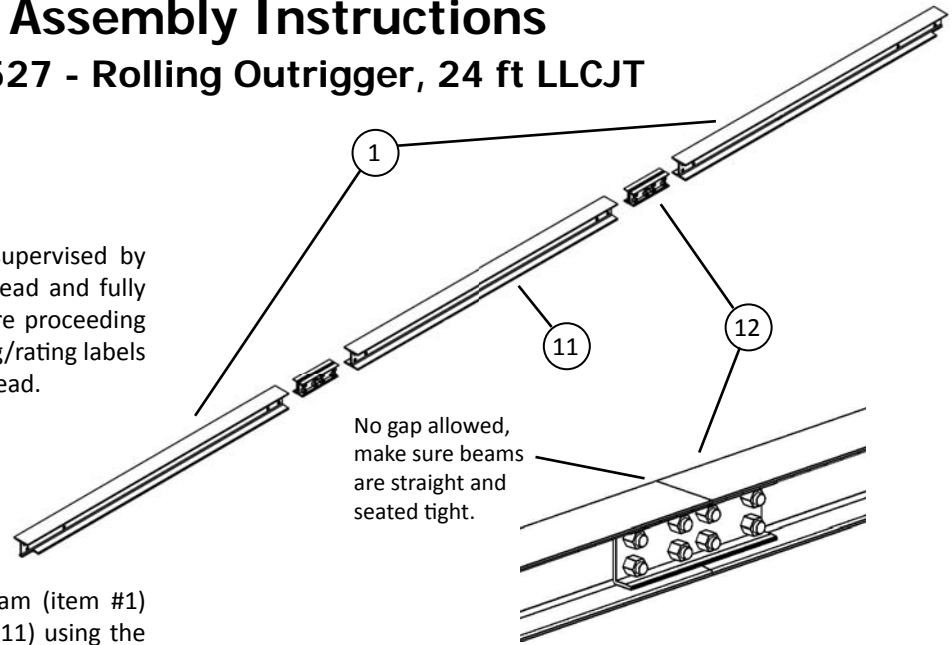

Assembly Instructions:

1. Connect a Front/Rear 5x5 H-beam (item #1) to a Middle 5x5 H-beam (item #11) using the Splice Plate Assembly (item #12). First tighten the lock nuts onto the 8 bolts (3/4x2") until snug. Make sure the beams are seated tight against each other (no gaps) and then torque the bolts to a minimum of 110 lb.ft.
2. Repeat procedure with the third beam section.
3. Slide the 24 ft beam assembly into the front and rear mastheads of the previously assembled Caster Dollies (item #4 see page 11).
4. Position the front Caster Dolley in the desired outreach and tighten the T-handles (item #5) hand tight to lock the Caster Dolley onto the Front Beam. NOTE: measure outreach from CENTER of Masthead (NOT the front!) to the wire rope attachment point.

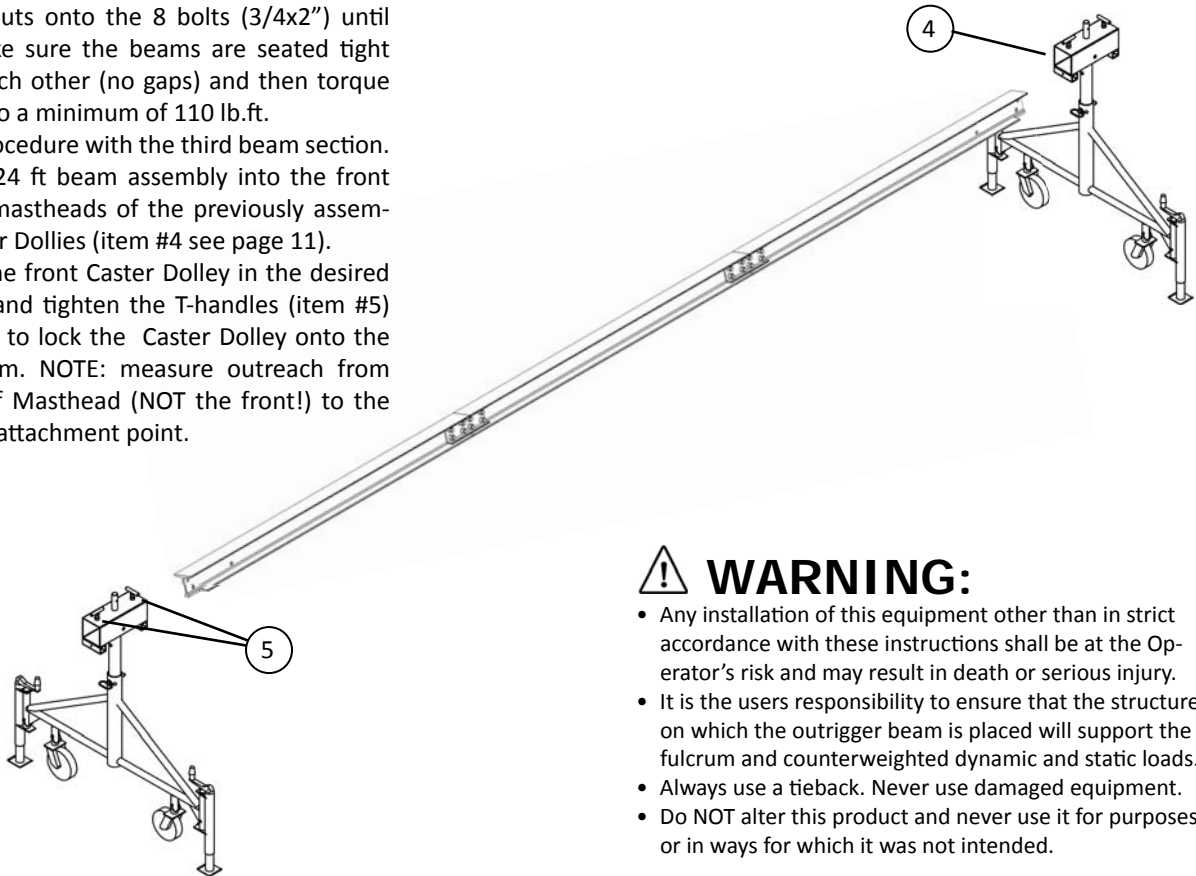

! WARNING:

- Any installation of this equipment other than in strict accordance with these instructions shall be at the Operator's risk and may result in death or serious injury.
- It is the users responsibility to ensure that the structure on which the outrigger beam is placed will support the fulcrum and counterweighted dynamic and static loads.
- Always use a tieback. Never use damaged equipment.
- Do NOT alter this product and never use it for purposes or in ways for which it was not intended.



Rolling Outrigger Beam, 5x5

Assembly Instructions

920527 - Rolling Outrigger, 24 ft LLCJT

Assembly Instructions continued:

5. Position the rear Caster Dolley so the mounting hole in the Masthead lines up with the hole in the beam. Insert the 3/4x8" bolt (item #6) and tighten the lock nut until snug.
6. Install the Cable Truss Assembly (item #13) by first mounting the stem of the screwjack to the front Masthead receiver tube. Lower the screwjack nut all the way down to provide maximum slack. With the cable tube installed onto the screwjack, hook both ends of the cable around the front and rear ends of the beam. Tighten the screwjack nut until the cable is taut and the beam still level. DO NOT overtighten the cable and let the beam bow up.
7. Insert the Longhorns (item #7) into the bottom tubes of the rear Masthead and lock with 5/16" bolts or hitch pins (item #8).
8. Evenly slide a maximum of 24 counterweights (item #9) onto the rear longhorn. Install remaining weights onto the front longhorn.
9. Lock the counterweights on each side with a washer and 5/16" bolt or hitch pin (item #10).
10. Attach a tieback cable to a structurally sound anchorage on the building/structure.
11. Attach the suspension wire rope.

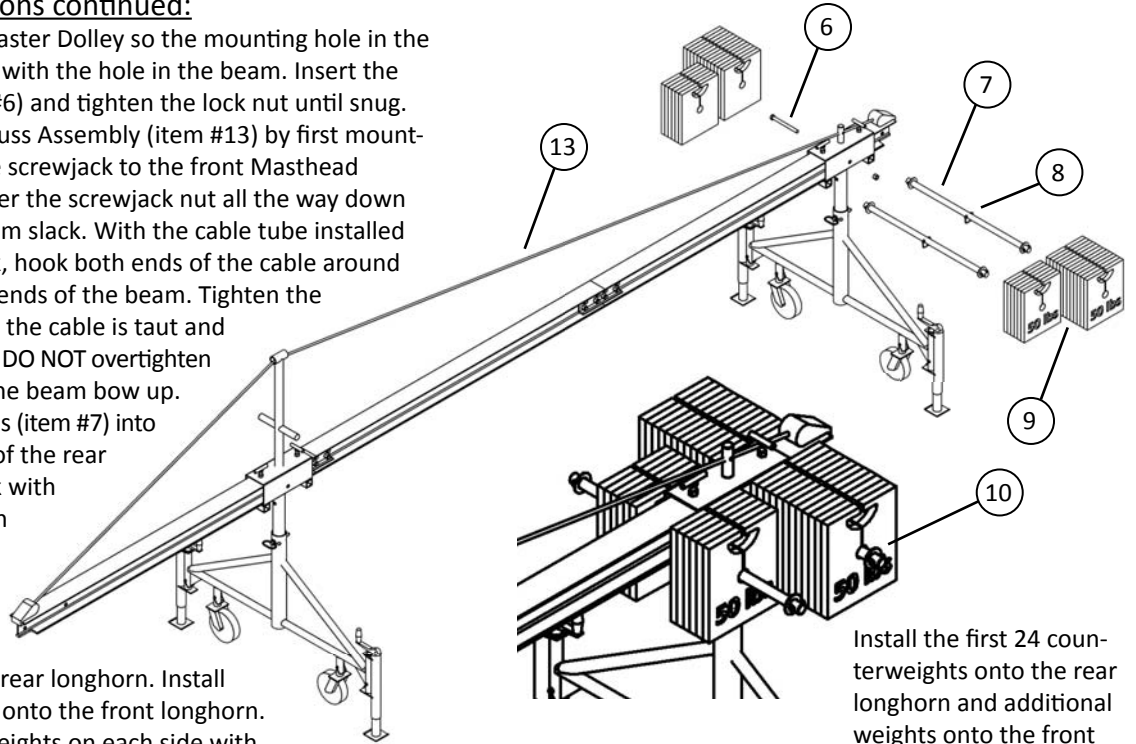

Install the first 24 counterweights onto the rear longhorn and additional weights onto the front longhorn.

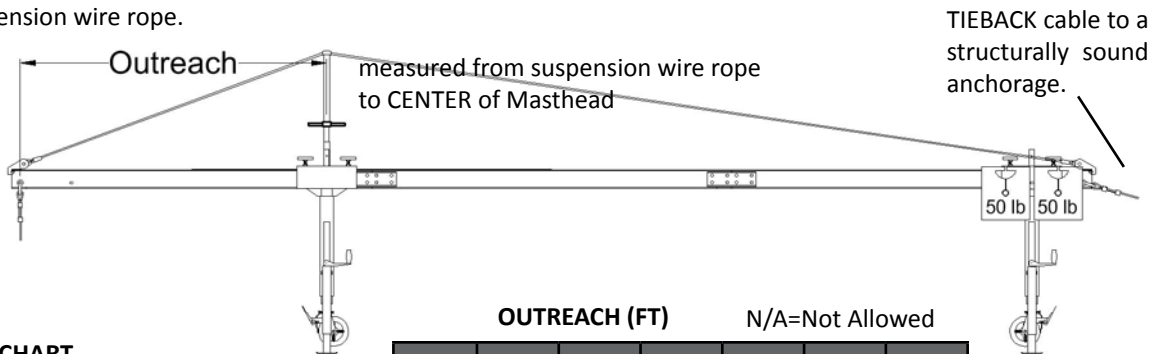

COUNTERWEIGHT CHART

of 50 lb counterweights required for indicated outreach and hoist rated load.

HOIST RATED LOAD CAPACITY (LB)

	OUTREACH (FT)						N/A=Not Allowed
	5.5	6.0	6.5	7.0	7.5	8.0	
750	19	21	24	26	30	33	
1000	25	29	32	36	N/A	N/A	
1250	32	36	N/A	N/A	N/A	N/A	
1500	N/A	N/A	N/A	N/A	N/A	N/A	



Rolling Outrigger Beam, 5x5

Assembly Instructions

920528 - Rolling Outrigger, 24 ft LLCJ8

NOTE:

Assembly must be performed or supervised by a competent and trained person. Read and fully understand these instructions before proceeding with installation. Make sure warning/rating labels are in place, legible and have been read.

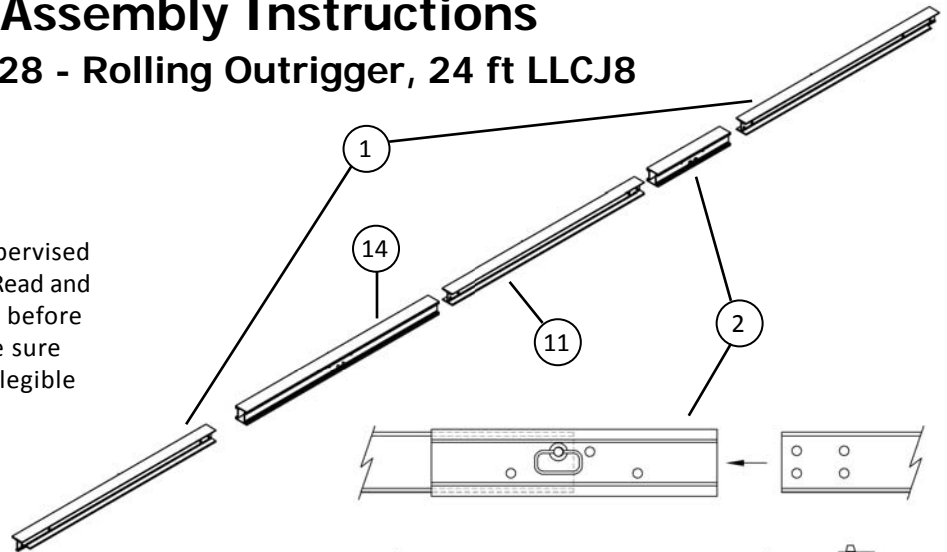

Assembly Instructions:

1. Slide a Front/Rear 5x5 H-beam (item #1) exactly half-way into the 8 ft Splice Tube (item #14) until the 2 diagonal holes of the beam line up with the first 2 diagonal holes of the Splice Tube. Lock beam in place with a 3/4x4-1/2" Hitch Pin (item #3).
2. Slide the Middle 5x5 H-beam (item #11) into the tube until it touches the first beam and make sure the 2 diagonal holes of the middle beam line up with the remaining 2 diagonal holes of the 8 ft Splice Tube. Lock beam in place with a 3/4x4-1/2" Hitch Pin.
3. Repeat procedure with the last beam section and the 3 ft Splice Tube (item #2).
4. Pull on the beams to make sure they're locked in place.
5. Slide the 24 ft beam assembly into the front and rear mastheads of the previously assembled Caster Dollies (item #4 see page 11).

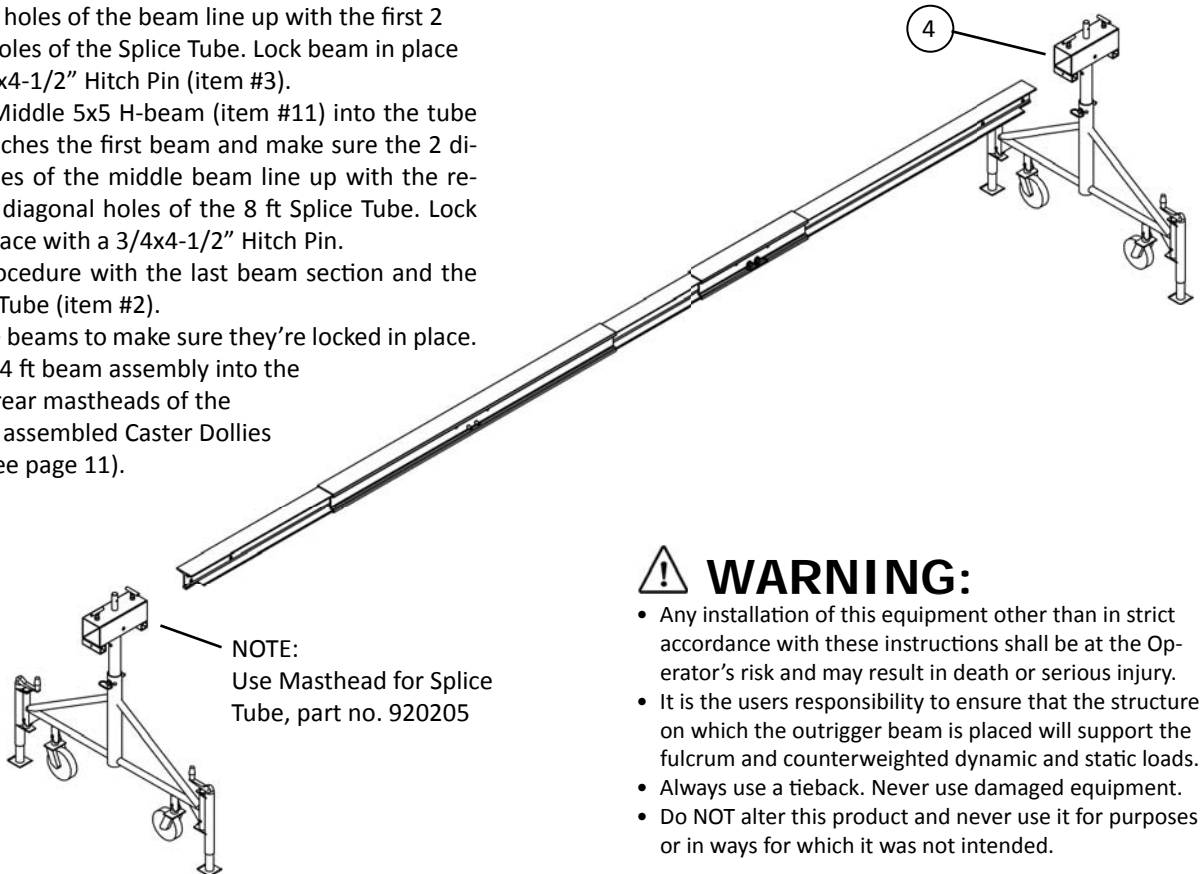

NOTE:
Use Masthead for Splice Tube, part no. 920205

! WARNING:

- Any installation of this equipment other than in strict accordance with these instructions shall be at the Operator's risk and may result in death or serious injury.
- It is the users responsibility to ensure that the structure on which the outrigger beam is placed will support the fulcrum and counterweighted dynamic and static loads.
- Always use a tieback. Never use damaged equipment.
- Do NOT alter this product and never use it for purposes or in ways for which it was not intended.



Rolling Outrigger Beam, 5x5

Assembly Instructions

920528 - Rolling Outrigger, 24 ft LLCJ8

Assembly Instructions continued:

6. Position the front Caster Dolley in the desired out-reach and tighten the T-handles (item #5) hand tight to lock the Caster Dolley onto the Front Beam.
 NOTE: measure outreach from CENTER of Masthead (NOT the front!) to the wire rope attachment point.
7. Position the rear Caster Dolley so the mounting hole in the Masthead lines up with the hole in the beam. Insert the 3/4x8" bolt (item #6) and tighten the lock nut until snug.
8. Insert the Longhorn (item #7) into the bottom rear tube of the rear Masthead and lock with a 5/16" bolt or hitch pin (item #8).
9. Evenly slide a maximum of 24 counterweights (item #9) onto the longhorn. If more counterweights are required, install a second Longhorn into the bottom front tube of the rear Masthead.
10. Lock the counterweights on each side with a washer and 5/16" bolt or hitch pin (item #10).
11. Attach a tieback cable to a structurally sound anchorage on the building/structure.
12. Attach the suspension wire rope.

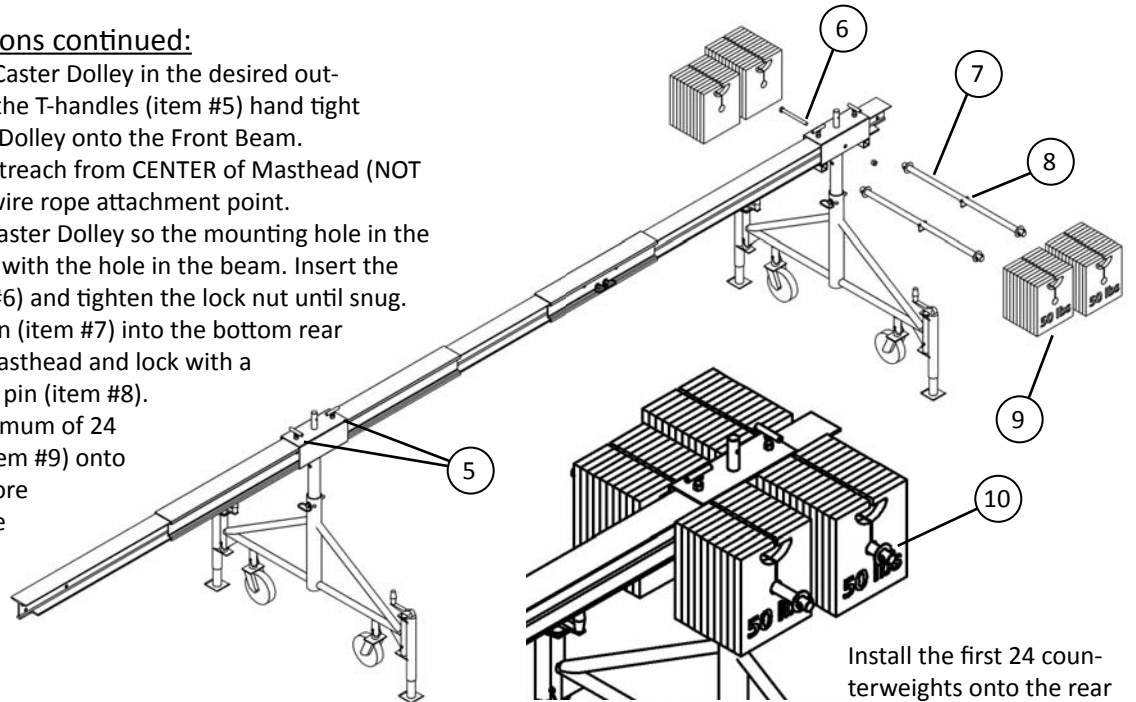

Install the first 24 counterweights onto the rear longhorn and any additional weights needed onto the front longhorn.

TIEBACK cable to a structurally sound anchorage.

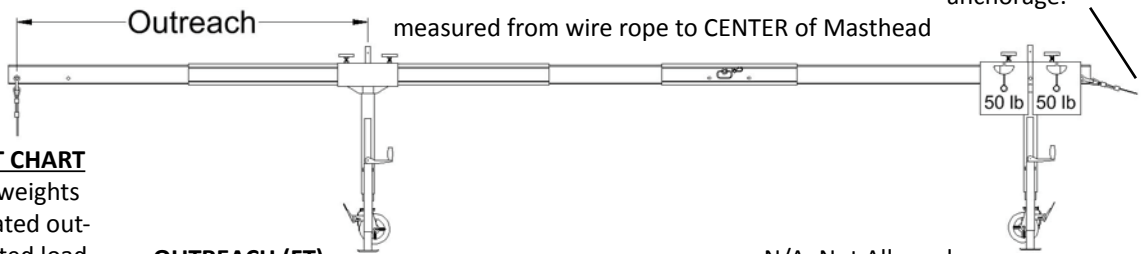

COUNTERWEIGHT CHART
 # of 50 lb counterweights required for indicated outreach and hoist rated load.

HOIST RATED LOAD CAPACITY (LB)	OUTREACH (FT)												
	2.0	2.5	3.0	3.5	4.0	4.5	5.0	5.5	6.0	6.5	7.0	7.5	8.0
750	6	8	9	11	13	15	17	19	21	24	26	30	33
1000	8	10	12	14	17	20	22	25	29	32	36	40	44
1250	10	12	15	18	21	24	28	32	36	41	45	N/A	N/A
1500	12	15	18	22	25	30	34	39	44	N/A	N/A	N/A	N/A



Rolling Outrigger Beam, 5x5

Labels

822115 Label, Beam 5x5 "CW Chart..."

WARNING

Failure to comply with allowable outreaches and required counterweights can result in death or serious injury. Cable truss assembly is required for long outreaches as shown on chart at right. Tieback to structurally sound portion of building is required at all times.

Bee Access Products
Counterweight Charts
Rolling Outrigger, 5x5(x5/16") Aluminum

Acceptable outreaches with required number of 50 lb. counterweights for 16 and 24 ft configurations.

Chart is based on using longhorns that position the center of the counterweights at 9 in. from the rear (up to 24 weights) and 16 in. from the rear (using 25 weights or more). If another method of fastening the counterweights is used that moves the center of the weights back to within 3 in. of the rear of the beam, adjust the weights as follows: Subtract 1 weight if the chart number indicates less than 25 weights. Subtract 2 weights if the chart number indicates 25 weights or more.

Outreach is distance from center of front beam support to suspension wire.

Use splice plates or splice tubes

16 ft configuration

HOIST RATED CAPACITY	OUTREACH IN FEET										NA-NOT ALLOWED		
	1.0	1.5	2.0	2.5	3.0	3.5	4.0	4.5	5.0	5.5	6.0		
750	5	7	9	12	15	18	22	26	31	36	42	NA	NA
1000	6	9	12	16	20	24	30	36	42	NA	NA	NA	NA
1250	7	11	15	20	25	31	38	NA	NA	NA	NA	NA	NA
1500	9	13	18	24	30	38	NA	NA	NA	NA	NA	NA	NA

Install the first 24 counterweights onto the rear longhorn, then continue loading the weights onto the front longhorn.

NOTE: Cable Truss is only required when outreaches below exceed those from the left table.

Parapet clearance is adjustable from 42 to 74 inches. Diagonal bracing required at highest setting, part no. 920150.

24 ft configuration

HOIST RATED CAPACITY	OUTREACH IN FEET										NA-NOT ALLOWED				
	2.0	2.5	3.0	3.5	4.0	4.5	5.0	5.5	6.0	6.5	7.0	7.5	8.0		
750	8	8	9	11	13	15	17	19	21	24	28	30	33	NA	NA
1000	8	10	12	14	17	20	22	25	29	32	36	NA	NA	NA	NA
1250	10	12	15	18	21	24	28	32	36	NA	NA	NA	NA	NA	NA
1500	12	15	18	22	25	30	34	NA	NA	NA	NA	NA	NA	NA	NA

Part No. 822115

WL-FALL Warning Label, Fall Hazard

ADVERTENCIA

Riesgo de Caída.

Fallas en la instalación o uso de este producto pueden resultar en muerte o lesiones graves. Siga los procedimientos recomendados por el fabricante. Los sistemas de andamios suspendidos deben ser instalados y desmontados por o bajo la supervisión de una persona entrenada y competente. No altere este producto o cualquiera de sus componentes y nunca lo use para propósitos o de manera para la cual no han sido diseñados. Inspeccionar todo el equipo antes de cada uso. Nunca use equipo dañados.

www.beeaccess.com part# WL-FALL

WARNING

Fall Hazard.

Failure to properly install and use this product may result in death or serious injury. Follow the manufacturer's recommended procedures. Suspended Scaffold Systems must be installed and dismantled by, or under the supervision of, a trained and competent person. Do not alter this product and never use it for purposes or in ways for which it was not intended. Inspect all equipment before each use. Never use damaged equipment.

822120 Label, Splice Tube

WARNING

Failure to properly install this splice tube may result in injury or death.

Bee Access Products
www.beeaccess.com

PARTS LIST:
1 each: 2, 3 or 8 ft Splice Tube
2 each: Quick Pin with Keepers

INSTRUCTIONS: Splice Tube for 6.49 lb./ft. 5x5 H-beam

- Slide the first beam into the splice tube and visually line up hole A of the beam with mounting hole 1 of the Splice Tube.
- Lock the beam to the Splice Tube with the first quick pin.
- Slide the second beam into the Splice Tube until it hits the first beam and lock hole B into hole 2 with the second quick pin.
- Make sure the keepers are installed properly.
- Verify that the beams are secured properly by looking through each pilot hole; you should be able to clearly see through to the pilot hole on the other side of the splice tube.
- Max. outreaches without a Cable Truss and using 1000 lbs. hoists:
2 & 3 ft splice tubes: 5 ft
8 ft splice tube: 8 ft

Label No. 822120

© 2012 Bee Access Products. All rights reserved. Manual must be complete and read in its entirety. 12/05/2012 Rev. A Page 20 of 20