



All-Terrain Electric Moto
Enlightenment Mentor

EVO 18 OWNER'S MANUAL

User Manual

1 Note: Manual illustrations are for demonstration purposes only. Illustrations may not reflect the exact appearance of the actual product. Please read and understand the entire manual before allowing your child to use this product! Please read the manual carefully and check whether all parts are in good condition to ensure the safety of your child or your riding. If you find any problem, please contact the dealers in time.

2 Children should ride the bike under the supervision of parents or adults. Children should wear protective equipment (e.g. helmet, gloves, knee pads, elbow pads, etc.) when riding. Note that the bike is not intended for transportation.

3 The bike should be stored in a dry and ventilated place.

4 Please comply with local laws or regulations during the riding; Slow down and increase the braking distance when braking to ensure safety in rainy, snowy day and slippery areas;

5 Non-professional maintenance personnel are prohibited from disassembling and replacing parts. Adults are required to assemble and debug the vehicle, and children are not allowed to operate it.

6 Before riding, check whether the screws of all parts of the vehicle are tightened, whether the tire pressure is normal and whether the brake is normal.

7 When you find the battery is with electricity while the bike cannot be rode, please turn off the bike in time to avoid any damage to the bike.

8 When you get off or push, please turn off the bike power or take off the emergency power switch to prevent the sudden start of the bike and accidents caused by turning the throttle.

9 Do not allow hands, feet, body parts, clothing, or similar objects to come into contact with any rotating or moving parts. (e.g., wheel, motor, disc brake, etc.)

10 Only the special charger of this bike can be used for charging.

11 Warning! Users are reminded to be careful during the riding, as skills are needed to avoid falling or colliding which may cause injury to users or third parties.

12 Riding is prohibited on rivers, highways, places with heavy traffic, crowded places and other dangerous road conditions.

13 The battery can only be charged by adults.

14 The max load of this bike is 50kg;

15 Warning! The bike is designed for the children over 8 years old

16 Warning! Parents or guardians should ensure that children have received proper instruction before riding, especially regarding the safe use of brake systems.

1. Bike assembling.....	3	8.2 Add front and rear brake hydraulic fluid.....	11
1.1 Handlebar assembling.....	3	8.3 Replace the front and rear disc brake pads.....	11
1.2 Front wheel assembling.....	3	9. Wheels.....	12
2. matters need attention.....	4	9.1 Front wheel disassembling.....	12
2.1 Advice on the first ride.....	4	9.2 Front wheel assembling.....	12
2.2 Safety suggestion.....	4	9.3 Rear wheel disassembling.....	13
2.3 Tampering warning.....	4	9.4 Rear wheel assembling.....	13
2.4 Safe operation.....	4	9.5 Check the condition of front and rear tires.....	13
2.5 Protective suit.....	4	9.6 Check front and rear tire pressure.....	13
2.6 Riding environment.....	5	9.7 Check front and rear wheel spoke tension.....	13
2.7 User manual.....	5	10. Battery.....	14
2.8 fire danger.....	5	10.1 Battery remove.....	14
3. Bike view.....	6	10.2 Battery install.....	15
3.1 Whole bike spare parts list.....	6	10.3 Battery charging.....	15
4. Specification.....	7	11. Charger.....	16
4.1 Frame.....	7	11.1 Introduction to Battery Charger.....	16
4.2 Electrical system.....	7	12. Bike cleaning and maintenance.....	16
4.3 Front and rear suspension shock.....	7	12.1 Bike cleaning procedure.....	16
4.4 Tires.....	7	12.2 Related inspection and maintenance procedures.....	16
5. Accessory.....	8	13. Storage and reuse instructions.....	16
5.1 Bike Accessory.....	8	13.1 Storage specification.....	16
6. Bike control.....	9	13.2 Prepare riding instructions after storage.....	16
6.1 Front brake.....	9	14. Electrical troubleshooting.....	17
6.2 Rear brake.....	9	14.1 Battery troubleshooting.....	17
6.3 Emergency power off switch.....	9	14.2 Display troubleshooting.....	17
6.4 Start button.....	9	14.3 Controller troubleshooting.....	17
7. Display.....	10	14.4 Motor troubleshooting.....	17
7.1 Multifunctional element.....	10	14.5 Throttle Power Cannot Be Switched On or Off.....	17
8. Braking system.....	11	15. Warranty.....	18
8.1 Adjust the front and rear disc brake travel.....	11	15.1 Manufacturer's warranty and warranty.....	18

1. Bike assembling

1.1 Handlebar assembling

When you receive the bike, the handlebar and front wheel are disassembled. You need to install the handlebar and front wheel on the bike.

1. Use the M5 hexagon wrench to unscrew the four screws and install the handlebar to the mounting hole of the direction handlebar. Please noted that the middle of the direction handlebar is equipped with kularis, and the kularis should be in the middle and the transverse Angle needs to be adjusted.

2. The brake handle is about 45° horizontally down, and then tighten the four screws with the M4 hexagon wrench.

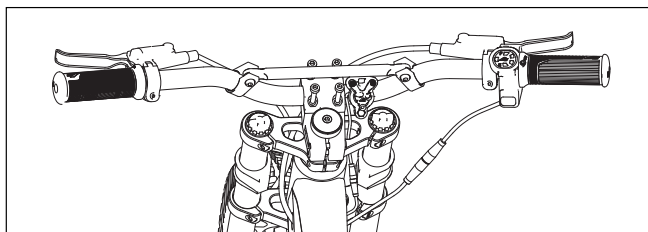
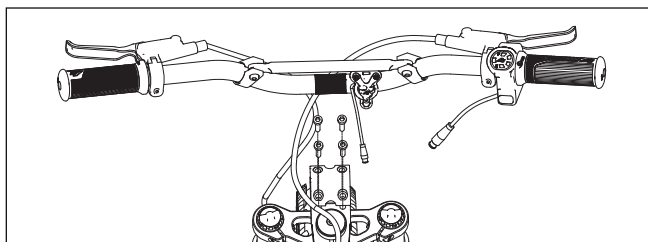

1.2 Front wheel assembling

For front wheel installation, lift the front fork of the vehicle, align the axle on both sides of the front wheel hub with the axle holes at the lower part of the fork. It's important to note that the disc brake rotor should be on the side of the disc brake caliper. Install the front wheel into the fork, apply thread locker on the hub axle, then use the socket tool provided with the vehicle to tighten the left and right fixing screws of the front wheel with 25-30N.m force. It's essential to adjust the disc brake caliper to the appropriate state to avoid friction against the disc brake rotor or brake failure, which could be dangerous for you or third parties.

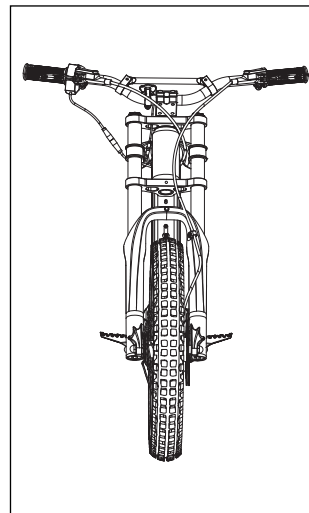
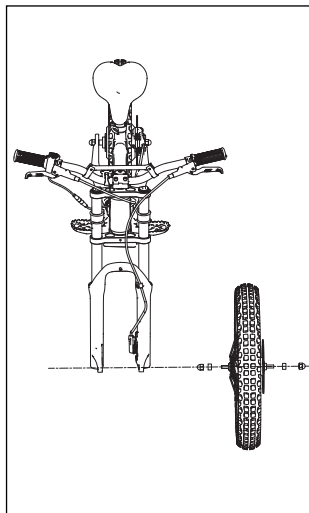

2. Matters need attention

2.1 Advice on the first ride

1. Wear protective gear before riding: helmet, riding clothes, riding boots, gloves, knee pads, elbow pads, goggles
2. On your first ride, you should adjust the speed mode and select one according to the road conditions and your cycling ability
3. This bike is not allowed to carry people;
4. The load of this bike is not allowed to exceed the specified load;
5. Take the emergency switch with you when leaving the bike

2.2 Safety suggestion

This product should be checked for potential safety risks before riding:

1. Whether the fasteners of the whole bike has any loosening.
2. Whether the tires have scratch and crack.
3. Whether the tire pressure meets the riding requirement.
4. Wear protective gear before riding: helmet, riding clothes, riding boots, gloves, knee pads, elbow pads, goggles;

2.3 Tampering warning

It is forbidden to modify the bike without permission, otherwise it cannot guarantee the safe operation. For examples:

1. Replace batteries or motors without permission
2. Replace fasteners without permission
3. Unauthorized replacement of frame structure

2.4 Safe operation

1. Children should not be out of sight of adults while riding
2. When the motor is overheated, wait for the motor to cool down before riding

2.5 Protection suit



2. Matters need attention

2.6 Riding environment

Suggestions on how to deal with some damaged parts after replacement are as follows:

1. Comply with local laws and regulations when handling non-electrical parts
2. When disposing of the replaced batteries, they should be separated from ordinary household garbage, Handle according to local laws and regulations

2.7 User manual

1. Please read the instructions carefully before your first ride. The instructions contain a lot of useful information and tips, which can effectively prevent accidents.

2. If you want to know more about this bike, please contact local dealers.

2.8 Fire danger

Lithium batteries pose a high risk of explosion if a fire occurs near their storage or usage environment. The safety of lithium batteries is primarily determined by their inherent characteristics, closely related to the materials used, the manufacturing process, and the charging and discharging during use.

Under normal usage conditions, lithium batteries are safe.

3.1 Whole bike spare parts list

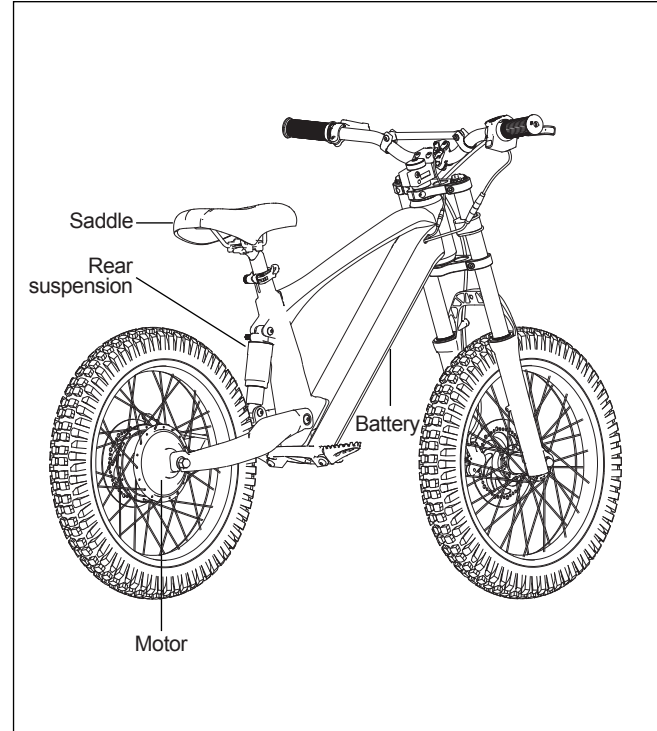
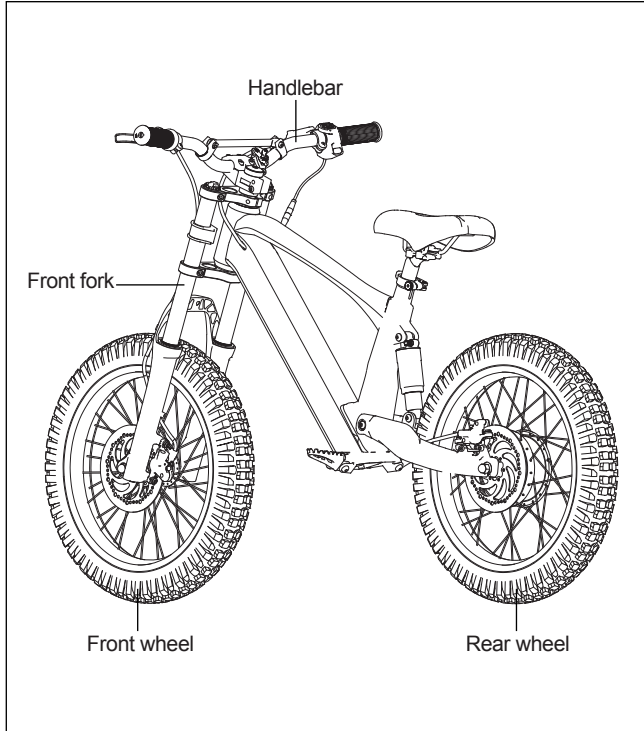

4. Specification

4.1 Frame

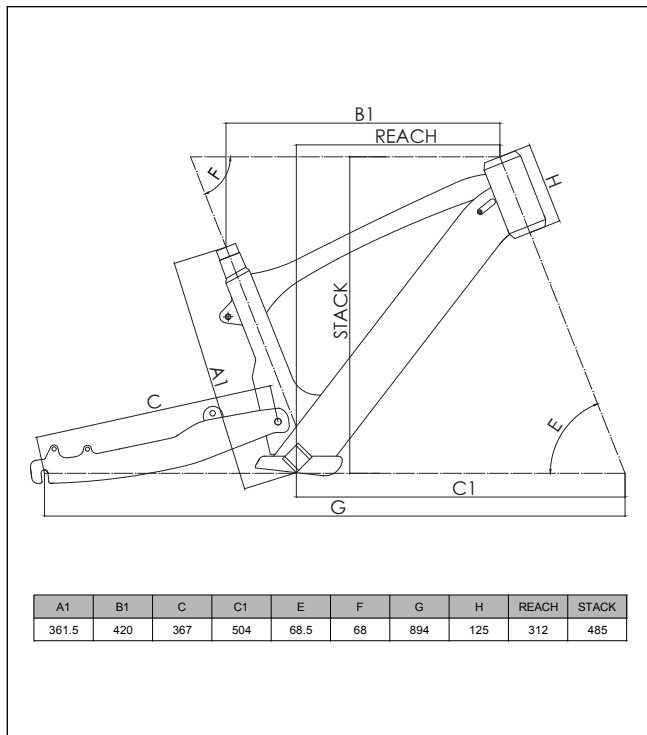

4.2 Electrical system

Name	Parameter
Motor	36V500W
Battery	36V5AH
Controller	36V30A
Charger	42V3A



4.3 Front and rear suspension shock

Name	Parameter
Front Fork	28.6*25.4*194L、travel 80mm
Rear Suspension	pneumatic bumper、travel 30mm、 air pressure 140PSI、center distance 150mm

4.4 Tires

Name	Parameter
Tire	18x2.5, mountain bike tire

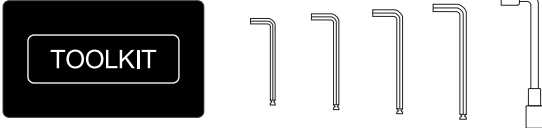
5.1 Bike Accessory

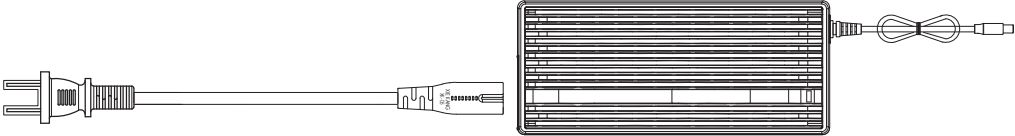
NAME	QTY	PICTURE
Number Plate	1	 A white, shield-shaped number plate with a small circular hole at the bottom center.
Toolkit	1	 A black rectangular box labeled "TOOLKIT" next to five hex keys of different sizes and a long, thin screwdriver.
User Manual	1	 A white user manual cover with a black diagonal stripe and a logo in the top left corner.
Charger	1	 A power adapter with a three-pronged AC plug on the left, a USB-C port in the middle, and a USB-A port on the right connected to a charging cable.

6. Bike control

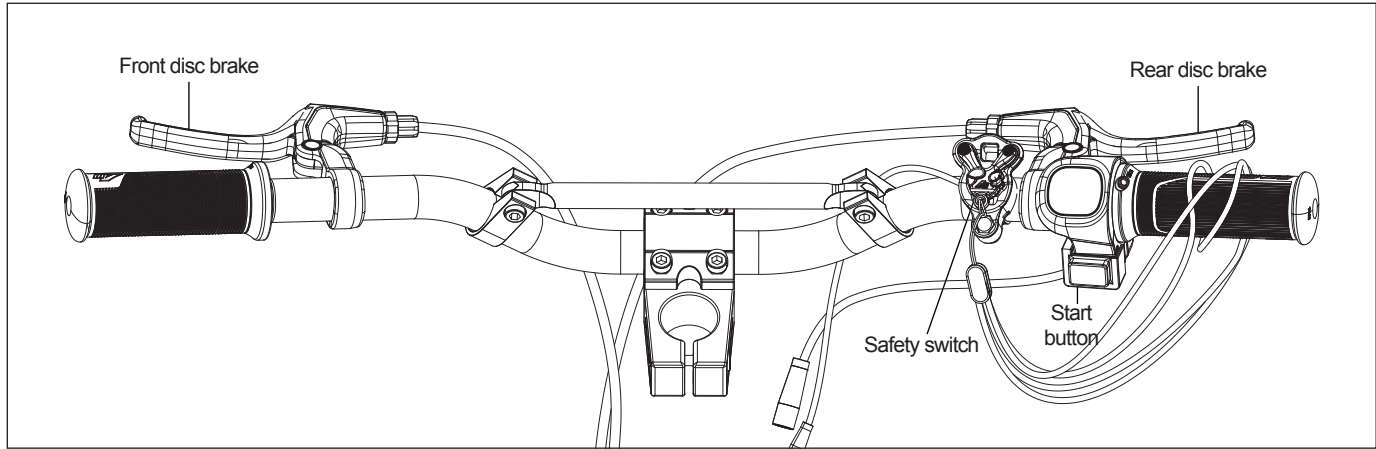

6.1 Front brake

The front disc brakes are used to brake the front wheels and use oil pressure to brake.

6.2 Rear brake

The rear disc brakes are used to brake the rear wheels and use oil pressure to brake.

6.3 Emergency power off switch

Safety switch is used to remove the emergency power outage switch when you get off the car or implement it to prevent the car from turning the speed during the implementation and the accident. Can ride your car.

6.4 Start button

The start-up button is that you use it to start the vehicle when riding a vehicle and shut down the vehicle.

7.1 Multifunctional element

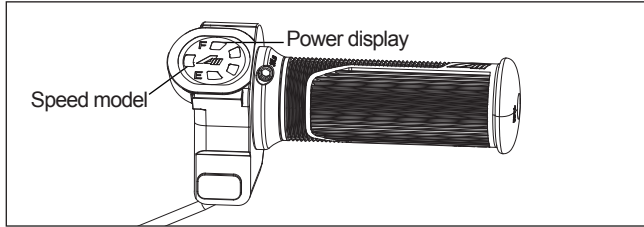

1. Power display mode

The power display shows by four bars, each bar represents 25% of the power. When all four bars are on, it means that the battery power is full. When all bars are off, please charge the battery immediately.

2. Speed Level

Low speed level: 15km/h with green indicator light
Middle speed Level: 22km/h with Yellow indicator light
High Speed level: 30km/h with Red indicator light

3. Charging mode display

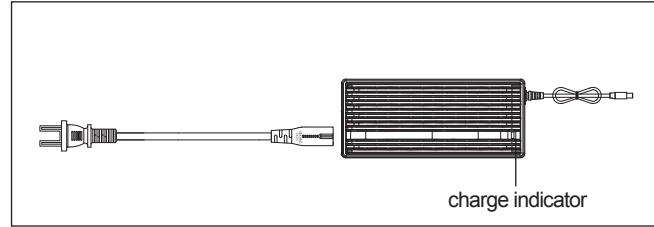

Charging mode display: The color of the indicator light at the illustrated position indicates whether the battery is fully charged. When the indicator light is red, it means it's charging, and when it turns green, it means the battery is fully charged. It's important to unplug the charger when the battery is fully charged to avoid damaging it. When the battery is charging, there is no voltage output from the entire vehicle.

4. Power reduction

The power of this product will be weakened according to the battery voltage drop, which belongs to the natural characteristics of the battery.

8. Braking system

8.1 Adjust the front and rear disc brake travel

The brake travel distance adjusted by the screw of the brake lever. Use the hexagonal wrench # M2, clockwise rotation will increase the brakes travel distance, and the counterclockwise will reduce the brake travel distance.

8.2 Add front and rear brake hydraulic fluid

Add the hydraulic oil , first spin the screw of the injection hole on the top of the brake, drip the hydraulic oil into the screw hole with a syringe, tighten the screw of the oil injection hole, clean the handlebar.

8.3 Replace the front and rear disc brake pads

To replace the brake pads , first remove the callipers fixing screws, use pliers to remove the buckles, take out the pins, and directly take out brake pads and replace the new brake pads , mounting the pins and buckles , tighten the screw of the callipers .

9.1 Front wheel disassembling

To remove the front wheel, first use the socket tool provided with the vehicle to loosen the fixing screws on both sides of the front wheel. Then hold the handlebar, lift the front fork, and the front wheel can be removed.

9.2 Front wheel assembling

For front wheel installation, lift the front fork part of the vehicle, align the axle on both sides of the front wheel hub with the axle holes at the lower part of the fork. It's important that the disc brake rotor is on the side of the disc brake caliper. Install the front wheel into the fork, apply thread locker on the hub axle, then use the socket tool to tighten the left and right fixing screws of the front wheel with 25-30N.m force. It's crucial to adjust the disc brake caliper to the appropriate state to avoid friction against the disc brake rotor or brake failure, which could be dangerous for you or third parties.

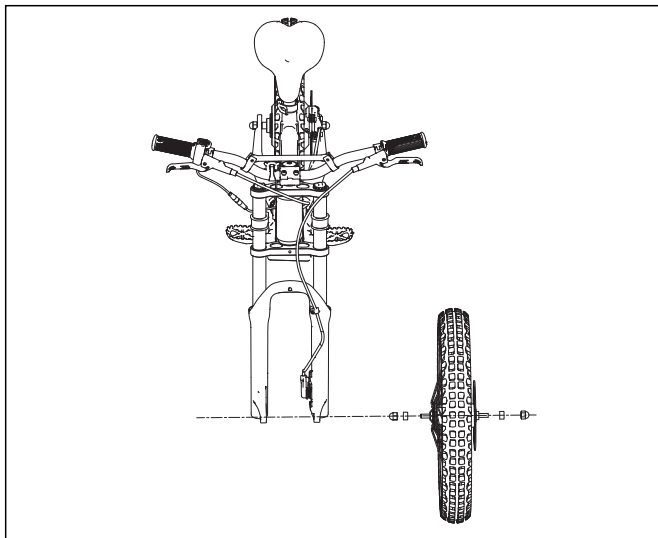
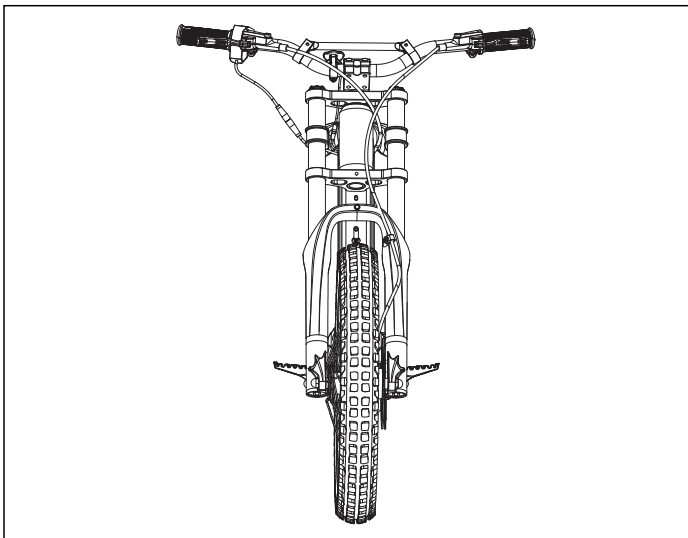

9. Wheels

9.3 Rear wheel disassembling

First, disconnect the rear hub motor and controller connectors. Pull out the rear hub motor wire from the threading hole, then use a torque wrench to loosen the fixing screws on both sides of the rear wheel. Remove the anti-drop spacers and cushions from the dropouts, lift the rear fork, and the rear wheel can be removed.

9.4 Rear wheel assembling

First, align the axles on both sides of the rear hub motor with the axle holes at the lower part of the rear fork. Insert the rear hub motor axle into the rear fork. Insert the anti-drop spacers into the dropouts on both sides of the rear fork. Thread the rear hub motor wire through the threading hole and connect it to the controller wire. Then, use a torque wrench to tighten the fixing screws with 40-45N.m force, applying thread locker to ensure they stay in place. Adjust the disc brake caliper to the appropriate state to avoid friction against the disc brake rotor or brake failure, which could be dangerous for you or third parties.

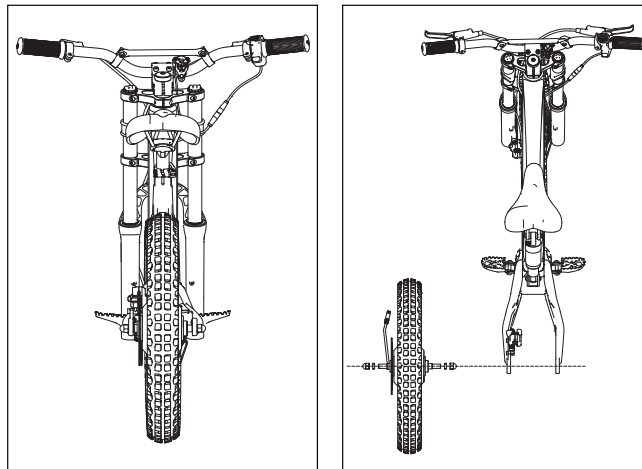

9.5 Check the condition of front and rear tires

1. Check whether there are cuts and sharp objects in the front and rear tires, if there are the above phenomena, clean up the foreign bodies or replace the tires in time.
2. Check whether the tread depth of front and rear tires meets the tread depth required by local laws and regulations.
3. Check the service life of tires. It is suggested that tires need to be replaced after more than 3 years of service, regardless of tire wear.

9.6 Check front and rear tire pressure

Remove the valve cap and measure whether the tire pressure meets the tire marking pressure. If not, repair it by inflating and deflating. After the repair, install the valve cap.

9.7 Check front and rear wheel spoke tension

When riding, if the spokes are loose, the tension of the spokes should be tested. If the spokes are loose, professionals should adjust and tighten them.

10.1 Battery remove

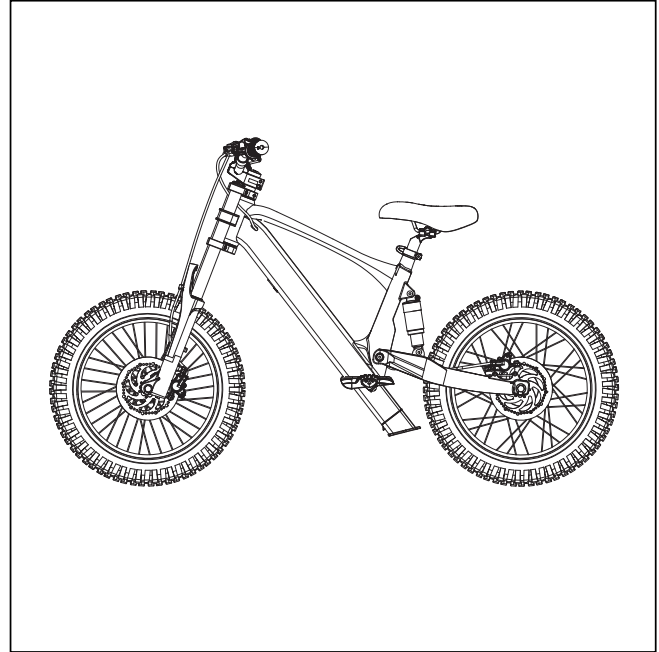
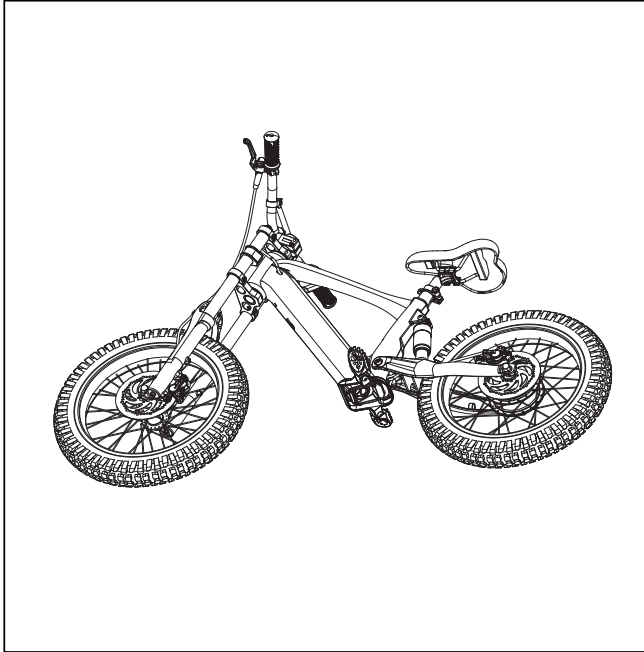

First, remove the charger on the downhill pipe, and then use your hand to move the fast disassembly wrench at the bottom of the battery, pull it to the under the frame to remove the battery.

10. Battery

10.2 Battery install

Put the battery into the frame tube with the correct direction, confirm that the lock has been buckled, the charging port is stuffed with waterproofing, and the battery is installed.

10.3 Battery charging

First connect the charger parts , remove the waterproof plug , insert the output terminal plug into the battery charging port, and the input terminal is connected to the power supply to charge the battery.

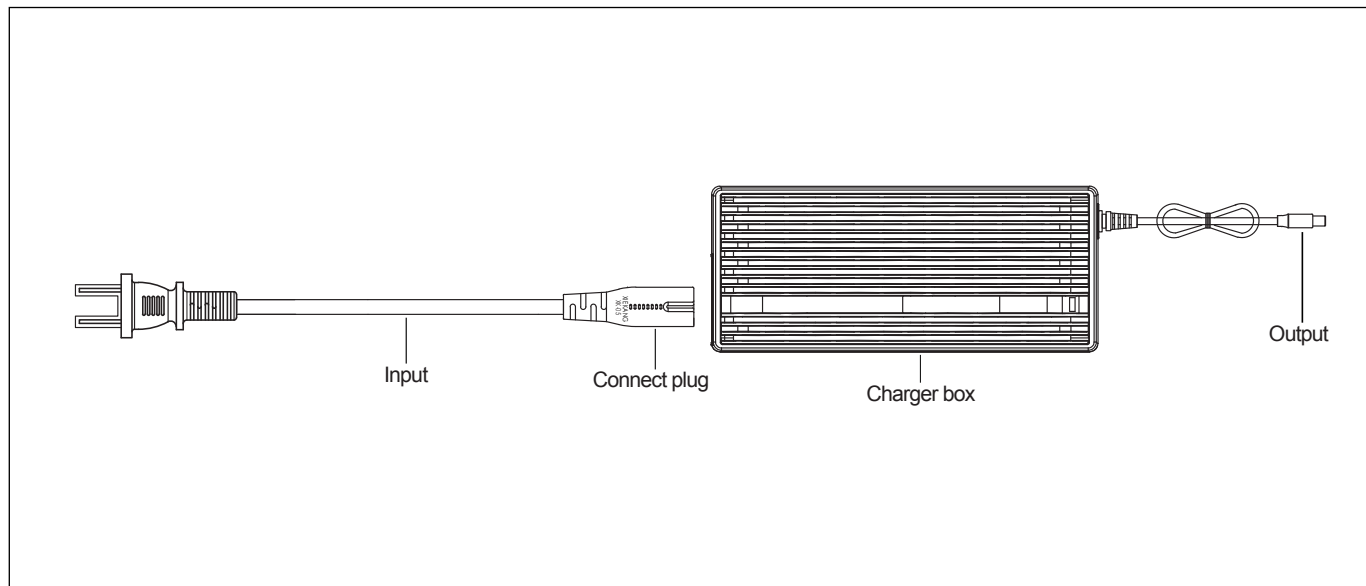

11. Chareger

11.1 Introduction to Battery Charger

Input voltage range: from 100VAC to 240VAC, single -phase input. Short -circuit protection power value: $\leq 3W$, the power supply of the power supply can return to normal work when short -circuit is lifted.

Work temperature: $0^{\circ}C \sim 40^{\circ}C$, working normally under full load conditions.

Storage temperature: $-20^{\circ}C \sim 85^{\circ}C$, with a shell.

Work humidity: $5\%(0^{\circ}C) \sim 90\%(40^{\circ}C)$, 72 hours, full load, normal work

12. Bike cleaning and maintenance

12.1 Bike cleaning procedure

1. This product can be washed with a water gun;
2. After washing, it should be dried with a towel immediately;
3. The vehicle should be cleaned and maintained promptly after use.

12.2 Related inspection and maintenance procedures

1. View whether the vehicle fastener is loosened. If there is a loose phenomenon, it is necessary to tighten them in time;
2. Whether the rear disc brakes are not good at braking when the maximum travel
3. Whether the shock absorption is insufficient after inspection. If this phenomenon exists, it is necessary to take gas increase in time;
4. Check whether there is a scratch or sharp object the tires. If it exists, it is necessary to repair or replace the tire in time.

13. Storage and reuse instructions

13.1 Storage specification

When you are not preparing to ride this product for a period of time, you should store this product in a dry and ventilated place. You should not place this product under the outdoor open -air conditions to prevent rainwater from corrosion of the car body.

13.2 Prepare riding instructions after storage

After you are preparing to cycling for a period of time, you should conduct a vehicle inspection in accordance with the 2.1 / 2.2 / 2.4 instructions, and then ride after the inspection is correct.

14. Electrical troubleshooting

14.1 Battery troubleshooting

Test whether the battery voltage is within the standard range.(26V-42V)

14.2 Display troubleshooting

When the battery is normal, the instrument display screen is bright, and the instrument is not faulty. If the instrument is not bright, it may be the instrument or controller failure.

14.3 Controller troubleshooting

When there is no failure of the battery and instrument, if the motor can operate normally, the controller is normal. If the motor does not turn, it may be a motor or controller failure.

14.4 Motor troubleshooting

If the battery, instrument, and controller are all functioning without fault, rotate the throttle. If the motor operates normally, the motor is fine. If the motor does not turn, then the motor is faulty.

If any of the above faults occur, please contact the dealer promptly for repair.

14.5 Throttle Power Cannot Be Switched On or Off

Use a multimeter set to the continuity setting to test whether the temperature line is short-circuited with the phase line. If it is continuous, it indicates a short circuit, and the motor is damaged; the motor should be replaced first and then the controller to avoid damaging the new controller. If it is not continuous, there is no problem with the motor, and the customer only needs to replace the controller.

15.1 Manufacturer's warranty and warranty

Parts item	Warranty time	Replenishment
Frame	36 months	The warranty time is calculated from the product label time
Battery	15 months	
Controller	12 months	
Motor	12 months	
Charger	12 months	
Maintenance list		
Maintenance part	Maintenance cycle	Replenishment
Tyre	3 months	Perform gas replenishment to tire identification air pressure
Lock screw	12 months	Add lubricating oil
Rear shock absorber	6 months	Inflating to 140psi
Battery	6 months	Stay for 6 months charging maintenance
Brake pads	6 months	Remove cleaning and replacement

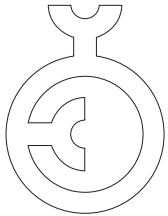

GERMAN
DESIGN
AWARD
WINNER
2024

All-Terrain Electric Moto
Enlightenment Mentor