

CLASSIC DESIGN **ITALIA**

KITCHEN

Ispirata alle imponenti architetture di culto mesoamericane che le conferiscono un'estetica iconica e razionale, nasce la prima linea di cucine dedicate all'outdoor. La struttura è realizzata in metallo Zinco Magnesio, alluminio ed acciaio inox, con speciali verniciature per esterni adatte alle alte temperature.

La matericità del piano è ottenuta dall'impiego di grandi lastre in gres dall'effetto cemento che, con la luce, evidenziano la maestosità di un oggetto dal carattere quasi rituale.

Il risultato è un prodotto che esprime l'eleganza di un design ricercato, che allo stesso tempo garantisce la durevolezza e la qualità delle prestazioni.

Il tutto completamente Made in Italy.

Tikal permette di vivere "un'esperienza" che nasce dall'insieme di qualità, condivisione e funzionalità.

Inspired by the majestic Mesoamerican architectures, which lend it an iconic and rational appearance, the first collection of outdoor kitchen is born.

The structure is made of zinc magnesium metal, aluminium and stainless steel, with special outdoor paintings suitable for high temperatures. The materiality of the surface is due to the use of large sheets of gres with a concrete effect which, thanks to the light, enhance the majesty of an almost ritual object.

The result is a product which expresses the elegance of a refined design and ensures longlasting and high quality performances. And it's all made in Italy.

Tikal gives you the chance of experiencing quality, sense of sharing and functionality.



Tikal - base 3 moduli + modulo lavello + modulo barbecue + modulo piano cottura. Optional piano snack + penisola.

Tikal - base 3 modules + sink module + barbeque module + hob module. Optional snack bar + peninsula.





Tikal - cucina 3 moduli + modulo scaffale 120x190 con pensile e modulo scaffale 80x190 con mobile base.
Tikal - 3 modules kitchen + shelf module 120x190 with suspended cabinet and shelf module 80x190 with base cabinet.



Tikal - cucina 2 moduli + moduli colonna 77x190.
Tikal - 2 modules kitchen + column modules 77x190.





14 **Tikal** - base 2 moduli + modulo lavello + modulo barbecue. Optional piano snack.
Tikal - base 2 modules + sink module + barbeque module. Optional snack bar.





Tikal - base 2 moduli + modulo lavello + modulo barbecue. Optional piano snack.

Tikal - base 2 modules + sink module + barbeque module. Optional snack bar.



Tikal - base 3 moduli + modulo lavello + modulo barbecue + modulo piano cottura.

Tikal - base 3 modules + sink module + barbeque module + hob module.



Tikal - base 2 moduli + modulo lavello + modulo barbecue.

Tikal - base 2 modules + sink module + barbeque module.



Magnesit

Gres 9 mm

Glass-ceramic
4mm

Brushed
stainless steel

COMPOSIZIONE BASE 3 MODULI - ASSEMBLY OF A BASE WITH 3 MODULES

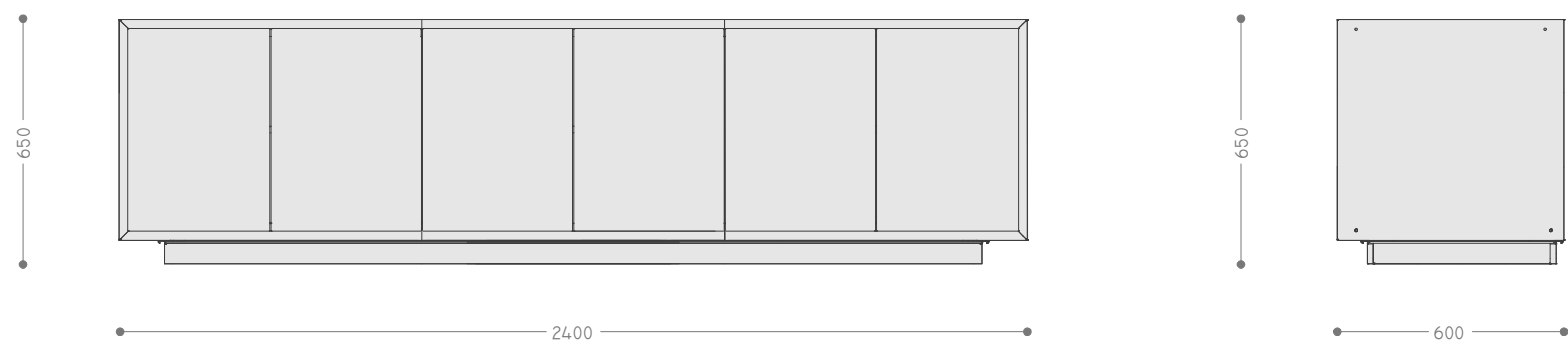

Struttura in acciaio zinco magnesio e alluminio (Magnesit), verniciatura nero RAL 9004 alte temperature testurizzato.
6 ante a battente con maniglia ad incasso gola, apertura 125° a sgancio rapido e chiusura blumotion.
Misure 2400x600x650 h - peso 140 kg.

*Structure in zinc magnesium steel and aluminium (Magnesit), black RAL 9004 high temperature, textured painting.
6 swing doors with recessed handles, fast release 125° opening and blumotion latch.
Dimensions: 2400x600x650 h - weight 140 kg.*

COMPOSIZIONE BASE 2 MODULI - ASSEMBLY OF A BASE WITH 2 MODULES

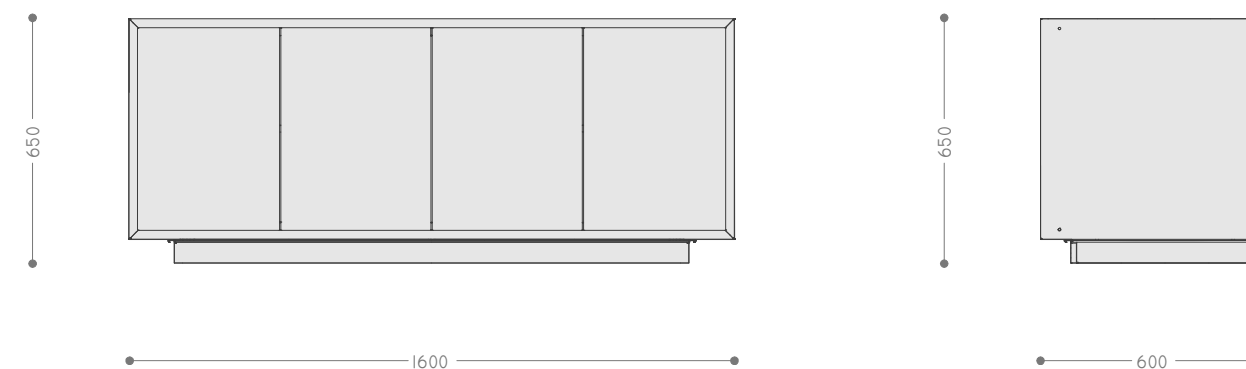

Struttura in acciaio zinco magnesio e alluminio (Magnesit), verniciatura nero RAL 9004 alte temperature testurizzato.
4 ante a battente con maniglia ad incasso gola, apertura 125° a sgancio rapido e chiusura blumotion.
Misure 1600x600x650 h - peso 95 kg.

*Structure in zinc magnesium steel and aluminium (Magnesit), black RAL 9004 high temperature, textured painting.
4 swing doors with recessed handles, fast release 125° opening and blumotion latch.
Dimensions: 1600x600x650 h - weight 95 kg.*



Modulo Barbecue

Struttura in acciaio alluminato/acciaio inox, verniciatura nero RAL 9004 alte temperature testurizzato.
 Bruciatori a Gas con potenza totale 6 kw con sistema a irradiazione Fire Core esclusivo che sfruttando abbinamento tra speciali bruciatori e deflettori che agiscono per irradiazione, permette di avere una temperatura uniforme su tutta la superficie con caratteristiche di bassi consumi ed efficienza sviluppata dai bruciatori da 2kw.
 Misure 800x600x250 h - peso 52 kg.

Barbeque module

*Aluminium/Stainless steel structure, black RAL 9004 high temperature, textured painting.
 6kw total potency gas burners with exclusive irradiance Fire Core system, based on the combined use of special burners and deflectors, which allows the maintaining of a stable temperature all over its surface. The system is characterised by low consumption and efficiency, guaranteed by 2kw burners.
 Dimensions 800x600x250 h - weight 52 kg.*

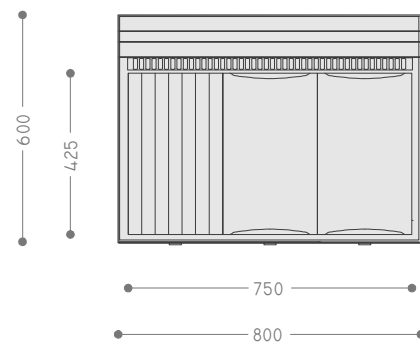

Modulo Piano cottura ad induzione

4 Zone cottura da 1800/3000 W
 Potenza massima assorbita regolabile a 5 livelli (2.8 kW / 3.5 kW / 4.5 kW / 5.8 kW / 7 kW)
 Funzione Booster - 2 zone Bridge
 Vetroceramica nero sp 4mm
 Misure 800x600x250 h - peso 39 kg.

Induction hob module

*4 cooking zones 1800/3000 W
 Maximum power input adjustable to 5 levels (2.8 kW / 3.5 kW / 4.5 kW / 5.8 kW / 7 kW)
 Booster function - 2 Bridge zones
 4 mm glass-ceramic
 Dimensions 800x600x250 h - weight 39 kg.*

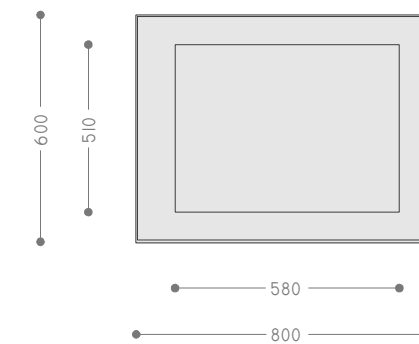

Modulo Lavello

Vaschetta (Foster) in acciaio inox AISI 304 - Sottotop
 Finitura spazzolato - 1 vasca 340x400 mm
 Miscelatore monocomando per lavello con canna piatta girevole.
 Flessibili di alimentazione F3/8".
 Finitura acciaio inox.
 Misure 800x600x250 h - peso 37 Kg.

Sink module

*Stainless steel AISI 304 sink (Foster) - Undermount sink
 Brushed finish- 1 basin 340X400 mm
 Single-lever sink mixer, flat swivel spout. 3/8" female connection hoses.
 Stainless steel finishing.
 Dimensions 800x600x250 h - weight 37 kg.*

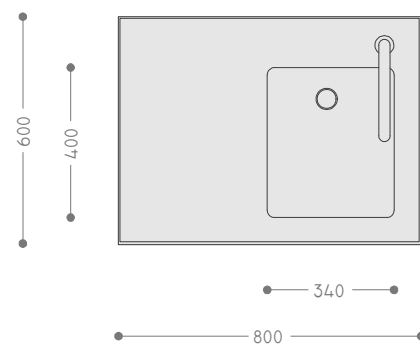

Modulo piano lavoro

Modulo neutro con piano in gres spessore 9 mm colore effetto cemento.
 Misure 800x600x250 h - peso 34 kg.

Neutral countertop module

*Neutral module with gres top 9 mm thick concrete effect color.
 Dimensions 800x600x250 h - weight 34 kg.*

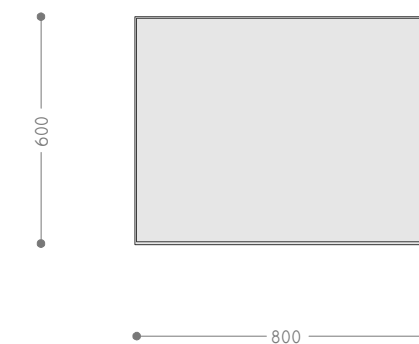

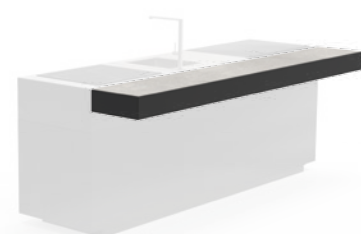

Snack

Piano a sospensione con top in gres
misura disponibili:
1600x350x130 - peso 30 kg, cucina 2 moduli
2400x350x130 - peso 48 kg, cucina 3 moduli

Snack bar

Hanging kitchen gres top:
dimensions 1600x350x130 - weight 30 kg, 2 modules
dimensions 2400x350x130 - weight 48 kg, 3 modules

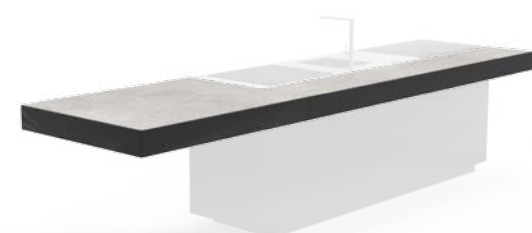

Penisola

Piano a sospensione con top in gres
misure 1200x950x130 - peso 54 kg

*abbinabile solo allo snack e disponibile solo
alla base 3 moduli

Peninsula

Hanging gres top dimensions 1200x950x130 - weight 54 kg

**only compatible with the snack and just available in the
base with 3 modules*

Base angolo con piano lavoro

base chiusa con piano in gres spessore
9 mm colore effetto cemento
misura 600x600x900 - peso 75 kg

*La base angolo non è predisposta per l'applicazione di
penisola o snack. Utilizzabile esclusivamente come
connessione tra basi 2 moduli o basi 3 moduli.

Corner base with neutral countertop

*closed base with gres top 9 mm thick concrete
dimensions 600x600x900 - weight 75 kg*

**The corner base is not suitable for peninsula or snack bar and
can be used as a connector between bases with 3 modules
or bases with 2 modules*



Cantina

Capacità: 25 litri - 8 bottiglie
Temperatura regolabile da 8°C a 18°C. Schermo LED
Funzionamento termoelettrico, sistema antivibrazione
4 ripiani in legno.

Wine cellar

*Volume capacity: 25 liters-8 bottles
Adjustable temperature from 8°C to 18°C. LED Screen
Thermoelectric functioning, anti-vibration system
4 wooden shelves.*



Frigorifero mini bar

Capacità volume 25 litri
peso netto 12 kg

Minibar fridge

*Volume capacity 25 liters
Net weight 12 kg*



Ice maker

Capacità di produzione giornaliera: 12 kg
Capacità vassoio d'acqua: 2.1L
Ciclo di produzione: 10 a 13 minuti
2 formati di ghiaccio potenza: 150W

Ice maker

*Daily production capacity: 12 kg
Water tank capacity: 2.1L
Production cycle: 10 to 13 minutes
2 ice power formats: 150W*

Modulo scaffale 120x190

Struttura in acciaio zinco magnesio e alluminio (Magnesit),
verniciatura nero RAL 9004 alte temperature testurizzato.
Scaffale con mensole metalliche removibili e regolabili.
misure 1220x1900x350 - peso 50 kg

Shelf module 120x190

Structure in zinc magnesium steel and aluminium (Magnesit),
black RAL 9004 high temperature, textured painting .
Shelf with removable and adjustable metal shelves.
dimensions 1220x1900x350 - weight 50 kg

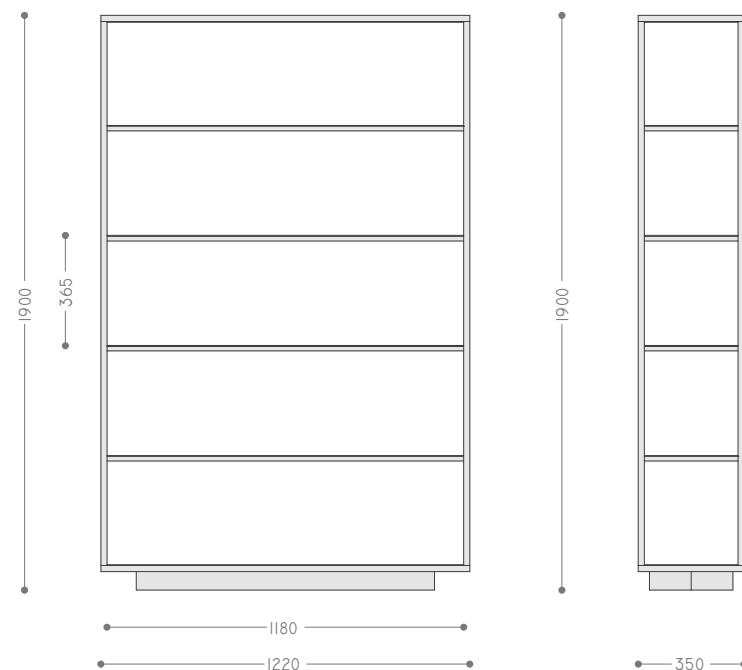
**Modulo scaffale 80x190**

Struttura in acciaio zinco magnesio e alluminio (Magnesit),
verniciatura nero RAL 9004 alte temperature testurizzato.
Scaffale con mensole metalliche removibili e regolabili.
misure 800x1900x350 - peso 40 kg

Shelf module 80x190

Structure in zinc magnesium steel and aluminium (Magnesit),
black RAL 9004 high temperature, textured painting.
Shelf with removable and adjustable metal shelves.
dimensions: 800x1900x350 - weight 40 kg

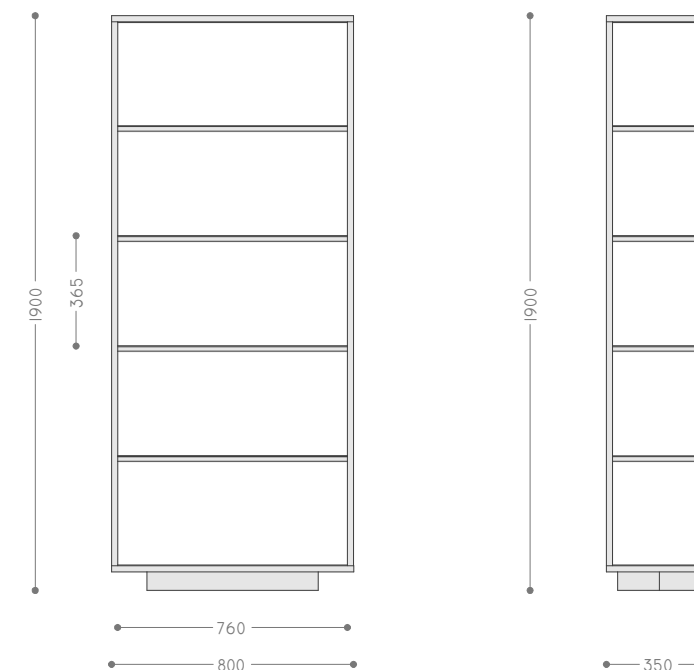
**Pensile con anta a ribalta 118x36**

Struttura in acciaio zinco magnesio e alluminio (Magnesit),
verniciatura nero RAL 9004 alte temperature testurizzato.
Anta a ribalta con maniglia ad incasso gola,
apertura 107° e chiusura blumotion.
misure 1180x365x350 - peso 20 kg

*abbinabile solo al modulo scaffale 120x190

Suspended cabinet with flap door 118x36

Structure in zinc magnesium steel and aluminium (Magnesit),
black RAL 9004 high temperature, textured painting.
Flap door with recessed handles, 107° opening and blumotion latch.
dimensions 1180x365x350 - weight 20 kg

*only compatible with shelf module 120x190

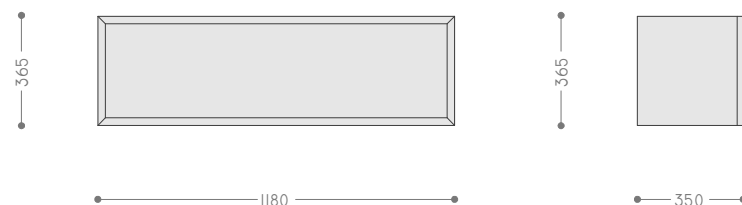
**Mobile base 76x72**

Struttura in acciaio zinco magnesio e alluminio (Magnesit),
verniciatura nero RAL 9004 alte temperature testurizzato.
Anta a battente con maniglia ad incasso gola, apertura 125° a
sgancio rapido e chiusura blumotion.
misure 760x700x350 - peso 25 kg

*abbinabile solo al modulo scaffale 80x190

Cabinet base 76x72

Structure in zinc magnesium steel and aluminium (Magnesit),
black RAL 9004 high temperature, textured painting.
Swing door with recessed handles, fast release 125° opening
and blumotion latch.
dimensions 760x700x350 - weight 25 kg

*only compatible with shelf module 80x190

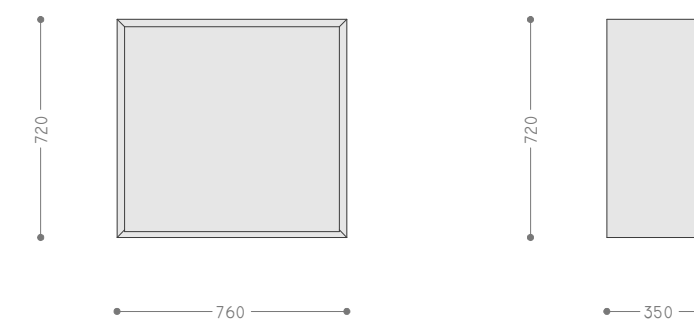

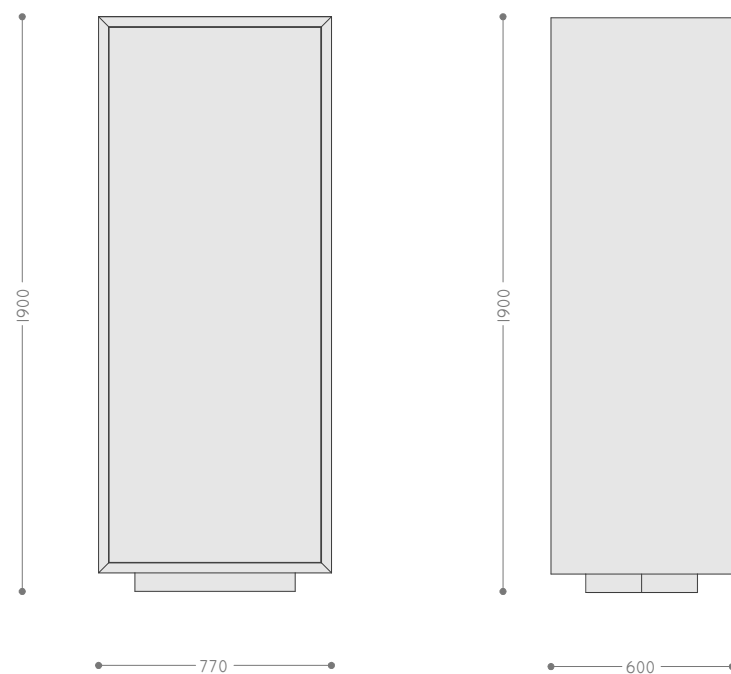

Modulo colonna

Struttura in acciaio zinco magnesio e alluminio (Magnesit), verniciatura nero RAL 9004 alte temperature testurizzato. Colonna con mensole metalliche removibili e regolabili. Anta a battente con maniglia ad incasso gola, apertura 125° a sgancio rapido e chiusura blumotion. misure 770x600x1900 - peso 90 kg

*possibilità di inserire elettrodomestici:
frigorifero (596x550x860), lavastoviglie (600x600x820)

Column module

Structure in zinc magnesium steel and aluminium (Magnesit), black RAL 9004 high temperature, textured painting. Column with removable and adjustable metal shelves. Swing door with recessed handles, fast release 125° opening and blumotion latch. dimensions 770x600x1900 - weight 90 kg

*possibility of including appliances:
fridge (596x550x860) dishwasher (600x600x820)

Led

Optional kit illuminazione a led, nascosto dal battiscopa, ip 65 luce calda 3000K, alimentazione 220w. Telecomando con dimer di intensità di illuminazione. Disponibile per base 2 moduli, base 3 moduli, base angolo, moduli scaffale e modulo colonna.

Led

Optional led lighting kit, hidden by skirting board, ip 65 warm light 3000K, 220w power supply. Remote control with lighting intensity dimer. Available for base with 2 modules, base with 3 modules, corner base, shelf module and column module.