

# TECHNICAL EDUCATION LOOM

## Technical Manual



### **AVL LOOMS**

AVL Looms, Incorporated  
2360 Park Avenue, Chico, California 95928-8305  
Phone: 530-893-4915 Fax: 530-893-1372 [www.avlusa.com](http://www.avlusa.com)  
[sales@avlusa.com](mailto:sales@avlusa.com) [support@avlusa.com](mailto:support@avlusa.com)



# Loom Manual

## Loom Specifications

<b>EQUIPMENT</b>	Model Number	Compu-Jacq3G
	Name	Technical Education Loom (TEL)
<b>SAFETY</b>	Certification	CE (EN 55011, EN 61000-6-1)
	Emergency Stops	2 buttons; Activation by either button. Activation stops rapier movement. Red lit when activated; green light unlit. Pull button to deactivate and return to normal machine operation (red unlit, green lit).
	Safe-Start	Jog mode start-up when rapier and drive not at home
	Interference Avoidance	Position sensors on rapier, beater and lift system disallow unsafe shed and rapier movement
	Pinch Points	Steel and polycarbonate panels and coverings
	Electrical	Secured steel panels
	Warnings	Pinch point, shock, hot surface and emergency stop decals
<b>FRAME</b>	Type	TEL, black powder coat
	Structure	Steel, 1in x 2in tubular
	Gantry	Integrated with structure
	Leveling	Adjustable feet, non-slip pads (6)
	Foot Print	38.1in (96.8cm) W x 68.0in (172.7cm) D
	Overall	60.0in (152.4cm) W x 109.0in (276.9cm) D x 105.5in (268.0cm) H
<b>OPERATING ENVIRONMENT</b>	Classification	Class B - Light Industrial, indoor
	Temperature Range	50°F - 104°F (10°C - 40°C)
	Humidity Range	10% - 90 % Relative Humidity
	Ventilation/Cooling	None required
<b>FLOOR BRACING</b>	Type	Flat Concrete, 2,500 PSI (176 KG/cm) min. compressive strength
	Concrete Insert for Mounting Bolt	1 per side, HILTI drop in expansion anchor (or comparable)
	Bolt for seismic bracing bracket	1 per side, ½”-13 x 1” grade 5 hex bolt (or comparable grade metric hex bolt)



# Loom Manual

## Loom Specifications (continued)

<b>ELECTRICAL INPUT</b>	Connection	2 – 15ft (4.6m) electrical cords, 3-Wire (Live, Neutral, Ground), direct wire to plant
	Protective Earthing	Through electrical cord ground wire
	Supply Voltage Range	2 - 220-240 VAC, single phase, 50-60 Hz
	Maximum Current Draw	Line 1 (upper): 18.3A Line 2 (lower): 10.7A
	Current Rating at On/Off Breakers	Line 1 (upper): 20.0A Line 2 (lower): 15.0A
	Circuit Protection	UPS recommended
<b>EXTERNAL ELECTRICAL CIRCUITS</b>	Power Input Cord Circuit Rating	12AWG, 25A, 300V max
	Motor Circuit Rating	22 AWG, 5A, 300V max
	Cloth Advance Sensor Circuit Rating	22 AWG, 300V max
	Beater Position Sensor Circuit Rating	26 AWG, 500V max
	Brake Circuit Rating	20 AWG, 300V max
<b>DATA INPUT</b>	Connection	USB 2.0
	Data Cable	10ft. (3m) USB 2.0 Male A / Male B
	PC (customer supplied)	Windows XP – 8; USB port; Mouse
	Control Software	JacqPoint ver. 2.0
<b>NOISE</b>	Maximum Sound Power Level Produced	69db

## Equipment Lamp/Light Condition Indicators

<b>COLOR</b>	<b>MEANING</b>	<b>APPLICATION</b>	<b>EXPLANATION</b>
RED	Emergency	Emergency stop. Initiation of emergency function	Actuate in case of hazardous condition or emergency
GREEN	Normal	Tool functioning properly	Actuated when power applied, breakers on and emergency stops deactivated



# Loom Manual

## Loom Specifications (continued)

<b>PATTERN</b>	Mechanism	AVL 3 <sup>rd</sup> generation Jacquard, Jacq3G™
	Jacquard Configuration	10 modules W x 120 hooks D (1,199 total hooks)
	Density	150 EPI (cast out for lower density)
	Shedding Mechanism	AVL E-Lift™ (stepper motor)
	Heddle	Inserted eye, nickel plated, cinch-top, 400mm x 1080R Spring attachment, molded plastic
	Electronics	Compu-Jacq™ control, USB 2.0 input
	Jacq3G special features	Easy-Access module support frame Positive airflow minimizes fiber contamination
	Control computer	Customer-supplied, MS Windows XP-10
	Control Software	JacqPoint ver. 2.0
	Computer table	12in (30.5cm) W x 36in (91.4cm) D x 36in (91.4cm) H Engineered wood, black melamine wrapped Steel, black powder coated
<b>WEFT</b>	Delivery	Single color rigid rapier (stepper motor)
	Storage	Spool, 4.0in (10.2cm) Dia. x 4.0in (10.2cm) W
	Tension	Single yarn tensioner, adjustable
	Spool Control	Drag, adjustable
<b>WARP</b>	Delivery	Tensioned Creel (customer supplied)
	Input Guide	Rollers (2), controls warp height Open top raddle, controls warp width
	Output Guide	Fixed bars (2), controls warp height
	Advance	Automatic electronically programmable or manual, 0.001-5 PPI
	Output clamping	Adjustable clamp with SmoothGrip™ surface
	Fabric removal	Adjustable clamp with SmoothGrip™ surface
	Fabric storage table	Integrated cloth clamp table, 9.9in (28.1cm) W x 35.5in (90.2cm) D Engineered wood, black melamine wrapped Steel, black powder coated
<b>BEATER</b>	Type	Bottom swing, rigid aluminum construction
	Pivot	Roller ball bearing
	Reed	12 DPI x 8in W x 5in H
	Controls	SHED and RAPIER activation buttons



# Loom Manual

## Tools and Spare Parts

<b>P/N</b>	<b>DESCRIPTION</b>	<b>INCLUDED WITH LOOM</b>
SLEY-10	Heddle threading hook	1
SLEY-S	Reed sleying hook	1
N/A	Weft tensioner threader	1
ALEN-1/4	1/4" Allen wrench	1
ALEN-26566	1/8" Allen wrench	1
ALEN-26570	5/32" Allen wrench	1
ALEN-26572	3/16" Allen wrench	1
ALEN-2MM	2mm Allen wrench	1
ALEN-82615	9/64" Allen wrench	1
N/A	Drive programming cable, STAC6-SI	1
N/A	Seismic bracket (set of two with mounting hardware)	1
J3G-MOD-M019	Jacq3G hook	20
HDL-400x1080R-LANCIA	Jacquard Heddle, 1080R inserted eye, Lancia top	20
SPR-SPAM-65/90	Spring 65/90, D0.025, 11.0" Jacq	20
SOL-RG-03UA-B01	Solenoid, Jacq3G assembly	10
J3G-MOD-CBL-D001	Drive cable	5
TEL-COMB-25A, Q2-09-MS500FT, Q2-F3X-1/16-01-MS100FT, HH3SS	36" comber cord with HH3SS hook assembly	10



# Loom Manual

## **Overview**

This manual provides technical specifications, feature reviews and notes on operation and maintenance for Technical Education Loom (TEL). The loom was developed for the purpose of training new technicians for production of three dimensional, non-conductive technical fiber fabrics and parts.

## **Intended Use**

The TEL provides a training platform that allows the student to participate in the weaving process, seeing and directly experiencing the effects of pattern, interlacement, beat up and fabric advancement. Being a manual loom, all processes are slowed sufficiently for easy observation, and thus optimal understanding.

The primary technologies incorporated into the loom are:

- Electronic Jacquard pattern selection
- Electronic shed lift
- Electronic rapier weft placement
- Electronic fabric advancement

The TEL is designed for use with non-conductive yarns. Use of conductive yarn or fiber in or around the loom could damage the equipment.

In normal operation, all secured panels must stay closed and secured. Only qualified AVL personnel should open panels.



# Loom Manual

## Before Getting Started

Please read the entire manual before using the loom.

### **Warnings:**

**WARNING: EQUIPMENT SHOULD ONLY BE USED FOR TEXTILE MANUFACTURING. IF THE EQUIPMENT IS USED IN A MANNER NOT SPECIFIED BY THE MANUFACTURER, THE PROTECTION PROVIDED BY THE EQUIPMENT MAY BE IMPAIRED.**



**WARNING: ELECTRICAL SHOCK HAZARD. DO NOT TAMPER WITH ELECTRICAL WIRES OR OPERATE THE LOOM WITH SAFETY PANELS OPENED OR REMOVED.**



**WARNING: PINCH, CRUSH, AND FINGER CUT-OFF HAZARDS. DO NOT OPERATE THE LOOM WITH SAFETY PANELS OPENED OR REMOVED. DO NOT PLACE HANDS IN MOVING MECHANISMS OR SCISSORS.**



# Loom Manual



WARNING: HOT SURFACE. DO NOT TOUCH



ATTENTION: EMERGENCY STOP. PRESS TO STOP RAPIER MOVEMENT. PULL TO RETURN TO NORMAL OPERATION.





## Loom Manual



**WARNING: EQUIPMENT PANELS ARE AWKWARD AND HEAVY. TO AVOID MUSCLE STRAIN OR INJURY, USE PROPER LIFTING TECHNIQUES AND A HELPER.**

**WARNING: SECURED PANELS ARE TO BE REMOVED ONLY BY AN AVL TECHNICAL REPRESENTATIVE.**

**WARNING: DO NOT POSITION EQUIPMENT IN A WAY TO BLOCK OR IMPEDE ACCESS TO DISCONNECTING DEVICES, EMERGENCY STOPS, OR ON/OFF BREAKER SWITCHES**

**WARNING: USE OF CONDUCTIVE FIBER OR YARN ON OR AROUND THIS EQUIPMENT WILL VOID WARRANTY AND MAY DAMAGE EQUIPMENT.**

**WARNING: THIS EQUIPMENT IS CLASSIFIED FOR LIGHT INDUSTRIAL ENVIRONMENT ONLY. OPERATION OF HIGH-CURRENT DRAW EQUIPMENT (EX. MIG WELDER) ON THE SAME ELECTRICAL CIRCUITS MAY CAUSE EQUIPMENT FAILURE.**



# Loom Manual

## Safety Features:

The loom contains several safety features designed to avoid injury and equipment damage. These include:

- 1) Electrical lockout switches stop electricity flow to loom.
- 2) Safety labels draw attention to danger areas. Do not reach under a panel while the loom is powered.
- 3) Green light prominently displays that the loom is powered and On/Off Breakers are switched on. Light extinguishes when power is removed, Breakers are off, or when either or both emergency stop buttons are pressed.
- 4) Panel secured with fasteners. Behind the main panels are high voltage and the more extreme pinch dangers.
- 5) Panel hinges allow for opening and access without removal of large, heavy equipment panels.
- 6) Covers and shielding separate weaver from moving components where pinch hazards exist. Do not reach under a covers and shielding while the loom is operating.
- 7) Emergency stop button cuts power to the rapier motor. Activation stops the rapier from moving avoiding potential personal and equipment damage. The depressed emergency stop button lights red to notify user that the loom requires attention. The Green Power-On Lamp is deactivate when red light is on. Pull out the emergency stop button once the danger has been addressed and to resume loom normal operation.
- 8) Beater and drive sensors disallow rapier activation unless beater is in rear-most position and drive is in open shed position.
- 9) Slow start programming is provided to enable clearing of the equipment after emergency or accidental shut down. Slow start allows small, incremental step movements of the E-Lift and rapier by pressing the respective beater button until home positions are reached. Shed lift home is the open shed position. Rapier home is the fully retracted position.



# Loom Manual

## Installation and Commissioning

### **Personnel:**

Installation and commissioning shall be performed by authorized AVL Looms personnel only.

### **Location:**

Equipment must be installed on a flat concrete floor. The concrete floor must be rated to support a minimum of 2,500 PSI compressive strength.

A 5ft (1.5m) clearance should be provided on each side of loom. Space considerations for the customer-supplied creel will include the at least 5ft (1.5m) of open space between the back of the loom and the creel, plus the creel length.

### **Connection to Plant Electrical:**

Connection of the equipment to electricity shall be performed by a qualified electrician only. The plant circuit must be rated for 208-240 VAC, 50-60Hz, single phase with line 1 at 20A and line 2 at 15A. The electrical cord provided may be either hardwired into the plant electricity or wired to a suitably rated plug for a corresponding outlet.

### **Seismic Concerns:**

Where seismic concerns exist, equipment should be installed with supplied brackets and hardware. Use HILTI drop in expansion anchors inserted into the concrete floor. Use HILTI instructions for concrete preparation and anchor installation. Use Grade 5 ½"-13x1" Fastener Bolts (or equivalent metric hardware).

### **Loom Square and Level**

The loom must be squared and leveled during installation. Squaring entails measuring diagonally, front to back, in each direction. If the measurements do not match within one-sixteenth of an inch, loom hardware is loosened and the frame is racked until the measurements match, then the frame hardware is tightened. The loom is provided with six adjustable height feet for leveling. For side to side leveling, place a level on a horizontal crossmember and adjust the feet. For front to back leveling, place a level on a horizontal sideframe member and adjust the feet. Feet adjustment may require slight jacking of the frame.



# Loom Manual

## Operation

### **Perspective:**

All discussion in this manual is presented from the weaving position at the front of the loom. The left side of the loom is to the weaver's left. The front of the loom is where the weaver stands.

### **Loom Startup/Shutdown:**

#### Startup

1. Ensure that the rapier path is clear. Flip to the ON position (I) the two power switches located on the left side panel of the control system on top of the loom.





# Loom Manual

1. Jog the rapier home by pressing and holding the right button (RAPIER) on the beater until the rapier head reaches its home position and stops moving within the housing on the right side of the loom.
2. Jog the E-Lift home by pressing and holding the left button (SHED) on the beater until the heddles reach their lowest position and stop moving.

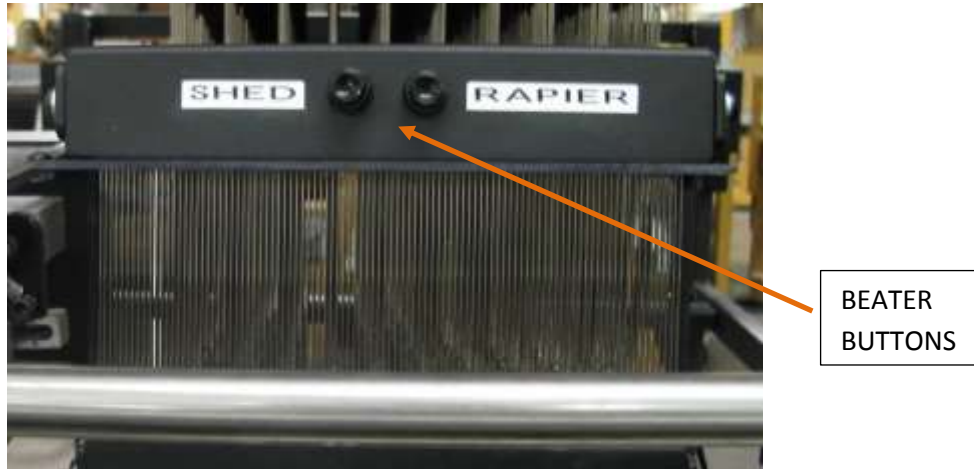

3. For JacqPoint loom control, refer to [Loom Control Steps](#) in the **Personal Computer and Software** section of this manual.

## Shutdown

1. With the rapier at home, select Null Pick in JacqPoint Loom Control window. Select the left beater button to activate the null pick.
2. Exit the Loom Control windows.
3. Flip to the OFF position (O) the two power switches located on the left side panel of the control system on top of the loom.

## **Weaving:**

Weaving is designed to be simple and easy to observe using the following steps:

- 1) The user stands at the front of the loom, on either side of the output table with one hand on the beater.
- 2) To open a shed, the user selects the left button (SHED) on the beater to activate the E-Lift. The E-Lift will momentarily move to center shed to allow hook selection, and then open the shed for weft insertion.
- 3) Once the shed is achieved, the user presses the right button (RAPIER) to activate the rapier. The rapier runs across the warp, grabs the weft yarn, activates the scissors and returns to its starting position.



## Loom Manual

- 4) The user pulls the beater forward to beat the weft yarn into the shed.
- 5) Using the left button, the user changes shed, and then returns the beater to its rear position.
- 6) The user repeats the process starting at step 3.

### NOTES:

- a) At first weft insertion, the user must pre-position the weft for the rapier. To accomplish this:
  1. The beater is pulled forward to the stops.
  2. The weft yarn is pulled from the tensioner, through the open scissor and held the end at the left side of the reed holder, which will be the fell line location. This positions the weft yarn to be grabbed by the rapier.
  3. The beater is pushed back, then the rapier is activated.
- b) Selecting and holding the left (SHED) button on the beater for a count of 15 seconds will switch shed modes. The two shed modes are:
  1. Double shed (normal operation)
  2. Single step shed (maintenance/diagnostics); Use single step when lubricating the hooks and when diagnosing hook selection issues.
- c) The loom controller will automatically shut off all solenoids after fifteen seconds of activation, which may occur in single step mode at center shed. In addition, the solenoids are automatically inactivated at open shed.

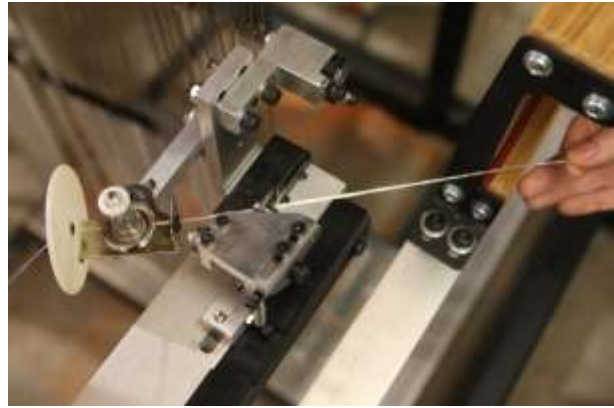



# Loom Manual

## Weaving Settings:

### Cloth Advance Introduction

The cloth advance system is designed to achieve three goals:

- 1) Smooth, even fabric advancement
- 2) Managed warp/fabric tension
- 3) Consistent fell-line position

Its capabilities include: manual and automatic operation, wide range of distance and speed settings, advance/no advance on a per pick basis, and high strength drive for advancing up to 750 lbs. of warp force.



The programmable automatic cloth advance consists of three primary components:

- 1) Linear drive coupled electronic stepper motor
- 2) Man-Machine Interface (MMI)
- 3) JacqPoint setting



# Loom Manual

## Cloth Advance Operation

The electronic stepper motor and drive are controlled through the MMI, JacqPoint selection and embedded limit sensors.



*MMI and MMI Menu Button*

- 1) To access the MMI, press the MMI Menu button to the left of the MMI. The home screen will change to the first selection menu.
- 2) Select the 4 key on the MMI to access 'Parameters'. Parameters define the distance and speed of linear drive movement for automatic cloth advance, manual advance and retreat (1:ADV and 2:RET). The distance range can be set between 0.0001 and 5 inches. The speed can be set between 1 and 20 revolutions/second. Press enter after each parameter selection. To determine your desired distance simply invert your desired picks per inch. The speed setting will require experimentation to determine the optimal setting for your weaving.











# Loom Manual



*Parameters Menus*

- 3) Select 1 'Adv' to move the cloth clamp one pick's distance away from the beater.
- 4) Select 2 'Ret' to move the cloth clamp one pick's distance towards from the beater.
- 5) Select 3 'Jog' for faster movement of the cloth clamp. The Jog selection input screen will be displayed on the MMI.

- a. Press the  key to advance the  cloth clamp (move away the beater). Press the key again to stop movement, or allow the linear drive to reach its end limit sensor.
- b. Press the  key to retreat the cloth  clamp (move towards the beater). Press the key again to stop movement, or allow the linear drive to reach its home limit sensor.



- 6) Select 5 'Exit' to exit the MMI menu and weave in automatic cloth advance mode.
- 7) JacqPoint selection of pick by pick advance activation is done by selecting/de-selecting hook #1200. When the hook is selected for activation on a pick, the linear drive will advance the cloth clamp by the distance and speed selected in the MMI Parameters menu.



# Loom Manual

## NOTES:

- When either the home or end limit sensor switch is reached, the linear drive will no longer move the cloth clamp. However, the weaver may continue weaving (opening sheds and using the rapier to lay-in the weft).
- When the end limit sensor is reached, the MMI screen notifies the weaver of the limit.
- Weaver must manually move the cloth clamp back to the home position for tie-on.

## Rapier Extended Position:

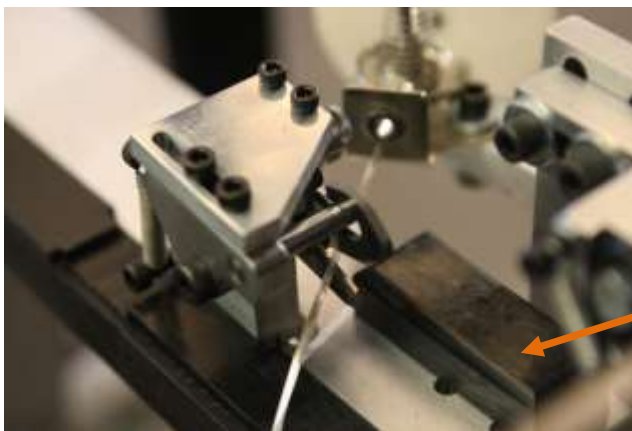

RUBBING BLOCK

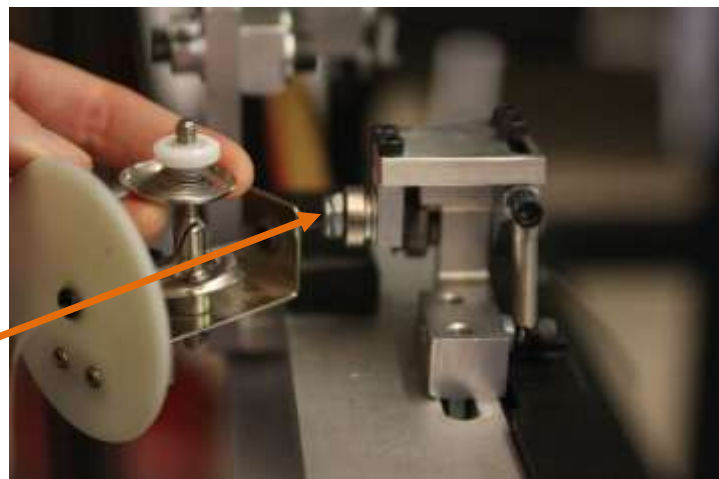

DOG

A stationary rubbing block and spring-loaded dog are located near the extended position to squeeze open the rapier head gripper in order to capture the weft yarn. In setting rubbing block/dog positions, first adjust the block such that the head very lightly rest on it. Then, adjust the dog to open the gripper sufficiently to allow the weft yarn slide into the gripper. The head should move past the dog, thus fully gripping the weft yarn, before intersecting with the scissor bearing.



# Loom Manual

## Rapier Home Position:

Rapier position settings are set at the factory.

Rapier home position is in the fully retracted position. The rapier home position sensor lights when not triggered. With the rapier fully retracted, position the sensor right at the point where the sensor light turns off.

Two stationary rubbing blocks, one each above and below where the head sits when in home position, are positioned to squeeze open the gripper for releasing the weft yarn. In setting rubbing block positions, first adjust the lower block such that the head very lightly rest on it. Then, adjust the upper rubbing block to open the gripper just enough to release the weft yarn just before the rapier reaches home.

## Rapier Gripper Tension:

Gripper tension is set by loosening the lock screw on the front side of the rapier head, tightening or loosening the bolt on top of the rapier head, and then tightening the lock screw. The gripper tension should be set





# Loom Manual

## Rapier System:

The rapier position is set at installation. The critical settings for the rapier are

- Level travel
- Consistent 1/8 inch spacing from the reed as head moves across
- Rapier nose point just above center line

With the loom unpowered, manual move the rapier for measuring these settings. Adjust position with the system hardware.

## Scissor Position:

The scissor is activated when the rapier head moves onto the scissor head rubbing block. Scissor positioning is set at the factory. Adjusting the scissor position requires moving the bearing in line with the rapier head. The height of the bearing defines the amount of arc in the scissor movement, where a lower setting equates with more arc.

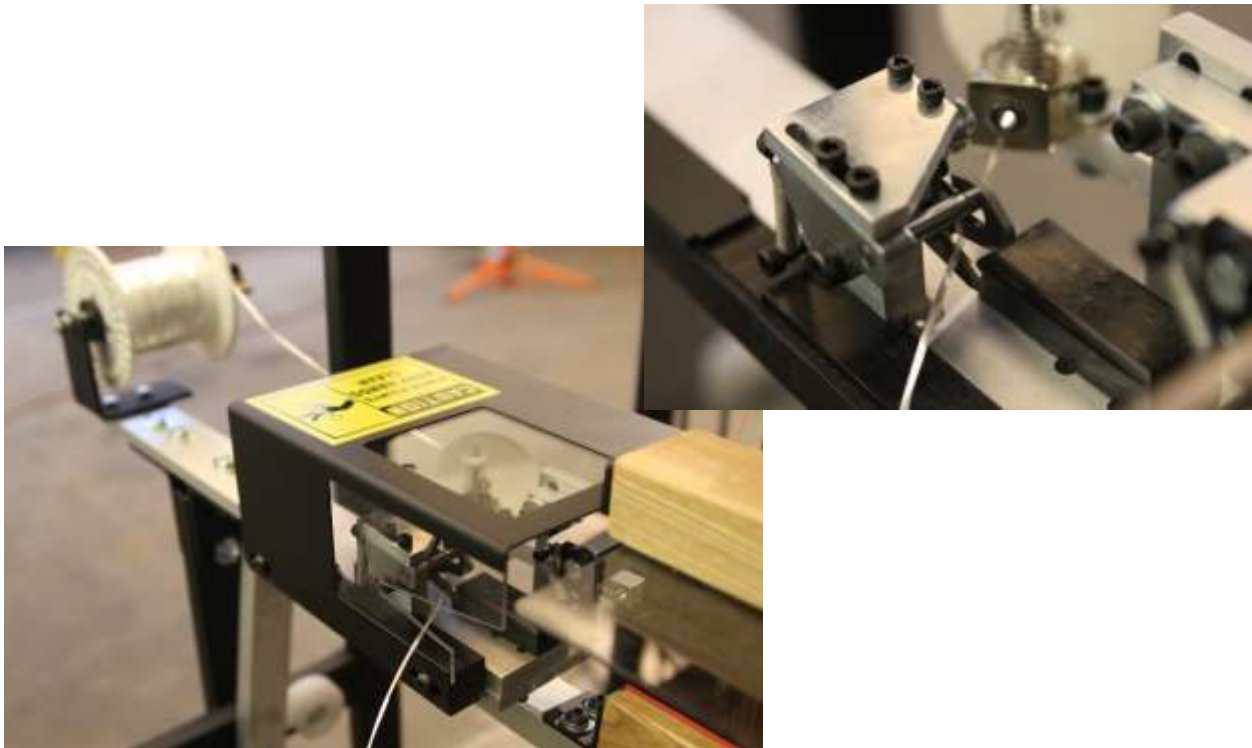



# Loom Manual

## Weft Spool Tension:

Weft is wound onto a customer supplied five (5) inch spool. To avoid free-spinning of the weft spool, tighten the tri-knob while turning the spool. *Warning: Over tightening the spool tension may cause issues with rapier operation.*



## Weft Tensioner:

The weft tensioner provides adjustable tension by the nut on top of the spring. Tighten the nut to increase tension. Tension should be set with the minimal amount of tension required to achieve the two divergent goals of avoiding

- Yarn slack between the tensioner and scissor, and
- Yarn pulling out of the gripper.

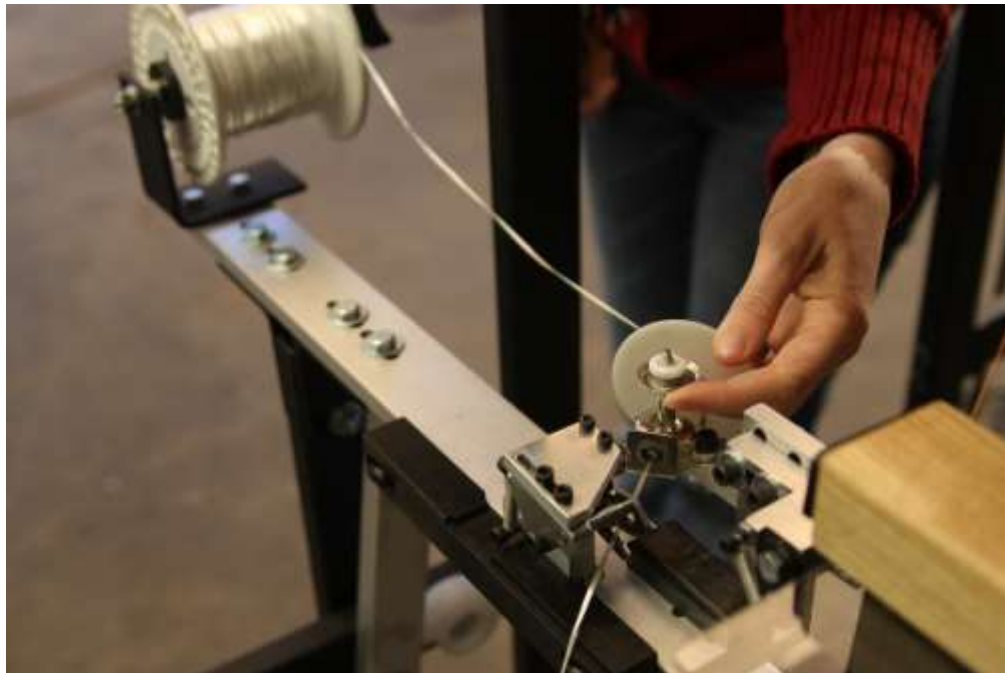



# Loom Manual

The weft tensioner brackets allow for proper positioning to achieve the two goals:

- Yarn is level and at the same height as the center line
- Yarn passes through scissor opening in a line between the tensioner exit hole and the fell line

## Personal Computer and Software:

Loom operation requires the customer to supply a MS Windows®-type computer with one available USB port (ver. 1.0, 1.1, 2.0 or 3.0). The loom comes with

- 1) JacqPoint MS Windows-based loom control software
- 2) USB 2.0 cable, 10 foot, A male - B male

### Loom Control Steps:

- 1) Start JacqPoint.
- 2) Power up the loom.
- 3) Open a weaving file.
- 4) From the **Weave** menu, select **Jacquard Options...**

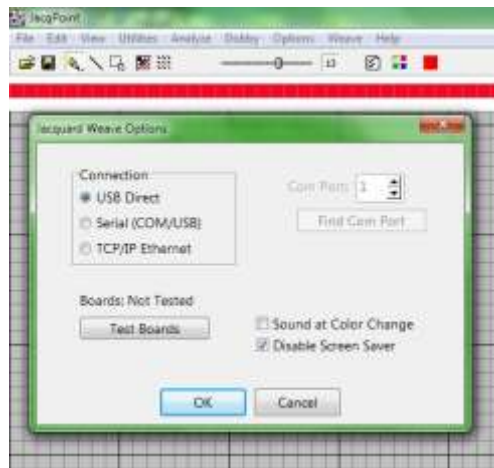

- 5) Select **USB Direct**, then select **Test Boards** from the dialog box. A new dialog box will appear displaying the status of the connection, and once cleared another dialog box will appear showing the status of the module testing.
- 6) Upon successful completion, select **Loom Control** from the **Weave** menu. Input the appropriate start and end picks is necessary and begin weaving.



# Loom Manual

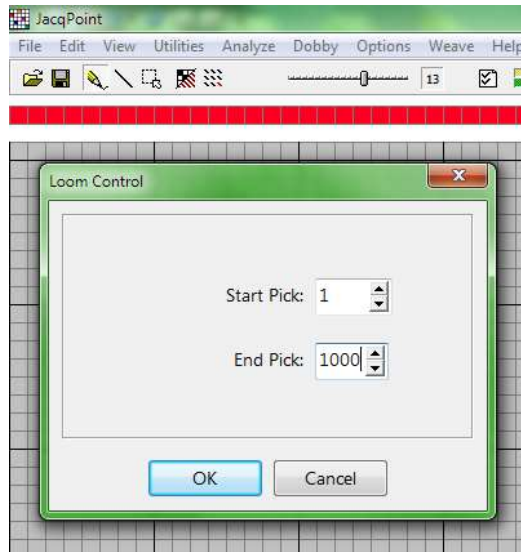

- 7) To complete weaving and shutdown, select **Null Pick** from the AVL Jacquard control window, open the new shed, then select **Close** from the AVL Jacquard control window. The loom and Macbook are now ready for powering down.

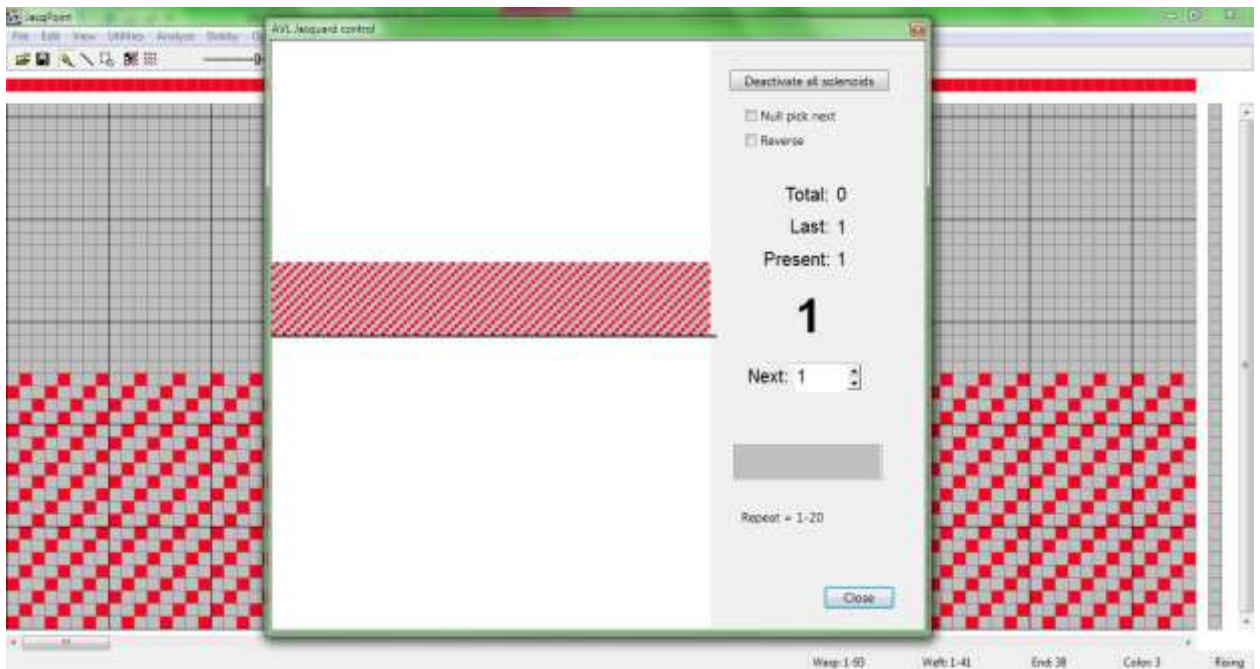

## NOTES:

- a) JacqPoint uses a native JCP file as the standard format. It also allows the use of BMP, PNG or J1P formats, all of which can be output by ArahWeave and most other design software.



# Loom Manual

- b) If loom connection fails, repeat Loom Control Steps including power cycling the loom.
- c) You may also use Serial (COM/USB) communication mode to connect with the loom. This mode uses a virtual serial driver instead of the direct USB driver, both of which come preloaded on the Macbook. Should you ever need to reload USB drivers, these are provided for download on the AVL ([www.avlusa.com](http://www.avlusa.com)) or FTDI (<http://www.ftdichip.com/FTDrivers.htm>) websites.

## Dressing the Loom:

This loom requires a creel (customer-provided) to supply the warp. The creel provides up to twelve hundred individually-tensioned warp threads, exiting through an eye board that ensures no crossed or twisted threads.

*The most important aspects in dressing the loom are:*

- 1) No crossed or twisted threads at any place behind or in the loom. These errors will cause mechanical issues with the hook operation.
- 2) Straight through threading without angles between the raddle/rollers and heddles. This error will cause mechanical issues with the hook operation.
- 3) Thread sizing appropriate to the density. With twelve hundred (1,200) hooks in eight (8) inches, the weaving density is very tight. Overly thick yarn will exacerbate all other problems.
- 4) No yarn abrasion (applies mostly to technical fibers). Fuzzing will affect nearby yarn, creating a snow-balling affect. If left unchecked, yarn will become unpassable through heddles and reed. If noticeable fuzzing can be seen during loom dressing, pull the yarn through until the damaged areas have passed through the pressure rollers.

## Dressing Features:

- 1) Ten (10) dents per inch raddle with removable top: Raddle at the rear of the loom organizes widely-spaced yarn from the creel eye board to the correct eight inch weaving width. Unbolt the raddle top from the frame allowing place-in threading. Place fifteen (15) ends in each raddle dent to set the maximum one hundred fifty (150) ends per inch density.







## Loom Manual

- 2) Removable rollers: Rollers bring warp yarns to the correct warp height. Pull pins to remove rollers. Replace rollers positioning a roller below and a roller above the warp.

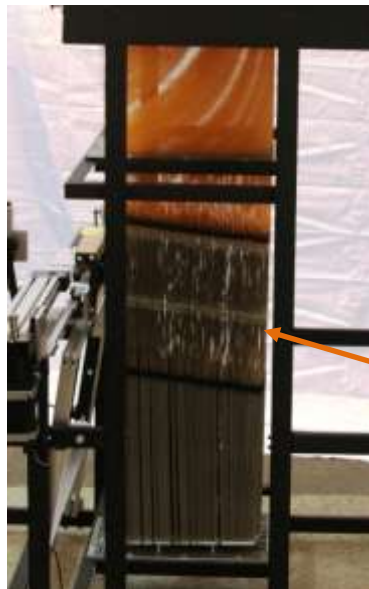
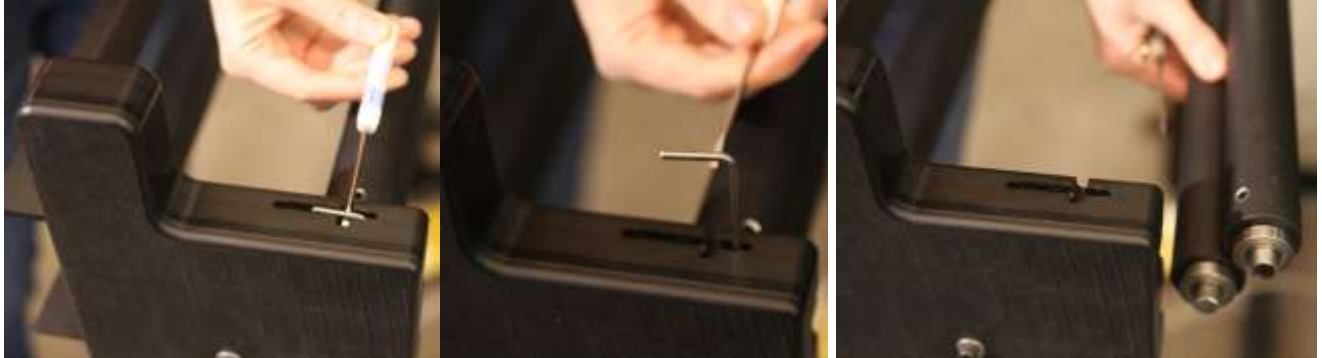

HEDDLES

- 3) Heddle position and fixture: In their fixed position, the heddles are angled to provide easier identification. Additionally, the heddle rows may be disconnected from the fixture to provide for more space during threading.
- 4) Twelve (12) Dents per Inch (DPI) Reed: Sley reed alternating between twelve and thirteen ends per dent to achieve the maximum one hundred fifty (150) ends per inch density.
- 5) Move the Cloth Advance to home position (closest to the beater). Unclamp the handles on each side and slide the clamp open. Insert warp ends from the bottom up and tension the warp before re-clamping.



## Loom Manual

- 6) Removing the woven cloth/part: The fixed clamp is provided to secure the warp during part/fabric cut-off and re-ting on. During weaving the fixed clamp is to remain open with the top hanging down away from the warp. To cut off the woven part/fabric:
  - a. Advance the linear drive to its send limit.
  - b. Swing the fixed clamp closed and clamp both sides.
  - c. Cut the warp just behind the woven fabric and open the cloth clamp to remove the woven part.
  - d. Move the linear drive to home, feed the warp into the cloth clamp, secure the cloth clamp, and then open the fixed clamp.

### Cloth Advance Clamps

The cloth advance system utilizes two clamps: cloth clamp and fixed clamp. The cloth clamp is attached to the linear motor and moves with the advance. The warp is attached to the cloth clamp during loom setup and before weaving.

The fixed clamp is left open during weaving. When the woven cloth is complete and ready to be removed from the loom, the fixed clamp holds the warp side to allow cutting of the warp and removal of the woven cloth without losing warp tension..

### Clamp Usage

Both clamps work in the same way. Both orange handles are flipped open to allow the clamp to be opened.

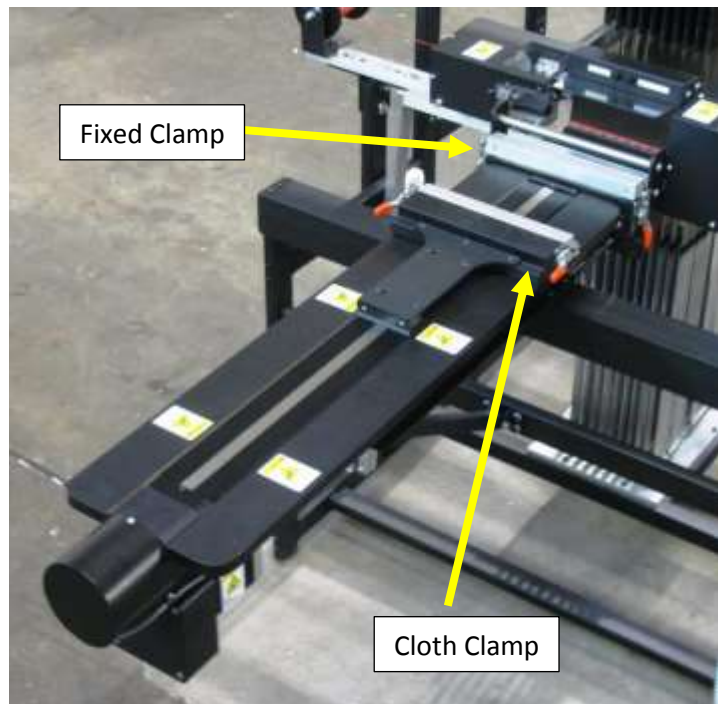

To secure warp threads, lay the threads into the open clamp then close and secure the clamp.



# Loom Manual



*Cloth Clamp Closed*



*Cloth Clamp Open*



*Fixed Clamp - Open*

*Fixed Clamp - Hanging*

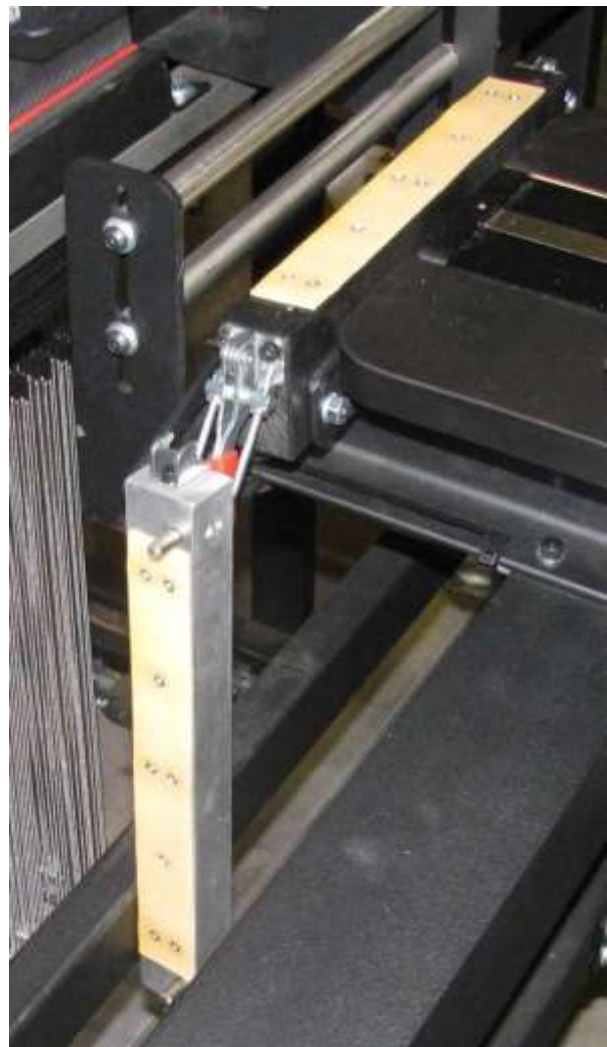



# Loom Manual

## Preventative Maintenance and Troubleshooting:

The loom requires periodic maintenance. Periodicity is determined by use, but we recommend the following as a starting point:

FEATURE	ACTION	TIMING INTERVAL
Safety equipment	Inspect and verify legibility of decals and proper operation of emergency stops.*	Six months
Drive chain	Lubricate, clear lubricant gel	Four months
Module pulley bearings	Lubricate, clear lubricant gel	Four months
Module bearings	Lubricate, clear lubricant gel	Four months
Hooks & other bare metal	Lubricate, dry lubricant spray	Four months
Hardware	Inspect and tighten	Four months
Fan filters	Vacuum or rinse in water	Yearly
Scissors	Replace	When dull
External sheet metal and frame	Clean with damp cloth	Yearly

\*Failure of Safety equipment should be immediately remedied. Contact AVL for replacement parts.

See Appendix A: Wiring Diagrams for additional information on wiring.

See Appendix B: Jacq3G Lubrication Schedule document for additional information.

See Appendix C: Jacq3G Module Troubleshooting and Adjusting Guide for additional information on adjusting modules.



*Drive Chain (Inside Control Box)*



# Loom Manual



*Module Hooks Exposed (Front Cover Removed)*

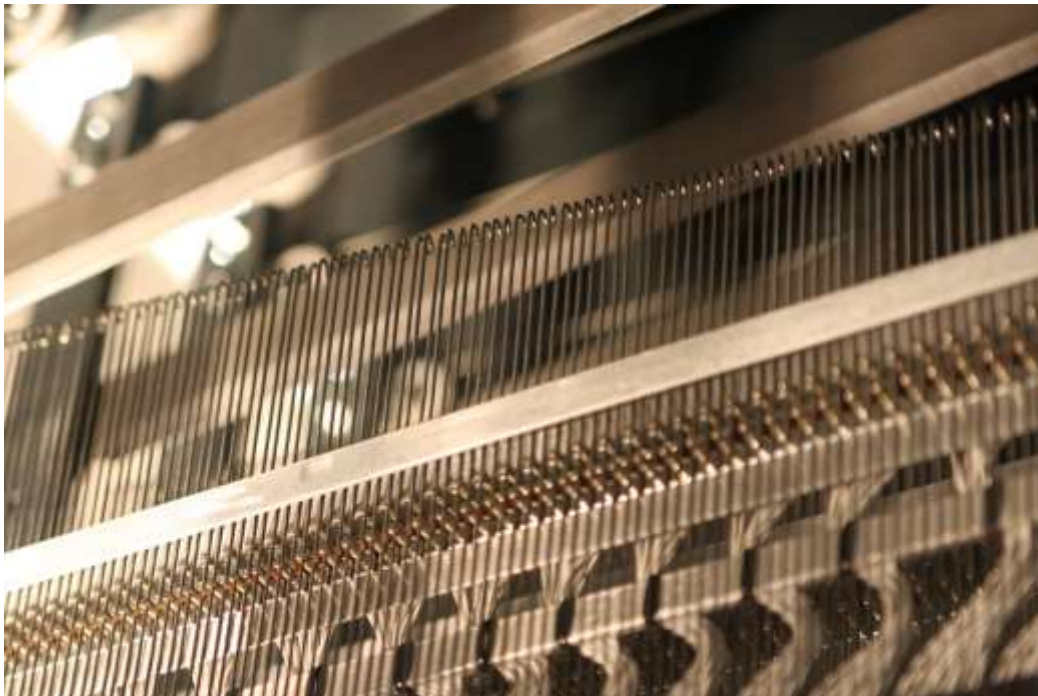

*Hooks Close Up*



# Loom Manual

## **Support Information**

For technical support, warranty claims and parts ordering, contact AVL Looms at

Email: [support@avlusa.com](mailto:support@avlusa.com), [sales@avlusa.com](mailto:sales@avlusa.com)

Phone: +1 530 893 4915

Fax: +1 530 1372

Web: <http://www.avlusa.com/resources/>

Mail: AVL Looms

2360 Park Avenue

Chico, CA 95928

## **Authorized Replacement Parts**

AVL Looms is the only authorized seller of replacement parts for this product. Use of unauthorized replacement parts voids the product warranty.

## **Warranty Information**

AVL Looms, Inc., a California corporation (“AVL”) warrants to the original purchaser of any AVL loom (each, a "Product") that the Product will be free from defects in materials and workmanship during the limited warranty period described herein. The limited warranty coverage begins (a) the day the Product is installed if installed by a professional from AVL, or (b) on the date of shipment from AVL to the original purchaser if the Product is not installed by AVL (the “Effective Date”). Except as set forth under the section entitled “What is Excluded?” below, AVL will, for a period of one (1) year from the Effective Date (the “Original Warranty Period”), repair or replace the defective part(s) of the Product with a repaired, renewed, or comparable part (whichever is deemed necessary or proper by AVL) if it becomes defective or inoperative or fails to perform according to AVL’s specifications. Any repair during the Original Warranty Period will be carried out without charge to you for parts (except applicable taxes, if any). You will be responsible for all labor in connection with installation of the parts and service upon the Product, as well as the cost of shipping involved.

Software Media: Subject to the limitation contained in subsection (i) under the section entitled “What is Excluded?” below, AVL warrants to the original purchaser of any physical diskette (or downloaded software) and documentation (“Software Media”) that is sold by AVL that such Software Media will be free from defects in materials and workmanship for ninety (90) days from the date of purchase. In the event that the Software Media is physically damaged or physically defective and if such defective Software Media is returned to AVL within ninety (90) days of the date of purchase, AVL will provide replacement Software Media at no charge. The sole remedy for this warranty shall be limited to the replacement of the defective Software Media. You are responsible for all shipping charges (including applicable taxes) incurred with returning the defective Software Media. To the extent any additional warranty coverage may be



## Loom Manual

available with respect to the Software Media, it is offered by the third-party manufacturer and you must contact them directly.

All New Products and their components (including replacement Product and its components) are covered only for the Original Warranty Period. When the warranty on the original Product or Software Media expires, the warranty on any replacement Product, components, or Software Media also expires. After one (1) year from the Effective Date, you pay for any replacement or repair, including all parts, all labor and shipping charges (including applicable taxes).

### **Disposal at End of Life**

Disposal of the tool, or any unit, assembly or component coming from the tool, should be done in an environmentally acceptable manner in accordance with the regulations specified by the local authorities.

### **Notice to Users in the European Union**

Products bearing the CE mark are in conformity with the protection requirements of EC Council directives 2004/108/EC, 2006/95/EC, 1999/5/EC, and 2009/125/EC on the approximation and harmonization of the laws of the Member States relating to electromagnetic compatibility, safety of electrical equipment designed for use within certain voltage limits, radio equipment and telecommunications terminal equipment and on the ecodesign of energy-related products. Compliance is indicated by the CE marking.



The manufacturer of this product is: AVL Looms, Inc., 2360 Park Avenue, Chico, CA 95928 USA. A declaration of conformity to the requirements of the Directives is available upon request from the Authorized Representative. This product satisfies the Class B limits of EN 55022 and safety requirements of EN 60950.



## APPENDIX A: WIRING DIAGRAMS

### Overview

- AC power is routed to the Lockout and into the two Filters
- From the filters the lines run into 2 breakers where they continue to the AC terminals (11-13)
- PS1,2,3,4 and 3 Drives are all connected to terminals 11-13 and Chassis ground is terminated to the frame
- The module boards are connected to the power supplies as well as the brake to PS4
- Terminals 1-8 are connected on the left side to the drive output/input header from either the Main Drive, Advance Drive or Rapier Drive
- Sensor inputs and misc. jumpers are plugged into left side of AC terminals (1-8)

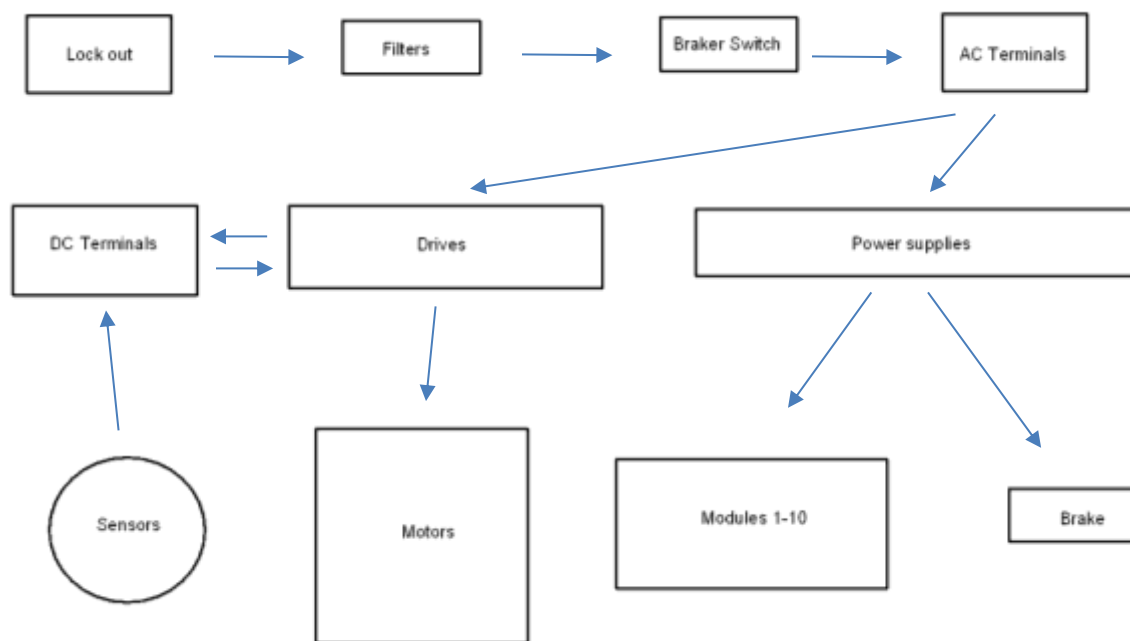





# Appendices

## APPENDIX A: WIRING DIAGRAMS (continued)

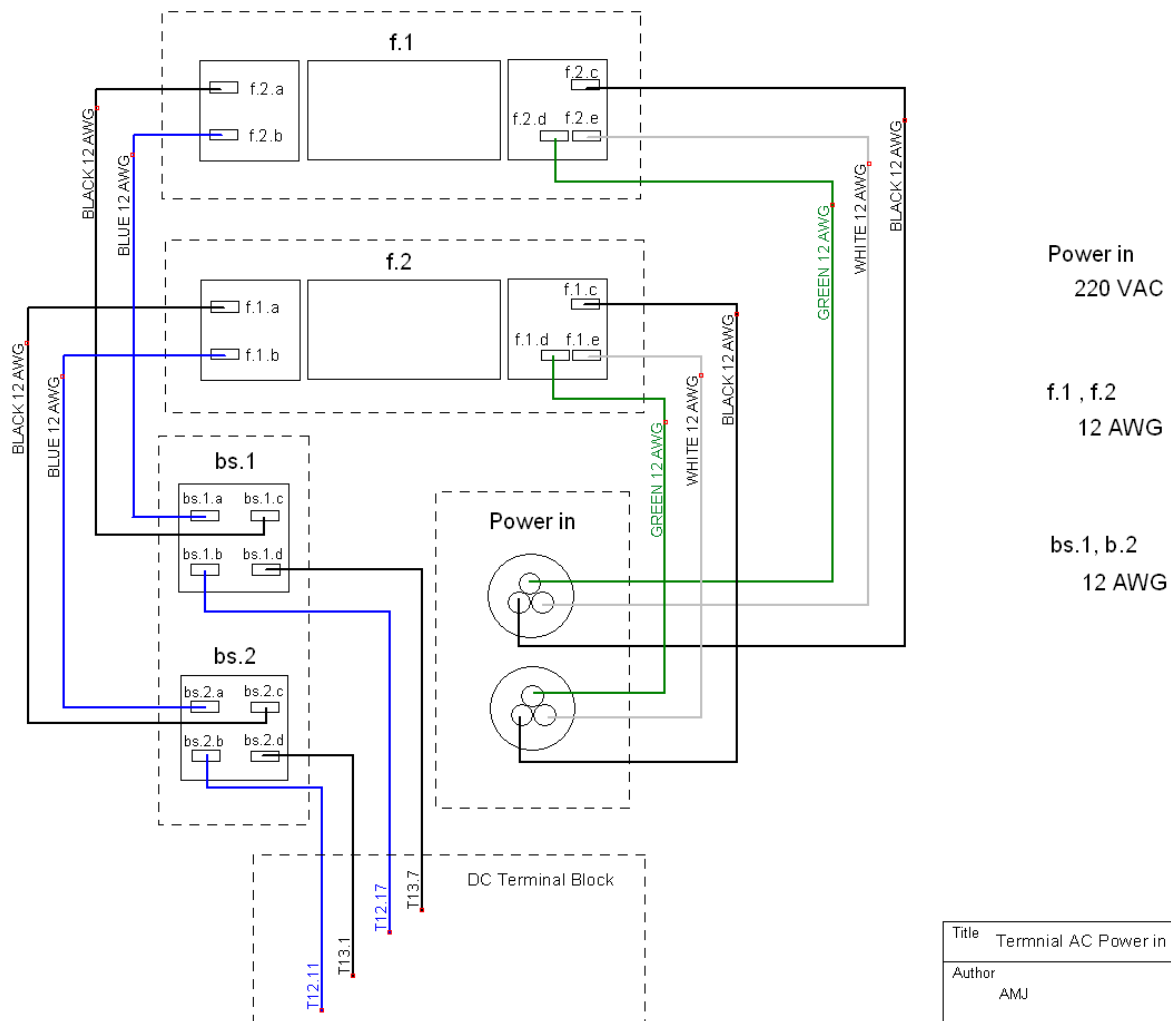

Power in  
220 VAC

f.1, f.2  
12 AWG

bs.1, bs.2  
12 AWG

Title Terminal AC Power in		
Author AMJ		
File its\TELMEXico\Current\terminal AC Power in.dsn	Document	
Revision 1.0	Date 2/1/17	Sheets 1 of 1



# Appendices

## APPENDIX A: WIRING DIAGRAMS (continued)

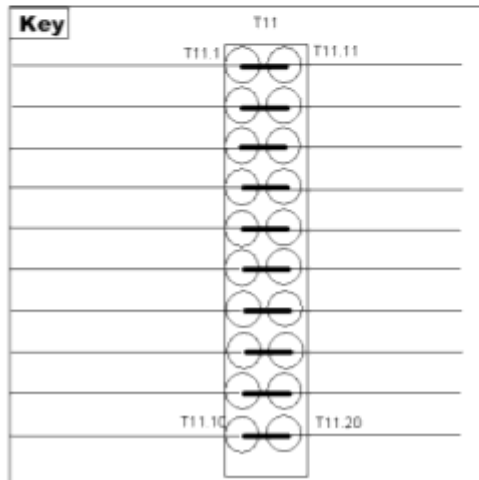
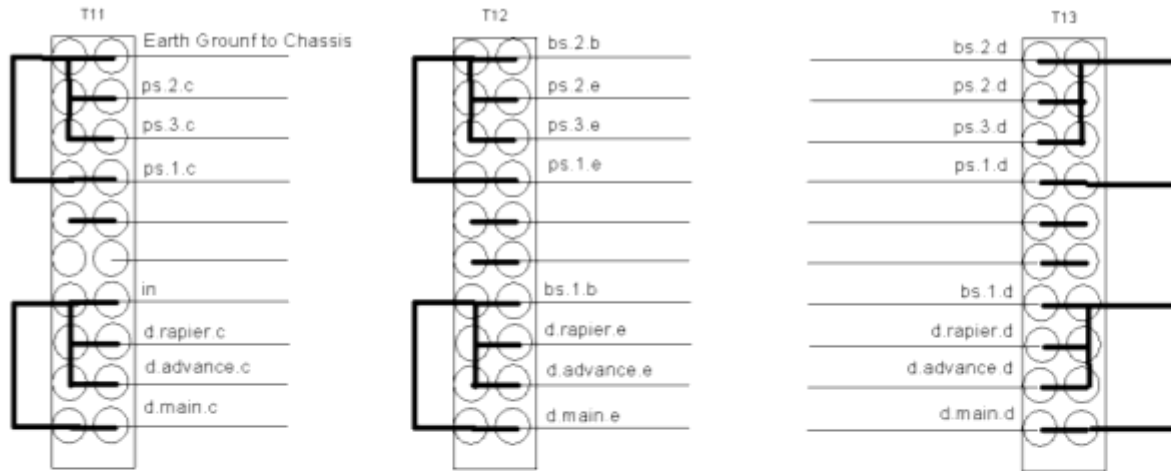

All wiring 12 AWG

Title Terminal AC 11-13		
Author AMJ		
File g:\TEL\MExico\Curent\terminal AC 11-13 V.1 dsn	Document	
Revision 1.0	Date 2/2/17	Sheets 1 of 1



# Appendices

## APPENDIX A: WIRING DIAGRAMS (continued)

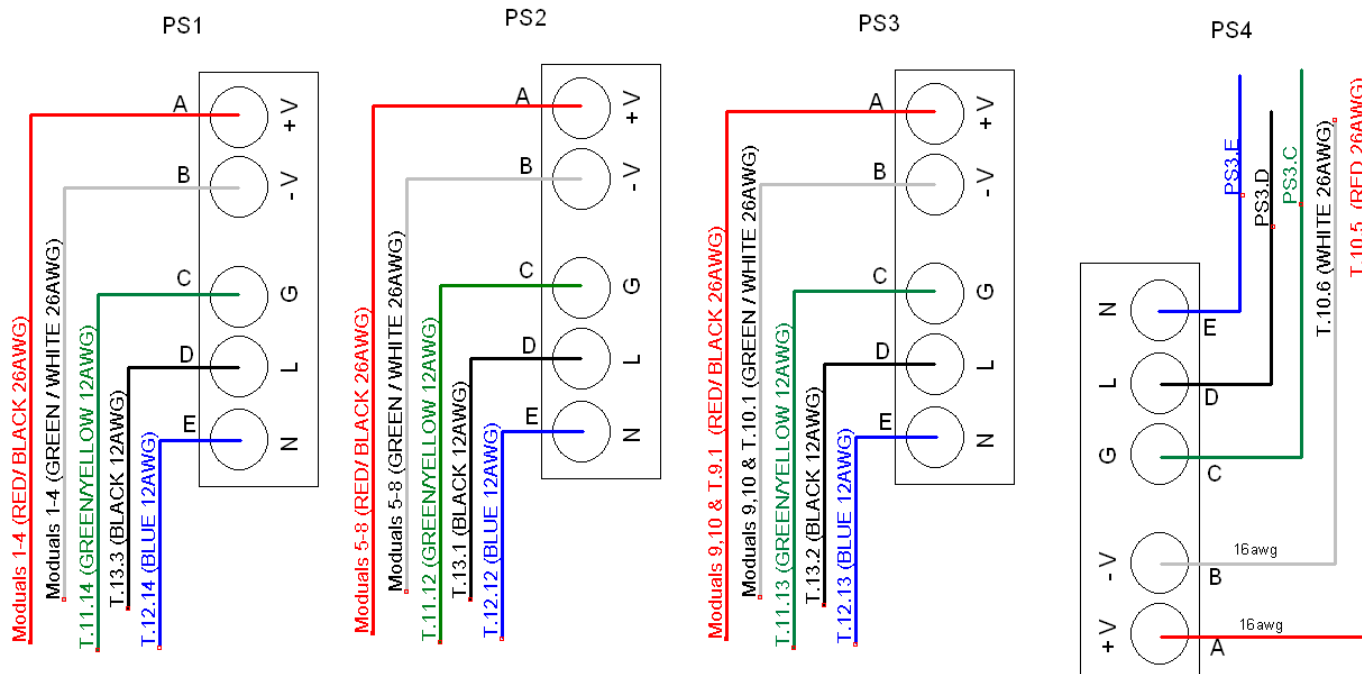

All wiring 12 AWG unless otherwise noted

Title Power supplies		
Author AMJ		
File uts\TEL\MExico\Current\Power Supplies_V.1.dsn	Document	
Revision 1.0	Date 2/2/17	Sheets 1 of 1



# Appendices

## APPENDIX A: WIRING DIAGRAMS (continued)

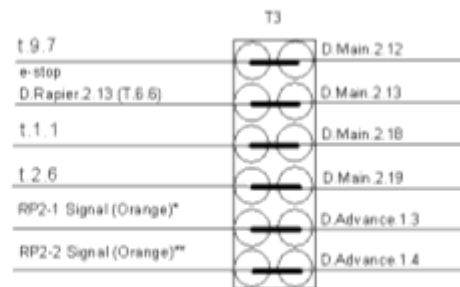
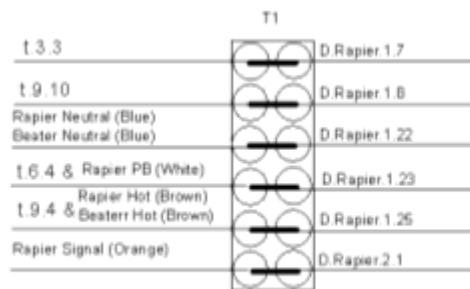

\* RP2-1 Sensor away from brake

\*\* RP2-2 Sensor nearest brake

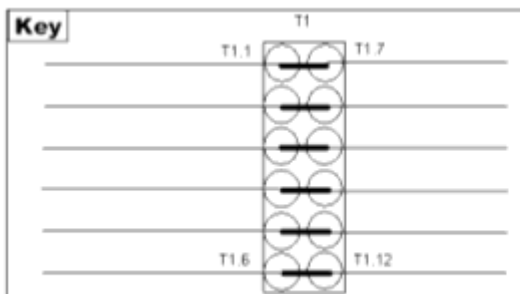
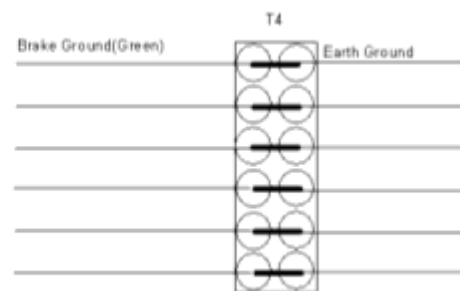
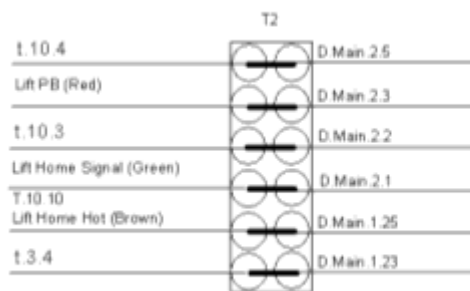

Title Terminal DC 1-4		
Author AMJ		
File h:\s\TEL\ME\ico\Current\terminal DC 1-4 V.1.dsn	Document	
Revision 1.0	Date 2/2/17	Sheets 1 of 1



# Appendices

## APPENDIX A: WIRING DIAGRAMS (continued)

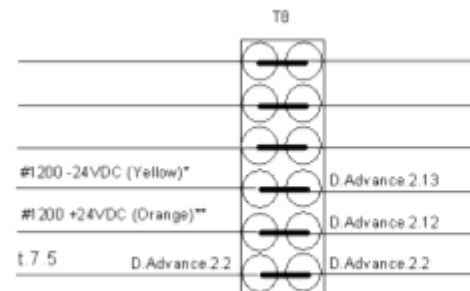
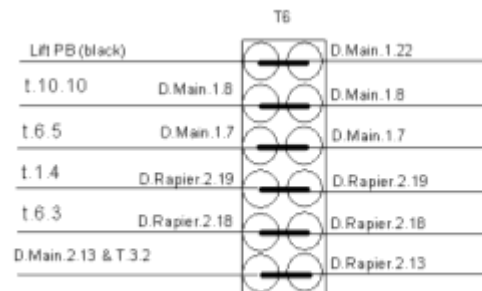
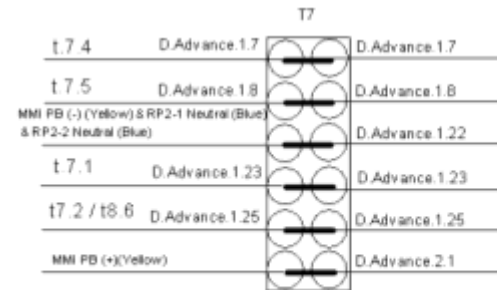
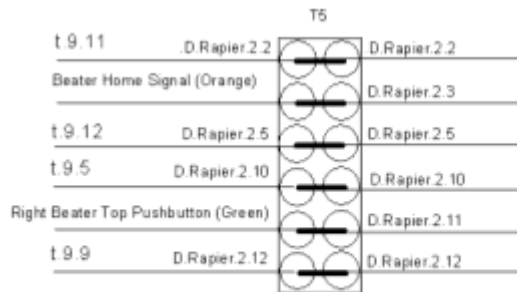

\*-24VDC On driver board is closest to board (Inner Position)

\*\* +24VDC On driver board is farthest away from board (outer Position)

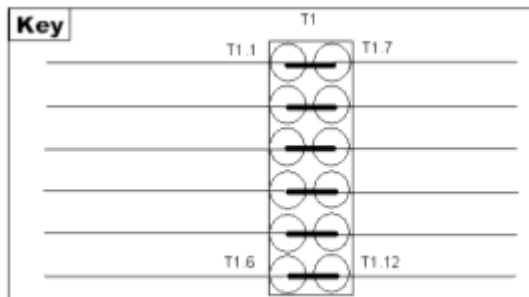

All Wire 26AWG

Title		Terminals DC 5-8
Author		AMJ
File	uts\TELME\ico\Current\terminal DC 5-8 V.1 dsn	
Revision	Date	2/2/17
1.0		Sheets 1 of 1



# Appendices

## APPENDIX A: WIRING DIAGRAMS (continued)

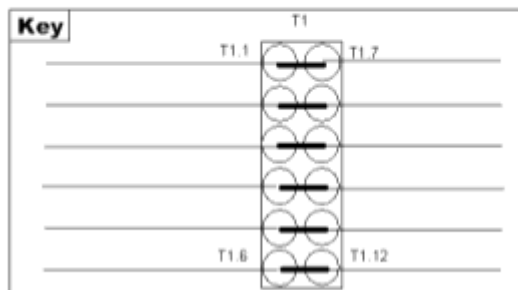
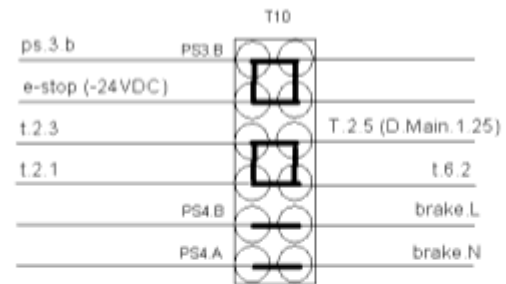
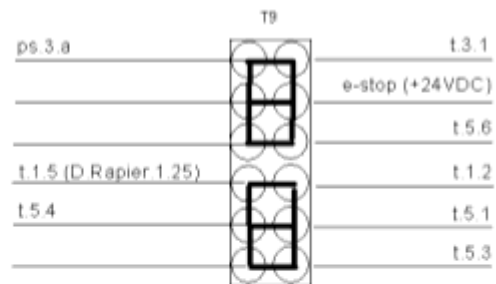

All e-stop wiring is 26AWG Orange

Title Terminal DC 9-10		
Author AMJ		
File rs\TELMEXico\Current\terminal DC 9-10 V.1.dsn	Document	
Revision 1.0	Date 2/2/17	Sheets 1 of 1



# Appendices

## APPENDIX A: WIRING DIAGRAMS (continued)

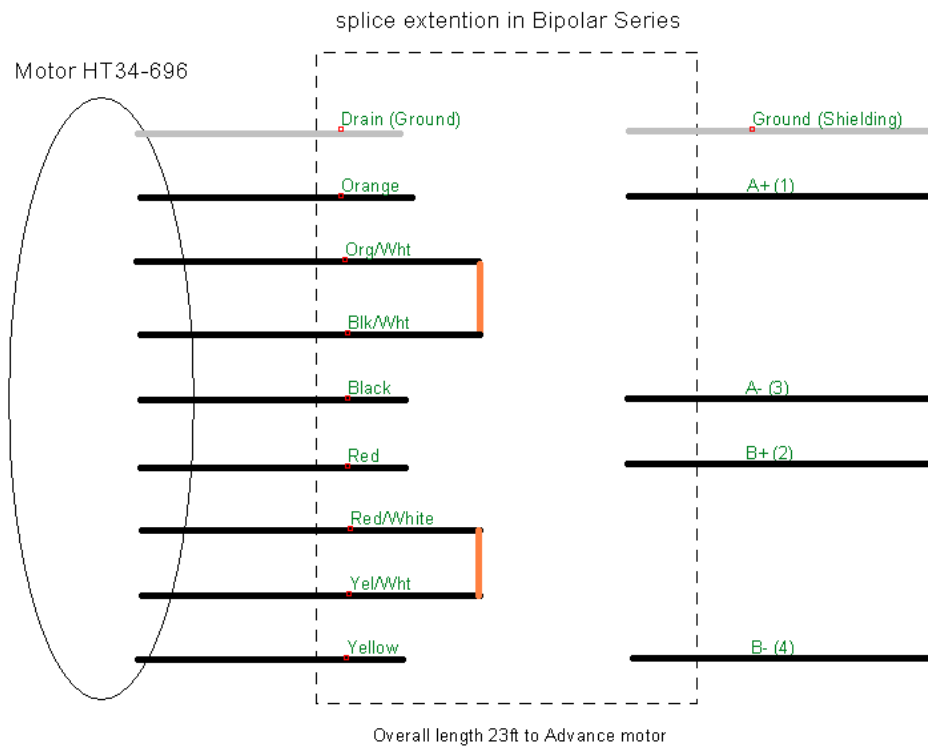

Title		
Advance Motor HT34-696		
Author		
AMJ		
File		Document
\\Exico\Current\Advance Motor HT34-696 V.1.dsn		
Revision	Date	Sheets
1.0	2/2/17	1 of 1



# Appendices

## APPENDIX A: WIRING DIAGRAMS (continued)

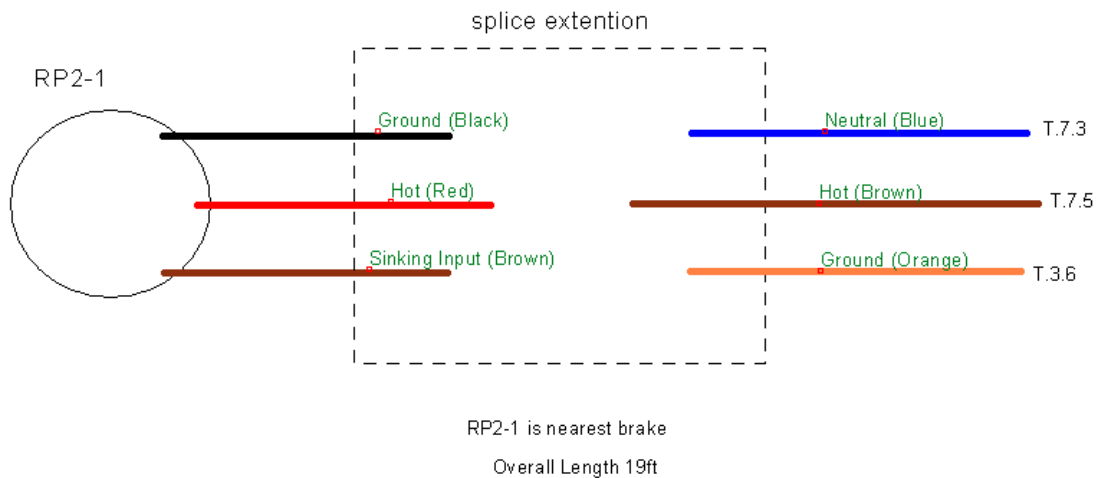

Title RP2-1		
Author AMJ		
File s & Pin-Outs\TEL\Mexico\Current\RP2-1 V.1.dsn		Document
Revision 1.0	Date 2/2/17	Sheets 1 of 1





# Appendices

## APPENDIX A: WIRING DIAGRAMS (continued)

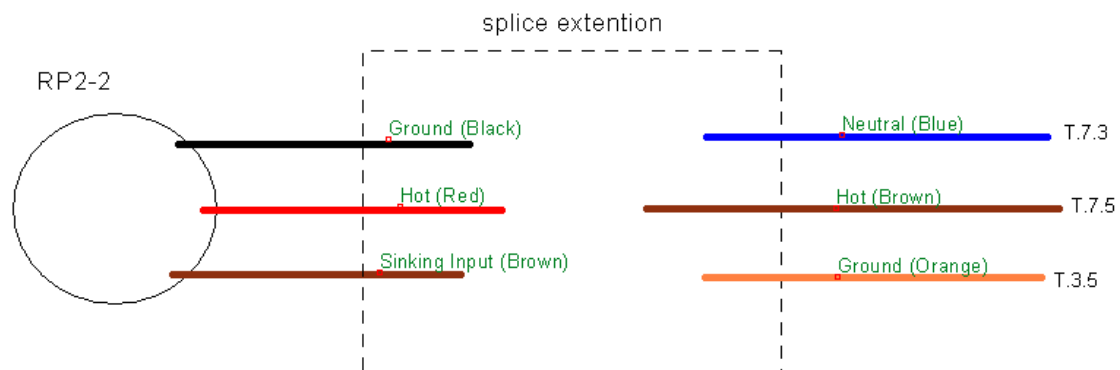

RP2-2 is away from brake

overall length 21ft

Title		
RP2-2		
Author		
AMJ		
File		Document
s & Pin-Outs\TELVMExico\Current\RP2-2 V.1.dsn		
Revision	Date	Sheets
1.0	2/2/17	1 of 1



# Appendices

## APPENDIX A: WIRING DIAGRAMS (continued)

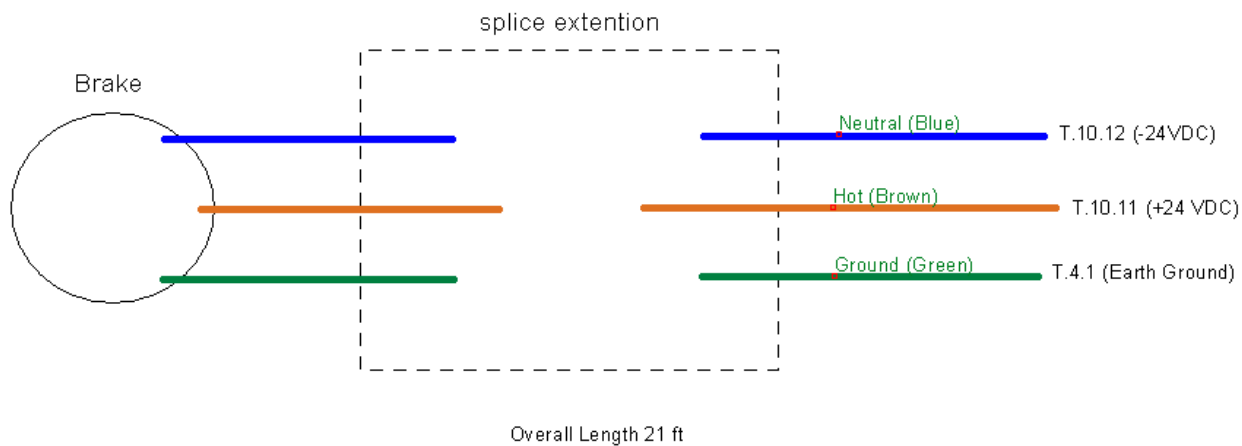

Title Brake		
Author AMJ		
File Pin-Outs\TEL\MExico\Current\Brake. V.1 dsn.dsn		Document
Revision 1.0	Date 2/2/17	Sheets 1 of 1



# Appendices

## APPENDIX A: WIRING DIAGRAMS (continued)

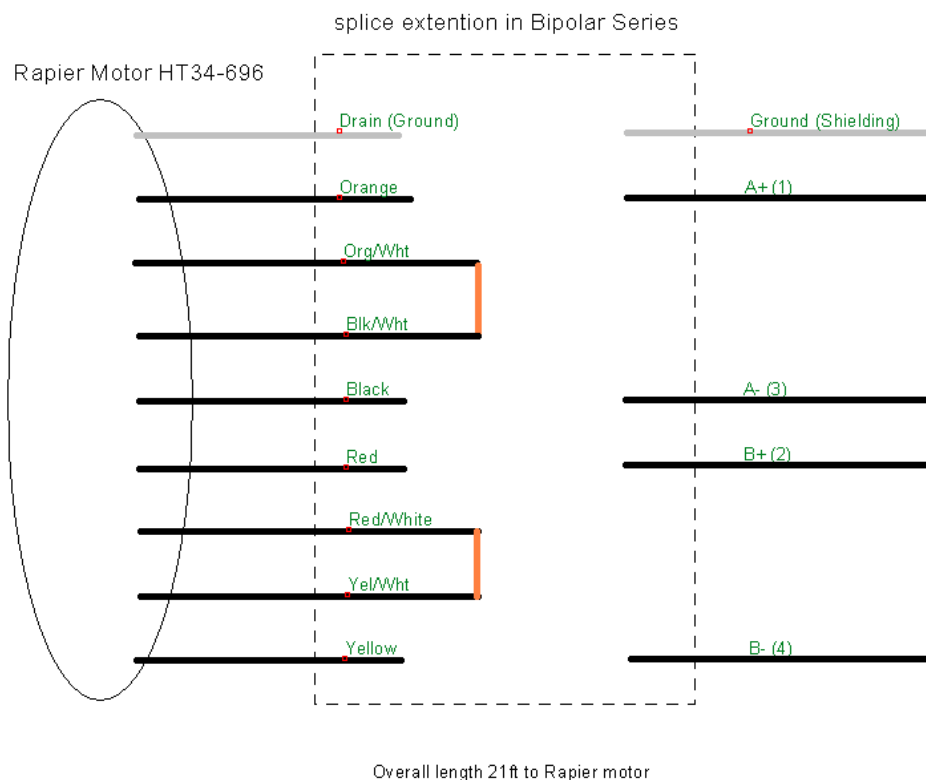

Title		
Rapier Motor HT34-696		
Author		
AMJ		
File		Document
_MExico\Current\Rapier Motor HT34-696 V.1.dsn		
Revision	Date	Sheets
1.0	2/2/17	1 of 1



# Appendices

## APPENDIX A: WIRING DIAGRAMS (continued)

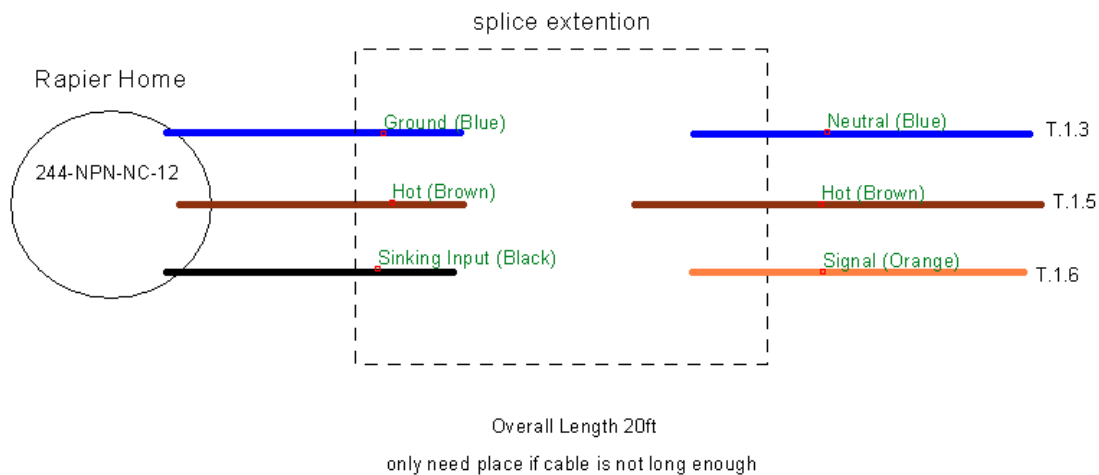

Title		
Rapier Home		
Author		
AMJ		
File		Document
r-Outs\TEL\MExico\Current\Rapier Home V.1.dsn		
Revision	Date	Sheets
1.0	2/2/17	1 of 1



# Appendices

## APPENDIX A: WIRING DIAGRAMS (continued)

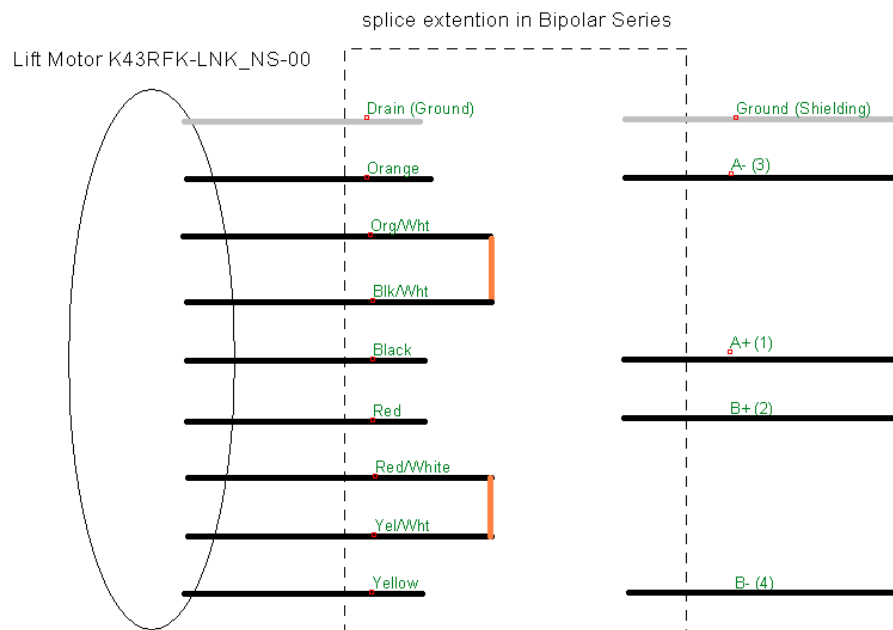

Title Lift Motor K43RFK-LNK_NS-00		
Author AMJ		
File (UNAQ)\Current\Lift Motor K43RFK-LNK-NS-00		Document
Revision 1.0	Date 2/2/17	Sheets 1 of 1



# Appendices

## APPENDIX A: WIRING DIAGRAMS (continued)

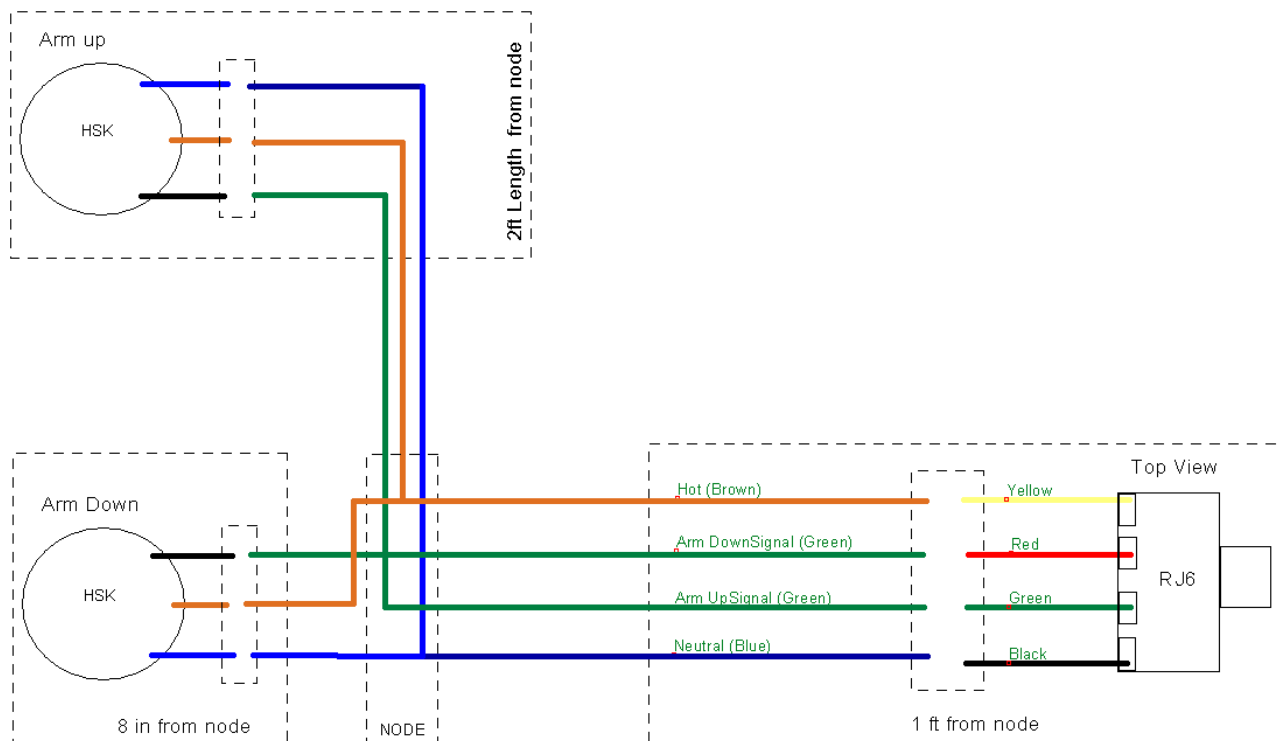

Overall Length 3.5 ft

Title Arm up and Down		
Author AMJ		
File ts\TELMEXico\Current\Arm up and down V.1.dsn	Document	
Revision 1.0	Date 2/2/17	Sheets 1 of 1



# Appendices

## APPENDIX A: WIRING DIAGRAMS (continued)

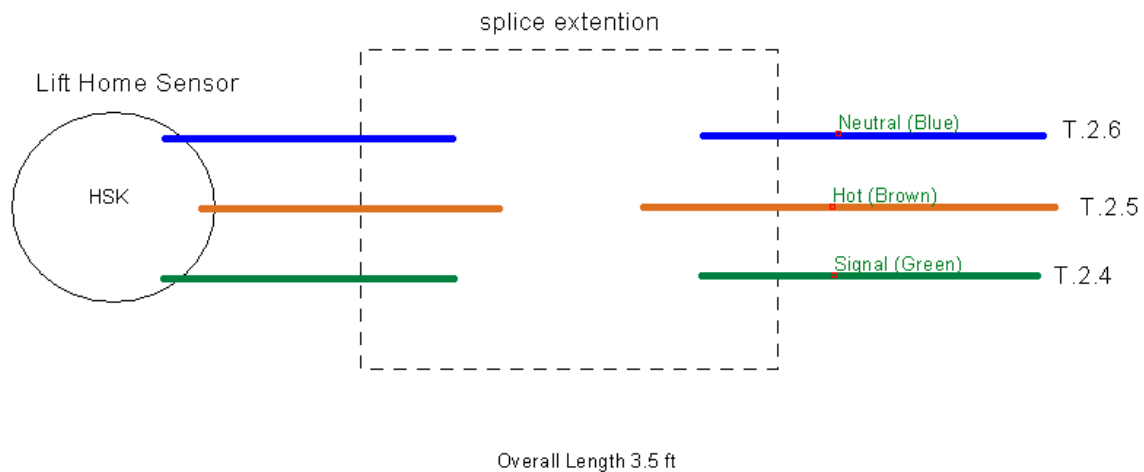

Title		
Lift Home Sensor		
Author		
AMJ		
File		Document
ts\TEL\MExico\Current\Lift Home Sensor V.1.dsn		
Revision	Date	Sheets
1.0	2/2/17	1 of 1



# Appendices

## APPENDIX A: WIRING DIAGRAMS (continued)

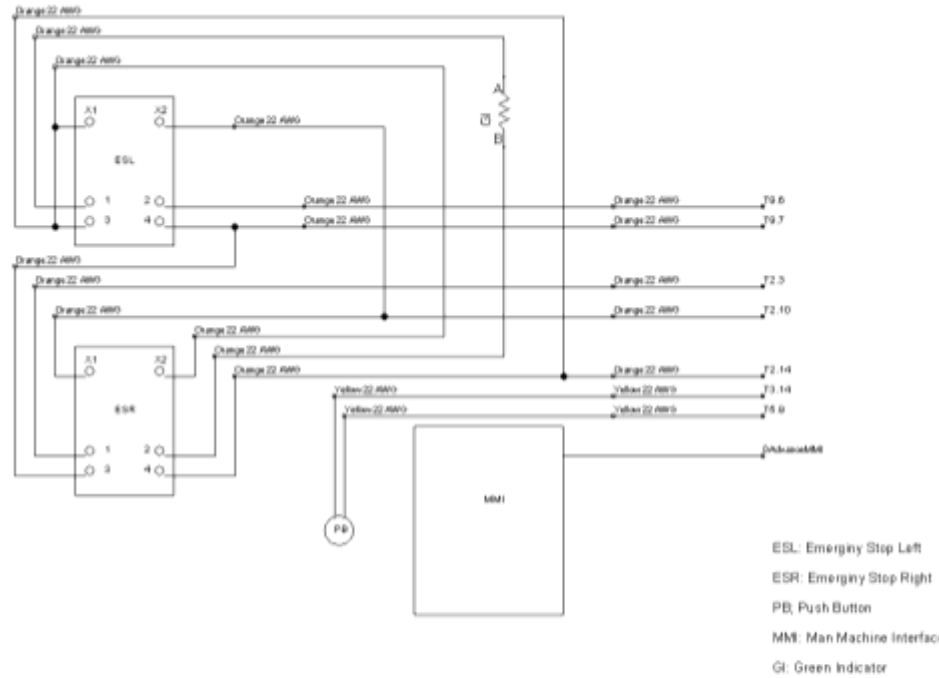

Title <b>Front Pannel</b>		
Author <b>AJ</b>		
File	Document	
splete as of 1.23.2015\Commercy\front safety.dsn		
Revision	Date	Sheets
1.0	1/22/2015	1 of 1





# Appendices

## APPENDIX A: WIRING DIAGRAMS (continued)

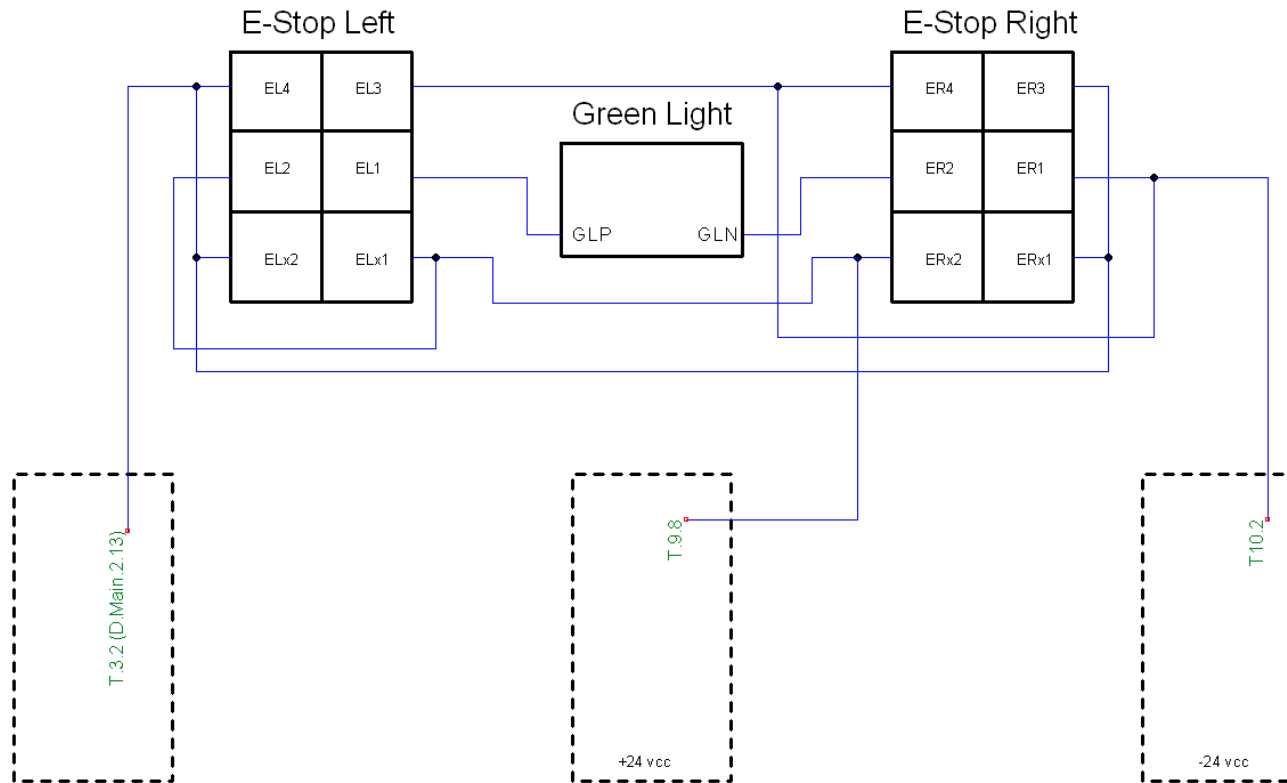

Title E-Stop, Green Light		
Author AMJ		
File ueretaro, MX (UNAQ)\Current\E-stop,Green Light	Document	
Revision 1.0	Date 1/17/17	Sheets 1 of 1



# Appendices

## APPENDIX A: WIRING DIAGRAMS (continued)

Green/Yellow 12 AWG

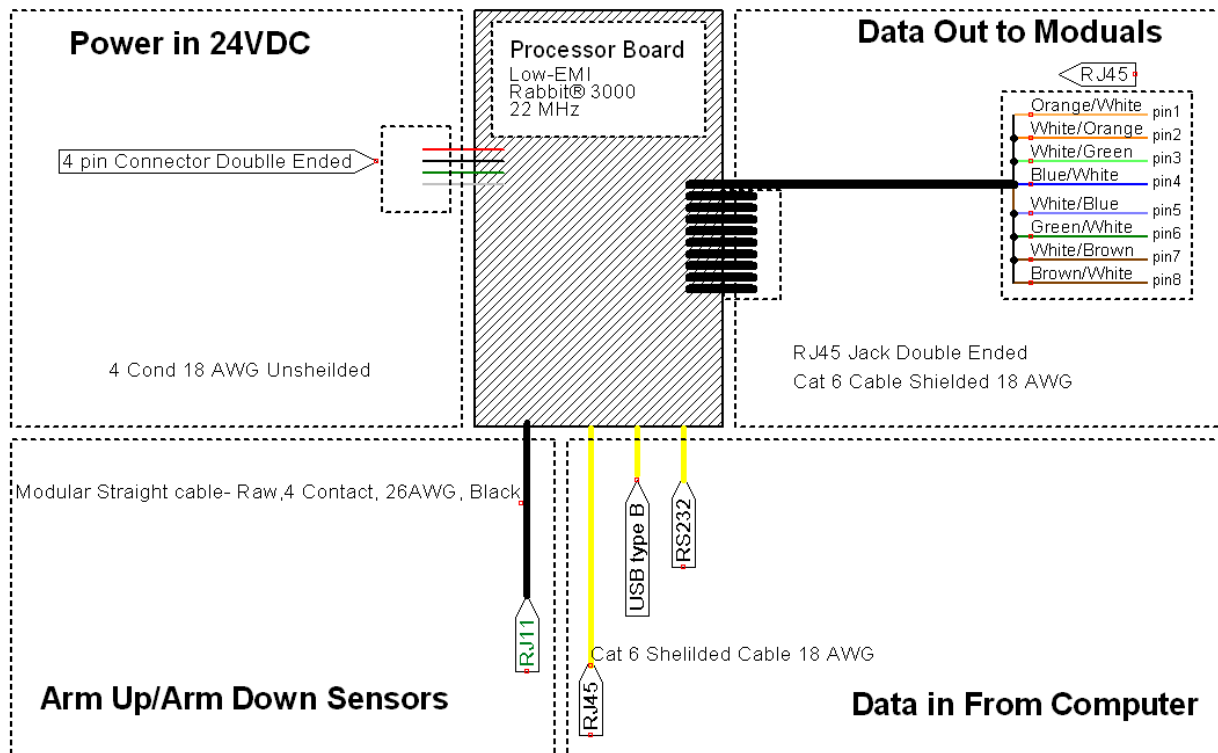

Title Processor		
Author		
File	Document	
ete as of 1.23.2015\Commercy\TEL Overview.dsn		
Revision	Date	Sheets
1.0		6



# Appendices

## APPENDIX A: WIRING DIAGRAMS (continued)

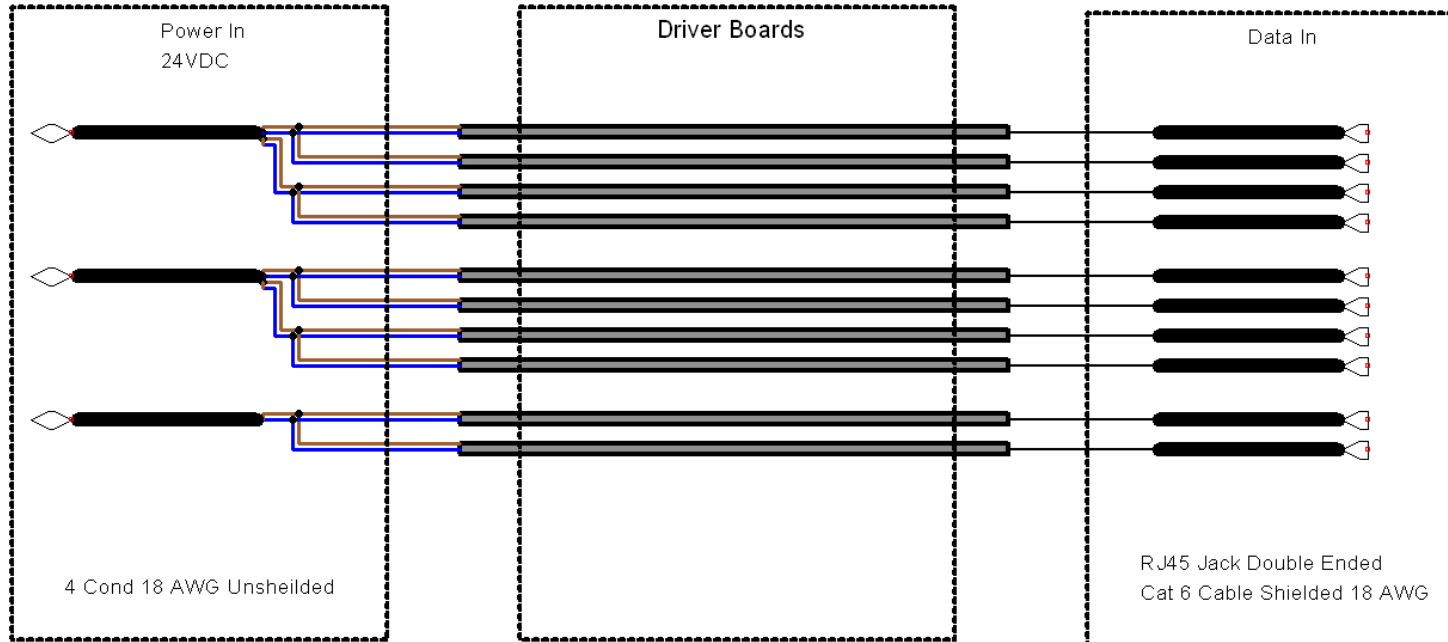

Title Driver Boards		
Author		
File ete as of 1.23.2015\Commercy\TEL Overview.dsn		Document
Revision 1.0	Date	Sheets 2



# Appendices

## APPENDIX A: WIRING DIAGRAMS (continued)

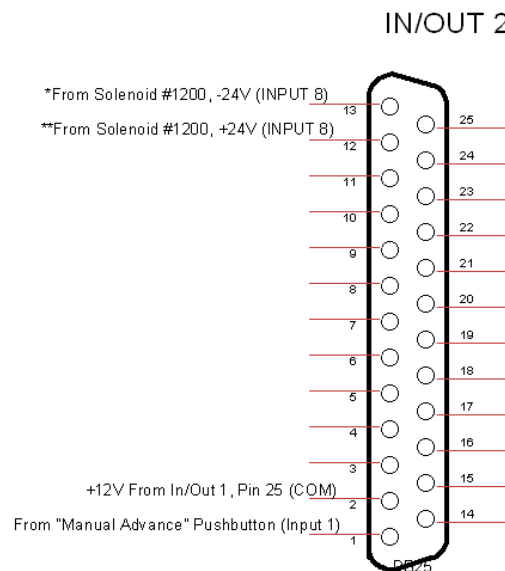
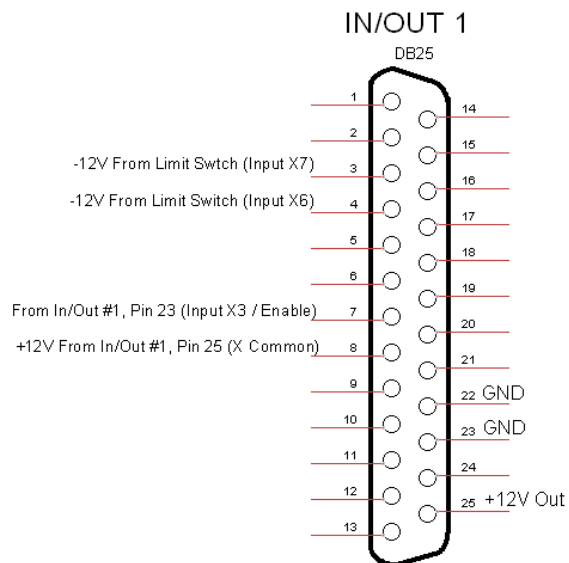

\* -24V On Driver Board Is Closest To The Board (Inner Position).

\*\* +24V On Driver Board Is Farthest Away From The Board (Outer Position).

Title Advance Drive, STAC6-Si-220		
Author KM		
File	Document	
vX (UNAQ)\Current\STAC6-Si, Advance Drive.dsn		
Revision	Date	Sheets
1.0	2/15/2017	1 of 1



# Appendices

## APPENDIX A: WIRING DIAGRAMS (continued)

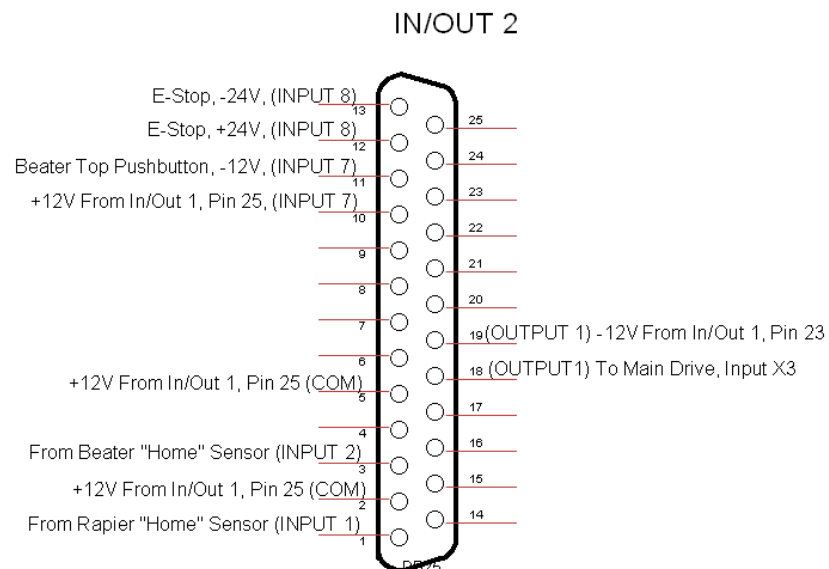
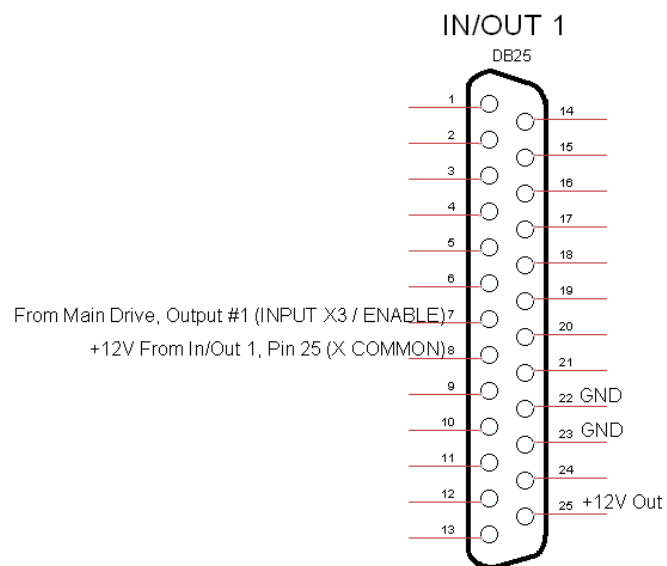

Title <b>Rapier Drive, STAC6-Si-220</b>		
Author <b>KM</b>		
File MX (UNAQ)\Current\STAC6-Si, Rapier Drive.dsn	Document	
Revision 1.0	Date <b>2/15/2017</b>	Sheets 1 of 1



# Appendices

## APPENDIX A: WIRING DIAGRAMS (continued)

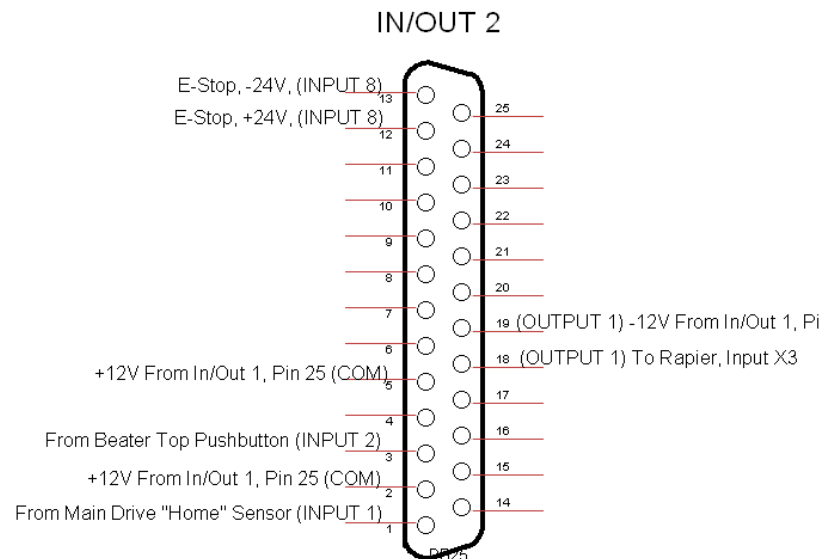
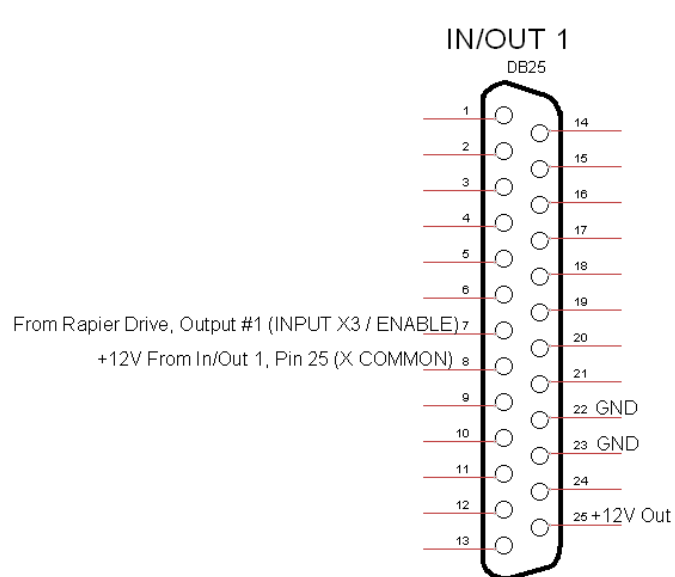

Title		Main Drive, STAC6-Si-220	
Author		KM	
File		Document	
ro, MX (UNAQ)\Current\STAC6-Si, Main Drive.dsn			
Revision	Date	2/15/2017	Sheets
1.0			1 of 1



## Appendices

### APPENDIX B: Jacq3G Lubrication Schedule

This document provides information regarding lubricating the Jacq3G mechanisms. The points described below are intended for yearly lubrication. However, the one year periodicity is subject to the unique conditions that each loom encounters. For example, a loom in constant usage should be lubricated more often, perhaps even once per quarter. The loom owner is responsible for monitoring the need for lubrication and adjusting the schedule as required.

#### Lubricant

You will need two types of lubricant for your Jacq3G loom:

- Clear & Dry Spray Lubricant (we recommend RZ-50 brand)
- Clear Grease (we recommend Tri-Flow brand)

Tri-Flow is found at bicycle shops. RZ-50 is found in hardware stores.





## APPENDIX B: Jacq3G Lubrication Schedule (continued)

### Lubrication Points

*Gel Lubricant:* Note the red arrows and circles in the following pictures for lubrication points.

*Dry Lubricant:* Note the blue circle.

- Drive Chain



- Module pulley bearings – eight per module







## Appendices

### APPENDIX B: Jacq3G Lubrication Schedule (continued)

- Slide bearings and channels – apply lightly in grooves and directly on ball bearings. Q-Tips work great for this work.
- Hooks and knives -- for rust protection (DO NOT SPRAY ONTO CIRCUIT BOARD!)

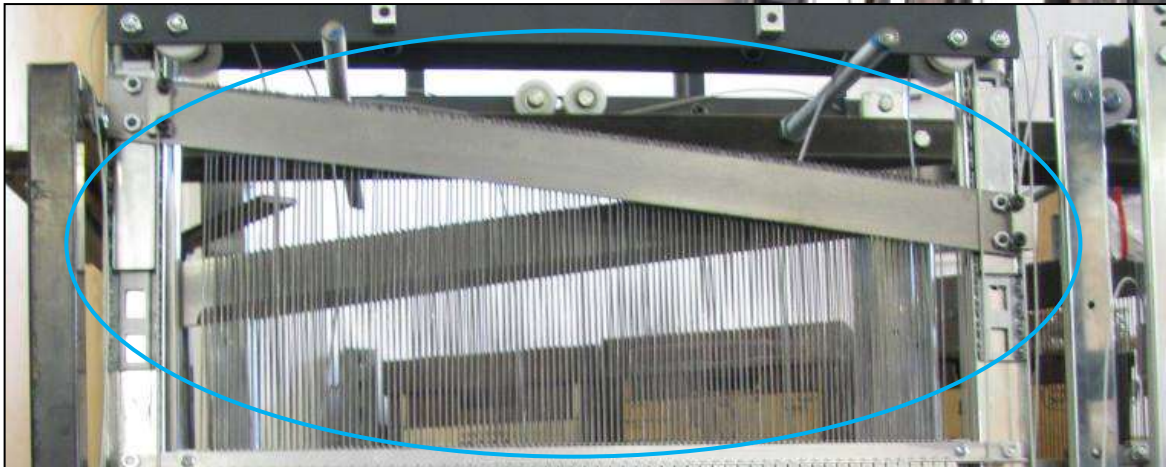



## Appendices

### APPENDIX C: Jacq3G Module Troubleshooting and Adjusting Guide

This document provides information regarding troubleshooting and adjustment of the Jacq3G hook modules. The points covered in this document address a very large percentage of potential issues and adjustments that the user may encounter. However, not all potential concerns are addressed by this guide. Please consult with your AVL technical support representative if you cannot solve your issue from this guide. Additionally,

**CAUTION:** The Jacq3G hook module has both pinch and electrical shock hazards. The pinch hazards include: bearing surfaces, between knives and module frame, and between cables and stationary frame. The electrical shock hazards are anywhere on the printed circuit board, at the solenoid connectors and at the power entry connection. Working around these areas while the loom is powered and mechanisms are moving requires special care. Keep hands and tools away from these areas to avoid injury. Power down the loom or disconnect power to the module to eliminate electrical shock hazard.

There are two primary causes for hook inaccuracy or weaving errors: threading errors and equipment issues. You might be surprised how often people have an issue with their warp – even with very experienced weavers. From our experience, it is by far the most common cause of weaving errors. We think this is partially due to the fact that Jacquard machines, whether it be an AVL or some other brand, are much more ‘warp’ sensitive than harness looms, requiring very high accuracy in warping, threading and slewing. Jacquard looms, do not tolerate twisted threads behind or in front of the hooks, steep side-to-side angles coming off the beam or from the reed, or even large variations in thread tension across the warp. This is the place to begin your troubleshooting. Look for mis-threading, mis-slewing or thread crossover by weaving tabby and observing the opening shed. You want to be extra certain to solve any warp related issues before proceeding with equipment testing and fixes.

#### **Equipment Tests**

We have put together the following tests to diagnose equipment issues. You will need to closely observe the equipment behavior to distinguish causes. Because you may not be accustomed to observing machinery, you may need to perform several iterations of the tests in order to really see what is occurring.



## Appendices

### APPENDIX C: Jacq3G Module Troubleshooting and Adjusting Guide (continued)

**Test #1:** Observe the solenoid plunger without power to the loom. Tap on the plunger. Does it spring out quickly and easily? Does it stick in or move sluggishly? If it does not spring out easily, then you have a misalignment issue. Proceed to **Test 1a**.

**Test #1a:** Check plunger action of the hooks surrounding. If the issue is isolated to a single hook, the individual solenoid may be misaligned. Verify by comparing with the surrounding solenoids. If the issue seems to affect several solenoids, you have a guide alignment issue.

**Test #2:** Observe the solenoid plunger without power to the loom. Tap on the plunger. Does the spring feel stronger or weaker than those around it? If so, you have a bad plunger spring.

**Test #3:** Observe the solenoid plunger in action. Does the solenoid remain activated when treadling a null pick, or never activate when it should? In either case, you have a bad solenoid.

**Test #4:** Observe the misbehaving hook at rest in center-shed position. Does the hook sit significantly closer to the upper knife than the others? If so, you have a bad plunger spring or a bad hook.

**Test #5:** Observe the rear most hooks at rest in center-shed position. Do the hooks clear the upper knife? If not, you have an upper knife alignment issue.

**Test #6:** Observe the misbehaving hook at open shed with all hooks down. Does it want to stay turned more than the other hooks? If you lightly run your finger drawing towards you along the short segment of the hooks, does the misbehaving hook feel stiffer/offer more resistance? If yes, you have a short segment crossover.



## Appendices

### APPENDIX C: Jacq3G Module Troubleshooting and Adjusting Guide (continued)

**Test #7:** Observe the misbehaving hook in action. Is it frequently crossing over/under with a neighboring hook? Does it have abnormal movement side-side or front-back as it slides up and down through the guides? If so, it or possibly the adjacent hook is bad.

**Test #8:** Observe the hook in action and listen carefully. Are the hooks vibrating significantly on this module than on others? Are you hearing squeaking? The hooks and/or slide bearings need lubrication.

**Test #9:** Compare upper and lower knives on all modules at open shed with all hooks down. Are they the same heights and angles? An observable angle difference is a red flag, which must be corrected immediately or it will result in bearing failure. Small variations in knife heights of less than  $\frac{3}{4}$ " are not of concern. Larger knife height variations mean that you have a knife alignment issue.

If you pass these tests but still have a problem, you have a solenoid bar placement issue.

#### **Equipment Fixes**

**Solenoid bar placement:** Incrementally adjust/test the solenoid mount bar until issue goes away. Incremental adjustment is typically  $\frac{1}{2}$ -1 turn of the nut; test with tabby with alternately activates the upper and lower solenoid bars. Adjustment can be made independently at front and back hardware, however it is a good idea to loosen both front and back before making the adjustment to avoid binding/bowing of the solenoid bar. Pick the side that is closest to the bad hook. If the bad hook is relatively centered, adjust both sets of hardware. Adjust the solenoid mount bar away from the knife if the hook is lifting when it should not; in when the hook does not lift.

**Bad solenoid:** Replace the bad solenoid. Note that when pulling the electrical wires from the black plastic connector; gently pry out the tab in the connector with a pin to release the solenoid wire. CAUTION: Make sure you do not accidentally drop the plunger spring onto the printed circuit boards while it is powered or you risk shorting the printed circuit board.



## Appendices

### APPENDIX C: Jacq3G Module Troubleshooting and Adjusting Guide (continued)

*Bad hook:* Replace the bad hook. CAUTION: Make sure you do not accidentally drop the plunger spring onto the printed circuit boards while it is powered or you risk shorting the printed circuit board.

*Bad plunger spring:* Replace the bad plunger spring. CAUTION: Make sure you do not accidentally drop the plunger spring onto the printed circuit boards while it is powered or you risk shorting the printed circuit board.

*Solenoid alignment:* See if you can identify which direction the solenoid is cocked. Loosen solenoid screws, carefully turn the solenoid into the proper alignment then retighten the screws.

*Middle guide alignment:* In the center shed position, loosen the three middle guide screws. Adjust the middle guide until the short and long hook segments are perfectly in alignment. Check this alignment at front, back and middle of the module, then retighten the screws.

*Upper guide alignment:* If the hooks show any forward or rearward lean, adjust hex nuts for the upper guide until the hooks are vertical. Loosen the outer hex nuts, then cycle hooks up & down with null picks. Looking down from above while at open shed and hooks down (null pick), observe the hook alignments in relation to each other and the upper guide. If the hooks appear paired, the solenoid mount bars are misaligned from front to back. Determine which solenoid mount bar is incorrect by observing hook leaning forwards or backwards, loosen its hex nuts, slide the solenoid mount bar until the hooks are no longer paired, then retighten the solenoid mount bar hardware. Loosen the outer hex nuts for the upper guide. Recycle the hooks up & down with null picks. Align the upper guide with slightly more gap between the hooks and guide towards the back of the loom. Retighten hardware.

*Short segment crossover:* If you examine a bare hook, you see that it has a longer and shorter segment both terminating in short u-bends, with the two segments joined by a u-bend. The short segment can become trapped behind the long segment or adjacent hook long segments. When this occurs, the hook will have a strong tendency to turn. Observation and fixing at a tight sett can be difficult, so opening the sett may be required. To fix, simply move the short segment from behind to its proper position.



## Appendices

### APPENDIX C: Jacq3G Module Troubleshooting and Adjusting Guide (continued)

*Lubrication:* See Jacq3G Lubrication Schedule document.

*Knife alignment:*

- 1) Knife angle: If the angle of a knife is observably different from the neighboring modules it must be remedied before any further loom use. Failure to do so will cause bearing failure. The knife angle and knife height alignment procedures are the same -- see below.
- 2) Knife height: ***Knife alignment procedure requires that the heddle springs be released from the anchors at the bottom of the loom and that the loom be at center shed. Once complete, reconnect the springs and reset the shedding programming to double shed.***
  - a) Upper knife angle adjustment: Loosen the button head cap screws for the drive cable clamps mounted to the knife. The upper knife should slide smoothly without damaging the cable sheathing. Slide the knife until the front and rear inner bearing carriers are in contact with the hardware at the bottom of it bearing travel. If the outer bearing carrier touches the hardware first, apply additional force to overcome the inner to outer carrier force until the inner bearing carrier is in the correct position. Retighten the button head cap screws.
  - b) Lower knife angle adjustment: Loosen the button head cap screws for the drive cable clamps mounted to the knife. The lower knife should slide smoothly without damaging the cable sheathing. Slide the lower knife until the front and rear inner bearing carriers are  $\frac{3}{4}$ " from the hardware at the top of it bearing travel. If the outer bearing carrier is hitting the hardware and preventing the inner carrier from reaching the measurement, apply additional force to overcome the inner to outer carrier force until the inner bearing carrier is in the correct position ( $\frac{3}{4}$ " from the hardware at the top of it bearing travel). Retighten the button head cap screws.