

# **Studio Dobby Loom User's Manual**



**AVL Looms  
2360 Park Avenue  
Chico, CA 95928-6785  
U.S.A.**

**530 893-4915  
530 893-1372 fax  
sales@avlusa.com  
www.avlusa.com**

**Version 1  
6/1/2018  
Original Instructions**



---

---

Introductory Information .....	1
Safety .....	2
Introduction.....	4
Loom Features .....	5
Receiving Your New Loom .....	8
Unpacking An Assembled Loom.....	9
Assembly Instructions.....	11
Before You Begin .....	12
Inserting Nuts And Bolts .....	13
Assembling Side Frames.....	14
Left And Right Side Frame Assembly.....	17
Install The Dobby Cam Cylinder.....	18
Installing The Cross Members .....	20
Install The Cloth Storage Beam.....	22
Install The Lower Front Assembly .....	23
Install The Brake Pedal.....	26
Install The Treadle Pulley Support Assembly .....	28
Install The Spring Lever Supports .....	30
Squaring The Completed Frame .....	32
Install Harness Pulley Support Assembly.....	33
Install The Beater Assembly.....	34
Install The Dobby Head .....	40
Harness Assemblies .....	42
Install The Warp Beam .....	48
Connect the Treadle Cables .....	55
Install The Shelf .....	59
The Compu-Dobby .....	60
Weaving Instructions .....	61
Warping The Plain Beam.....	62
Warping The Sectional Beam .....	70
Combining Sectional And Plain Warping.....	84
Threading, Sleying, & Tying On .....	85
Additional Loom Information.....	91

---

---

Loom Maintenance .....	92
Troubleshooting .....	95
The Fine Print .....	99
AVL Customer Service.....	100
AVL Warranties.....	100
Notice to Users in the European Union .....	101

# **INTRODUCTORY INFORMATION**

## SAFETY

### Before Getting Started:

Please read the entire manual before using the loom.

### Warnings:

#### WARNING:

EQUIPMENT SHOULD ONLY BE USED FOR TEXTILE MANUFACTURING. IF THE EQUIPMENT IS USED IN A MANNER NOT SPECIFIED BY THE MANUFACTURER, THE PROTECTION PROVIDED BY THE EQUIPMENT MAY BE IMPAIRED.



#### WARNING:

ELECTRICAL SHOCK HAZARD. DO NOT TAMPER WITH ELECTRICAL WIRES OR OPERATE THE LOOM WITH SAFETY PANELS OPENED OR REMOVED.



#### WARNING:

PINCH, CRUSH, AND FINGER CUT-OFF HAZARDS. DO NOT OPERATE THE LOOM WITH SAFETY PANELS OPENED OR REMOVED. DO NOT PLACE HANDS IN MOVING MECHANISMS OR SCISSORS.



**WARNING:**  
EQUIPMENT PANELS ARE AWKWARD AND HEAVY. TO AVOID MUSCLE STRAIN OR INJURY, USE PROPER LIFTING TECHNIQUES AND A HELPER.

**WARNING:**  
DO NOT POSITION EQUIPMENT IN A WAY TO BLOCK OR IMPEDE ACCESS TO DISCONNECTING DEVICES, EMERGENCY STOPS, OR ON/OFF BREAKER SWITCHES

**WARNING:**  
USE OF CONDUCTIVE FIBER OR YARN ON OR AROUND THIS EQUIPMENT WILL VOID WARRANTY AND MAY DAMAGE EQUIPMENT.

**WARNING:**  
THIS EQUIPMENT IS CLASSIFIED FOR LIGHT INDUSTRIAL ENVIRONMENT ONLY. OPERATION OF HIGH-CURRENT DRAW EQUIPMENT (EX. MIG WELDER) ON THE SAME ELECTRICAL CIRCUITS MAY CAUSE EQUIPMENT FAILURE.

### **Safety Features:**

Covers and shielding separate weaver from moving components where pinch hazards exist. Do not reach under a covers and shielding while the loom is operating.

## INTRODUCTION

### About AVL

AVL Looms has been in the business of designing and building some of the world's finest handweaving looms since 1977.

Jim Ahrens had been building and designing looms for a number of years before Jon Violette, the "V" in AVL, approached Ahrens about a partnership in 1977. Violette, an industrial management professional, had discovered Ahrens' work through his sister who ran the Pacific Basin School of Textiles in Berkeley, where Ahrens was a volunteer advisor.

The two men worked together in the Bay Area for three years until Violette moved Ahrens and Violette Looms to Chico, where it officially became known as AVL Looms Inc., and has operated ever since.

In 1982, Violette was instrumental in the development of the first computerized dobby, then called the "Apple Dobby". He retired from active life in the company in 1987.

Once known for our production looms, AVL has broadened its line considerably and we now offer customers a full spectrum of fine weaving equipment, ranging from our small Home Looms, to our Industrial Dobby Looms, Rug Looms, and Jacquards.

### SDL Design Concept

In 1996 we began, in earnest, to design a loom that would meet the very specific needs of university weaving programs and small design studios. According to our research, such a loom would need to be small, extremely robust, and very basic in its mechanical systems. However, it would still need to offer harnesses in sufficient number to handle complex weaving structures and had to be computer capable.

The result of that process is the loom you have before you. It is in all respects an *Ahrens* loom, however, it benefits significantly from suggestions made by noted weaver and teacher, Ann Sutton, from other weaving instructors, and from the work of our own very capable design staff.

The Studio Dobby Loom is not a production loom. It was designed from the ground up as an *instructional* loom that might serve equally well as a *sampling* loom. Such mechanisms as Automatic Cloth Advance and Auto Warp Tensioning, extremely valuable in a production environment, have



been replaced by systems more appropriate in an instructional or design context, where speed is less an issue, but ease of maintenance is more. We think you'll be delighted with the functionality afforded by this design.

## **LOOM FEATURES**

The Studio Dobby Loom is available in either a 20" or 30" width and can come with 16 or 24 harnesses. No matter which width or number of harnesses you choose, the following features are available. The assembly of the loom in each case is also the same.

### **Brake System**

Studio Dobby Looms are equipped with a locking brake system. This means that the warp beam will be held absolutely captive — will not release warp — until you depress the Brake Pedal. It's fairly fool proof and affords very taut warps. When your fell has moved as far forward as you're comfortable, and you wish to advance your warp, depress the pedal and crank the warp forward with the Cloth Advance Handle. You will have one Brake Pedal per warp beam and you'll need to depress them simultaneously if you wish to advance from two beams.

### **Tension Device**

The tension device is an optional feature that allows you to advance the warp without depressing the brake pedal. You will find that you can weave with less warp tension with a weight control than with the conventional ratchet system. Once the correct tension adjustment is made, it will be maintained automatically as the weaving is advanced. For light, fragile warps, it may be necessary to use a lighter weight than the one that comes with the loom and for dense, heavy warps, you may have to add some weight to the arm. You can order half size weights from AVL Looms. This can be used by itself for very light tension or can be used with the existing weight if more tension is needed.

### **Cloth Storage System**

The Cloth Storage System consists of the Cloth Storage Beam (immediately in front of your knees), the Cloth Storage Apron, and the Cloth Advance Handle and pawl.

## Removable Breast and Separation Beams

You will have either two or three of these beams. They are interchangeable and, besides enhancing the structural integrity of the loom and giving you a convenient arm rest, serve to establish the warp in its horizontal plain. The beam at the front of the loom is called a Breast Beam; the beam at the rear, a Separation Beam. If you have two warp beams you'll need two Separation Beams. Illustrations in the Assembly Instructions identify the mounting position of the second Separation Beam, if you have one. These beams can be moved to the interior slot to help with threading.

## Beater

The SDL comes standard with a sliding beater. This beater moves forwards and back on four precision bearings. To remove the reed, simply unthread the two nuts at the Upper Reed Support, pull off the support, and pull out the reed.

Some weavers are more comfortable with a Swinging Beater. Except for its mode of travel, it is the same as our Sliding Beater. You may adjust (rack) it by loosening the four bolts that attach it to its arms, bringing it fully forward and retightening. The Swinging Beater will not take a good adjustment unless a reed is in place.

## Warp Beams

If you have purchased a Sectional Beam, you will find it to be extremely adaptable to your needs. Because each of its hoops is removable, you may create sections of any width calculated in one-inch increments.

An AVL Sectional Beam with metal hoops has holes for the hoops at 1" sections. The wheel comes with enough metal hoops to setup 2" sections. More hoops can be ordered from AVL if narrower sections are desired. For wider sections, remove as many metal hoops as needed.

There are two things to remember:

- 1) You may only use a Sectional Beam in the upper position.
- 2) You cannot use two warp beams when using a Sectional Beam.

The Plain Beam comes with an apron which will allow you to maximize the length of your warp. You may use two Plain Beams at a time, however, if you do so, you must orient them so that the handle on the *upper* beam is to the *left* side of the loom and the handle on the lower is to the right.

The loom is designed to carry two Plain Warp Beams or a Single Sectional Beam.

## Dobby Head and Compu-Dobby

The Dobby Head is the box with many cables that is installed on the right side of your loom. It works in tandem with the Compu-Dobby and together they provide the interface between your computer and loom. The operation of the Compu-Dobby is explained in its own manual. It is extremely important that you achieve and maintain a good adjustment of the Solenoid Box. If this device is out of tune, your harnesses will behave erratically.

## Treadles

The Right Treadle is used to raise the harnesses. With your Compu-Dobby on, you simply push down on the Right Treadle and the selected harnesses rise. Relax and the harnesses fall.

You might expect that, if the Right Treadle *raises* harnesses, the Left must help *lower* them. It doesn't — gravity and the Spring Levers bring the harnesses back down. The real function of the Left Treadle is to return the Dobby Arm to its proper reset position after each lift. If this is not done, harnesses will either drop or fail to lift altogether at the following lift.

You must **fully** depress the Left Treadle at each pick. It only performs its necessary function at the very end of its throw and will offer relatively little resistance.

## Cam Cylinder

The Right Treadle Cable is connected directly into the Cam Cylinder. When you treadle, the pulley which the cable is connected into gathers and pulls cable around itself. As it does so it conveys mechanical advantage to the Right Treadle, making it easier for you to lift.

## Harnesses

Your SDL will have either polyester or metal heddles. The supporting harnesses (or shafts) are different for the two heddle types: metal heddles, whether twisted wire or flat steel, are suspended from rigid frames; polyester heddles are carried on transverse Harness Sticks, top and bottom. In all cases the harnesses are stabilized at the bottom by a series of spring-tensioned levers.

Some weavers like metal heddles because they believe they are easier to thread; others prefer the lighter and quieter polyester heddles.

## **Spring Levers**

These hold the harnesses down and prevent your heddles from floating. The important thing to remember is that the system is designed so that it can be "fine tuned" for each particular warp, so experiment with it. In general, for most medium tensioned warps, you will find that adjusting will not be necessary. There is a spring lever at each end of the harness, with a chain and a spring between each set.

## **RECEIVING YOUR NEW LOOM**

If your loom was assembled by AVL it will have arrived in a single large box. Looms delivered outside the continental U.S. will probably be further contained within a protective frame-work. Accessories too large to include with the loom will be located in supplementary boxes. Looms delivered knocked down will arrive in several large and small boxes.

Please confirm that you received the number of boxes indicated on your copy of the Bill of Lading. If not, you should call the delivery company, as they should still have boxes to deliver to you.

## **Shipping Damage**

Looms are rarely damaged in shipping, however, if you do discover damage please call the delivery company immediately. Then call us at 530 893-4915.

Freight haulers are not agents of AVL and only the consignee, the customer, *you*, may file a damage claim. It's best if you save your packing materials; some freight companies wish to examine them as part of their claims process.

AVL will immediately replace the damaged parts and invoice you for them. You, in turn, should present the bill to the freight company. They, in turn, will pay it (they always have!). It's inconvenient for all of us, but really not too troublesome and we'll make an extra effort to get your replacements to you quickly.

## Assembled or Not

If you purchased your loom pre-assembled, please proceed now to the instructions provided in the next section: *Un- packing an Assembled Loom*. If you requested your loom knocked-down, move on to *Assembly*.

However, we do urge you to read the introductory material before you proceed.

## UNPACKING AN ASSEMBLED LOOM

Again, if we assembled your loom at our facility, it will arrive wholly or mostly in one box.

- 1) Cut and remove the plastic strapping.
- 2) Use a screwdriver or other flat implement (not a knife, please!) to separate the top and bottom trays from the cardboard sides.
- 3) Pull off the cardboard top cap.
- 4) Lift the sides up and over the loom (they are joined into a single piece).
- 5) Remove the tape and any ancillary boxes. We try always to leave a tab at the end of each piece of tape, so you can pull it off rather than cut it.
- 6) Get a helper to aid you in lifting the loom off its ply-wood skids.
- 7) Move the loom to its permanent location.
- 8) Carefully untape the beater, harnesses, and all other mechanisms.
- 9) Replace any cables that have obviously been dislodged.
- 10) Carefully check the loom for damage.

Once you've installed the Compu-Dobby your loom will be weaving ready. Before installing the it, first make a quick inspection. You may wish to consult the Parts List in the appendix if any of our part names are unfamiliar to you.

- 1) Remove the Shelf Retention Pin at the rear of the Harness Pulley Supports. Slide the shelf out and set it aside.

- 2) Working down from the top of the loom, please verify that:
  - a. All Harness Cables are located in their pulleys.
  - b. All Harnesses are attached to Harness Cables.
  - c. Dobby Cables are not tangled in the Dobby Head.
  - d. Harness Springs are connected between Spring Levers.
  - e. Treadle Cables are strung over pulleys.
  - f. Treadles operate freely.
  - g. Sliding Beater (if equipped) operates smoothly.
  - h. Swinging Beater (if equipped) swings smoothly, without interference from adjacent parts.
  - i. Cloth Advance Handle engages with Cloth Storage Beam Ratchet and advances beam.
  - j. Depressed Brake Pedal(s) releases tension on cables.
- 3) Replace the shelf.

# **ASSEMBLY INSTRUCTIONS**

## BEFORE YOU BEGIN

Putting together your new loom may look intimidating at first, but this manual is designed to guide you through the process with clear steps, pictures, and diagrams. If the manual is unclear or confusing at any point, call us at 530-893-4915. We're here to help.

There is a definite advantage in assembling your own loom. You'll come to know it very well, sooner than you otherwise would, and the better you know your loom, the better you'll be able to use and maintain it.

Tools:

- Hammer
- Socket Wrench with 1/2", 7/16", and 9/16" sockets.
- Large Bladed Screwdriver
- Medium Phillips Screwdriver
- Large Phillips Screwdriver
- Scissors
- Crescent Wrench
- Occasional Extra Pair of Hands

Packed with your hardware are a few additional tools that you may not have. They'll be there when you need them.

Once you've gathered your tools, open all the boxes and lay the contents out just as you find them. Please DO NOT remove the tape from any of the components until we tell you. Please, too, leave the hardware bags unopened until they are required.

For protection in shipping, packing materials of several sorts are used around the pieces of your loom. Check the packing materials carefully for loom parts. You may want to keep all the shipping materials until the loom has been put together to make sure nothing is lost.

The boxes your loom comes in are custom made for shipping your loom. If you have space to store them, you may want to keep them for future shipping or moving. Please keep the box and packing materials for the Compu-Dobby if at all possible in case you ever need to ship it to us for repair.

Remove all strapping tape and bubble pack. Layout all of the parts so that you will be able to identify each one as they are identified in the instructions.



You'll need a space about 5' x 5' to assemble your loom. In addition, a conveniently located desk or table will come in very handy for several of the operations.

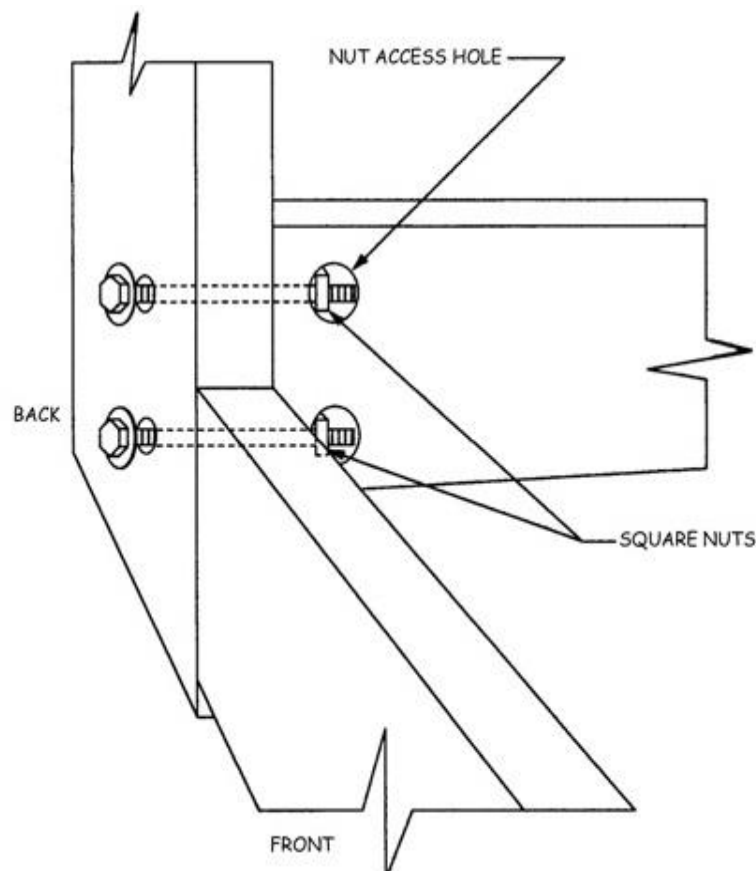
Depending on your particular style of work, the entire assembly operation will take between three and eight hours.

## INSERTING NUTS AND BOLTS

### NOTE:

Given the limited space provided by the nut access holes, it can be challenging at first getting the nuts onto the bolt ends. You'll find it helpful to push each bolt in just until it just appears in the access hole. Move the nut into position over the end of the bolt and hold it with your finger. Slowly turn the bolt clockwise and when the nut engages, tighten it most of the way down.

If your fingers are too big to comfortably manipulate the nut, try holding it with a flat blade screwdriver or needle-nose pliers.



**Figure 1 - Inserting Nuts**

**Note:**

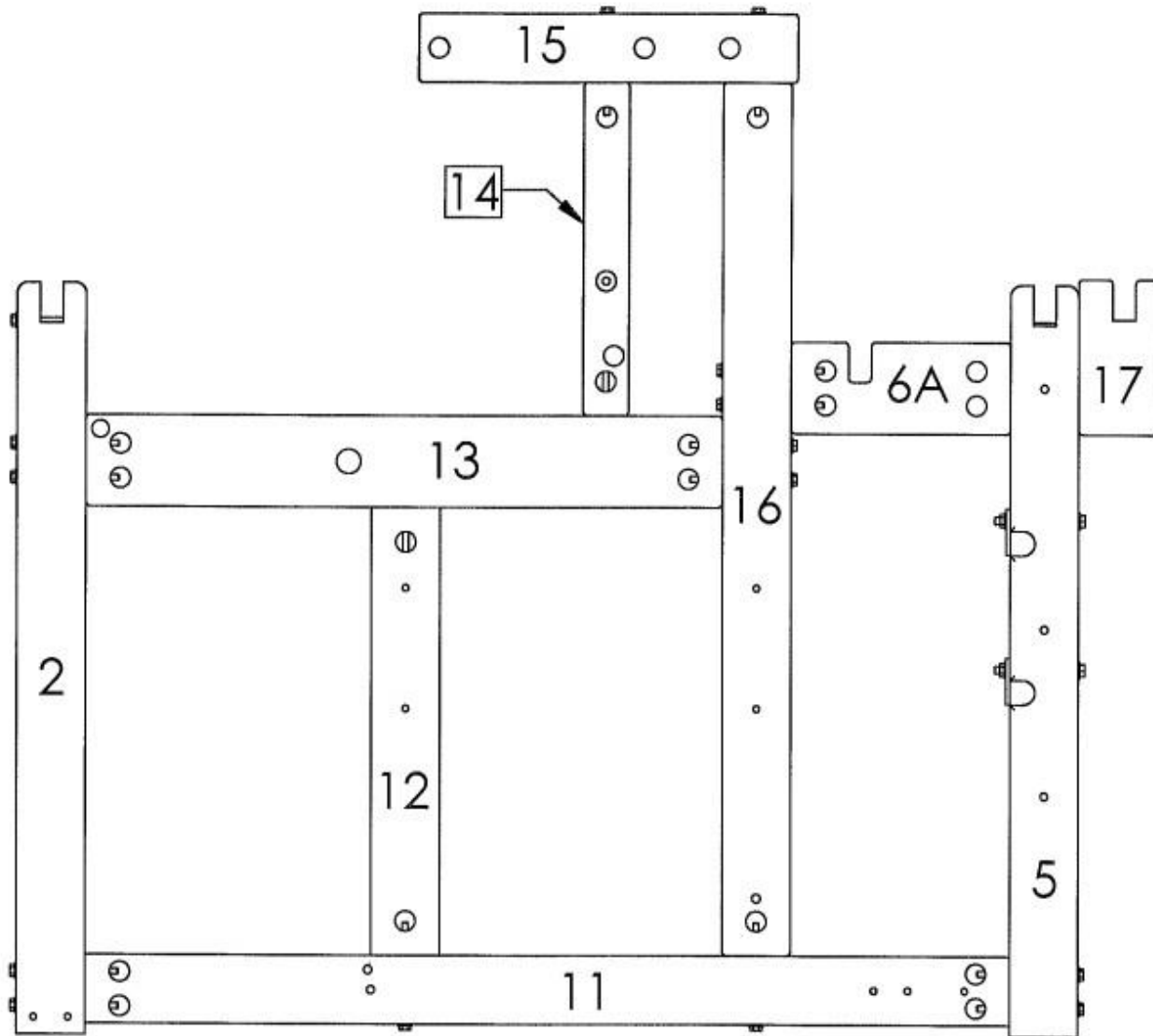
As you are building the loom, do not tighten the nuts all the way down. You will tighten everything down once you have squared and leveled the loom as described in [Squaring The Completed Frame](#) on page 32.

## ASSEMBLING SIDE FRAMES

The next two pages show the left and right sides of your loom with numbers that are cross-referenced to the directions in this manual. You may want to remove the following pages and use them as reference while you are building your loom. Note that some of the hardware referenced in the instructions has already been installed in the frame.

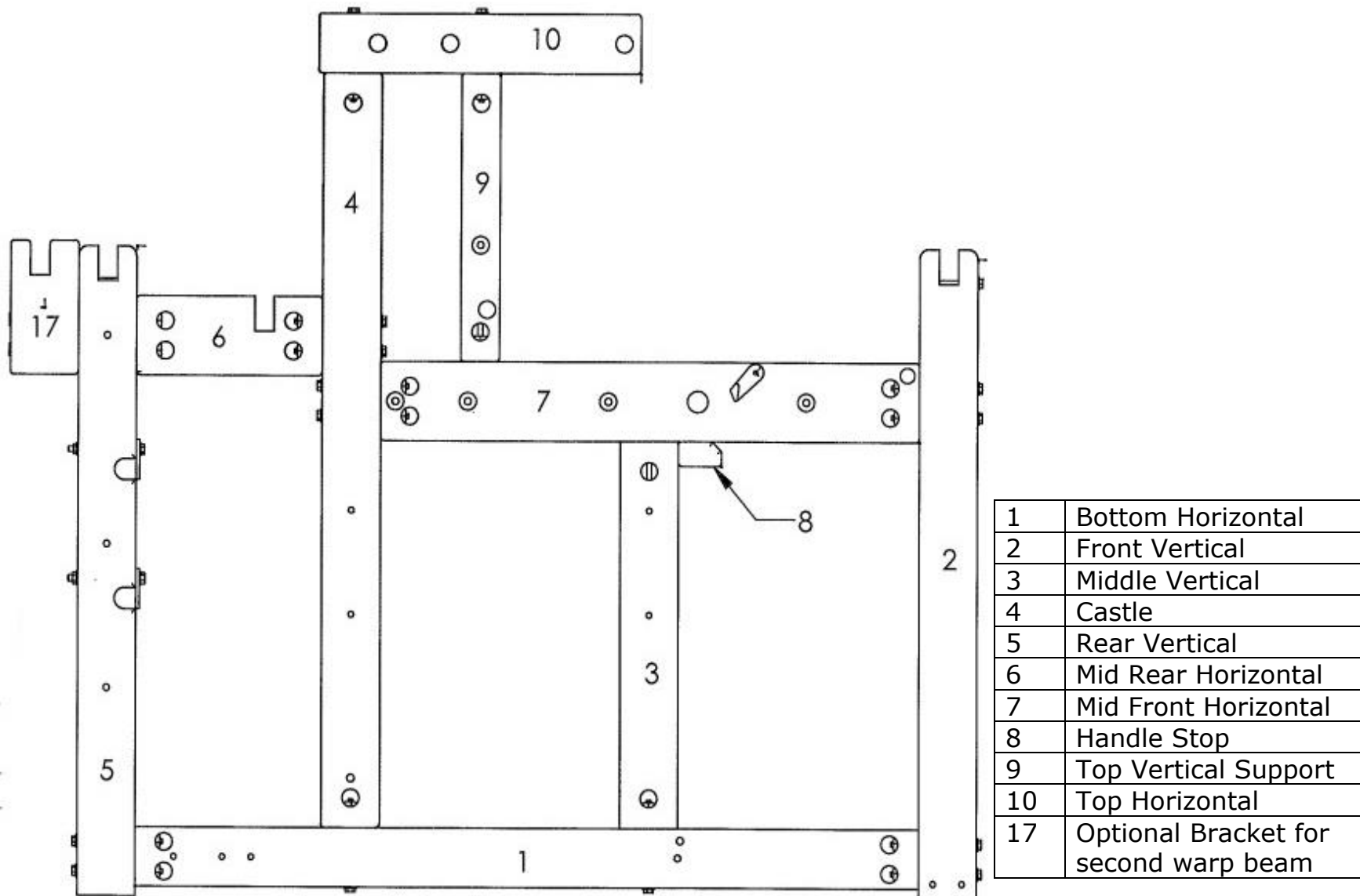
**Note:**

Because our looms are customizable, there may be small differences between the pictures and diagrams in this manual and the actual loom you received. As always, if anything seems confusing, please call us at 1-800-626-9615 or contact us through our website: [www.avlusa.com](http://www.avlusa.com).



2	Front Vertical
5	Rear Vertical
6A	Mid Rear Horizontal
11	Bottom Horizontal
12	Mid Vertical
13	Mid Front Horizontal
14	Top Vertical Support
15	Top Horizontal
16	Castle
17	Optional Bracket for second warp beam

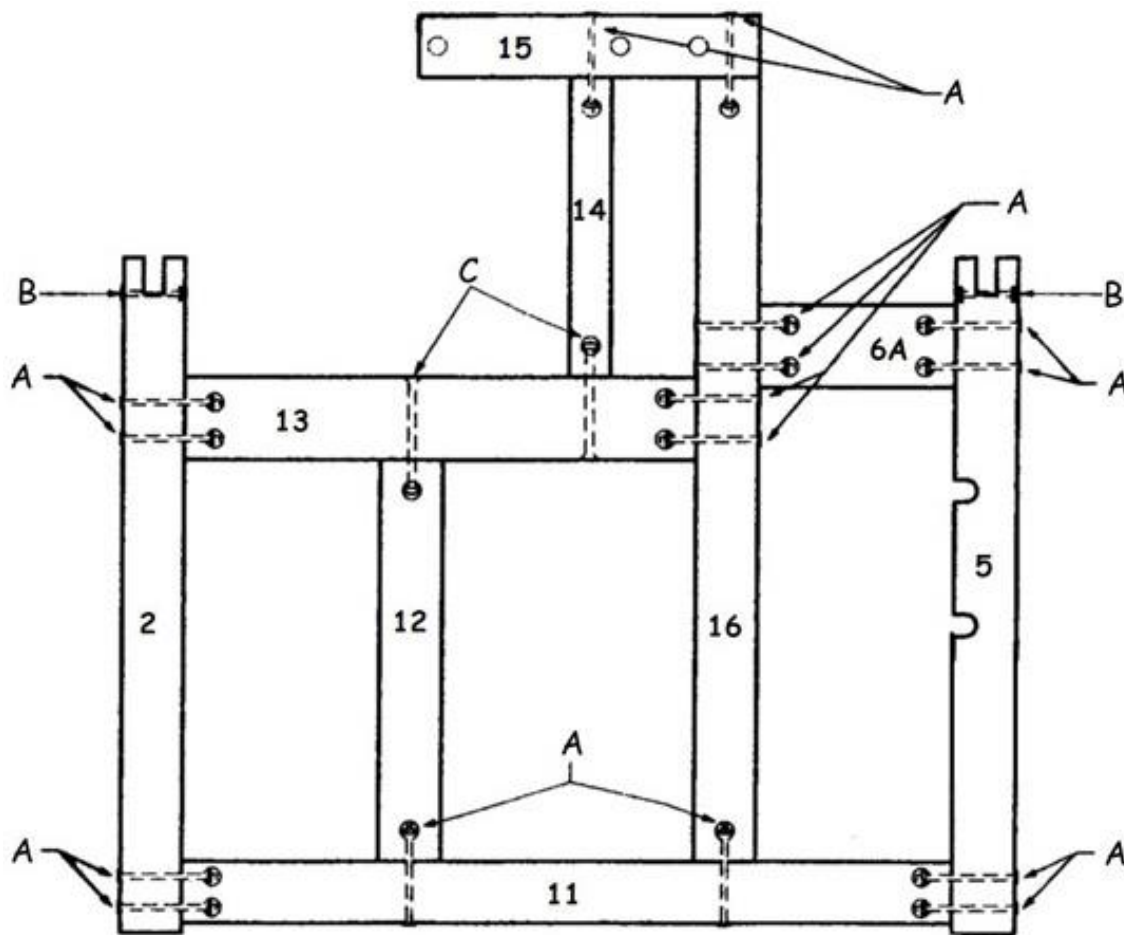
**Figure 2 - Left Side of Loom**



**Figure 3 - Right Side of Loom**

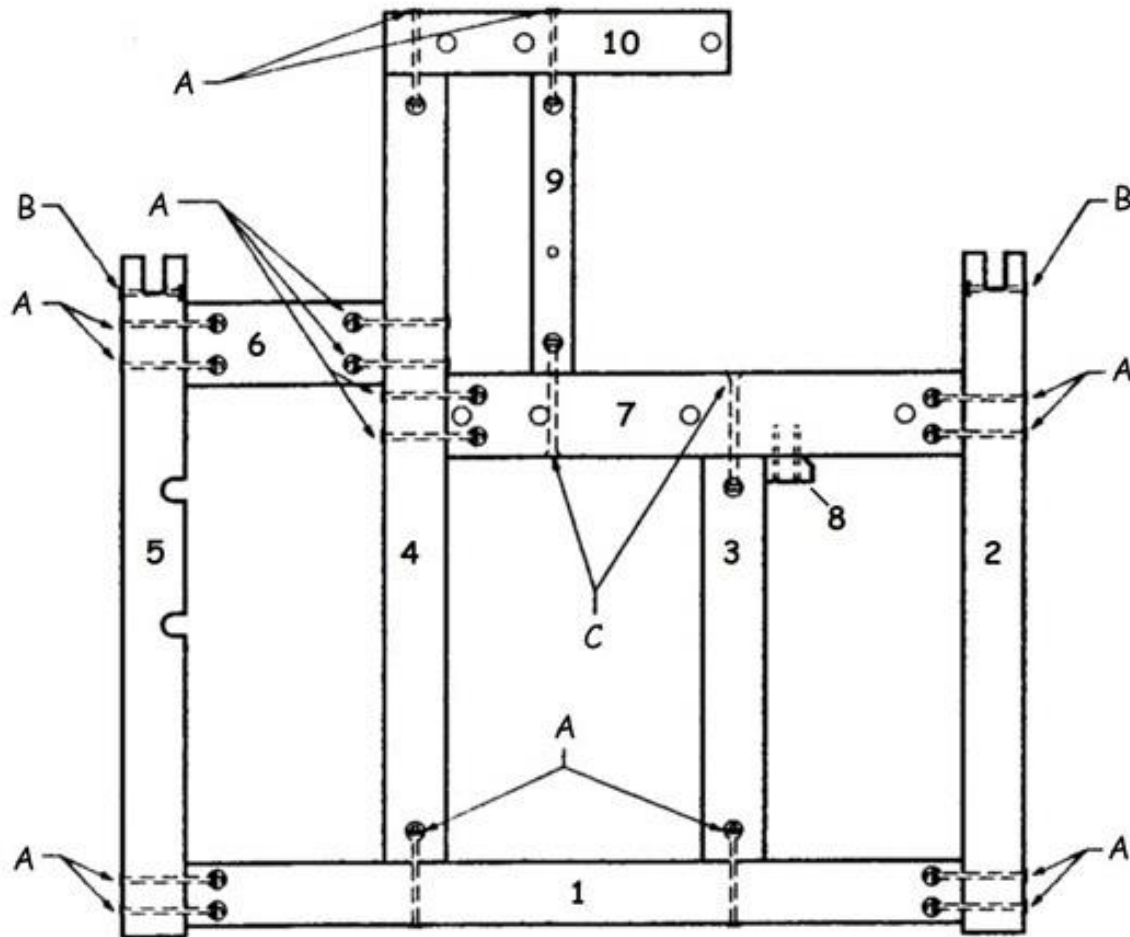
## LEFT AND RIGHT SIDE FRAME ASSEMBLY

- 1) Locate the Hardware Packets and parts that came with the Frame. Sort the hardware to make sure that all parts are present and accessible during assembly.
- 2) Put the pieces together as shown in the diagrams for the left and right side.
- 3) Insert the bolts into the holes as shown and attach the nut as described earlier.



**Figure 4 - Left Side of Loom**

Code	Bolt type
A	1/4" x 4 1/2" HB ASSY
B	1/4" x 3" HB ASSY
C	1/4" x 5 1/2" HB ASSY



**Figure 5 - Right Side of Loom**

## INSTALL THE DOBBY CAM CYLINDER

The Dobby Cam Cylinder provides mechanical advantage to the right treadle, greatly reducing the amount of effort required for harness lifting.

This assembly is supported by an axle that spans parts #3 and #4.

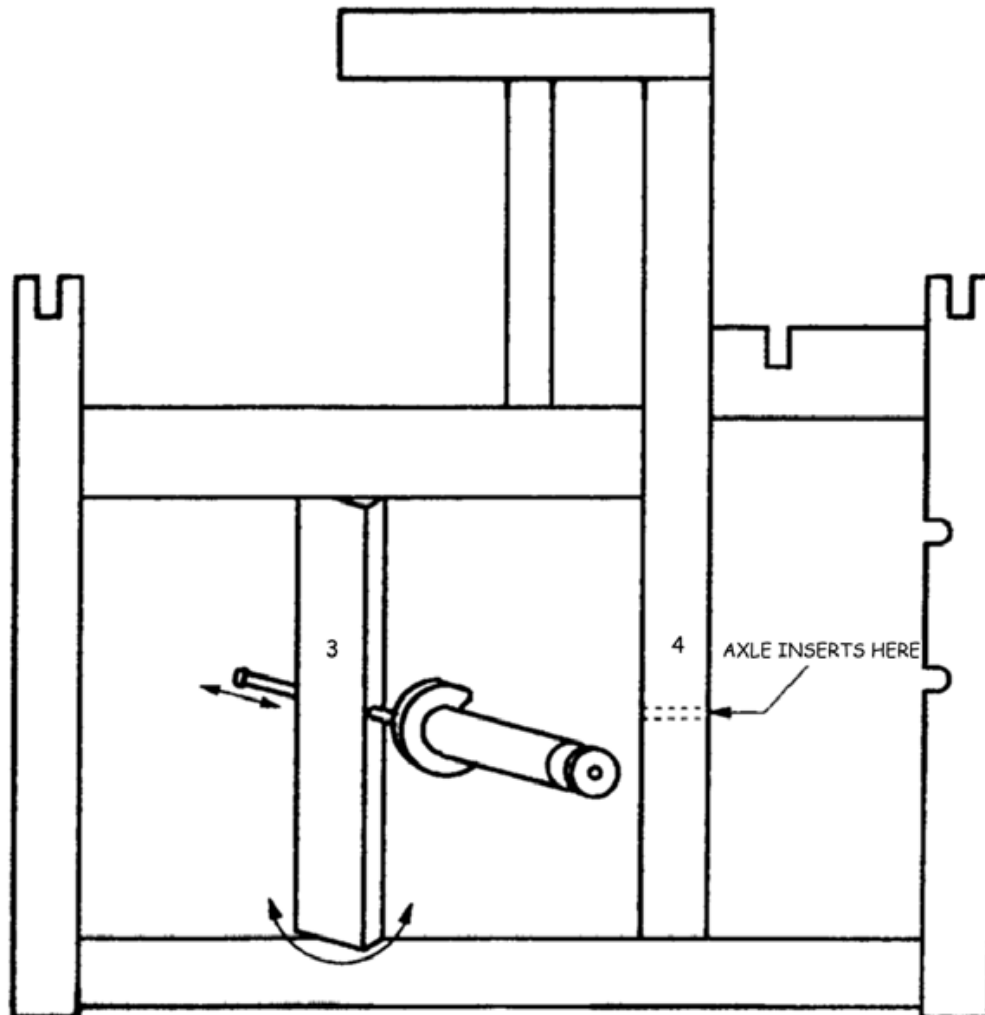
- 1) Locate the assembly and withdraw the axle. It should slide out effortlessly.

### NOTE:

If the axle does not slide out smoothly, make sure there isn't anything (string, tape) lodging the axle in the cam.

- 2) You will need to loosen the bolts holding part #3 on the right side frame. Rotate part #3 about 20 degrees.

- 3) Insert the axle from the left side, into the mounting hole in part #3. Push it about half way through the hole.



**Figure 6 - Dobby Cam Cylinder Installation**

- 4) Thread the Cam Cylinder and wooden pulley back onto the axle.
- 5) Pivot #3 back into position so that the free end of the axle now points to the opposite mounting hole in #4.

- 6) Push the axle through the hole in #4 until the end comes out the other side.



**Figure 7 - Cam Cylinder**

- 7) Find the stop collars provided in the hardware bag. Position one on each end of the axle against the frame.
- 8) Use the Allen wrench provided with the hardware to tighten the stop collars.
- 9) Tighten the bolts that secure #3.

## INSTALLING THE CROSS MEMBERS

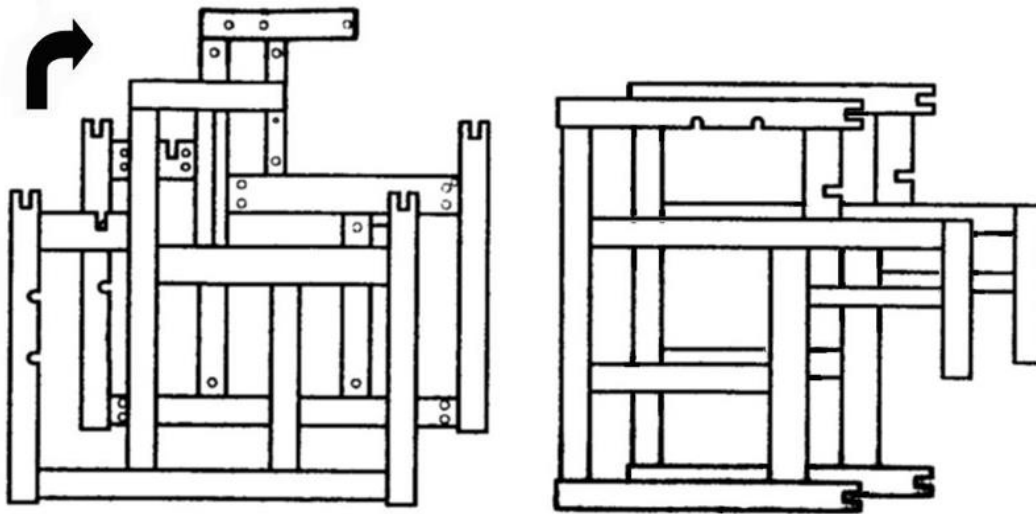
In the next stage of your loom assembly, you'll attach the various members that connect the left and right side frames. We've already sub-assembled many of the components and you'll progress quickly through these operations. When done, your loom will look like a loom.

The tools you already have at hand will suffice.

- 1) Please locate Lower Back (#17) and the Cross Member Hardware Pack.
- 2) Sort the hardware.
- 3) Select four 3-1/4" Chrome Plated bolts, with square nuts. Remove the nuts.
- 4) Stand both side frames on their feet, about 2' apart, with their access holes facing inward. Put yourself at the front of the frames.

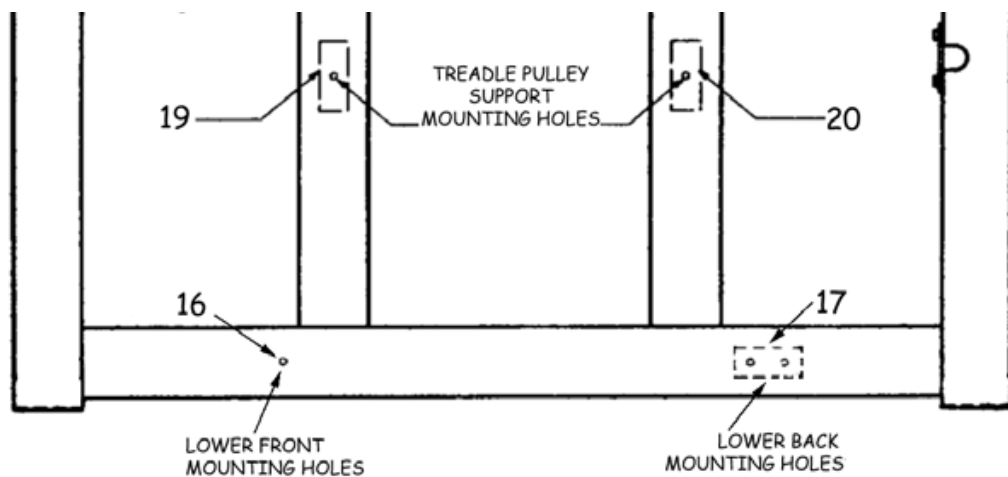


- 5) Pivot each frame forward 90 degrees so that they lay on their Front Verticals (#2).



**Figure 8 - Placing the loom on its front**

- 6) Locate the mounting holes for the Lower Back in the accompanying diagram.



**Figure 9 - Cross Member Mounting Hole Locations**

- 7) Position the four mounting bolts in their holes on each side frame.
- 8) Bring the Lower Back into position and orient it so that the access holes are facing the floor when the loom is upright.
- 9) Push the bolts into the access holes at both ends of the Lower Back; add the nuts and tighten down well.
- 10) The frame is now self-supporting. Put it back on its feet.

## INSTALL THE CLOTH STORAGE BEAM

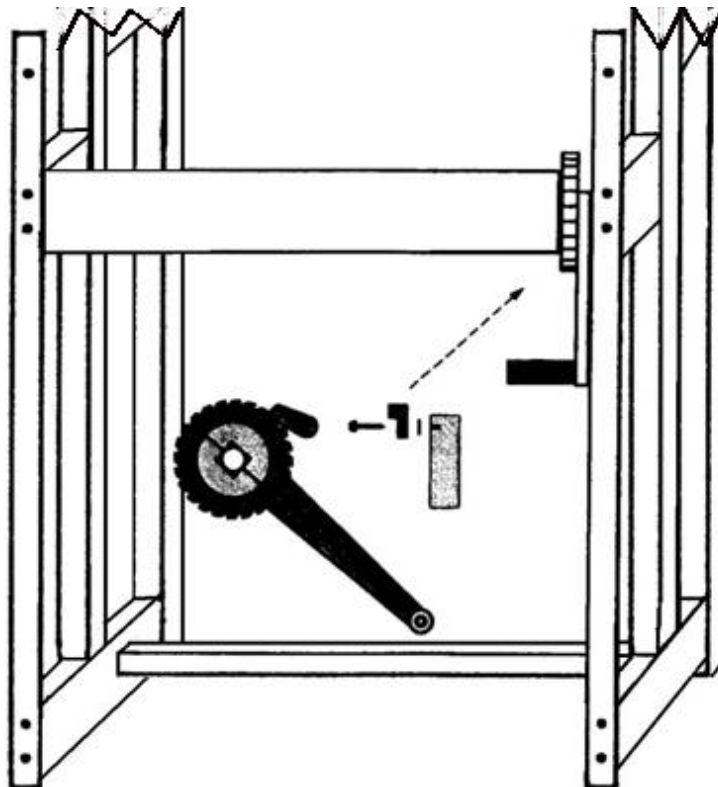
The Cloth Storage beam **MUST** be installed at this point in the assembly process. Its axle fits into holes in the side frames and once the frames are joined further, it will be impossible to add the beam.

Locate the beam mounting holes in each side frame. These are about 1" in diameter and lay opposite one another in the Mid Front Horizontals. They are drilled completely through the frames.

The Cloth Storage Beam has a metal ratchet on one end. Find the beam now. Find, too, the Cloth Advance Handle and bring beam and handle to the loom.

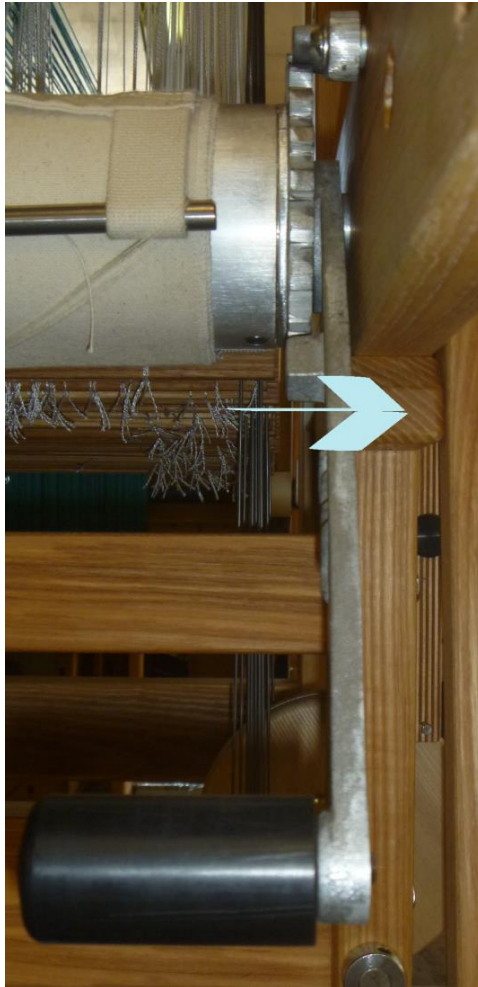
You'll see that the advance handle has an oblong hole at one end. Fit this hole over the cloth storage beam axle (ratchet side). Be sure that the wooden handle will point to the interior of the loom.

- 1) Find the mounting holes on each side frame and slip both ends of the beam the holes.



**Figure 10 - Cloth Storage Beam and Handle**

- 2) Allow the handle to rest atop the small block installed in the right side frame.



**Figure 11 - Handle Rest**

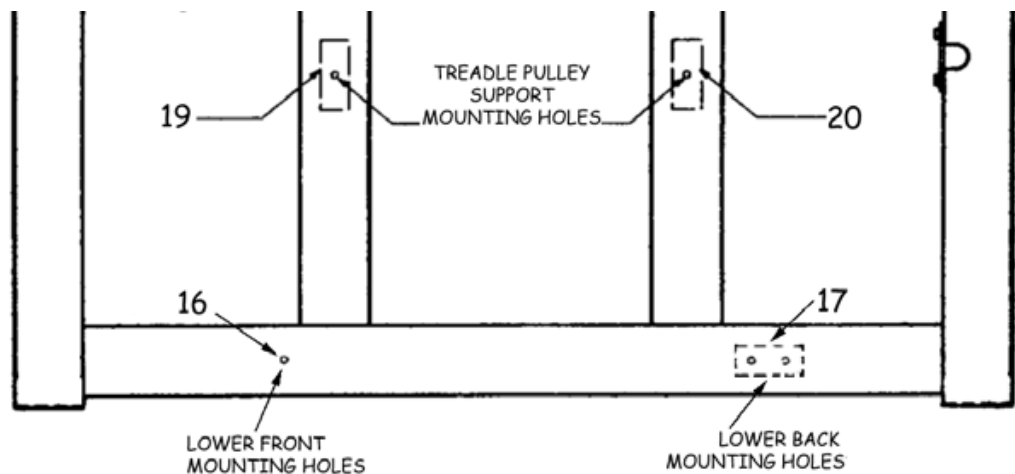
- 3) Push the side frames together. Take care not to dislodge the beam until the lower front is installed.

## **INSTALL THE LOWER FRONT ASSEMBLY**

You will place the loom on its back in order to install the treadles on the loom.

- 1) Move to the front of the loom and pivot it away from you and lay it on its Rear Verticals.

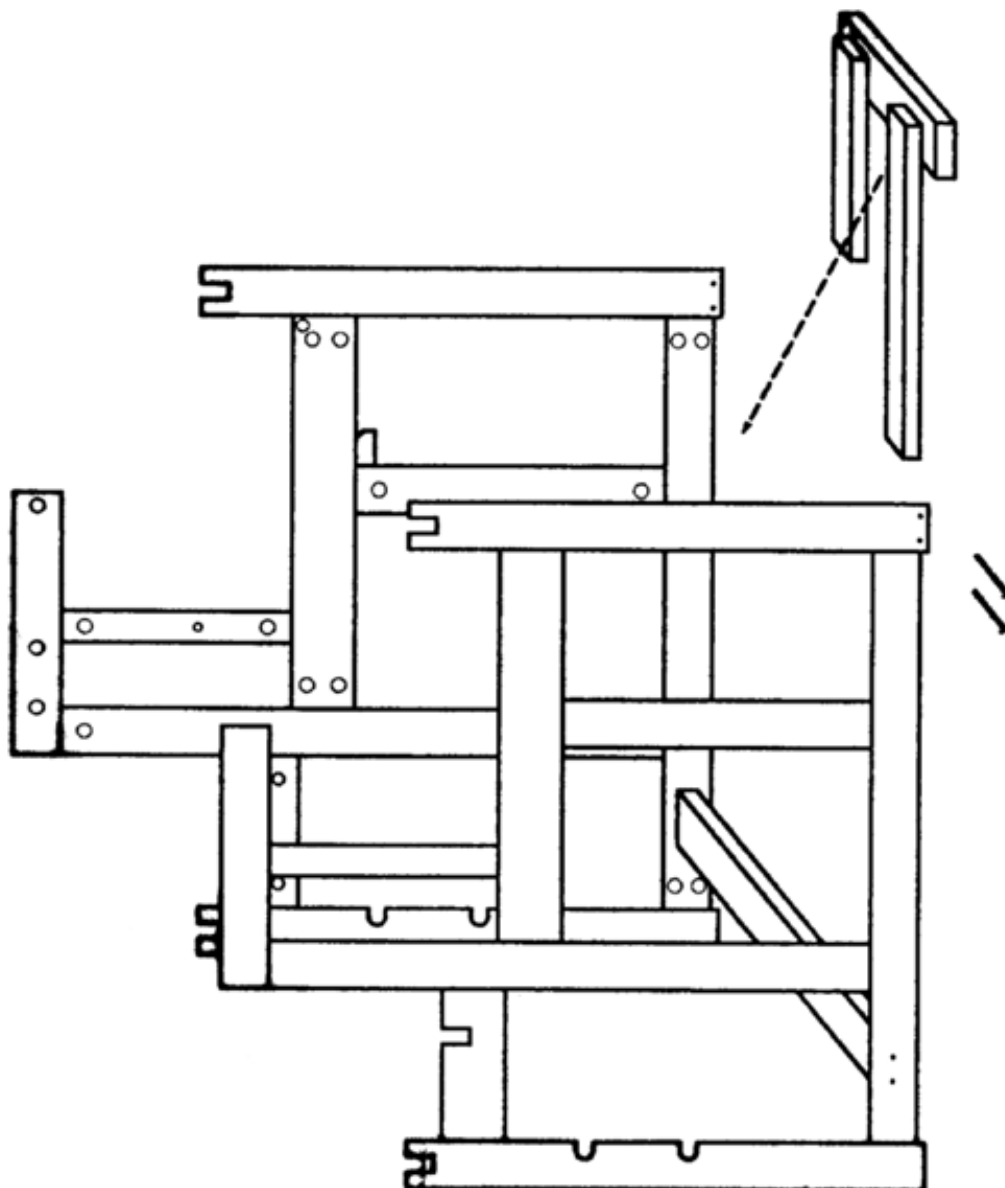
- 2) The Lower Front Assembly consists of a cross member, treadle assembly, and treadle mounting hardware (#16, #35, #36). Find it and bring it to the loom.
- 3) From the treadle rod, remove the two mounting blocks.
- 4) Leave the two stop collars in place on the rod. Slide the long treadle on from the left and the short treadle on from the right. Slide the mounting blocks onto the ends of the rod. Now screw the mounting blocks to the cross member.
- 5) Select and remove the nuts from another four attachment bolts. Identify the Lower Front mounting holes on the diagram.



**Figure 12 - Cross Member Mounting Hole Locations**

- 6) Place the mounting bolts in the bottom holes in the Front Verticals.
- 7) Bring the Lower Front Assembly into position. Orient it so that the longest treadle is on the left.

- 8) Install the assembly and just allow the treadles to hang.



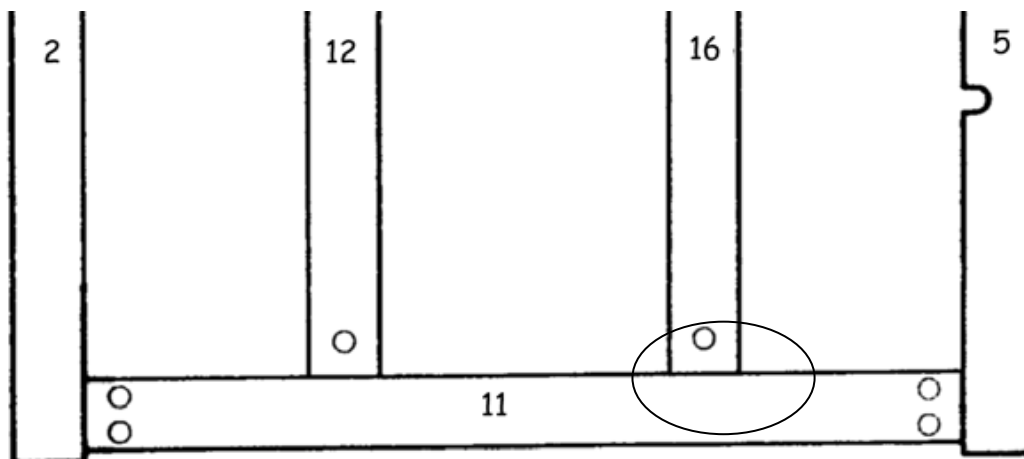
**Figure 13 - Place treadles on loom**

- 9) Place the loom back on its feet.

---

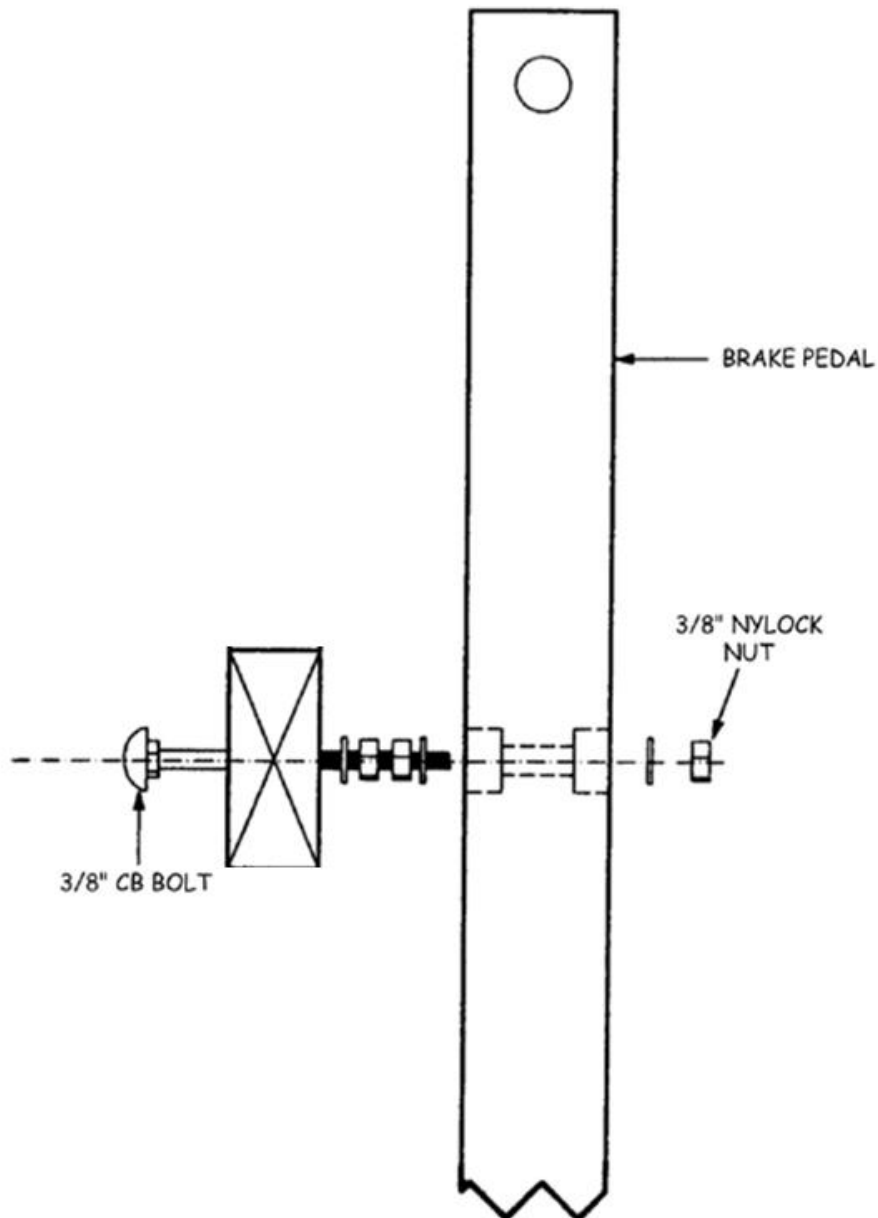
## INSTALL THE BRAKE PEDAL

- 1) If you will be using a single beam, you'll want to mount the Brake Pedal on the left side of the loom. If you have two warp beams, you'll need to mount two pedals; one left, one right.
- 2) Please locate the Brake Pedal assembly or assemblies.
- 3) Remove and set aside the nut, washer, and carriage bolt. Leave the smaller bolt assembly at the end of the pedal in place.
- 4) Find the Brake Pedal mounting hole in the diagram. It is located on left castle (#16), just above the bottom horizontal (#11).



- 5) From the outside of the Left Castle (#16), insert the carriage bolt into its hole. Use light hammer taps to seat the bolt head in the wood.

- 6) Push the Brake Pedal onto the carriage bolt so that the longest part of the pedal is to the front of the loom. Add the washer (it should just fit the recess) and the nut, and snug down with a 9/16" socket.



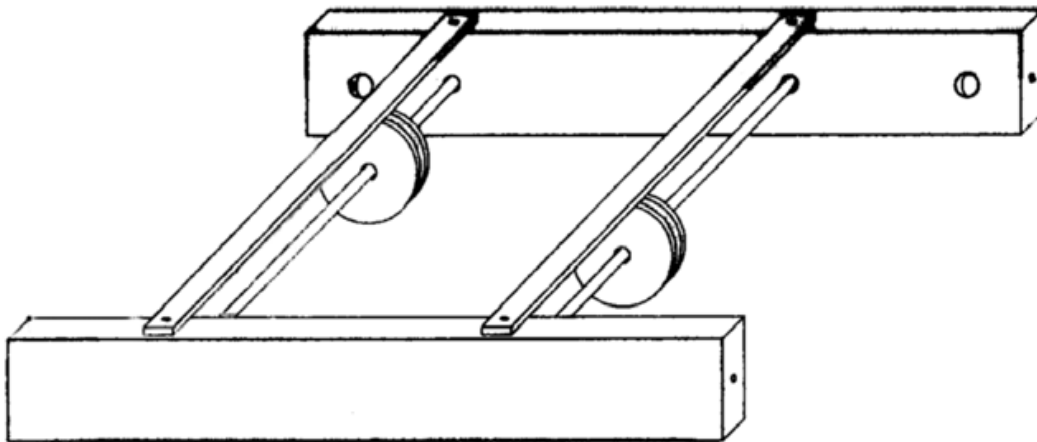
**Figure 14 - Brake Pedal Mounting Hardware**

- 7) If you have a second pedal, mount it now to the opposite side frame.

---

## INSTALL THE TREADLE PULLEY SUPPORT ASSEMBLY

- 1) Collect four more of your mounting bolts and remove the nuts.
- 2) Locate the Treadle Pulley Assembly and bring it to the loom (it has two cross members, two large wooden pulleys on axles, and two black metal straps).

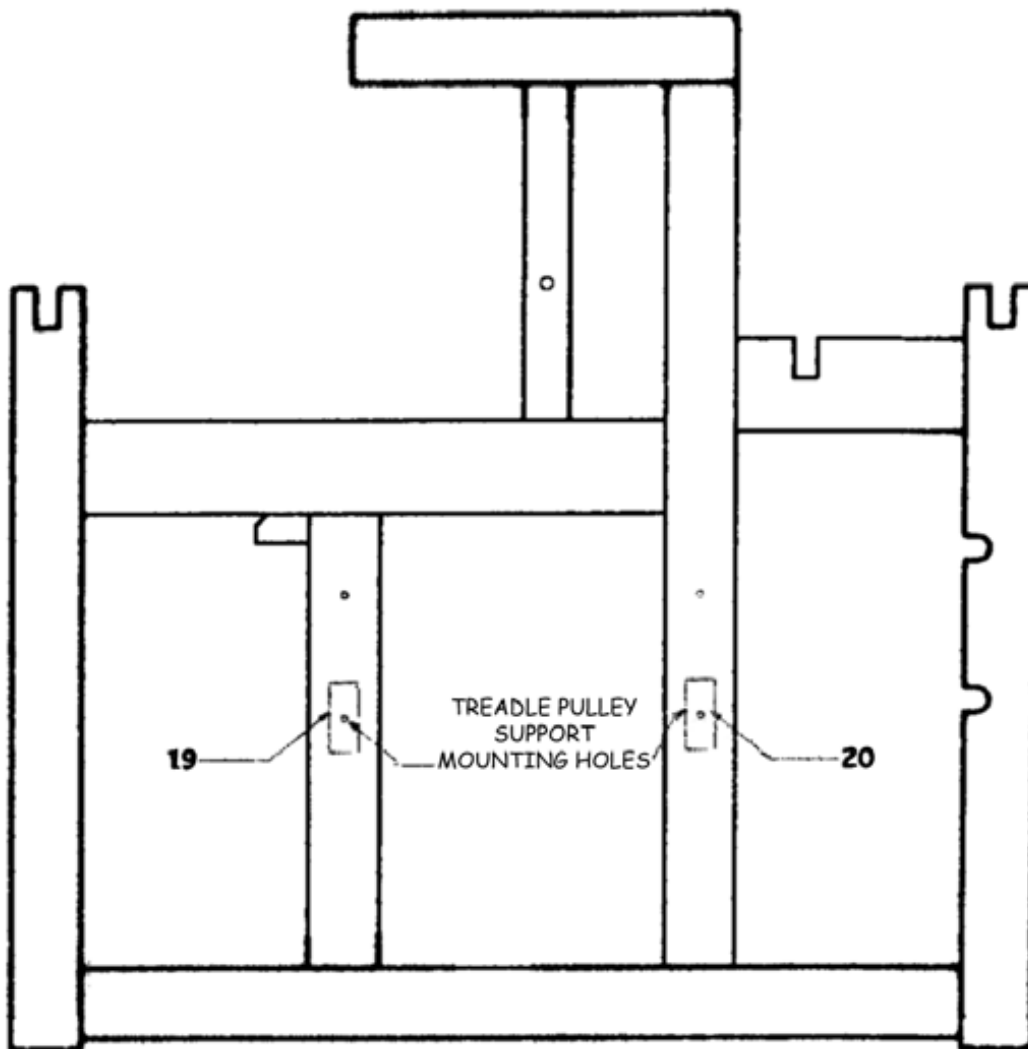


**Figure 15 - Treadle Pulley Support**



**NOTE:**

This assembly has a definite left/right, up/down orientation. The metal straps indicate the top: when in place, there is more distance between the left pulley and left side frame, than the right. From the front of the loom, the short side of the Treadle Pulley Support Assembly goes to the right.



**Figure 16 - Treadle Pulley Support Mounting Holes**

- 3) Consult the diagram to determine the attachment location; then, place the bolts in the frames.

- 4) Once you've correctly oriented the assembly, bolt it into place.

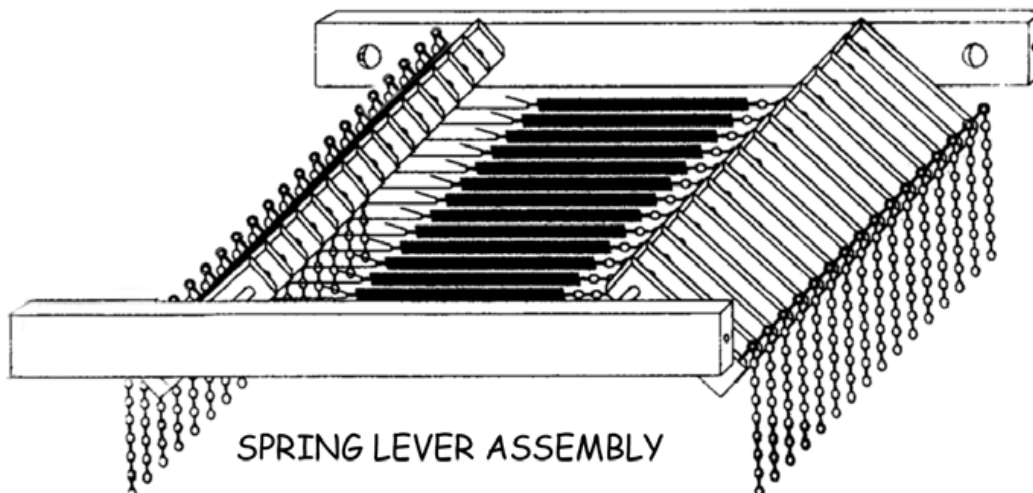


**Figure 17 - Treadle Pulleys**

- 5) Leave the assembly mounting bolts loose enough that you can spread the frame about 1/4". This will facilitate placement of the Spring Lever Supports.

## INSTALL THE SPRING LEVER SUPPORTS

The Spring Lever Support mounts a few inches above the Treadle Pulley Support you just installed. It consists of two cross members and two axes, this time carrying a series of 32 or 48 hooked levers with chains.

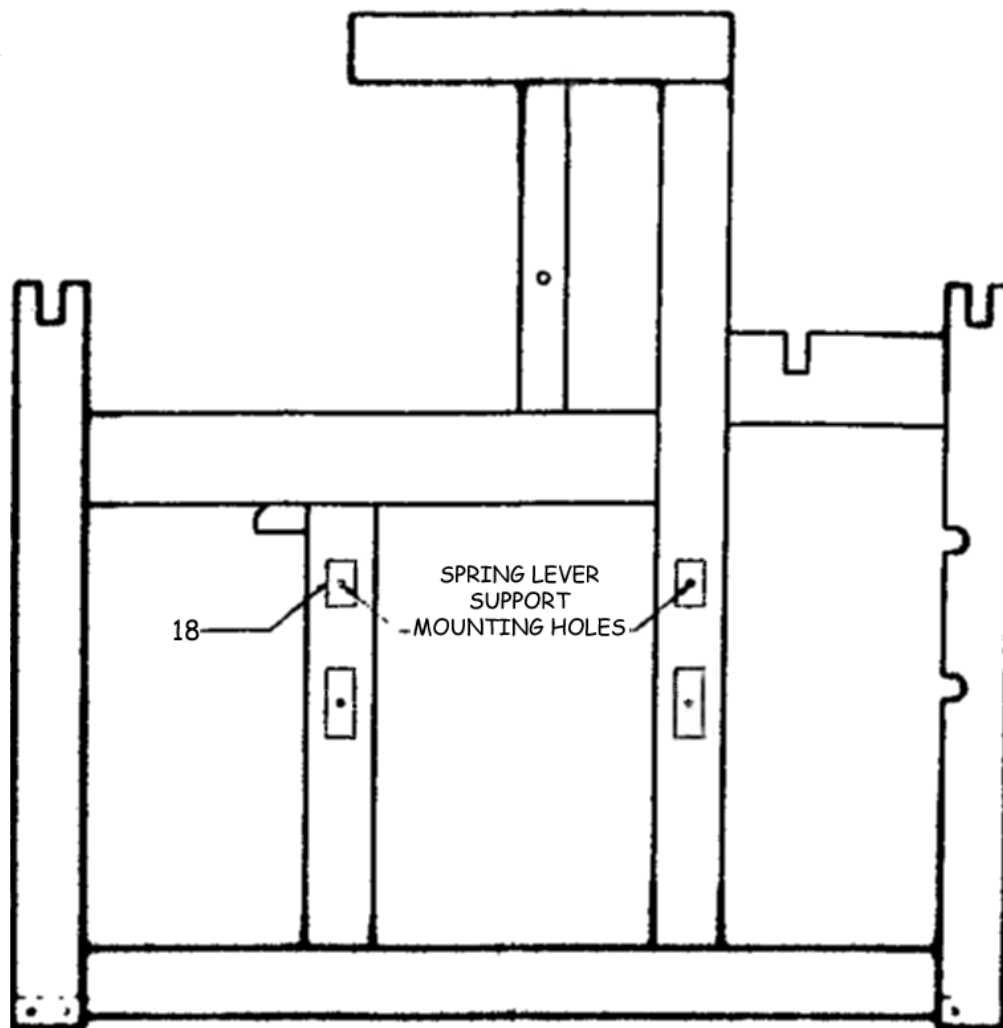


**Figure 18 - Spring Lever Assembly**

**Note:**

Again, there is a definite orientation that must be observed. If you examine the assembly closely, you'll note that half of the levers on each side are shorter than the others. **THE SHORT LEVERS GO TO THE FRONT!**

- 1) Find four more bolts and use them to attach the spring lever assembly to the loom.



**Figure 19 - Spring Lever Support Mounting Holes**

- 2) Return now and tighten the Treadle Pulley Support bolts.
- 3) Before you proceed, you'll want to neaten the Spring Levers. The **left** spring levers simply hang. Disengage the brass hooks so that they all point to the interior of the loom. The **right** levers will rest atop the right-most metal strap. Here, too, deploy the hooks so that they all point to the interior of the loom. Allow the chains to hang.

## SQUARING THE COMPLETED FRAME

Now that you have completely assembled the Loom Frame, it is time to make sure that the frame is square and level.

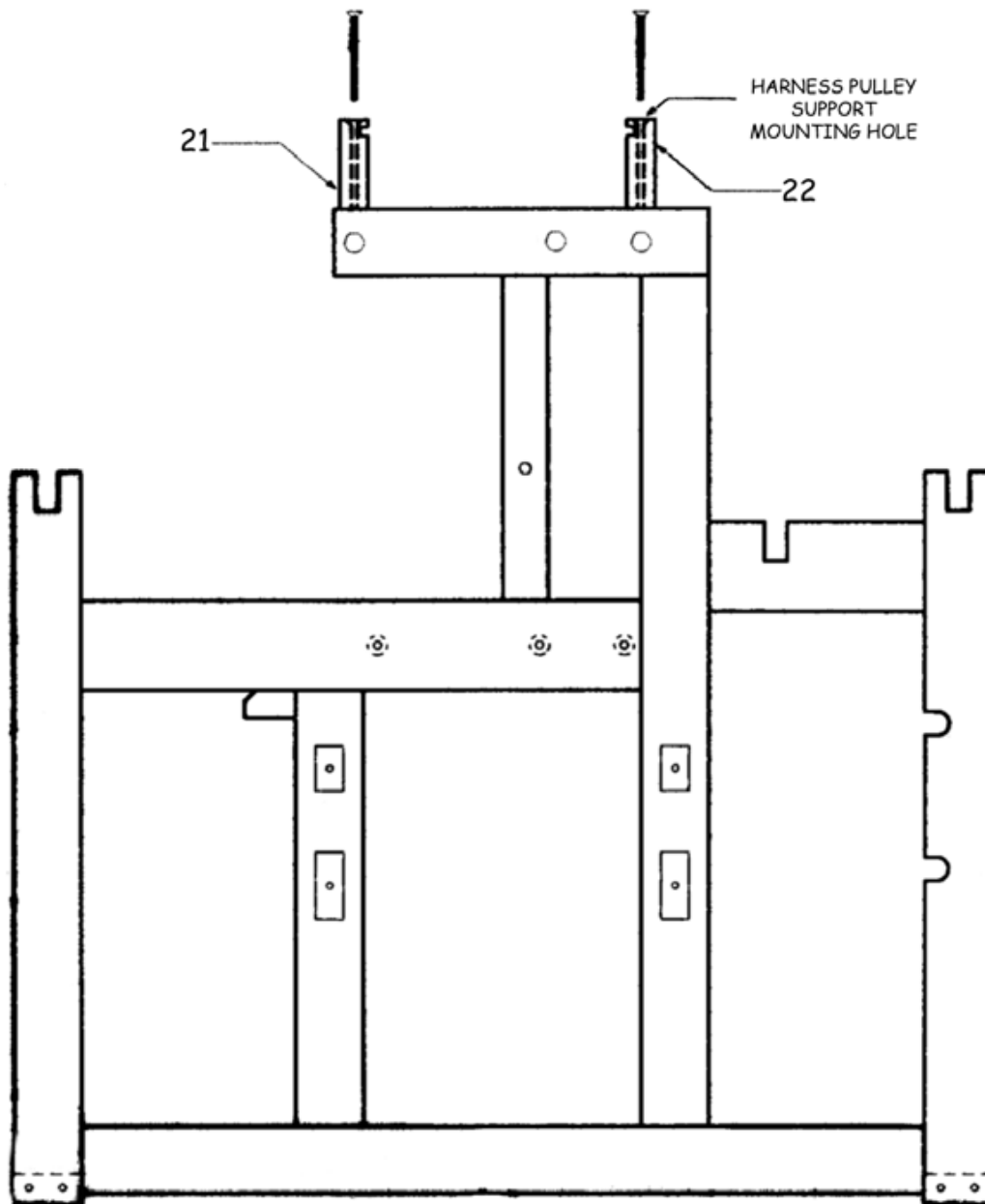
Please make a note of this process, as it is an important part of the maintenance of your loom. Your loom will perform better and give more years of service if this process becomes a part of your regular loom maintenance.

- 1) Using a tape measure, note these measurements:
  - a. The distance from the inside corner of the Rear Left Vertical (5L) to the inside corner of the Front Right Vertical (2R).
  - b. The distance from the inside corner of the Rear Right Vertical (5R) to the inside corner of the Front Left Vertical (2L).
- 2) These two measurements should match. If they do not, you will need to adjust the frame slightly, by pushing and pulling at the corners, until they do match. The Frame will then be square.
- 3) Now, using a level, check the verticals at the corners and the cross pieces at bottom and top. Depending on the flooring, you may need to use shims under the four corner verticals in order to achieve level.
- 4) Once the loom is square and level, check and tighten all bolts and nuts that connect the frame pieces.

Over time, due to the shaking and movement the loom experiences during use, these connections will shake loose, requiring periodic checking and tightening. Make a check of these components a regular part of your loom maintenance.

## INSTALL HARNESS PULLEY SUPPORT ASSEMBLY

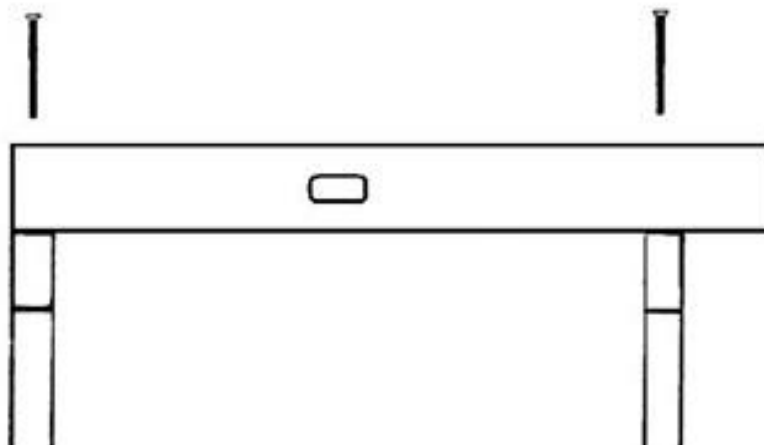
- 1) Locate the assembly. It consists of two cross-members with three sets of pulleys between them.
- 2) Locate the mounting holes on the loom.



**Figure 20 - Harness Pulley Support Mounting Holes**

- 3) From your hardware pack, select 4 — 1/4" x 5- /2" Flat Head Machine Screws and 4 — 1/4" Square Nuts.

- 4) Lay the Harness Pulley Support Assembly atop the loom frame. It should overhang about 4" on the right side.



**Figure 21 - Harness Pulley Support Assembly**

- 5) Cut and carefully remove the packing tape.
- 6) Align the holes in the Pulley Supports with those in the Top Horizontals.
- 7) Insert the Flat Head Machine Screws, add the Square Nuts, and tighten.

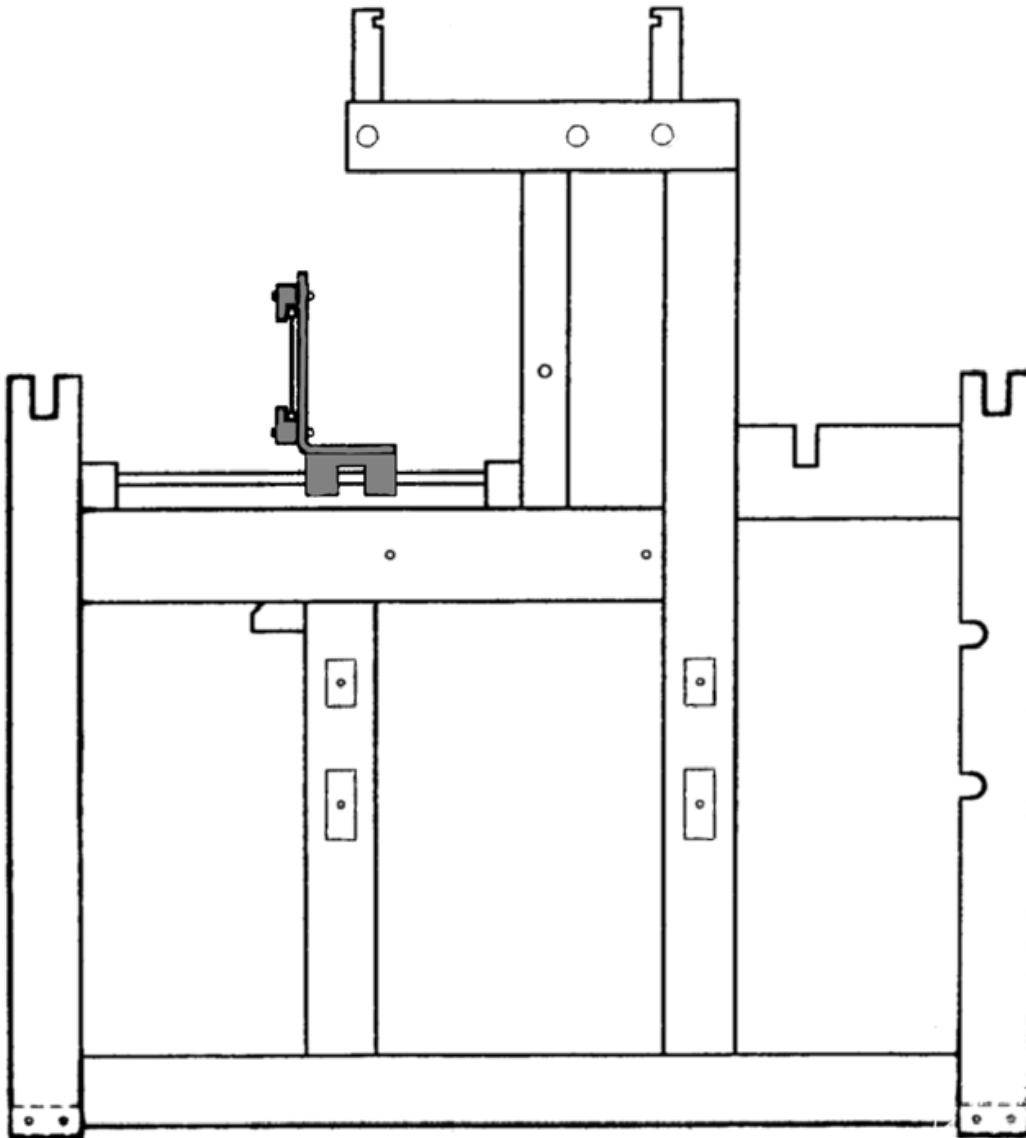
## INSTALL THE BEATER ASSEMBLY

AVL provides two beater options: a Swinging Beater or a rail mounted Sliding Beater. Follow the directions that are appropriate to your system. Both systems are quite easy to install.

### Install the Sliding Beater

- 1) This is one of the last major assemblies. It consists of a beater attached to two metal rods. Please bring it to the loom.
- 2) Attached to the assembly are bags with mounting hard-ware. In them you will find Beater Mounting Blocks (4), 3/8" x 3" Flat Head Machine Screws (2), 3/8" x 6" Flat Head Machine Screws (2), 3/8" Square Nuts (2), and 3/8" Nylock Nuts (2).

- 3) Consult the diagram to determine the proper beater orientation.



**Figure 22 - Sliding Beater Orientation**

- 4) Each Mounting Block is labeled with an identifier. Position the blocks on the ends of the Beater Slide Rods according to these identifiers. The large countersunk holes in each block should be oriented to the top.
- 5) Drop the longer screws into the rear blocks, the shorter into the front.
- 6) Carefully position the assembly atop the Mid Front Horizontals (# 2, #13). With a little jiggling, the screws will fall into the mounting holes.

- 7) Apply the square nuts and tighten them most, but not all the way, down.

**Note:**

To complete the installation of the sliding beater, you need a partner. If no one is available right now, leave the beater as it is and come back to adjust it later.

- 8) Slide the beater all the way forward so that the leather bumpers are equally compressed. Hold the beater in this position and tighten the two front screws most of the way.
- 9) Push the beater all the way back and tighten the back screws most of the way.

**Note:**

You may need to perform this back and forth action several times, making minor adjustments as you go. The point, of course, is to put the Beater Slide Axles in exact parallel.

- 10) Once you have the beater completely square front and back, tighten the screws down completely.

When you're finished, the beater should slide easily along the full length of its travel.

## Install The Swinging Beater Assembly

You may choose for the SDL to be equipped with a Bottom Swing Beater instead of the sliding beater.

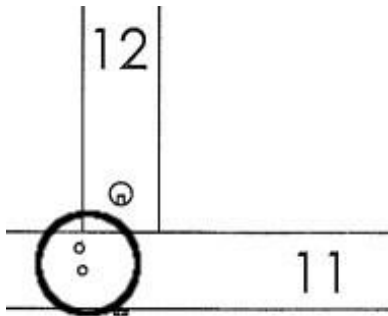
- 1) Locate the box containing the Beater Assembly. Attached to the assembly are bags with mounting hardware.

Beater Supports	2
Shuttle Race	1
Beater Top	1
Beater Legs	2
Reed	1
Hardware Package	1

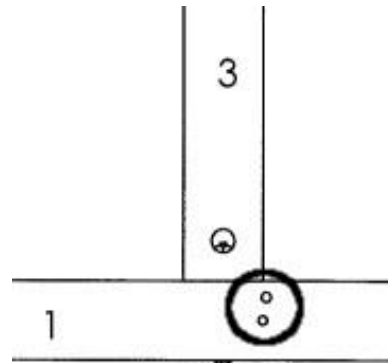
- 2) Locate the two Beater Supports.



- 3) There is one pre-drilled hole on each Lower Horizontal, #1 and #11, just below and forward of where the Verticals, #3 and #12, meet the Lower Horizontals.

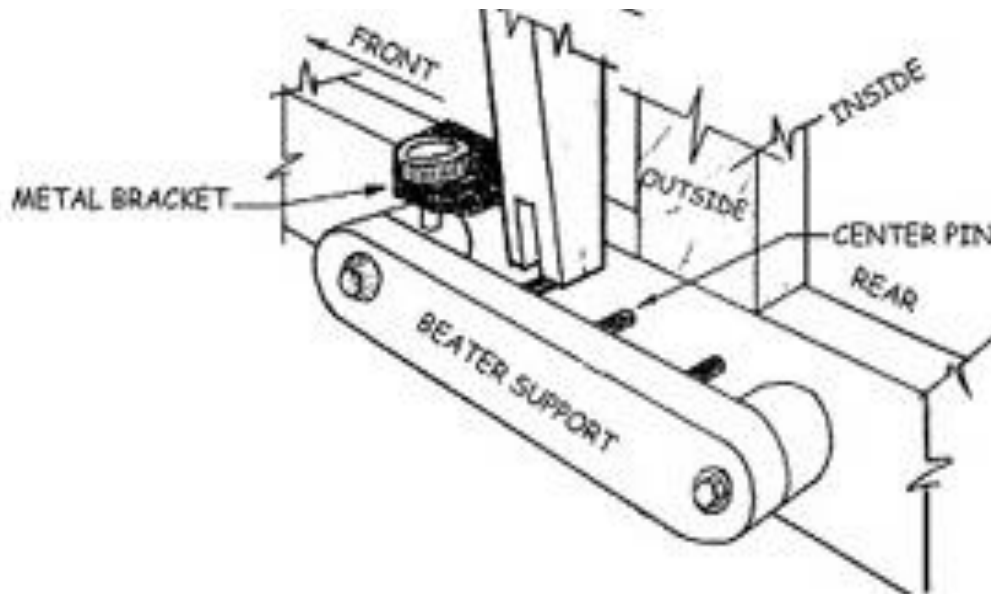


**Figure 23 - Left Beater Support Hole**



**Figure 24 - Right Beater Support Hole**

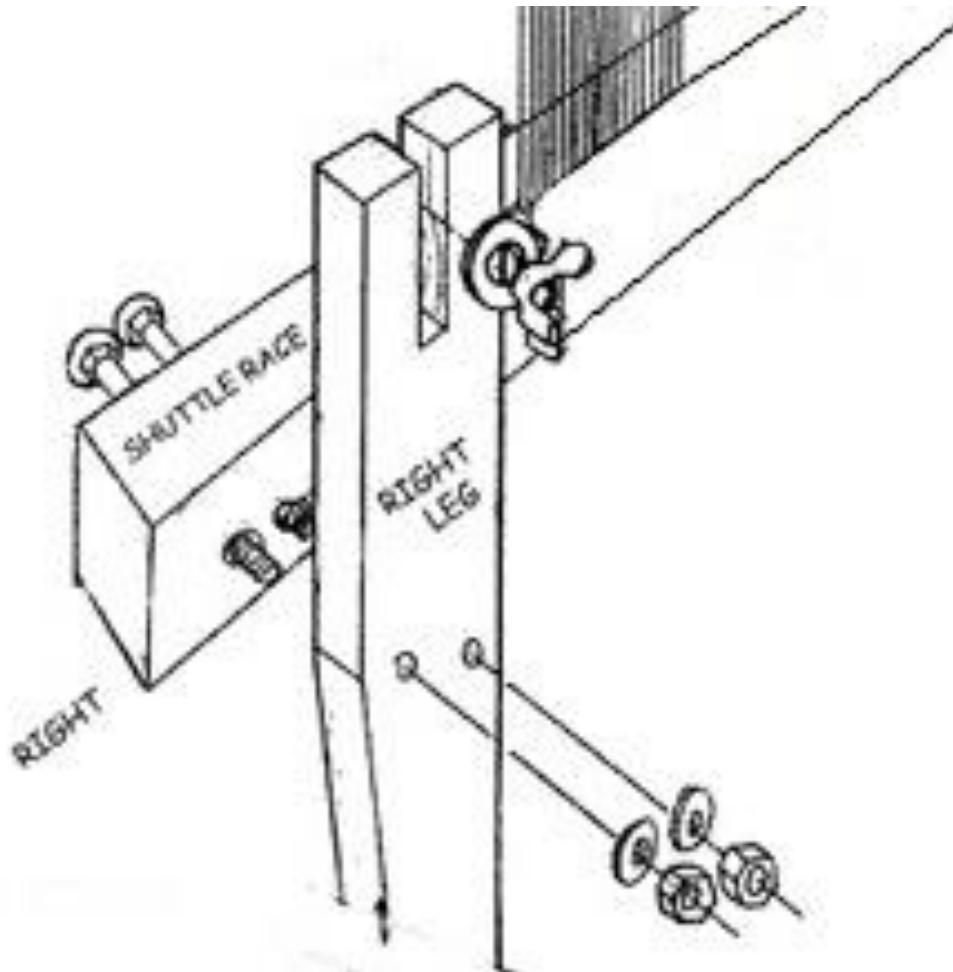
Orient the support so that the support is placed on the loom as shown. The spacer with the threaded rod and metal bracket should face the front of the loom. The metal bracket will overlap the Lower Horizontal.



**Figure 25 - Beater Support**

- 4) The Rear spacer of the support has a bolt already installed. Remove the lock nut and washer from it and insert the bolt through the right Lower Horizontal.
- 5) Slip the washer and nut back on and tighten the nut just to the point where it almost cinches the two parts together. Leave it a

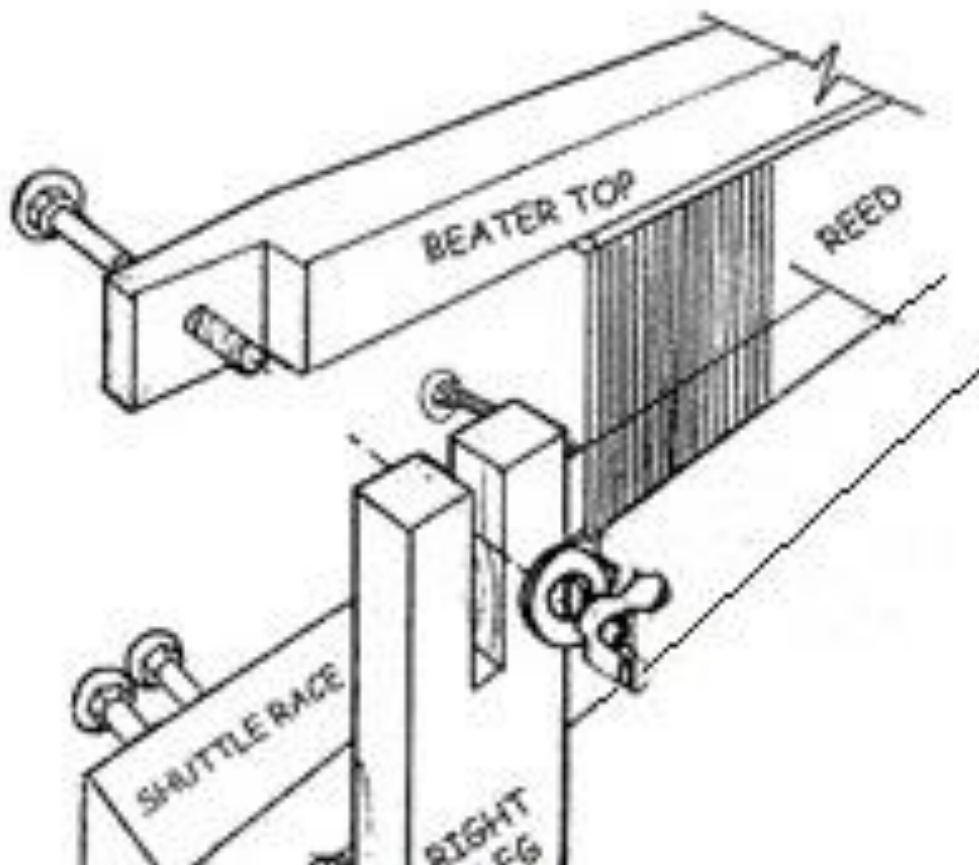
- little bit loose so that the Beater Support can pivot during adjustment.
- 6) Locate two 1-1/2" long screws located in the beater hardware package. Position the metal bracket at the front of the Beater Support over the two pre-drilled holes in the Lower Horizontal (#1, #11) and insert the screws. Tighten them down.
  - 7) Repeat these steps for the other side.
  - 8) Once both Beater Supports are in place, rest the Shuttle Race on the Horizontals, #7 and #13, above the Beater Supports. The lengthwise groove that runs along one side should be at the top and facing toward the rear of the loom.



**Figure 26 - Beater Leg**

- 9) From the hardware bag choose the four 1/4" x 2-3/4" carriage bolts with washers and hex nuts.

- 10) Now locate the Beater Legs. They are marked to show left and right. Place the bottom slot of each leg on the center pin of the Beater Support so that the tapered side of each leg faces away from the loom.
- 11) Line up the holes in the shuttle race with the corresponding holes in each leg and insert the bolts from the front of the race. Attach the washers and nuts and tighten **only slightly**.
- 12) Center your reed in the slot.



**Figure 27 - Beater Top**

- 13) Place the Beater Top on the reed so that the groove is facing down and the cut outs at either end are facing toward the rear of the loom.
- 14) Line up the holes in the Beater Top with the slots in each leg and insert the bolts from the front of the Beater Top. Attach the washers and nuts and tighten **only slightly**.
- 15) Center the Beater Assembly in the loom.

- 16) Place a level in the center of the race and adjust the height of each side, using the black adjustment knob at the metal plate on the Beater Support. These enable you to raise or lower the race on either side, to ensure the race is level.
- 17) Once the race is level, hold the Beater Top at its center and push the Beater all the way back, to meet the Beater Bumpers. Ensure that both sides of the Beater are touching the bumpers.
- 18) Check that the legs are spaced equally from the outer sides of the loom. Adjust as needed, with slight horizontal movements to the Beater Top. This ensures that the legs will not rub on the loom frame.
- 19) Hold the Beater against the bumpers and tighten the bolts that attach the Beater Legs to the Shuttle Race and the Beater Top to the legs.

**Note:**

**There are three steel pins in the Beater support that allow you to adjust the angle of the race. Just lift the beater and replace it over another set of pins. Be sure both sides are on matching pins.**

## INSTALL THE DOBBY HEAD

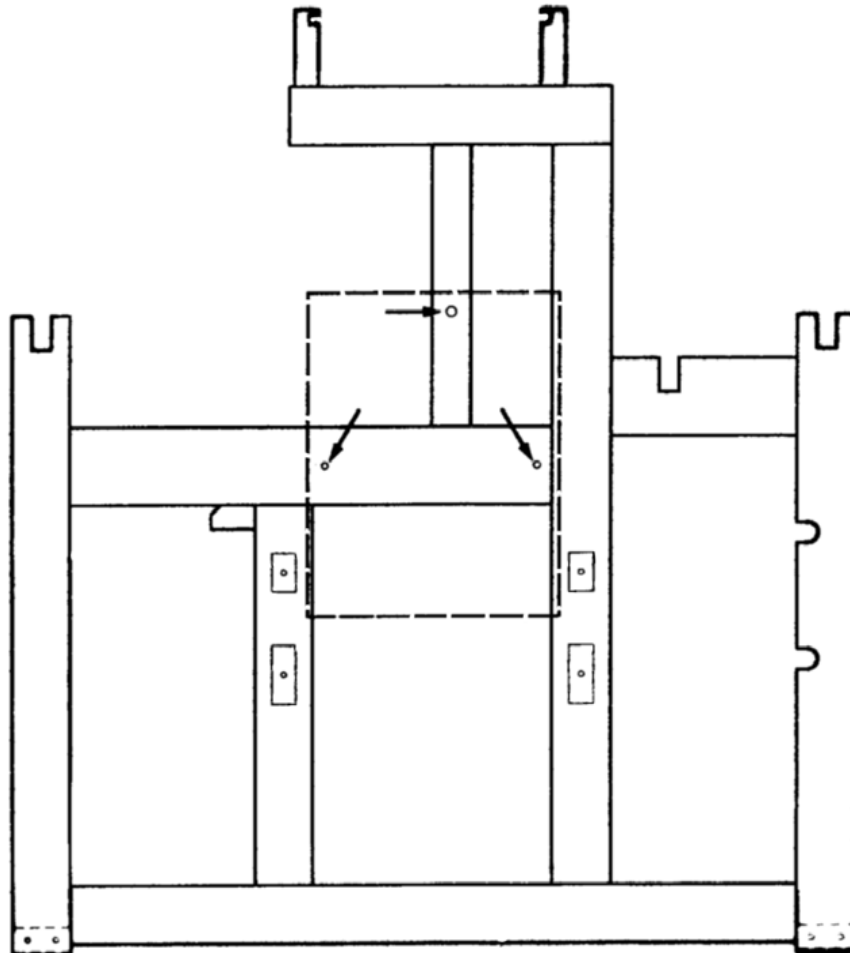
Your Compu-Dobby is made of two parts:

- 1) The Dobby Head –This is the mechanical side of the Dobby; where the Dobby Cables, and Dobby Fingers are located.
  - 2) The Compu-Dobby – This is the electrical side of the Dobby; containing the solenoids and processor that enable the commands from your computer to fire the correct solenoids. The Compu-Dobby is shipped in a special, protective box. Please, if at all possible, retain this box, in the event the Compu-Dobby must be returned to AVL Looms for warranty work or servicing.
- 1) Find and unpack the Dobby box. It will contain the Dobby Head with attached Sensor Case and the Dobby Arm Assembly.
  - 2) The Dobby Head hangs from the right side of the loom, at the mid-point on the frame.
  - 3) The accompanying diagram shows the location of the mounting holes. Note that three mounting bolts protrude from the back of the

Dobby Head. If any of these have come loose, you'll need to reposition them from inside the Dobby Box.

**Note:**

The bolt heads are seated in a recess in the wood.



- 4) Remove the nuts and washers from the mounting bolts and carefully slide the Dobby Head into position on the loom frame.
- 5) From inside the frame, slip a washer onto each bolt end, then thread on a hex nut. Tighten with a 1/2" socket.
- 6) Remove the hardware and wooden spacer from the pivot end of the arm.
- 7) Slide the Dobby Arm into the large window in the left side of the Dobby Head. Push it through until the magnet end sticks an inch or two through the slot on the right side of the head. Don't worry for

the moment about cable alignments — we'll straighten all that out later.

- 8) Use a 1/2" socket to bolt the Dobby Arm into the Front Mid Horizontal.



**Figure 28 - Dobby Arm**

- 9) By hand, move the Dobby Arm up and down. Check that the magnet clears the Dobby Arm. If not, loosen the screws on the sensor and adjust it so that the magnet clears.

## HARNESS ASSEMBLIES

It's time to add some of the muscle and sinew to your loom: the harness cables, harnesses, and harness springs. If you ordered your loom with Polyester heddles, you'll need to assemble your harnesses now. Please follow the directions below.

If your loom is equipped with metal heddles, proceed immediately to step 1 of the harness installation instructions.

## Polyester Heddles

The polyester heddles come attached to each other and will need to be cut apart. The heddles are shipped in bundles of 100. There are two twist ties on the bottom and two twist ties on the top.



**Figure 29 - Polyester Heddle Bundle**

These go through the space for the harness. Do not remove the twist ties until you have placed the heddles on the harness. They will keep the heddles properly contained until they are on the harness.

**Note:**

**You will need to cut the bundle of heddles apart. You can do that either before you place them on the loom, or after.**

### Break up Heddle bundles

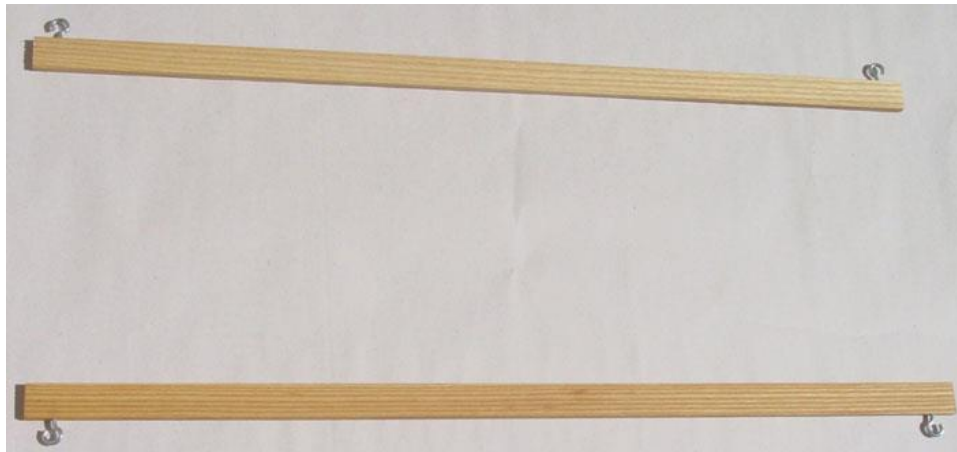
Our heddles come in bundles of 100. You will need to break them up into smaller bundles before you put them on the loom. Your loom comes with 25 heddles per harness. If you need additional heddles, you can buy them in bundles of 100 from us.

- 1) Leave the twist ties on, and count out the number of heddles you want.
- 2) Put new twist ties around the smaller bundle.
- 3) Place enough ties so that all the heddles are contained before removing the original twist ties.

---

## Make Polyester Harness Assemblies

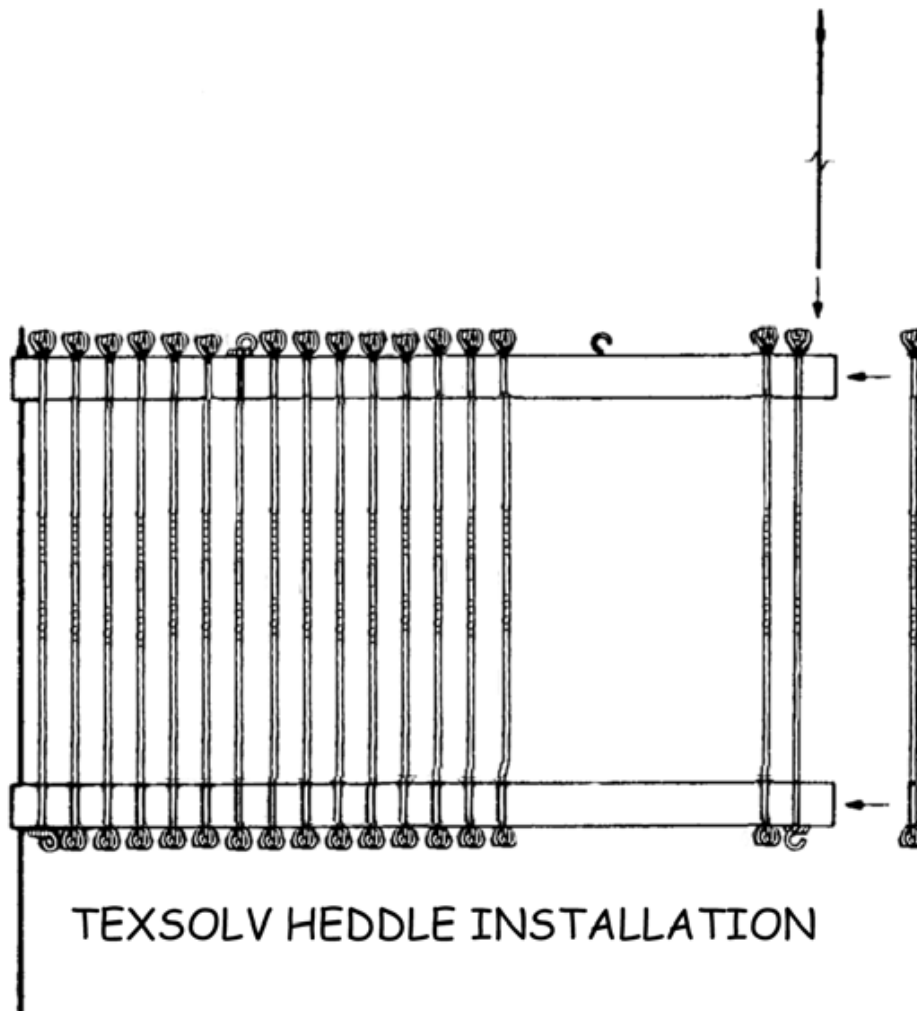
- 1) Locate the Harness Sticks, Harness Wires, and Polyester heddles.
- 2) The sticks are divided into two groups: the top sticks have hooks that are spaced closer together. The hooks in the bottom sticks then, are farther apart.
- 3) Select one top and one bottom stick. Lay them on a table top parallel to one another, about 12" apart. Orient them so that the hooks point top and bottom.



**Figure 30 - Parallel Harness Sticks**



- 4) Select two Harness Wires and slide one through the end hole of the top stick so that the copper fitting at the end of the Harness Wire is at the top. Insert the blank end of the wire through the end hole of the bottom stick.



**Figure 31 - Polyester Heddle Installation**

- 5) Thread 25 heddles onto the sticks from the open end of the harness assembly (we provide 25 heddles per harness).



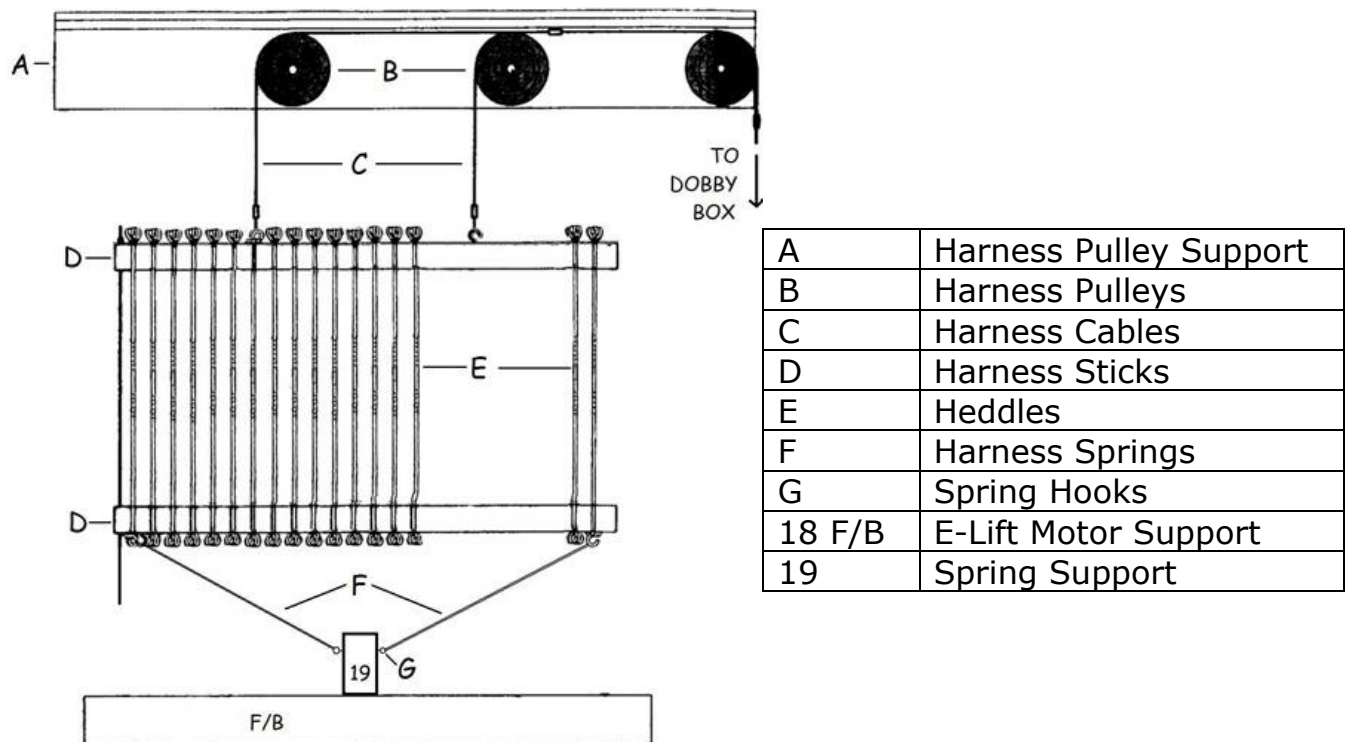
**Figure 32 - Add Heddles to Harness**

- 6) Add the second Harness Wire.

### **Install the Harnesses**

- 1) Please locate the Harness Frames (if metal heddles) and the Harness Springs.
- 2) The Harness Pulley Box has a top that slides out to give you access to the pulleys.
- 3) Your Dobby Head sports a long mane of bundled cables.
- 4) Please remove the twist ties now and separate them. You'll see that each cable has two terminal ends, a long and a short. Select the first cable, front or rear.
- 5) Now, draw the cable up and over the three pulleys that are aligned with it. The longest end of the cable should hang over the pulley furthest from the Dobby; the shortest leg over the pulley in the between set.

- 6) Check that the cable is not twisted on itself — this will cause problems when you are weaving.



**Figure 33 - Harness System**

- 7) Select a harness frame (metal heddles) or harness stick assembly (Polyester heddles). Either assembly will have two hooks, top and bottom. The hooks that are set closest together are at the TOP of the assembly.
- 8) Hang the harness assembly from the cable you just installed.
- 9) Locate a harness spring. Each of these springs has a chain worked into one end. You will fasten one of these spring and chain assemblies between each set of spring levers (immediately below the harnesses).
- 10) Find the corresponding set of spring levers. Each lever has a brass hook, which pivots on a brass pin. If the hooks are not already hanging free of their slots, pull them out now.
- 11) Link the end of the chain into the hook in either spring lever, left or right. Attach the spring end onto the hook in the opposing lever.
- 12) Lastly, hook the spring lever chains into the small hooks at the bottom of the harness. If you are using Polyester heddles, the

frames will be unstable until you completed this connection: managing them is frustrating, but certainly not impossible.

- 13) You've now installed one complete harness assembly. Go back and repeat steps 3 through 11 for each remaining harness. Check your work periodically; it's easy to connect the wrong harness into the wrong set of levers.

## INSTALL THE WARP BEAM

The loom is designed to carry two Plain Warp Beams or a single Sectional Beam. Plain beams may be used in either the upper or lower position; however, a sectional beam may only be mounted in the upper position.

If you intend to use two beams simultaneously, an additional assembly needs to be fixed to the Rear Verticals. If you are using a single beam, put it in the upper position.

- 1) Locate your Warp Beam and mounting hardware.
- 2) Loosen the bolt on the beam retainer.



**Figure 34 – Beam Retainer**

- 3) Bring the warp beam into position. If you are using the upper location, orient the beam so that the long end of the axle extends to the left of the loom (opposite the Dobby Head).
- 4) Seat the beam in the axle pockets.

- 5) Replace the beam retainers into position and tighten the bolt.
- 6) Locate the Warp Beam Handle and remove its hardware.
- 7) Slip the handle over the protruding end of the beam axle, insert the bolt, and secure with the washer and nut. Note that the handle is connected with a carriage bolt, the head of which must fit into its stamped recess.



**Figure 35 - Warp Beam Handle**

- 8) The upper beam should be oriented so that the handle is on the left side of the loom. Follow the same procedure to mount a lower beam. The lower beam will be oriented so that the handle is on the doobby side of the loom.

**Note:**

**You may only use a single Sectional Beam. It may only be mounted in the upper location.**

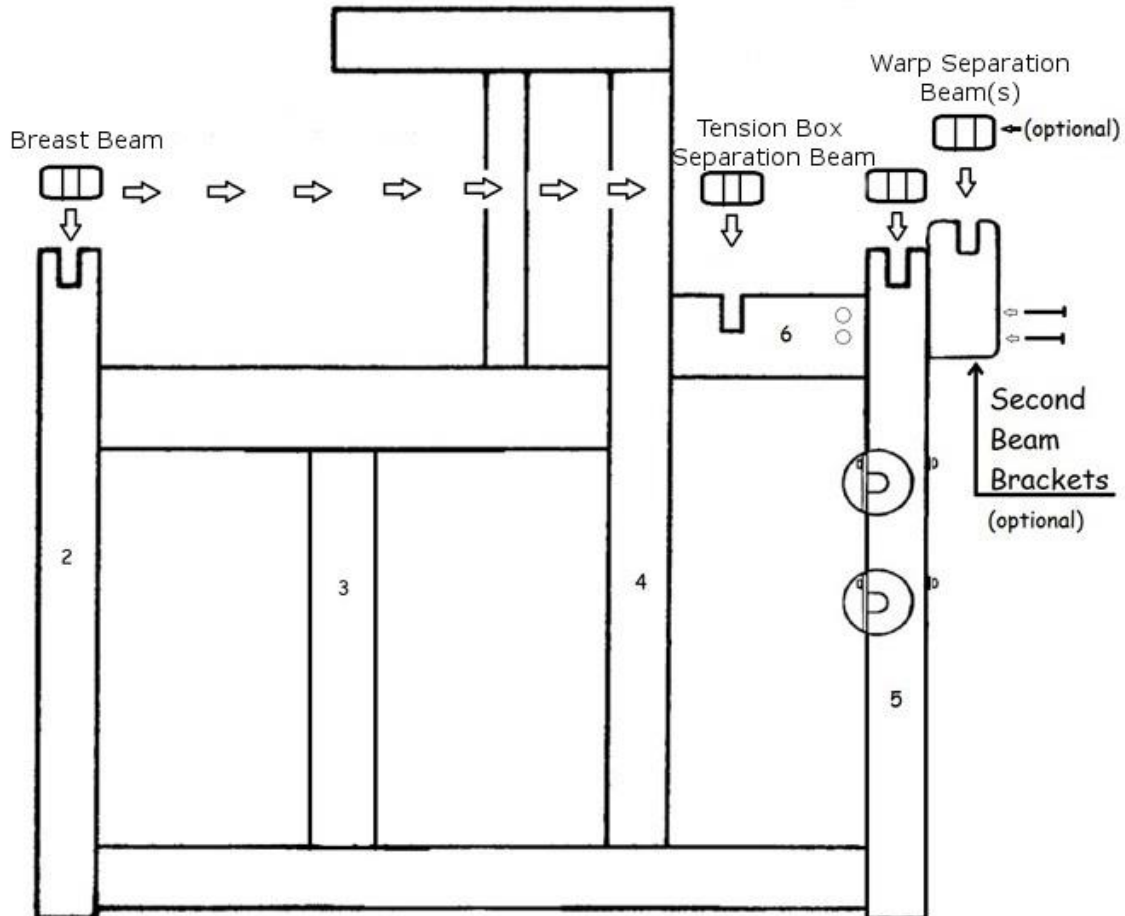
### **Installation Of The Breast Beam And Separation Beam**

You will have one breast beam that can also be used to wind-on from a tension box.

- 1) To use as a breast beam, place it with the groove down in the cutouts at the front of your loom.
- 2) To use the breast beam to wind on, place it groove up in the slot in #6 & 6A near the back.

You will have a separation beam for each warp beam. These are identical to the breast beam.

- 3) Place the beam for the upper warp beam in the slots in #5.



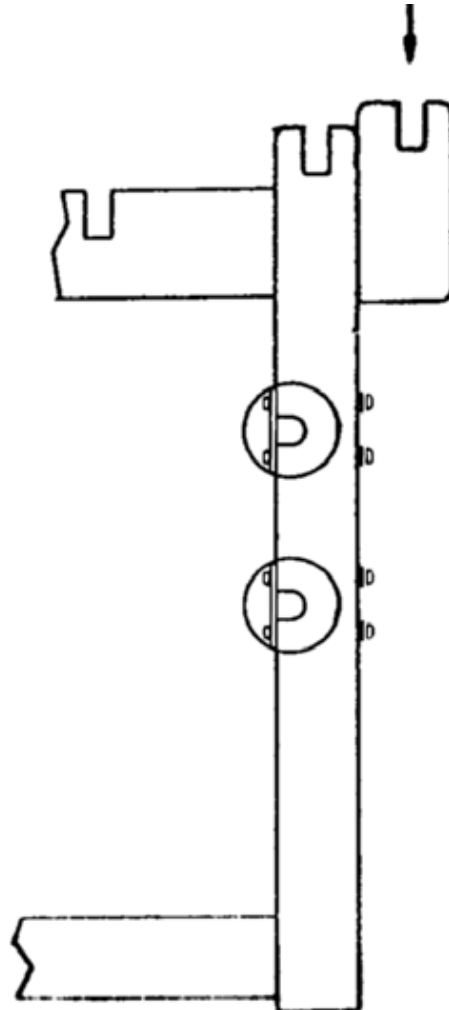
**Figure 36 - Breast Beam and Separation Beam Locations**

### Second Warp Beam Brackets

As noted above, if you intend to use two warp beams in your weaving, you'll need to attach an extra set of brackets to the Rear Verticals. These Warp Beam Brackets support an additional cross member which is used to direct your warp to the harnesses.

- 1) Select the Warp Beam Brackets. They are identical, so you needn't be concerned about left and right.

- 2) As shown in the diagram, these brackets bolt into the top of the Rear Verticals.



**Figure 37 - Second Warp Beam Brackets**

- 3) Remove and save the two bolts that connect each vertical to the Middle Rear Horizontal.
- 4) We've already positioned the bracket mounting bolts in the brackets. Remove the square nuts from the bolt ends, push the brackets into place, and tighten with a 1/2" wrench.
- 5) You will have received an extra Breast Beam. In this case, it will act as a Warp Separation Beam. You may place it in the bracket pockets now or wait until you dress the loom.

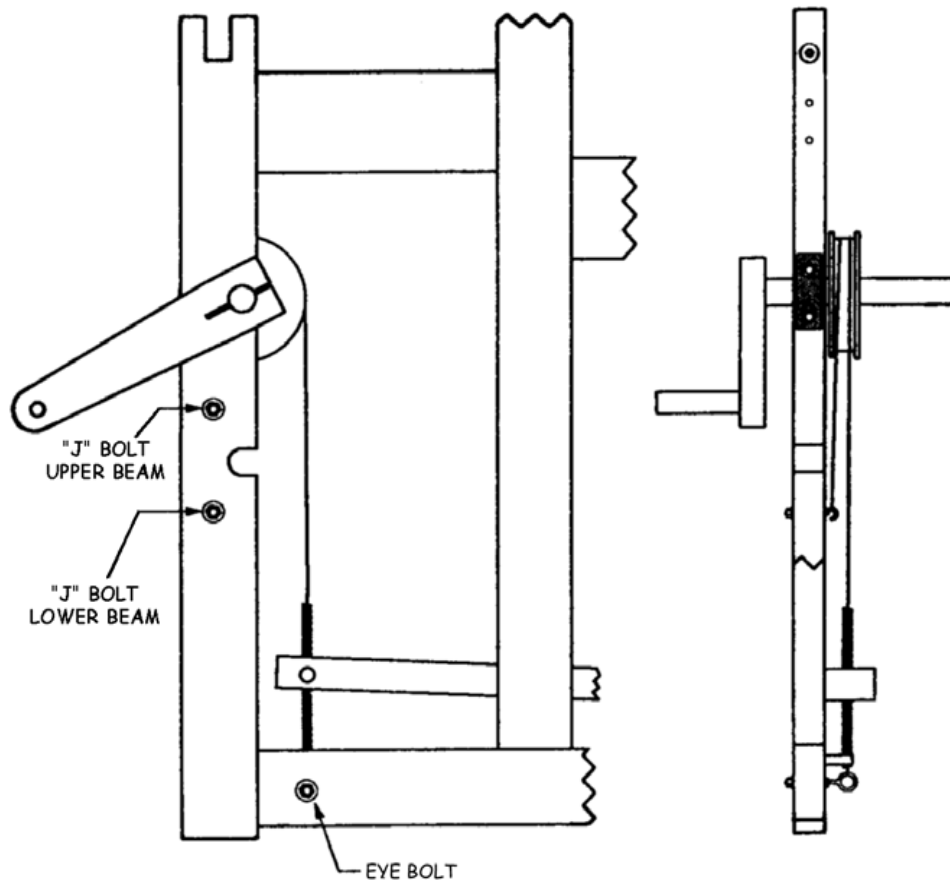
## Mount the Brake Cable System

You've already installed your Brake Pedal(s), now you need to add the cables and springs.

Brake cables come in different lengths, depending on the type of beam you're using, and its location. Your cable assemblies are individually bagged and marked, but if you become confused, consult the table below.

Beam Type	Cable Length
Sectional	74 1/4"
Upper Plain Beam	51"
Lower Plain Beam	48"

- 1) Select the poly bag with the appropriate cable assembly. It will contain a Steel brake cable, a Tension Tie-Up with Toggle, a "J" Bolt assembly, and an Eye Bolt/Cord assembly.
- 2) The accompanying diagram indicates the holes for the cable mounting hardware.



**Figure 38 - Brake Cable Mounting**



- 3) Mount the "J" and eye bolts, making sure that each points to the inside of the loom. The "J" bolt should point down so that the opening faces the floor.
- 4) Use a 7/16" wrench to remove the nut from the bolt in the end of the brake pedal, then slide the bolt most of the way out. Find the tension tie-up (the dacron cord with toggle).
- 5) Insert the tip of the bolt through the three strands of cord that create the loop, with the toggle remaining above the pedal.



**Figure 39 - End of Brake Pedal**

- 6) Push down on the end of the brake pedal so that you can attach the spring to the bolt on the brake pedal. You'll have both the tie-up and the spring on the bolt.
- 7) Push the bolt back through the pedal and replace the nut.
- 8) Now find the brake cable. Connect the loop end to the "J" bolt.

- 9) Bring the cable immediately up and around the BACK side of the Brake Drum. Wrap it three times around, taking care **not** to cross the cable on itself.



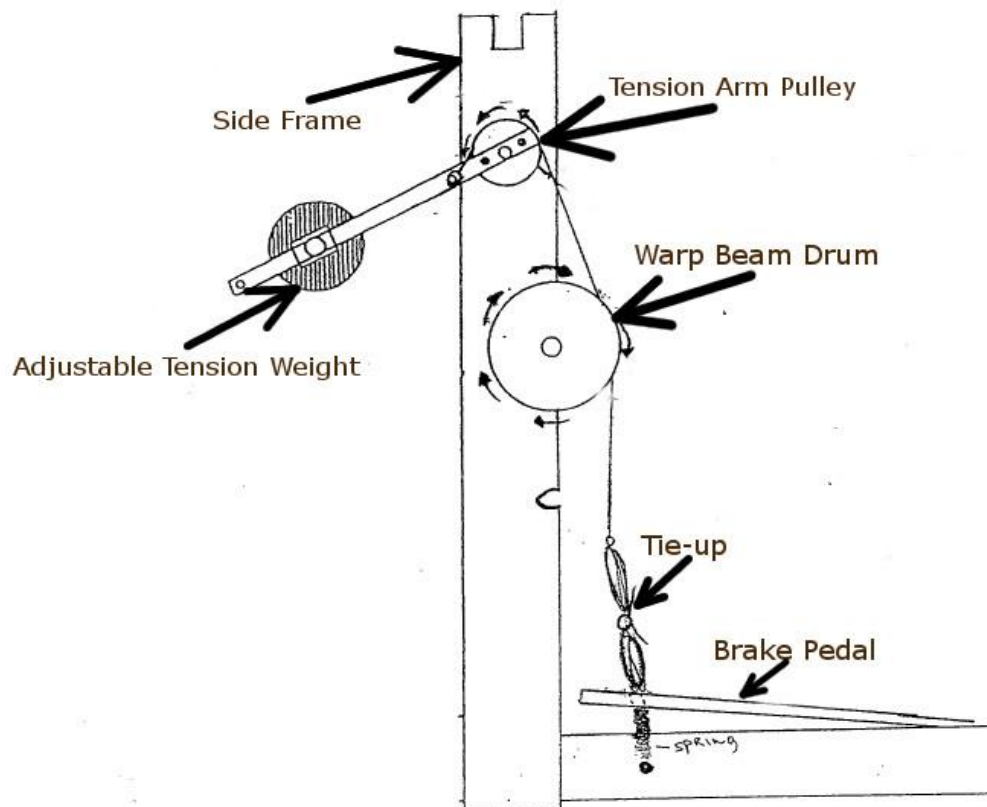
**Figure 40 - Tension Adjustment for Brake Pedal**

- 10) When you've just enough cable remaining to almost reach the brake pedal, use the snap hook at the end of the cable to clip onto the cording (three loops of the cord go into the snap hook).
- 11) Check again to make sure the cable isn't crossed on itself.
- 12) Use the toggle on the tie-up to adjust the tension on the pedal.

### **Install the Optional Tension Device**

If you ordered the optional tension device with your loom, follow these instructions to install it.

- 1) Find the hole in the Rear Vertical (#5) and place the pulley on the tension arm so that the holes match.
- 2) Place the bolt in the hole and tighten.
- 3) Take the brake cable from the brake pedal tie-up 3 times around the warp beam drum, up to the pulley on the tension arm and attach the end to the protrusion on the arm.



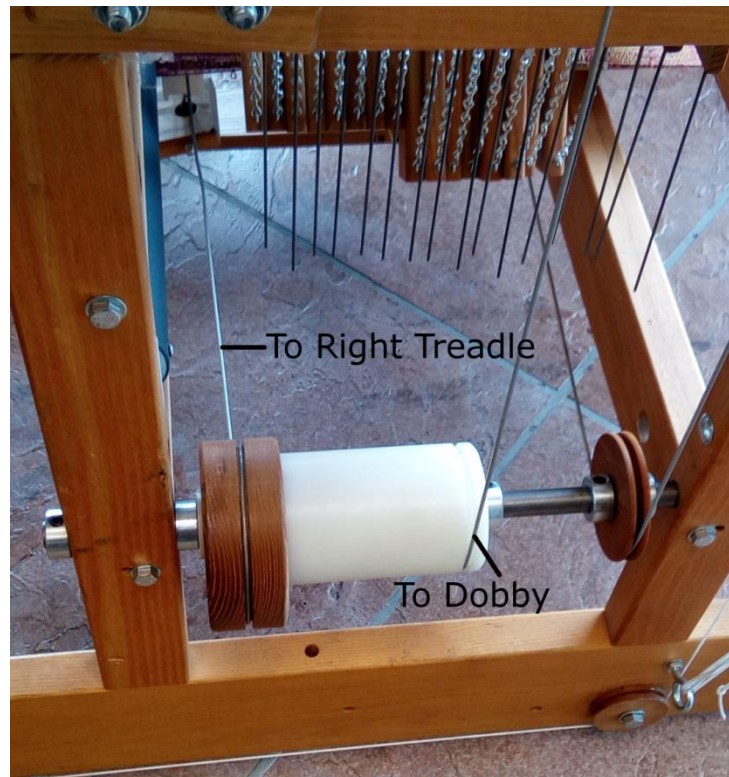
**Figure 41 - Optional Tension Device**

## CONNECT THE TREADLE CABLES

Unless you've already removed the tape from them, you'll find two cables wound around the Dobby Cam Cylinder assembly. These connect to the Right Treadle and the Dobby Arm. The small pulley on the right will be used for the left treadle cable which is hanging from the dobbie.

## Install the Right Treadle Cable

- 1) Remove the tape from the left-most cable that goes around the nautilus shaped part. You'll note that this cable runs through a small hole in the cam. The hole is directional and the cable **must** be threaded around the cam in the direction established by this hole.
- 2) Take the cable end from the bottom of the cam, under the metal retainer and over the Right Treadle Pulley, and down to the end of the Right Treadle.



**Figure 42 - Treadle Cables**

- 3) Remove the bolt from the end of the right treadle, thread the cable onto it and replace the bolt.



**Figure 43 - Treadle Cable Bolt**

- 4) Leave the other cylinder cable taped down for the moment. You'll eventually connect this to the Dobby Arm.

### **Connect the Left Treadle Cable**

- 1) The Left Treadle Cable hangs from the bottom of the Dobby Head. As with the Right Treadle Cable, there is a loop at one end. The other is finished with a small copper barrel.
- 2) Conduct the loop end down from the dobbie, under the slender pulley at the right of the Cam Cylinder assembly, over the remaining Treadle Pulley, and finally to the Left Treadle. Bolt it in.
- 3) Find the end with the copper fitting. You will see a two holes drilled through the upper surface of the Dobby Arm. The one on the left is smaller. You should also find a small bag with cable retainers taped to the arm. Remove the bag and select a cable retainer.
- 4) Make sure the cable is going around the small pulley near the top of the dobbie.



**Figure 44 - Treadle Cable around Dobby Pulley**

- 5) Push the end of the cable through the small hole in the Dobby Arm. Now take the retainer and push it onto the cable so that you can pull the copper fitting into the hollow interior of the plastic retainer.
- 6) From above the Dobby Arm, pull up on the cable and seat the retainer into the pocket drilled in the underside of the Dobby Arm. If you've done your job, you'll no longer be able to see the retainer and the cable end will be firmly connected to the arm.

### **Connect the Cylinder to Dobby Arm Cable**

- 1) Remove the tape from the remaining cable. It, too, comes out a directional hole.
- 2) Wrap the cable around the cylinder and bring it up to the Dobby Arm.



**Figure 45 - Cylinder to Dobby Arm Cable**

- 3) Insert the cable end from the bottom of the arm, up through the larger hole.
- 4) Fix the second plastic retainer onto the cable end and seat it in the arm.

The Left Treadle should hang about two inches below its pulley; the Right Treadle should nearly touch the floor. If this is not what you have, go back over the cable installation procedure and see if you can find the problem. Check, too, that the cables are properly located on their respective pulleys.

## **INSTALL THE SHELF**

You're nearly finished! -- Time to install the shelf.

- 1) Orient the shelf so that the felt strips on the bottom will lay atop the three sets of harness pulleys when the shelf is in place. These act as cable retainers and will keep your Harness Cables properly located when you treadle.
- 2) Slide the shelf into the grooves in the Harness Pulley Supports.

- 3) Insert the Retention Pin into its hole. It will, and should be, tight. It will loosen over time.
- 4) If you cannot push the pin all the way into the shelf, check that you haven't put the shelf in backwards.

## **THE COMPU-DOBBY**

There remains one last assembly operation -- the installation of your Compu-Dobby.

### **General Information**

Several of our looms use the same Compu-Dobby and it has its own manual. You'll refer to this manual from here.

As you work through the directions, you'll find that some instructions are clearly written for other looms. This won't be particularly troublesome; the thrust of the procedure is clear and we'll already have done some of the operations for you. If you become confused at any point, please call our Customer Service number (800 626-9615) and ask for Compu-Dobby support.

Once you've installed and adjusted the Compu-Dobby, secured the cables, and made the computer connections, you will be able to use your loom.

The remainder of this manual is devoted to warping and using your loom. If you are an experienced weaver, we suggest you try our methods for warping the loom for at least your first warp. If you are a new weaver, these instructions will help you start.



# WEAVING INSTRUCTIONS

**Note:**

Unless otherwise noted, the instructions in this section are basic, general instructions for weaving and are applicable to many AVL and non-AVL looms. They should not be regarded as a substitute for training or experience.

## WARPING THE PLAIN BEAM

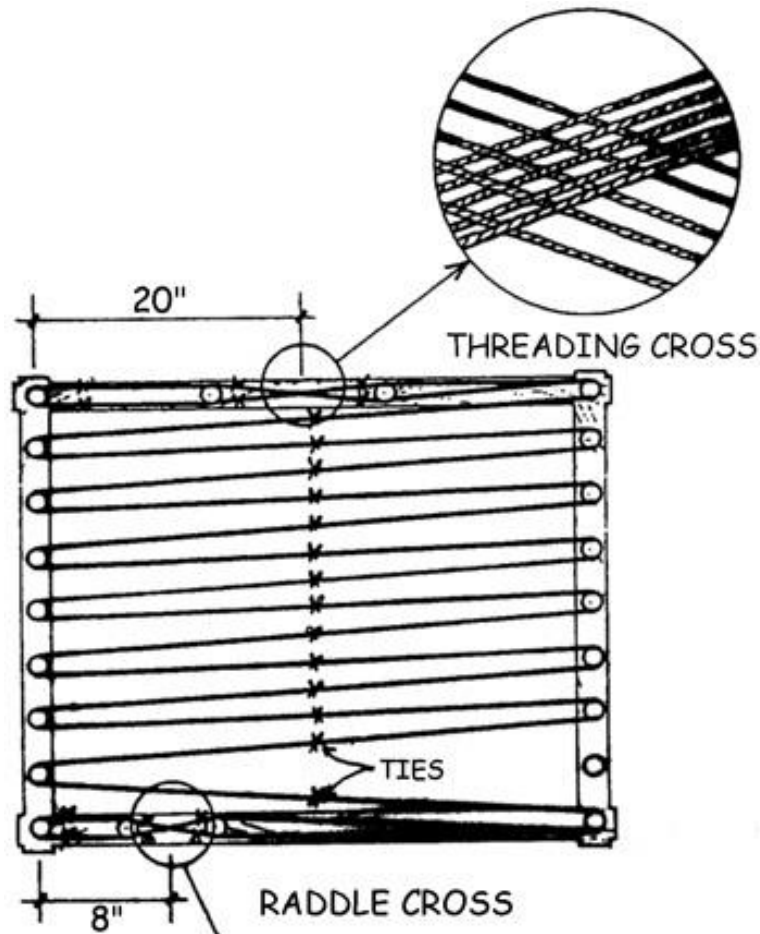
If you only have a Sectional Beam, proceed to the section titled *Warping the Sectional Beam*.

Various warping methods can be adapted to an AVL loom. However, we recommend the following method in which the warp is wound on to the Plain Beam with the use of a Raddle. Please study this method and try it. We have found that it aids in getting a uniform warp tension, especially when dealing with long warps.

### Creating Two Crosses

To begin, wind the warp on a warping board or reel. Make sure you put in two crosses, one at each end of your warp:

- 1) The Threading Cross (each thread crosses the next thread in opposite directions; all are secured in a single loop).



**Figure 46 - Warping Board with Two Crosses**

- 2) The Raddle Cross (warp threads are tied in groups, depending on how many ends will be put in each section of the raddle).

### Securing the Crosses

Before removing the warp from the board or the reel, secure the crosses. Use four ties to secure each cross, in addition to the tie at the cross axis. These ties go on each side of both pegs holding the cross.

It is usually a good idea to use different color threads for the ties on the tops of the pegs and another color to tie the bows underneath the pegs. By color-coding your ties, you are less likely to twist the warp later.

### Removing the Warp from the Warping Board

Remove the warp from the warping board by chaining or by winding on the kitestick. Start from the Threading Cross and proceed to the Raddle Cross.

Since the capacity of the warping board is limited, for wide warps you will end up making a number of mini-warps and taking them off individually.

## **Adjusting the Tension**

Before winding on the warp, check the tension device to make sure the rope is wrapped three times around the tension drum and that the rope end is clipped to the spring, which is held by the Hook Bolt. Test that you are able to turn the Beam in a clockwise direction. If this proves difficult, you can let some length out of the nylon cord by pressing on the toggle button and moving the toggle up and down on the cord. This will allow you to turn the beam backwards during winding and the Beam will be stabilized when at rest. Don't forget to retighten the cord when you are ready to thread the heddles!

## **Attaching the Raddle**

Secure the Raddle to the back of the loom. If you have an AVL Raddle, simply slip the mounting rods into the set of holes in the back of the rear vertical members.

## **Winding the Apron**

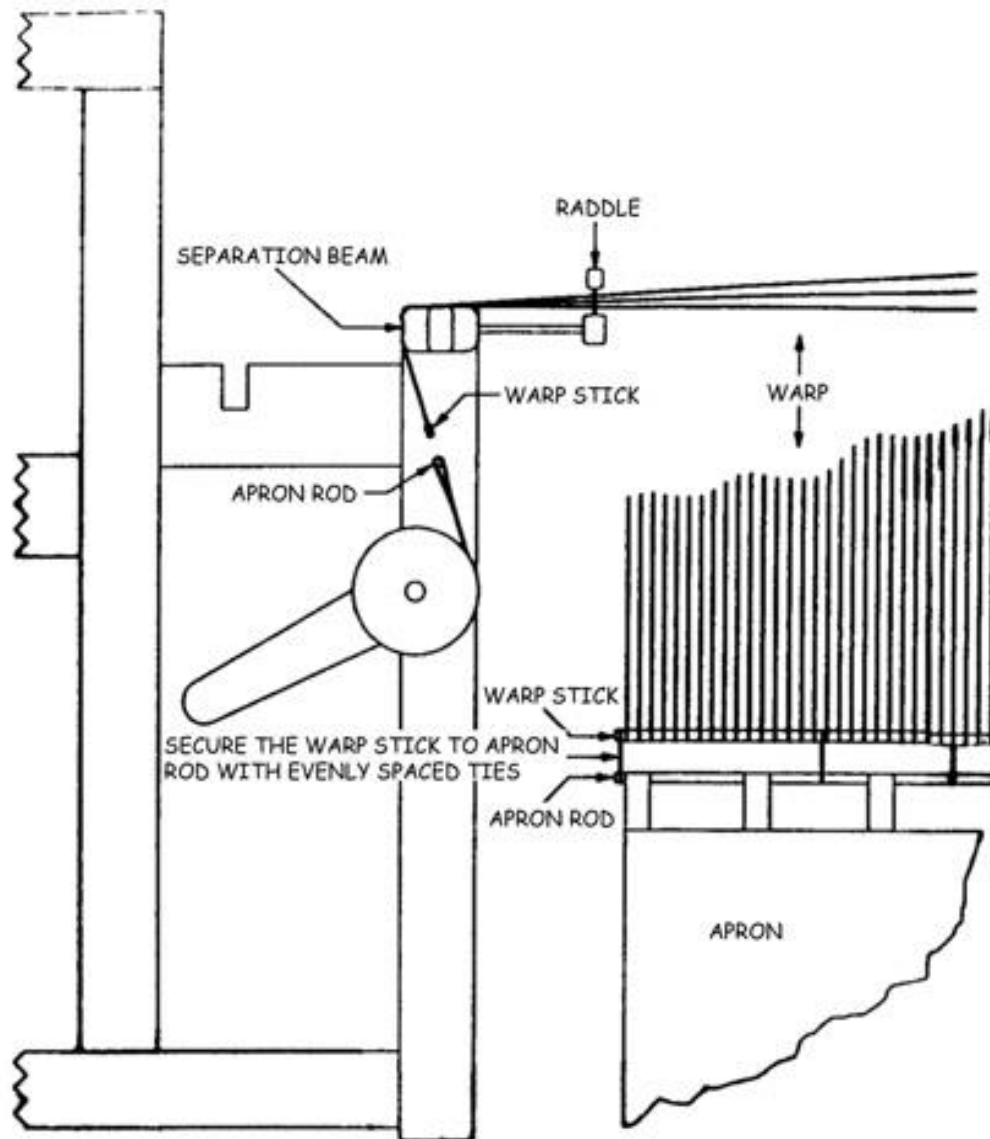
### **Note:**

**The top beam of your loom should be placed with the handle at the left side. The bottom beam of your loom should be placed with the handle at the right side. When winding on from the back of the loom, the top beam should be wound counter clockwise, and the bottom beam should be wound clockwise.**

Put your apron on the beam with velcro and wind your beam counter clockwise, so that your apron is wound on the beam.

## **Attaching the Warp to the Apron**

Bring the apron around the Separation Beam and put the metal rod through the sleeve at the end. You can lash your warp sections onto that rod or you can attach another rod which has been slipped through the loop at the end of the warp with the Raddle Cross.



**Figure 47 - Attaching the Warp to the Apron**

### Inserting Sticks in the Raddle Cross

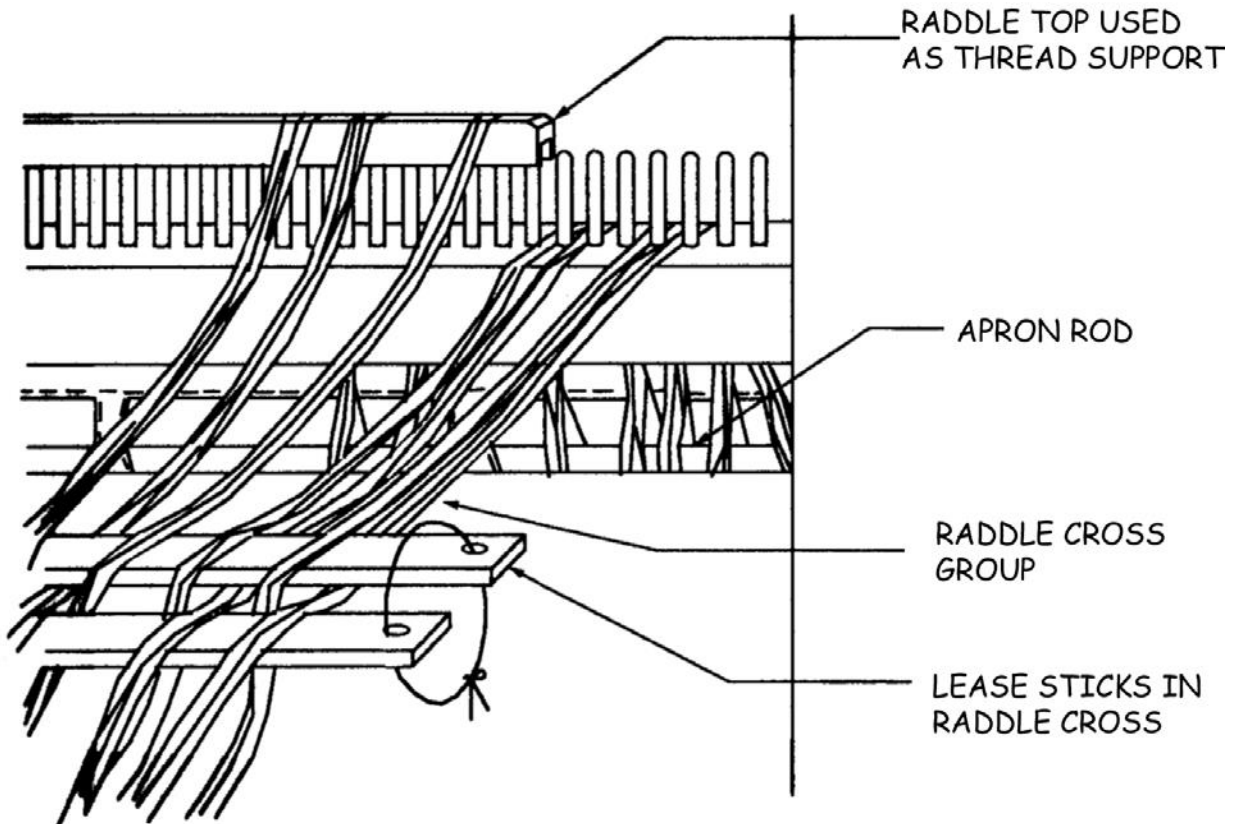
Place two lease sticks in either side of the Raddle Cross and secure together with string through the holes in the ends of the sticks. Now remove the ties from the Raddle Cross and spread the warp out on the sticks.

Measure the center of your Raddle to use it as a center of your warp. The warp threads should either go through the middle of the Raddle or be offset four inches to the right.

## Feeding the Raddle

To feed the Raddle, distribute yarns across the Raddle by dropping each Raddle Cross group into a dent in the Raddle.

If you are using an AVL Raddle with a sliding cover, slide it on after the Raddle is threaded and secure it with two or three cord ties so it can't come off. Remove the Raddle Cross sticks when this is completed.

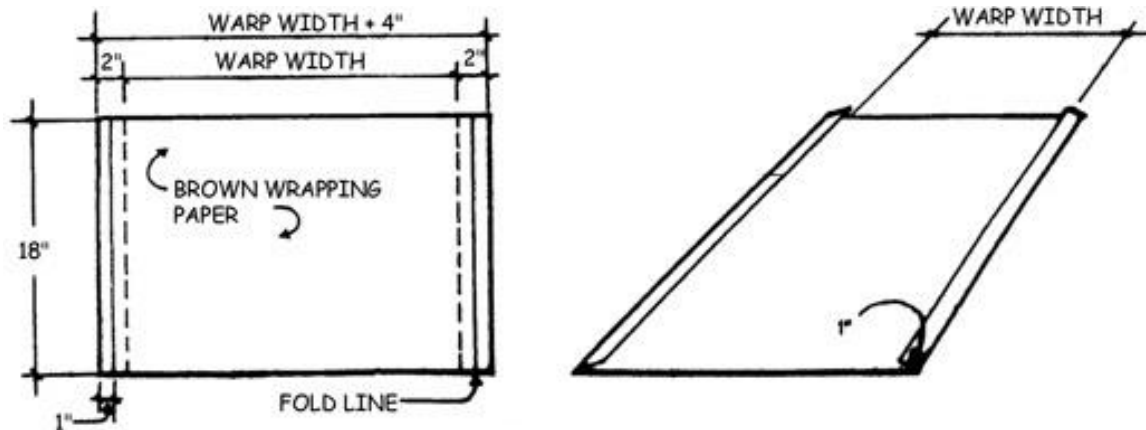


**Figure 48 - The Raddle and the Raddle Cross**

## Preparing the Paper

Prepare the paper for winding between the warp layers. For the most professional results, and fewer tension problems, we suggest that the warp be as smooth, tight, and compact as possible. This would mean not using corrugated paper or sticks as they will make the warp too soft and/or lumpy. Corrugated paper is just too soft and the warp can never be wound tight enough with it. Heavy wrapping paper works well; seventy pound craft paper is good. If you are going to be using smooth, slippery warp yarns like fine linens or perle cottons, the edge yarns are going to need extra help in order not to slip off the sides. To do this, cut your paper four inches wider than the

warp width and then fold over the edges an inch on each side. Be sure the warp is wound between the two folded edges not overlapping them.



**Figure 49 - Prepared Paper with Folded Edge**

### Winding the Warp

Remember; wind the warp on tightly under a lot of tension. The amount of tension used will vary depending on the warp material, but a good rule to remember is that the tension of the wound-on warp must be as great as the tension during the weaving operation. You will need one person to hold a warp under tension on the back and one person to wind the warp on the beam using a handle. The person winding the warp can also insert the paper. For a wide, heavy warp, several helpers may be required.

If you have to do it yourself, you can use the jerking method. Make one turn around with your beam crank and then go to the back of the loom and jerk one narrow section (2-3 inches in width) at a time to make the newly wound warp tight on the beam. The idea of this method is that the warp does not need to be under tension all the time, but the part that is on the beam has to be tight. Make another turn, go to the back of the loom, and jerk all the sections again and so on. If you have a wide warp, you might need to do multiple jerking motions after each turn.

### Threading Cross

When you come to the end of your warp, insert lease sticks at either side of your Threading Cross. Tie the two sticks together at each end.

### Removing the Raddle

When the warping is completed, free the warp from the Raddle. If you have an AVL Raddle, first untie the security strings, lift the Raddle top off, and remove the warp from the Raddle. Afterwards, replace the top on the Raddle

and leave it in its place on the back of the loom as it will not interfere with the weaving process. Then be sure to bring the end of the warp around the Separation Beam so that it now travels into the loom.

Using a strong cord, suspend the lease sticks between the Separation Beam and the Harnesses.

Now remove the ties from each Threading Cross and spread the warp out on the sticks.

## Using Two Beams

There will be times when you will want to use more than one warp, which cannot be put together on one beam.

You will have to put them on separate beams with separate tension systems.

### When Do You Need To Tension Your Warps Separately?

When weaving:

- Very different size yarns.
- Yarns with different stretching qualities.
- Different densities.
- Different structures.
- Supplementary warp techniques (because some warp threads do not interlace as often as others).
- A group of special yarns for selvages and borders. Loops, piles, or puckers like seersucker.
- More than one layer with different setts in each layer.
- More than one layer with a different pick count in each layer.

## Setting Two Beams

The process of setting up a second beam is the same as setting up one beam. You need to be careful not to mix sequences between the beams. It will also take more time to setup two beams rather than one.

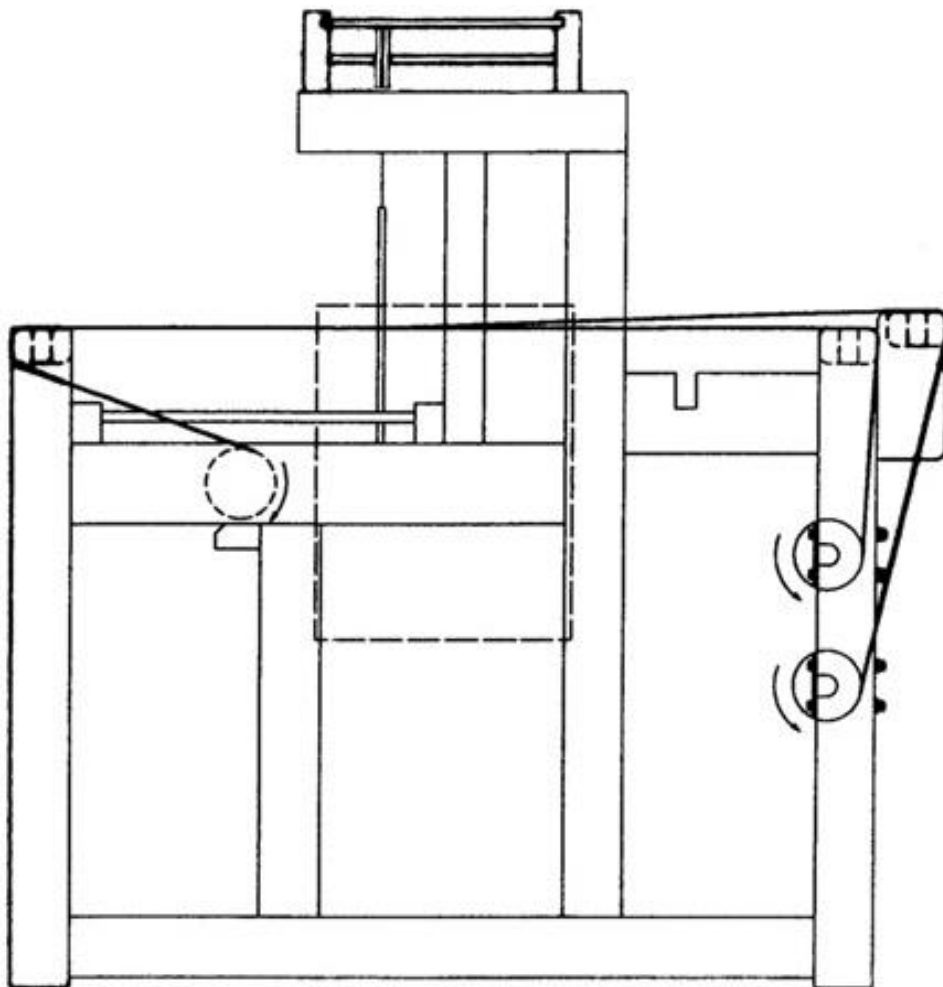
The loom allows you to have two plain beams on the loom. The second beam is placed in the bottom position, with the handle on the right side of the loom. *This means your wind-on direction will now be clockwise.*

Before winding the sectional beam, make sure to disengage the tension system so that the beam will turn counter-clock-wise swiftly. To do this, unlock the tension rope from the spring and completely unwrap the plastic



cord from around the tension beam drum. Also, remember to remove the weight from the tension arm, if you have automatic tension on your loom.

- 1) Wind each warp on the beam the same way you would do it if there were only one beam on the loom (plain or sectional). Make a cross and have a pair of lease sticks with a cross in each warp.
- 2) The warp from the upper warp beam goes over the separation beam on the rear verticals. The warp from the lower warp beam goes over the separation beam on the additional bracket.
- 3) Proceed with a threading as if you were only working with one beam. Follow your threading instructions and take special care which thread from which pair of lease sticks comes next.



**Figure 50 - Warp Routing**

**More Than Two Warps, Only One Beam? Separate Tensioning!**

If you do not currently have two beams, or you need more than two separate warps, you can weight and tension your additional warps separately on the same beam. Follow the instructions below.

- 1) Make your warp sections on the warping board and take them off the board in a chain, on a kite stick, or just in a plastic bag.
- 2) Make sure that each bundle is not too thick. You will know when you need to divide each bundle if you feel that all the threads are not being tensioned evenly.
- 3) The weight needs to have a strong loop of string on it so the warp bundles can be slip knotted into it. This makes it easy to undo the slip-knot and move the weight when it climbs up to the back beam and must be let down again.
- 4) The weight also needs to be adjustable. Plastic bottles, with handles, filled with water are perfect. You can also use fishing weights, washers, nuts, bolts. They are not as easily adjustable as water bottles, but take less space. The closer to the floor you can hang them, the less often you need to reposition them.

**WARPING THE SECTIONAL BEAM**

The AVL Sectional Beam can be warped in sections with the use of a Tension Box. The yarn travels directly from cones or spools, which are mounted on a rack behind the loom, through the Tension Box, and onto the Beam. Throughout the warping process, the Tension Box automatically keeps a constant and uniform tension on the warp. The Tension Box allows you to make longer warps than other methods.

You can also warp a sectional beam using the AVL Warping Wheel. With the AVL Warping Wheel you wind threads onto the wheel then wind them from the wheel directly onto the beam. When using a warping wheel, your warp length will need to be less than 24 yards.

**Extension Cords**

You might want to make a permanent set of Extension Cords to use when warping the Sectional Beam. Extension Cords are also called "apron cords" and serve the same function as the apron on the Plain Beam. They give you "reach" from the Warp Beam and allow you to weave every possible inch until the end of the warp touches the last Harness you are using. Make them

out of a strong non-stretchable linen or cotton cord. You will need to make one Extension Cord for each section in your Sectional Beam. For each Extension Cord:

- 1) Measure a piece of cord long enough to reach from the axle of the Warp Beam, at least one and a half revolutions around the Beam and then reach to the back most Harness.
- 2) When measuring the length of the cords, take into account that, when the warp is attached to the Extension Cord the knot between the cord and the warp needs to fall between the Crosspieces of the Sectional Beam, not on them. This will keep the warp smooth on the Beam so it doesn't go over the knots created when attaching the warp to the cords.
- 3) Now double that length and cut it. All Extension Cords should be exactly the same length, so cut them all at the same time.
- 4) Take the two ends of the cord and knot them together, using an overhand knot.
- 5) Wrap the cord around the center bar of the sectional beam with a larks head knot. You will also use a larks head knot to secure the warp threads to the extension cord.

### **Using a Tension Box**

The Tension Box is an essential tool for Sectional Warping, which:

- Puts threads under even tension.
- Spreads threads to the proper width of the section.
- Makes a thread-by-thread cross.

### **Sectional Beam Calculation**

First, you must calculate the number of spools or cones of yarn you will need. Each section is wound onto the Sectional Beam separately; therefore, you'll need to have one spool or cone for each end in that section. For example, if your section is 2" wide, with sixteen E.P.I., you would need thirty-two spools or cones of yarn.

To prepare for Sectional Beam warping, we need to calculate:

- **NUMBER OF SPOOLS?**

Sectional Beaming requires the use of as many spools loaded with thread per individual section as your Ends Per Inch, or planned sett in the reed, dictates.

To calculate the actual number of spools required, we need to know:

- 1) how many EPI (this is the sett) are you going to use in the warp
- 2) what SIZE of SECTIONS (1" or 2") will you use on the Beam

If your warp is set at 24 epi per 1", you will need 24 spools for a Sectional Beam with 1" sections or 48 spools for a Beam with 2" sections.

**# OF SPOOLS = EPI x SIZE OF THE SECTION**

- **NUMBER OF YARDS PER SPOOL?**

To calculate the number of yards per spool, we need to know:

- 1) the LENGTH OF THE WARP
- 2) NUMBER OF SECTIONS on the Beam

We calculate the number of sections by dividing the WIDTH OF THE WARP by the SIZE OF THE SECTION. If the warp width is 30" and we are using 2" sections, our number of Sections is 15.

**# OF YARDS PER SPOOL = LENGTH OF THE WARP x # OF SECTIONS**

- **TOTAL YARDAGE?**

If it is a single color warp or if a color sequence is repeating in each section, the same spools or cones can be used to wind all the sections needed for the warp.

**TOTAL YARDAGE = # OF SPOOLS x # OF YARDS PER SPOOL**

It is important to make these calculations in advance so that you can purchase your yarn in spools or cones corresponding to the amount of yardage needed on each. Sometimes this is not possible and you will need to wind your own spools from yarn that is in larger packages. For doing this, you will need empty plastic spools, a bobbin winder (preferably electric), and a yardage counter. These items are available from AVL.

### Feeding the Spool Rack

Next, place a Spool or Cone Rack about five or six feet behind your loom. Place the spools or cones for the first warp sections on the Cone Rack.

Make sure you put each thread through the metal eye on the spool rack so the threads do not get tangled.

When arranging the spools on the Spool Rack, it doesn't matter whether you go top to bottom or bottom to top, the important thing is to be consistent in vertical columns and to place the spools in the order that the threads are in the warp.

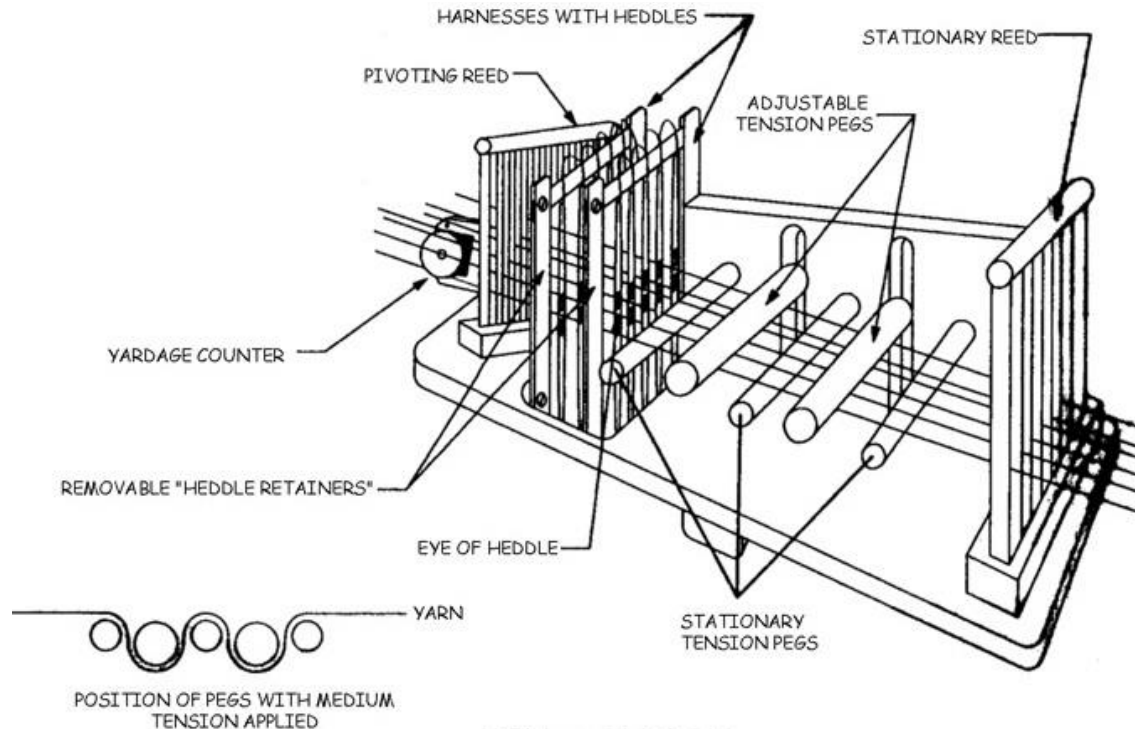
### **Tension Box Heddle Installation Instructions**

The first time you use a Tension Box, you need to install heddles on the harnesses of your Tension Box.

Your Tension Box is delivered with one bundle of one hundred heddles. These are held together with twist ties. Leave these on for now. Refer to the following diagram to familiarize yourself with the Tension Box and its parts. Push down on one of the harnesses until it stops. This causes the other harness to go up. You will use that later for making a Threading Cross. Right now we'll need to use it to help put the heddles on the harnesses.

- 1) Remove the "heddle retainer" of the harness that is up, using a phillips head screwdriver.
- 2) Notice there are four twist ties holding the heddles together. Separate the top two. Insert the top bar (of the harness that is up) into the space created by pulling apart the twist ties. Insert the bottom bar (of the harness that is up) into the space created by pulling apart the bottom two twist ties, making certain that the heddles aren't twisted. Now remove the twist ties.
- 3) Count off fifty heddles and cut the loop at the top between the 50th and the 51st heddle.
- 4) Now put the four twist ties back on the fifty heddles that were the last to go on the harness.
- 5) Remove these fifty and reattach the "heddle retainer".
- 6) Now push down on the harness that is up, making the other harness come up.
- 7) Remove the heddle retainer.
- 8) Pull apart the top two twist ties and insert the top of the harness (which is up) into the space created. Pull apart the bottom two twist ties and insert the bottom of the harness into the space created.

## 9) Reattach the heddle retainer.

**Figure 51 - Tension Box****Positioning the Tension Box**

First bring the Front Beam to the back of the loom and mount it in the two notches located on the Mid-Rear Horizontals (#6, #6A). Next, flip the Separation Beam at the back of the loom, exposing the side with the groove in it. If you have two Warp Beams and have mounted the second Separation Bar, remove it for this process.

Mount the Tension Box in the groove, with the Counter facing into the loom. The Tension Box is fastened to the Separation Beam with a small cross piece and wing nuts. This will stabilize the Tension Box and allow it to travel smoothly from one section to another. The wing nuts can be released for the Tension Box to move easily from side to side. Each time the Tension Box is moved and centered properly for a particular section, the wing nuts must be tightened again.

**Threading the Tension Box**

The best way to thread the Tension Box is to take one thread from the furthest left cone (as you face the Cone Rack, with your back to the loom) and thread it all the way through all the parts of the Tension Box, nearest to the back plate of the Box, then the next thread all the way through. It works

best to use the threads from the rack in a vertical order rather than a horizontal order.

Now let's go through the sequence for threading the Tension Box. First, move the two adjustable Tension Pegs up above the Stationary Pegs or remove them completely. Now, using a sley hook, draw the thread through the Rear (stationary) Reed. Since this reed is eight dents per inch, you will divide the E.P.I. into eight to find out how many ends will be in each dent (with sixteen E.P.I., put two ends in a section). If your E.P.I. does not divide equally by eight, you can either vary the number of ends in each dent (with twenty E.P.I., alternate two and three ends in the dents) or thread the dents a little wider than two inches (with twenty E.P.I., put two ends in each dent; with forty ends, the reed will be sleyed 2-1/2" wide).

Next, bring the thread straight through the Tension Peg section, between the larger adjustable Tension Pegs and the smaller, stationary Pegs or just above the smaller stationary Pegs if you have removed the larger ones.

Thread the first end through one heddle on the Front Harnesses, nearest to the back plate. The next end will go through the first heddle on the rear Harness. Repeat this, alternating harnesses for the rest of the ends. The heddle system will be used later to create the Threading Cross.

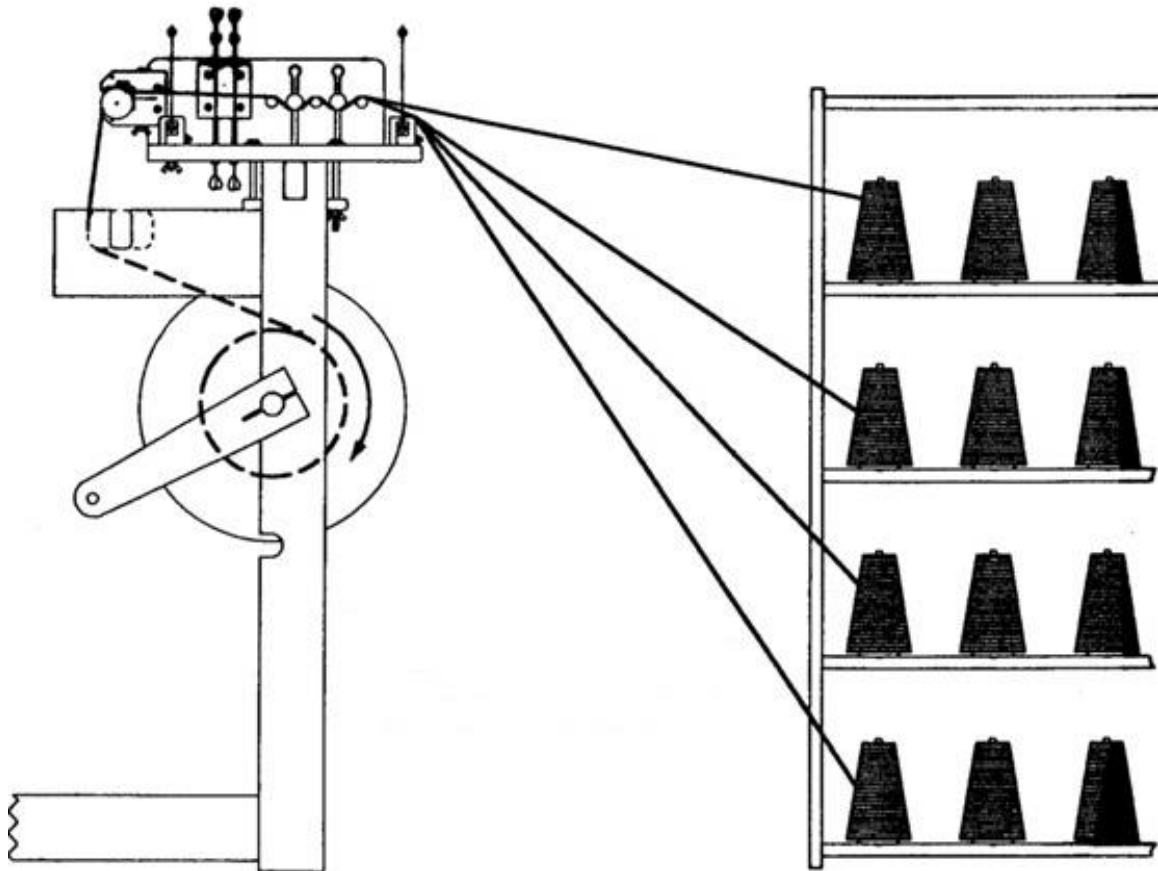
Now thread the end through the front Pivoting Reed. Here you have a choice of using an eight dent or ten dent reed. Pick the one that can be sleyed evenly and as close to the desired section width as possible. If you cannot get the exact width of the section, sley your reed slightly wider. This will make it just slightly wider than the space between the hoops. The section will be narrowed down by pivoting the Reed. Never sley the reed narrower than the section on the Beam because it is critical that the ends wind on evenly across the width of each section. If the ends are set too narrow at the Pivoting Reed, there is no way to expand it.

After the Tension Box is completely threaded, move the larger Pegs downward and tighten their wing nuts securely, to apply tension to the yarns. The further down the Pegs are moved, the more tension will be applied to the yarn. This is an adjustable system as different yarns require more or less tension. With a heavy wool, the Pegs may only need to be moved half-way down, whereas with a fine silk, the Pegs may need to be moved all the way down and the yarn wrapped an extra time around one of the stationary Pegs to get the proper tension. Once you have adjusted the tension correctly, do not change it during the winding of the Beam, as long as you are using the same type of yarn.

Once the Tension Box has been threaded, it is not always necessary to rethread it. If you need to change spools or cones, simply tie the new ends on to the old ends just before the rear stationary reed and pull gently on the old ends until the new ends have come all the way through the box.

### Winding the Warp

In Chapter 3 you installed the Brake/Tension Device. Before winding on the warp. Check the tension device to make sure the rope is wrapped three times around the tension drum and that the rope end is clipped to the spring, which is held by the Hook Bolt. Test that you are able to turn the Beam. If this proves difficult, you can let some length out of the nylon cord by pressing on the toggle button and moving the toggle up and down on the cord. This will allow you to turn the Beam backwards during winding, while stabilizing the Beam when it is at rest. Don't forget to retighten the cord before you begin threading the heddles!



**Figure 52 - Winding on the Warp**

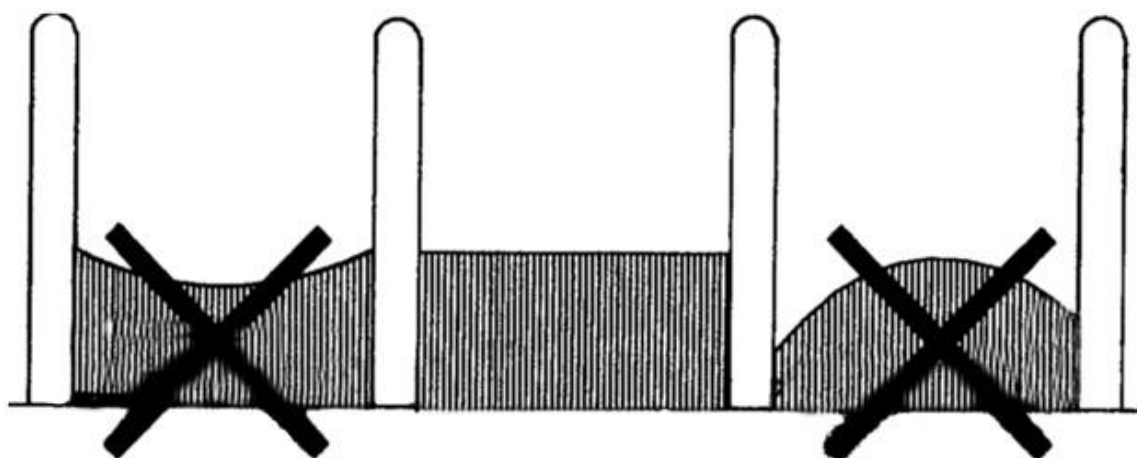
Tie an overhand knot near the end of the warp threads from one section and slip that knot into the opening of the larkshead knot you create in the Extension Cord. Pull it tight.



Line up the Tension Box to the section you will be winding.

### Adjusting the Size of the Section

Now, slowly wind about one revolution onto the Beam. As you wind, you will need to fine-tune the placement of the Tension Box along the track. When it is centered properly, tighten down the wing nuts under the Tension Box. At this point, you can pivot the "pivoting reed section" so that the yarn comes close to, but doesn't quite touch, either the hoop to the left or the hoop to the right. Now tighten the wing nut under the pivoting reed. This shouldn't need to be readjusted unless you are using a different yarn size in another section.



**Figure 53 - Adjusting the Size of the Section**

Extra care to correctly center and adjust the width of each warp section will result in more perfect tension while weaving.

Make sure that the threads are going on to the Beam in flat layers. If you notice that warp piles up at the hoops, the section of the warp is too wide. If the warp falls down at the hoops, the warp section is too narrow.

If any of the above is happening, gently unwind the warp (into a box, perhaps) and pivot the front reed on the Tension Box again until you get perfectly flat layers. This is very **important**, otherwise you will end up having different length threads in one section, since the circumference of the Beam within the section is not going to grow evenly. This uneven tension will cause tension problems.

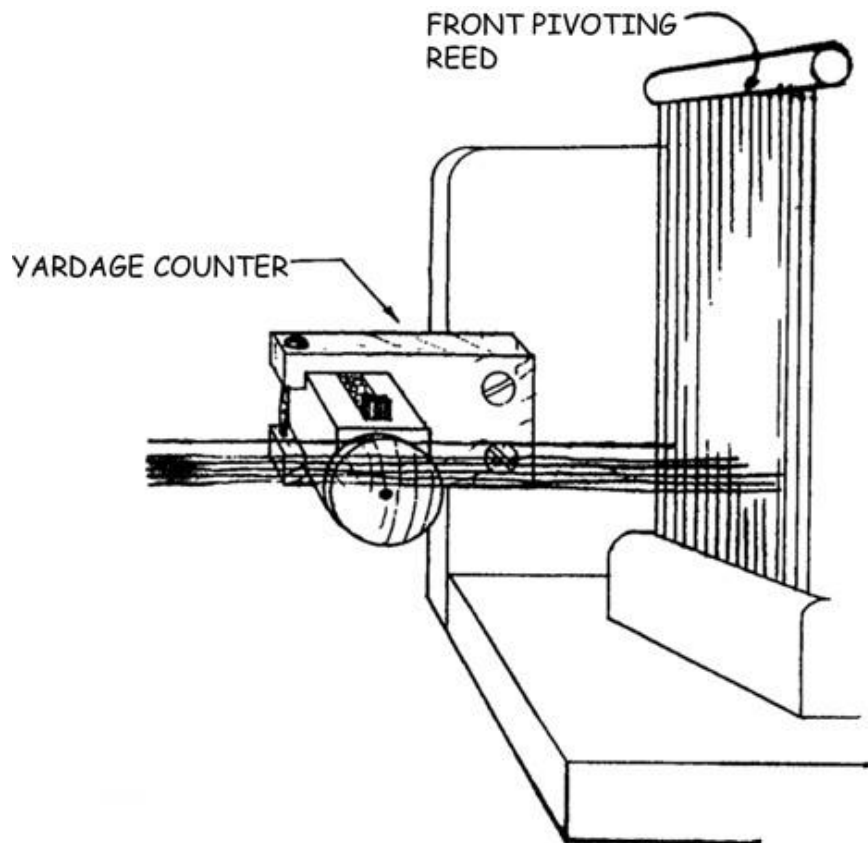
### Counting Turns or Yardage

To determine the length of the warp you are putting on the Beam, you need to count either turns, revolutions, or yards.

To count turns, you can do it in your head, but it is more reliable to use a digital or mechanical revolution counter.

Counting revolutions even with a digital counter will only give the approximate warp length, because the circumference of the Beam will increase slightly with each rotation. This is called "Beam Build Up".

To count yards with a Yardage Counter while warping the Sectional Beam, you need to place the Yardage Counter at the front of the Tension Box. You should use an extra thread for measuring yardage, because if you use one of the threads from your warp section, that particular thread would have a different tension once you start weaving. The extra thread you use for measuring purposes can then be reused for each section.



**Figure 54 - Attaching Yardage Counter to Tension Box**

### Creating the Cross

When there is about a half-yard left to be wound onto the Beam, it is time to make the Threading Cross. Simply push on the rear Heddle Frame of the Tension Box, making half of the threads go up and the other half go down.

Now slip in an 8" piece of contrasting thread through the opening (called a Shed) created between the threads above and the threads below. Position this Marking Thread about halfway between the Tension Box and the Separation Beam (AKA the Breast Beam).

Now push down on the front Heddle Frame, making the other half of the threads go up. You may need to give a gentle tug to the section, behind the Box, to help the threads separate into the new Shed. Now take one end of your Marking Thread and bring it through this Shed. The two ends of the Marking Thread should now be together. Tying them in a bowknot, you have just made the Cross. Continue to wind the first section on, until the Cross is nearly on the Beam. Cut the ends, and secure to the section using a piece of masking tape.

Continue winding all the sections in the same manner by moving the Tension Box along its track.

Remove the Tension Box from its track in the Back Beam and flip the Beam over.

Replace the Separation Beam into its former position atop the front verticals, with the groove facing down, to serve you as the Breast Beam.

### **Inserting Sticks in the Threading Cross**

When all the winding is complete, remove the tape, unwind a few feet of warp from each section, and slip one lease stick through the path created at one side of each Marking Tie. Now slip another lease stick through the path created by the other side of each Marking Tie. Secure the lease sticks together, leaving about two inches between them, using masking tape or string through the end holes of the lease sticks. Now bring the lease sticks, with the warp ends, around the separation beams, so that warp travels towards the center of the loom (harnesses). Remove the breast beam from the position behind the harnesses and place it to its original position on the front of the loom.

### **Readjusting the Tension**

Now tie the lease sticks on the side of the loom so that they are at eye level when you are in your threading position.

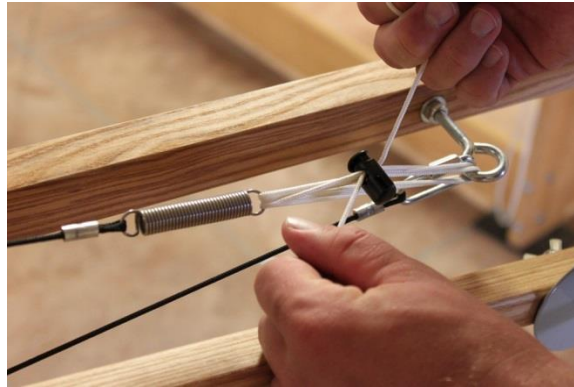
To keep the warp from slipping forward during the threading process, retighten the tension rope around the pulley and tension drum and clip the rope end to the spring.

---

## Use of Warping Wheel

### The Setup

- 1) Adjust height so position of mini-raddle is just below eye level.
- 2) Adjust the wind-off tension with toggle and cord. Tie cord to prevent slipping.

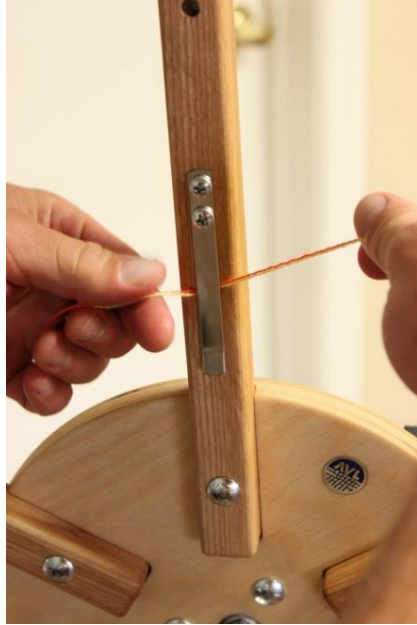


**Figure 55 - Adjust Wind-off Tension**

- 3) Adjust Warp Length using different spool placement by moving the spools on the arms.
- 4) Reset the Revolution Counter to Zero.
- 5) Setup Cones with the Cone Caddy.

### Making the First Section

- 6) Open and secure the raddle top using the removable pin.
- 7) Slide the thread(s) under the metal catch clip, tails facing to the left. Tails should be about 5 inches long.



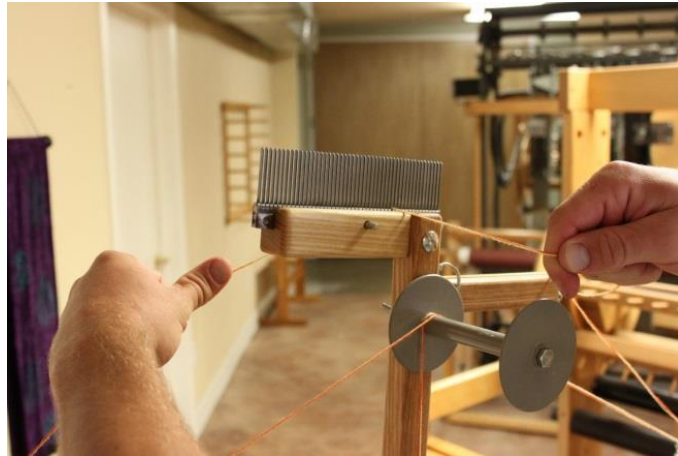
**Figure 56 - Catch Thread Ends**

- 8) Bring the thread(s) up and over the left side of the top spool so that you are ready to wind the Warping Wheel in a counter clockwise motion.



**Figure 57 - Wind Counter Clockwise**

- 9) After you have wound one length bring the thread(s) around the back of the raddle and through a dent (working from right to left).



**Figure 58 - Bring Thread through Raddle**

- 10) Bring thread(s) down over the end you just wound and secure in the silver clip (swooping under from left to right).

#### Tying Off

- 11) Put the raddle top back on. Cut the bout threads just to the left of the clip and under the threads going over the wheel.
- 12) Hold onto the threads securely at the raddle (so they don't slip through). Below, wrap the cut threads around the clip.



**Figure 59 - Hold Threads at Raddle**

- 13) With the raddle top secure, remove the pin from the raddle holder while holding onto the threads.



**Figure 60 - Remove Raddle from Top Position**

- 14) Bring the raddle down to the winding-on position and secure with the pin. Tie a knot in the thread past the raddle so it won't slip through.



**Figure 61 - Place Raddle in Lower Position**

- 15) Take the extension cord from your beam. Create a larks head loop at its end and loop it around the knotted end of your warp section.



**Figure 62 - Place Extension Cord Around Thread Bundle**

- 16) Before the last part of the threads pass through the raddle, tape the threads on the loom-side of the raddle in their sequence using

masking tape. This will help you keep the threads in order when you thread the harness.

- 17) As you wind on, pivot the raddle to adjust the width of the section to fit exactly in-between the pegs on your sectional beam.



**Figure 63 - Pivot Raddle**

## COMBINING SECTIONAL AND PLAIN WARPING

Depending on your equipment and preferences, you may prefer to wind separate warp sections on a warping board or reel and go from there directly to the Sectional Beam. If you decide to do this, however, your warp will be limited in length by what will fit on the warping board or reel. If you choose this method, follow these steps:

- 1) Calculate the number of threads for each section on your Sectional Beam.
- 2) On the Warping Board or reel, make "baby warps" for each section on your Beam.
- 3) Make crosses at each end: raddle cross on one side and thread-by-thread cross on the other.
- 4) Take the warp off the board or reel by taking off the thread-by-thread cross first.
- 5) Put the warp threads from a first "baby" warp in the Raddle, making sure that threads are spread evenly and that they are creating flat layers when wound on the Beam. Put the raddle top on or secure warp threads with rubber bands.



- 6) Instead of a regular raddle, you can put a mini-raddle in place of the front reed on the Tension Box. In this case, the Tension Box is used only for guiding threads into the sections. It is not necessary to sley threads in the Tension Box, either through the harnesses or through the back reed, and you do not need to adjust tension with the Pegs.
- 7) Attach each baby warp to the Extension Cords and proceed as in regular Sectional Beaming procedure.
- 8) Since you are not using the Tension Box for tension, be sure to keep it taut manually.
- 9) When you come close to the end of the section, take the reed cover off and continue winding the rest of the baby warp.
- 10) Secure that section to the Beam and continue to the next one.

If you wish to use the Tension Box to maintain tension on your warp during the Wind-On phase, it will be necessary to make a Cross at both ends of your warp. If you can make your warp slightly longer, you can use the extra length to leave in your Tension Box for the purpose of tying on the subsequent sections.

## **THREADING, SLEYING, & TYING ON**

### **Preparation for Threading**

To prepare for threading, tie the threading cross-sticks in a comfortable and visible position between the Back Beam and the harnesses.

You may also find it helpful to raise the harnesses. To raise all the harnesses, turn on the E-Lift, turn off the double shed action, and pedal once. It is not necessary to turn on the Compu-Dobby at this time.

It is helpful to remove the Breast Beam and the Beater for further comfort and accessibility.

The important thing in threading is your comfort. Take the time to position everything so that your body feels at ease while threading.

### **Threading the Harnesses**

Now we're ready to thread the loom. If you are right handed, it is recommended to start at the right side of the warp. Grasp one group of ends

in your left hand and your sley hook in your right hand. Direct the "hook end" of the sley hook through the "eye" of the first heddle you need to thread. Pull the thread through.

For example, if you had a straight draft on eight harnesses, your first thread would go through the eye of a heddle on the 8th harness. The second thread would be threaded through the eye of the first heddle on the 7th harness, the third thread through the first on the 6th harness, and so on.

Some weavers mark the center heddle on each harness and thread from center, out to each side. This allows for leaving an equal number of heddles at both sides of the harnesses, when threading is completed.

## Unused Heddles

After threading is complete, make sure that the unused heddles are all pushed to the far sides of the harness sticks between the screweyes and the ends of the harness sticks. For balance, there should be approximately equal numbered groups of unused heddles on both sides of each harness. In some cases, such as a very wide warp with a lot of unused heddles on the ends of the harnesses, you may need to tie each group of unused heddles into a tight bundle with tie tapes or string to keep them from falling off the ends of the harness sticks or you may wish to take heddles off the loom altogether.

### Note:

**In the first six months of using a new loom with polyester heddles, the heddles may stretch out slightly to adjust to the harnesses.**

## Sleying the Reed

Now sley the warp ends through the reed. Some weavers start from the right side; some from the left; some in the middle. But, in all cases, be sure to measure accurately before starting so that the warp will be centered in the reed (or offset four inches to the right if the warp on the beam is already offset). Use the way you prefer to position and stabilize the reed between the harnesses and the Breast Beam for ease during the sleying process.

## Tying On To the Apron

Now that you have your warp ends ready to tie, we need to prepare the apron. The ends will be tied to the apron rod.

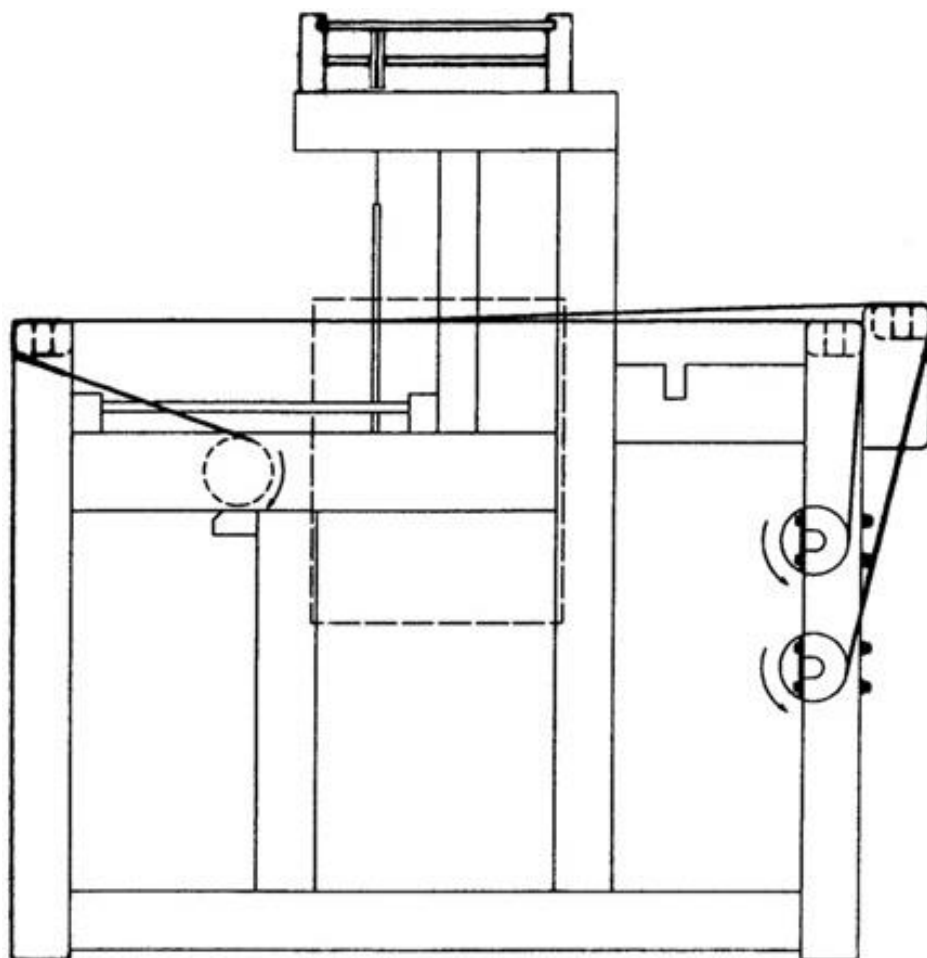
Notice that the apron has two hemmed ends. One end has loops on it and the other end has a velcro strip. The Cloth Storage Beam also has a velcro strip. Measure to find the center of the Beam and, using tape, mark the

center above the velcro strip. Find the center on the apron, at the end with the velcro and fold it in half, with the velcro doubled on itself and facing out. Match center of your fold to the center of the Beam velcro, with the apron length hanging to the floor. Press the velcro strips together firmly, while pulling gently toward each side of the beam, making sure it is centered.

Now you can remove the tape marker and, turning the top of the Beam away from you, wind so the apron is wrapped once around, holding itself in place. Route the apron underneath the Cloth Beam and, towards the harnesses. Spread it out flat and center it over the Cloth Beam and insert the metal rod into the loops at the hem.

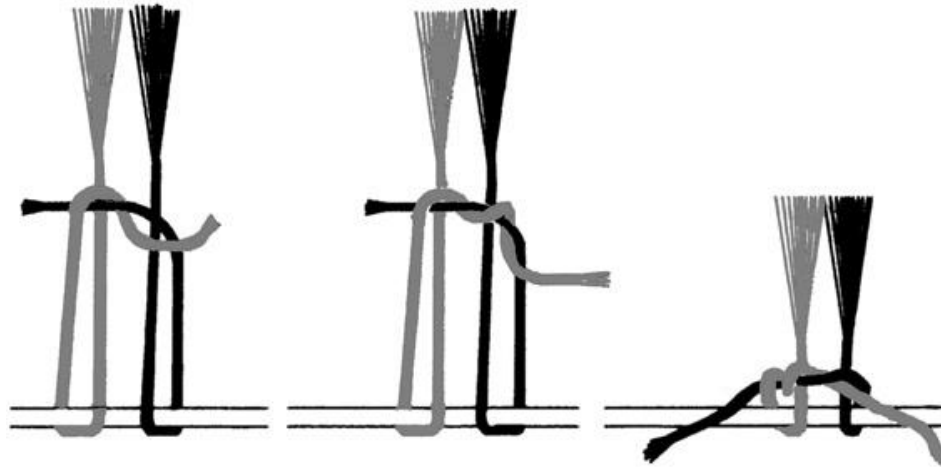
### **Cloth Storage System**

As directed in the preceding warping instructions, you'll secure the front of your warp to the Cloth Storage Beam via its apron. Use the handle at the right of the beam to advance the warp. Simply release warp beam tension by depressing the Brake Pedal(s), push the handle forward into the toothed ratchet, and rotate it down. It will draw the warp forward onto the beam. The pawl is that finger device that engages in the ratchet. Its job is to keep the beam from rolling backwards.



**Figure 64 - Warp Routing**

Now tie the ends to the metal rod. Starting from the middle, bring a first bundle toward you over the apron rod, then around and under it. Divide it in half and bring one half up on each side of the bundle. Use the ends to tie a surgeon's knot. It is the same as the first tie you make tying a shoelace, except you loop the end through twice. This kind of knot is very good for hold and readjusting the tension.



**Figure 65 - Tying on to the Cloth Storage System**

Start with one section in the middle, then the far right and the far left outside ones. Work your way in. After tying the knot, pull only until you feel some resistance and tighten the knot and proceed to the next section.

By now, the sections that were tied first maybe quite a bit looser than the ones tied last. To correct this, you do not need to untie the knots, simply grasp the ends and pull them away from you, then re-tighten the knots, remembering to only pull until you feel, what is now, a uniform resistance at each group. Repeat this until all of the sections are at approximately the same tension. It is important to remember at this point, that you are not tying to achieve weaving tension, only *uniform* tension across the width of your warp. Attaining weaving tension is what the Cloth Beam Ratchet is for!

As directed in the preceding warping instructions, you'll secure the front of your warp to the Cloth Storage Beam via the apron. Use the handle at the right of the Beam to advance the warp and raise the tension. Simply release Warp Beam tension by depressing the Brake Pedal(s) as described above, push the handle forward to engage in the toothed ratchet, and rotate it down. It will wrap the warp onto the beam and draw the fell away from the Beater. The Pawl is that finger device that engages in the ratchet. Its job is to keep the Beam from rolling backwards and it must be engaged to hold the tension.

### Using the Optional Warp Tension Device

To set the warp tension, move the weight to its rearmost position (next to the wooden pulley). Wind the warp forward slowly, using the ratchet handle on the cloth beam. Continue winding until the weighted tension arm rises and stops when the rope slips on the brake drum.

Ideally, the tension arm should rise (as you advance the warp) to about 45 degrees above the horizontal, then slip and rest at an approximately horizontal position. If it stops above the horizontal, let the adjusting cord out at the spring. If it stops below the horizontal, shorten the cord. The length of the adjusting cord is changed by squeezing the ends of the small plastic toggle together and then pulling the cord through it.

Now feel the warp for tension. If the warp is too loose, set the weight further out on the arm. Wind the warp forward a little and check it again. Once you feel you have attached the proper warp tension, make certain that the tension arm is rising and slipping correctly. If it isn't, tighten or loosen the adjusting cord as needed.

### **Tying On To an Old Warp**

A new warp can be tied on to an old warp, thus eliminating the threading and sleying process, if the new warp introduced into the loom uses the same threading pattern and E.P.I. as the last warp. This process is especially good for production weavers as it saves time. It also takes less concentration and there is less chance of making mistakes in threading.

The tying on process starts when you are finishing the last warp on the loom. Before you cut off the fabric from the old warp, make sure to leave enough unwoven warp to extend one foot behind the harnesses, through the heddles, and about six inches past the reed when the beater is in its rear position. Now open two opposite tabby sheds and insert the lease sticks into these sheds behind the harnesses. Secure the sticks together with tie tapes through the holes.

Now carefully cut the fabric from the loom and tie bundles of warp coming through the reed together with a half-knot so the yarn can't slip back through the reed. Cut the warp in back (leaving one foot past the lease sticks) and also use a half-knot to tie bundles of yarn together for security.

After winding on the new warp on the Beam, you can sit behind the loom, on a small stool and tie corresponding yarns from the two sets of lease sticks together. An overhand or weaver's knot work well. This may seem slow at first, but you will work up a faster rhythm with some practice. A good goal to reach would be to tie 200 to 250 ends together an hour.

When all ends are tied together, go to the front of the loom and gently pull on the bundles of yarn going through the reed to pull the new warp through the heddles and reed. You may find that turning small bundles of the warp in a circular, clockwise motion will help them through the heddles and reed. Then tie on to the apron.

# **ADDITIONAL LOOM INFORMATION**

## LOOM MAINTENANCE

### Tightening the Bolts

The single most important thing you can do to extend the life of your loom, and preserve its operation, is tighten the bolts that hold its frame together. These will loosen over time, due to changes in its environment and to your own creative exertions.

### Lubrication and Cleaning

There are several mechanisms on your loom which will benefit from the occasional light application of an appropriate lubricant. Not all lubricants are suitable in the weaving environment. Machine oils and greases, for example, can capture yarn dust and will, over time, actually impede the action of your loom.

<b>Loom Parts</b>	<b>Lubrication and Cleaning</b>
Shuttles, Shuttle Race, Single-Box Flyshuttle Picker Grooves	Paste Wax
Slide Rods (sliding beater rods, bobbin winder)	Steel Wool
Axles (pulleys, spring levers, overhead beater)	Silicon Spray
Warp Beam Metal Rods (where metal works against the wood frame)	Paraffin
Warp Beam Brake Drum	Sandpaper

### Checking Cords and Cables

The cords and cables on your loom will wear out due to the friction of the moving parts. Check all cords and cables for wear and replace as needed.

### Brake System

If you remove the Brake Cable, please be sure, when you reinstall it, that the looped end is secured to the "J" bolt, that the cable is drawn immediately up from this bolt and around the back of the drum (x3), and that it then routes down the front of the drum where it connects to the spring at the pedal. Be sure the cable does not cross over itself at any time.



If you find that the brake cable is not releasing properly, even when you've fully depressed the pedal, you may need to remove the warp beam and lightly sand the groove in the brake drum (use 220# sandpaper or finer). In times of high humidity especially, the grain in the drum may raise and prevent the cable from slipping. Never, under any circumstances, should you apply wax, talc, or other finishes to the groove. The wood here needs to be raw for the mechanism to operate as intended.

If the cable is installed in reverse the beam will not release when you depress the pedal.

### **Swinging Beater**

You can square (or "rack") the swinging beater by loosening the four bolts that attach it to its arms. Bring the beater fully forward and retighten the bolts, while holding it firmly in place. You must have a reed in place on the Swinging Beater to make a good adjustment.

The height of the Beater can be adjusted as well, by turning the three-pointed Knob mounted to the bracket on the Beater Support, to raise or lower the support. You may wish to use a small level to ensure that you have made equal adjustments to both sides of the Beater.

### **Sliding Beater**

If at any point you feel that the beater is not running smoothly on its rods, you can easily adjust it: loosen the large screws in the four mounting blocks; bring the beater forward until it is equidistant from the Front Verticals at each side; retighten the front blocks. Do the same at the rear blocks, using the Castles as your reference point. The beater may require a little persuasion before it comes to square: please don't use a hammer anywhere in the adjusting process!

### **Spring Levers**

The springs of the spring lever return system should also be adjusted for positive harness return, i.e., the harnesses stay all the way down in the depressed position and require the least amount of effort for lifting. This will vary according to the weight of the warp. In general, lightweight, less dense, looser tensioned warps with a smaller weaving width will need very little spring tension to assure positive harness return. Heavier, denser, tighter tensioned, and wider warps will need more spring tension. To tell if the harnesses are returning all the way, open several sheds by working the treadles. Watch the harnesses that aren't lifted and if the tops of their

heddles become loose and tend to move around, then spring tension should be increased, but just enough to get the harnesses to stay down and no more or your treading effort will be made greater than it has to be. Not all harnesses will need the same adjustment. It will depend on the distribution of your warp on particular harnesses.

To adjust the spring tension, simply unhook the spring and then rehook it one chain link shorter (see the assembly section). This tightens the spring and makes it pull down harder on that particular harness. Test the warp again by doing some more treading and if more spring tension is still needed, try one or more chain link less.

Under unusual conditions (perhaps a very tight rug warp) two springs on some or all of the harnesses may be necessary. If all the springs are set the same, the back harnesses will have a looser tension than the front. This is because the back spring levers and their hooks are longer since the back harnesses travel farther when a shed is made. Accordingly, in some cases, the back spring levers might have to be adjusted shorter to give the same tension as the front ones.

## Tool Kit and Spare Parts

Here's a list of the basics, nice-to-have-around items:

- 1) Minimum Tools
  - Socket Wrench with
    - 7/16", 1/2", 9/16" socket
  - 6" or 8" Crescent Wrench
  - Medium Standard Blade Screwdriver
  - 4-1 Screwdriver or Medium Phillips and Standard Screwdrivers
  - 1/8" Allen Wrench
  - Level
  - Paste Wax
  - 0000 Steel Wool Pad
  - 220# Sandpaper
  - Paraffin Wax
- 2) Spare Parts You Might Consider Having
  - Spare Treadle Cable (left/right)
  - 6' length of 350# Braided Dacron
  - Cord (for emergency repairs)

## TROUBLESHOOTING

### Brake Cable

If you find that the Brake Cable is not releasing properly, even when you've fully depressed the pedal, try releasing a little of the nylon cord from the toggle, in short increments. If this is unsuccessful, you may need to remove the Warp Beam Tension Cord and lightly sand the groove in the brake drum

(use 220# sandpaper or finer). In times of high humidity especially, the grain at polar sides of the drum may raise and prevent the cable from slipping.

**Note:**

**Never, under any circumstances, should you apply wax, talc, or other finishes to the groove. The wood here needs to be raw for the mechanism to operate as intended.**

## Harness Float

On occasion you will find that one or more of your harnesses will misbehave. That is more likely to happen with harnesses with Polyester Heddles. There are a finite number of things that can cause these problems.

<b>Symptom</b>	<b>Possible Cause</b>	<b>How to Fix it</b>
A.) One or more top harness stick collapses; it assumes a diagonal angle and one leg of the harness cable from which it is suspended goes slack.	1.) Your heddles are bunched together towards the center of the harness or on one side only. This is a problem because the heddles are part of the harness structure.	Move a few heddles to each end of your harness sticks; just to the inside of the harness wires that connect the top and bottom sticks. That way your harnesses will be balanced.

<b>Symptom</b>	<b>Possible Cause</b>	<b>How to Fix it</b>
	2.) The harness cable supporting the shaft has come out of its pulleys at the top of the loom.	Trace the cable back through its pulleys in the Harness Pulley Support and make sure that the cable is properly seated. Check the action of the Dobby Cable as well. Make sure that it moves easily up and down. If the Dobby Cable seems to bind, check for debris in the hole where it comes through the Dobby Top. You may need to use a very thin piece of wire to dislodge accumulated yarn dust or other debris.
B.) The heddles float; they are lifted upwards by the warp thread when you tension the warp and your shed is not even or not large enough.	1.) The tension in your warp is greater than the tension in the springs that hold the harnesses down.	Take up a link or two in the chain that spans the Harness Spring Levers for that particular harness. Check the result and take-up more links if you feel you need more hold-down tension. Do not try to make all chains the same size. The size will depend on how much tension is required for each harness depending again on the number of threads going through that harness.
C.) One or more harnesses that are supposed to raise don't.	1.) Left treadle isn't being pressed all the way down.	Concentrate on getting both treadles all the way through their travel.

<b>Symptom</b>	<b>Possible Cause</b>	<b>How to Fix it</b>
	2.) Dobby arm out of adjustment.	Realign the doobby arm according to the assembly instructions.
	3.) Dobby cables out of finger slots.	Rearrange the cables according to the assembly instructions.
D.) Harnesses don't raise properly.	1.) Harness cables have been hooked to the wrong harness.	Rearrange the cables.
	2.) Chains from the spring levers have been hooked to the wrong harnesses.	Rearrange the springs.
	3.) Copper hooks on the spring levers have been bent.	Straighten the hooks with pliers.
E.) Harnesses jam up on each other.	1.) Heddles are not distributed evenly over the harness sticks.	Redistribute the heddles evenly on both sides from the center of the harness sticks.
	2.) Harness wire that connects the harness sticks has jumped out and got stuck in the heddles of the other harness.	<p>Pull the wire out, make sure it does not catch any heddles, and replace it to just connect the top and the bottom harness sticks.</p> <p>If you have a large number of extra heddles on each side, you might want to tie them in bundles to prevent getting caught by the harness wires.</p>

# THE FINE PRINT

## AVL CUSTOMER SERVICE

AVL offers free technical support to the original owner of all our looms. This means if you ever have a problem, you can call, fax, or e-mail us and we'll help you find a solution. Please take advantage of this service; your satisfaction is extremely important to us.

**Customer Service Phone: (530 893-4915)**

**Fax: (530) 893-1372**

**E-Mail: [sales@avlusa.com](mailto:sales@avlusa.com)**

## AVL WARRANTIES

Your loom carries a full warranty on parts and labor for two years from the date we ship it to you. Your Compu-Dobby is fully warranted for two years. If a part wears or breaks during this period, we will replace or repair it at our discretion, but at no charge to you.

### AVL Returns Policy

All goods, excepting software, may be returned for refund within thirty (30) days of the shipping date.

A 15% restocking fee will be assessed for all but defective items.

AVL will pay all shipping costs for defective items within the continental United States for the entire warranty period. Special provisions apply for the return of looms (please contact your sales person for more information).

AVL will generally return repair or replacement items via UPS Ground service. Additional charges for expedited shipping are the responsibility of the customer.



## NOTICE TO USERS IN THE EUROPEAN UNION

Products bearing the CE mark are in conformity with the protection requirements of EC Council directives 2004/108/EC, 2006/95/EC, 1999/5/EC, and 2009/125/EC on the approximation and harmonization of the laws of the Member States relating to electromagnetic compatibility, safety of electrical equipment designed for use within certain voltage limits, radio equipment and telecommunications terminal equipment and on the ecodesign of energy-related products.

Compliance is indicated by the CE marking.



The manufacturer of this product is: AVL Looms, Inc., 2360 Park Avenue, Chico, CA 95928 USA. A declaration of conformity to the requirements of the Directives is available upon request from the Authorized Representative. This product satisfies the Class B limits of EN 55022 and safety requirements of EN 60950.



## CERTIFICATE & DECLARATION OF CONFORMITY FOR CE MARKING

### Company contact details:

AVL Looms, Inc., 2360 Park Avenue, Chico, CA 95928, USA  
Tel: 530-893-4915 Fax: 530-893-1372

**AVL Looms, Inc. declares under their sole responsibility that their:**  
Textile Producing Looms listed as follows

### A-Series Looms with the following part numbers:

A30-8H-CD4, A30-16H-CD4, A30-24H-CD4, A30-32H-CD4-E, A30-40H-CD4-E, A40-8H-CD4, A40-16H-CD4,  
A40-24H-CD4, A40-32H-CD4-E, A40-40H-CD4-E, A48-8H-CD4, A48-16H-CD4, A48-24H-CD4,  
A48-32H-CD4-E, A48-40H-CD4-E, A60-8H-CD4, A60-16H-CD4, A60-24H-CD4, A60-32H-CD4-E,  
A60-40H-CD4-E, A72-8H-CD4, A72-16H-CD4, A72-24H-CD4, A72-32H-CD4-E, A72-40H-CD4-E

### V-Series Looms with the following part numbers:

V30-16H-CD4-E, V30-24H-CD4-E, V30-32H-CD4-E, V30-40H-CD4-E, V40-16H-CD4-E,  
V40-24H-CD4-E, V40-32H-CD4-E, V40-40H-CD4-E

### SDL looms with the following part numbers

2010, 2030, 2010-30, 2030-30

(where the 2010 is a 20" weaving width with 16 frames, the 2030 is a 20" weaving width with 24 frames,  
the 2010-30 is a 30" width with 16 frames and the 2030-30 is a 30" width with 24 frames)

### Workshop Dobby Looms with the following part numbers:

3010, 3020, 3030, 3040, 3050, 3060 (where the 3010 is a 16" weaving width with 8 frames, 3020 is 16" with 16 frames,  
3030 16" with 24 frames, 3040 is 24" with 8 frames, 3050 is 24" with 16 frames and 3060 is 24" with 24 frames)

### comply with the Essential Requirements of the following EU Directives:

Machinery Directive 2006/42/EC Low Voltage Directive 2014/35/EU EMC Directive 2014/30/EU  
Radio Equipment Directive 2014/53/EU RoHS 2 Directive 2011/65/EU

### and further conform with the following EU Harmonized Standards as applicable:

EN ISO 11111-1:2016 EN ISO 4414:2010 EN 60204-1:2006 + A1:2009  
EN 61000-6-3:2007+A1:2011 EN 61000-6-1:2007 EN 300 328 V2.1.1

**Dated:** 16 June 2017 **Position of signatory:** President **Name of Signatory:** Theodore Kruger

### Signed below:

on behalf of AVL Looms, Inc.