

K-Series Loom User Manual



AVL Looms
2360 Park Avenue
Chico, CA 95928-6785
U.S.A.

530 893-4915
530 893-1372 fax
sales@avlusa.com
www.avlusa.com

Version 2.2
January 29, 2020
Corrected 10/06/2020

Introductory Information	1
Safety	2
Introduction.....	4
Loom Features	4
Compu-Dobby V on the K-Series Loom.....	9
Set Up	10
Loom Assembly	13
Before You Begin	14
K-Series Crossmember Hardware.....	14
Identifying Pieces.....	15
Inserting Nuts And Bolts	17
Unpacking the Loom.....	18
Unpack the Side Frames	18
Install the Rear Cross Member	19
Install Lower Harness Pulley Support.....	22
Install the Front Treadle pulley support with axle	24
Installation of Lower front assembly	25
Install The Upper Harness Pulley Support	27
Attach the Lower treadle cable pulley guide	29
Squaring The Completed Frame	30
Install Harness Assemblies	31
Add Heddles to the harnesses	36
Attach the Treadle Cables.....	37
Place the Power Box on the Loom.....	42
Install The Cloth Storage Beam.....	43
Install The Swinging Beater Assembly	45
To Remove or to Change the Reed	48
Install the Cloth Guide Rollers	54
Install the Cloth Beam.....	57
Install The Upper (Primary) Warp Beam	60
Install The Lower (Secondary) Warp Beam.....	65
Install The Shelf	69
Connecting The Compu-Dobby	69



Additional Loom Options.....	73
Rotary Ring Temples.....	74
Track & Mount	77
Raddle.....	79
Casters	80
Weaving Instructions	83
Loom Orientation.....	84
Warping the Loom	84
Warping Direction.....	85
Warping The Plain Beam	88
Warping The Sectional Beam.....	94
Combining Sectional And Plain Warping	108
Threading, Sleying, & Tying On	109
Setting The Tension	113
To Remove or to Change the Reed	114
Using the Beater.....	119
Using the Automatic Cloth Advance	120
Using the Cloth Storage Roller.....	120
Using the Ring Temples	121
Removing the Cloth from the Loom.....	122
Additional Loom Information.....	123
Loom Maintenance.....	124
Troubleshooting	134
Reference Guide.....	138
The Fine Print	139
AVL Customer Service	140

INTRODUCTORY INFORMATION

SAFETY

Before Getting Started:

Please read the entire manual before using the loom.

Warnings:

WARNING:

EQUIPMENT SHOULD ONLY BE USED FOR TEXTILE MANUFACTURING. IF THE EQUIPMENT IS USED IN A MANNER NOT SPECIFIED BY THE MANUFACTURER, THE PROTECTION PROVIDED BY THE EQUIPMENT MAY BE IMPAIRED.



WARNING:

ELECTRICAL SHOCK HAZARD. DO NOT TAMPER WITH ELECTRICAL WIRES OR OPERATE THE LOOM WITH SAFETY PANELS OPENED OR REMOVED.



WARNING:

PINCH, CRUSH, AND FINGER CUT-OFF HAZARDS. DO NOT OPERATE THE

LOOM WITH SAFETY PANELS OPENED OR REMOVED. DO NOT PLACE HANDS IN MOVING MECHANISMS.



WARNING:

EQUIPMENT IS HEAVY. TO AVOID MUSCLE STRAIN OR INJURY, USE PROPER LIFTING TECHNIQUES AND A HELPER.

WARNING:

DO NOT POSITION EQUIPMENT IN A WAY TO BLOCK OR IMPEDE ACCESS TO DISCONNECTING DEVICES

WARNING:

USE OF CONDUCTIVE FIBER OR YARN ON OR AROUND THIS EQUIPMENT WILL VOID WARRANTY AND MAY DAMAGE EQUIPMENT.

Safety Features:

Covers and shielding separate weaver from moving components where pinch hazards exist and high voltage circuitry. Do not remove covers and shielding while the loom is operating.

INTRODUCTION

About AVL

AVL Looms has been in the business of designing and building some of the world's finest handweaving looms since 1977.

Jim Ahrens had been building and designing looms for a number of years before Jon Violette, the "V" in AVL, approached Ahrens about a partnership in 1977. Violette, an industrial management professional, had discovered Ahrens' work through his sister who ran the Pacific Basin School of Textiles in Berkeley, where Ahrens was a volunteer advisor.

The two men worked together in the Bay Area for three years until Violette moved Ahrens and Violette Looms to Chico, where it officially became known as AVL Looms Inc., and has operated ever since.

In 1982, Violette was instrumental in the development of the first computerized dobby, then called the "Apple Dobby". He retired from active life in the company in 1987.

Once known for our production looms, AVL has broadened its line considerably and we now offer customers a full spectrum of fine weaving equipment, ranging from our small Home Looms, to our Industrial Dobby Looms, Rug Looms, and Jacquards.

The K-Series Loom Design Concept

The guiding concept behind the K-Series Loom is ease of use. The loom is designed to be easy to thread, easy to setup and easy to weave on.

LOOM FEATURES

Countermarche Loom with Compu-Dobby[®]

The K-Series dobby offers the best of all worlds with these features:

- The countermarche design has a large shed and works well with all types of weave structures. The center shed eliminates the need to adjust for harness float, which is seen with rising shed and jack style dobby looms.

- Counterbalanced harnesses use dobbie weights in a closed loop setup to ensure light and balanced treadling no matter which pattern is being used or how many harnesses are being lifted. Lifting either one or forty harnesses requires minimal effort and feels nearly the same.
- Available with 8, 16, 24, 32 or 40 harnesses, this best in class capability provides flexibility and freedom for the ultimate weaving loom.

Fitted to the countermarche loom is the Compu-Dobby 5. A first for handweaving looms, the Compu-Dobby 5 enables computer control of pattern *and* key loom functions, including warp tension and pick spacing.

Pattern control is a state of the art system that eliminates the multi-treadle dance of traditional looms and the tedious pegging of mechanical dobbie looms. Much like the legacy cartridge systems from the Compu-Dobby I and II, the Compu-Dobby 5 stores entire weaving files (WIFs) onboard with three significant advantages over all other systems:

- Ultra-fast pick writing. The system can achieve weaving speeds in excess of 100 picks per minute.
- Hundreds of weaving files may be stored for later use.
- Eliminates latency timing issues inherent in computer communications systems. Latencies can cause slower weaving and even missed picks.

As a web enabled device, this loom connects to your computer or tablet via WiFi or USB and controls the loom from your favorite browser. AVLDrive version 5 is an easy to use, intuitive interface run from within the Compu-Dobby 5. As a result, there is no software to install for the loom, nor is there any limitation on the controlling device, except for a minimum screen resolution (1024 x 768 pixels). AVLDrive is compatible with all major browsers, including Safari, Chrome, Edge, Firefox and Opera.

Warp Beams and Automatic Warp Tension System

The K-Series comes equipped with a ½-yard sectional beam. The sectional warp beam includes a handle and enough hoops to make 2" (5.1 cm) sections. The hoops are moveable allowing sections of any width, provided they are calculated in 1" (2.6 cm) increments. Removing all the hoops turns the sectional beam into a plain beam.

Additional hoops can be ordered to make 1" (2.6 cm) sections.

A regular plain warp beam with apron and 2 rods may be substituted for the sectional beam at no extra charge.

A second or supplemental warp beam can be added to the loom. It can also be either a ½-yard sectional or plain beam.

The K-Series takes our unique, live weight-style automatic tensioning systems up a notch by providing digital controls. Traditional looms use a locking brake which slows weaving considerably and adversely affects the quality of the fabric. An automatic tension system has three significant benefits:

- Maintains warp tension at all times.
- Allows advancing of the warp without taking off tension, thus removing inconsistency in fabric density.
- Provides a small amount of tension release during the beat to reduce the sharp impact on the fabric and reduce the chance of end breakage.

Another first in our industry, the K-Series' digital control of warp tension uses a small electrical motor and drive system connected via spring and brake cable to the warp beam. The motor is controlled by the Compu-Dobby & AVLDrive. Easily change the warp tension at any time during weaving with a click of the mouse or a touch of the finger on the touchscreen. This system allows very fine, repeatable control with a range from locked beam to free turning for winding on the warp.

Cloth Beam with Automatic Cloth Advance

The K-Series comes standard with AVL's signature sandpaper covered cloth beam and automatic cloth advance. A cloth beam cover protects delicate skin and clothes from the abrasive surface. The cloth beam and cover are easily removable for getting in close during loom threading.

Automatic cloth advance is an AVL-only feature on hand weaving looms. Earlier mechanical versions of these systems are well known for providing fine control over pick advance spacing. This feature utilizes digital controls via an electric motor driven worm and gear attached directly to the cloth beam. Similar to the digital warp tension controls, set the picks per inch in AVLDrive and start weaving. Easily change the advance setting or manually advance the cloth at any time during weaving with a click of the mouse or a

touch of the finger on the touchscreen. This system allows very fine, repeatable control. It allows for hundreds of picks per inch or the large movements needed when starting a new warp.

Note:

The default for the system is picks per inch, however, it can be changed to picks per centimeter.

Cloth Storage System with Automatic Cloth Take Up

The Cloth Storage System consists of the cloth storage beam, apron, apron rod and advance system. The beam quickly lifts out for getting in close during loom threading.

Another AVL-only feature, automatic cloth take up is a time saver and cloth preserving feature. The cloth take up system uses a linkage attached to the beater to drive a one-way clutch bearing. The system will automatically take up any slack in your weaving without over tensioning the woven cloth. The system is easily adjustable with the turn of a knob hidden inside the cloth storage beam hub.

Bottom Swing Beater

A bottom swing beater is standard and comes with a stainless steel reed of your choice ranging in spacing of 8-15 dents per inch. Changing the reed can be done quickly by loosening the bolts holding the premium hardwood beater top.

The automatic cloth take up linkage is easily detached via tri-knob thumbscrew and the beater lifts right out of the frame for getting in close during loom threading.

Weights can be added to the beater to make it easier to beat in weft at high densities.

Harnesses

The loom uses a standard rigid harness structure featuring an enclosed, four sided wood harness with stainless steel heddle bars. The heddle bar support system uses a novel flip up bracket to allow for easy unloading and loading of heddles or complete removal of the heddle bar.

The loom comes standard with polyester heddles, or metal heddles are available as an upgrade. Some weavers like metal heddles because they feel these are easier to thread; others prefer quieter polyester heddles.

Loom Frame

The K-Series comes available in 24, 32 or 40" (61, 81, or 102 cm) weaving widths.

Advanced frame construction uses high quality joinery to improve rigidity and strength.

Oiled hardwood construction is good both for longevity, beauty and the environment.

Options

The K-Series has a limited number of options available based on your warping and weaving preferences. These include:

Second or Supplementary Warp Beam Systems

As discussed above, you can use a second warp beam.

Rotary Ring Temples

Rotary Ring Temples are an upgrade available for this loom. Temples are used to maintain good selvages and prevent draw-in. Add in the rotary ring-type system to make the temples automatic with no need to stop and reset as with standard temples. The K-Series rotary ring temples come with a cover to prevent contact with delicate skin or clothing. The K-Series comes with hidden, built-brackets making ring temple installation quick and simple.

Track & Mount

The track and mount system mounts directly to the rear vertical side frame members to provide a stable platform for a tension box.

Raddle

Raddles are commonly used for loading plain warp beams when warping back to front, as it provides the same functions of warp end spacing, smoothing and tensioning as the reed provides in front to back warping. The raddle is AVL's standard 2 piece with a lift off top to make loading of the warp easy. The raddle mounts directly to the rear vertical side frame members.

Casters

Casters can be attached to the K-series loom to make moving it easy. The casters are sturdy and designed to support the weight of the loom. When not in use, the casters lock into place.

Bench

An AVL short bench is the suitable seat for this loom. The short bench provides adjustable height, pivoting seat for ideal angle and a firm, wide base to ensure stability.

Shuttles

Choose from either the standard or short hand shuttle with end feed tensioners. These shuttles provide optimal tensioning to achieve excellent selvage with minimal effort.

COMPU-DOBBY V ON THE K-SERIES LOOM

For the Compu-Dobby V, power should not be removed from the loom without going through the shut-off procedure. AVL recommends that you use an Uninterrupted Power Supply, or UPS, with the Compu-Dobby V.

What is a UPS?

A UPS has an internal battery that charges from your electrical outlet and can provide power to the item plugged into it during power outages. They also provide surge protection. Keep in mind that the battery will not provide power forever. The amount of time the battery will keep your item running depends on how much power the item uses and the size of the battery. The number of items plugged into the battery backup will also affect runtime.



Power requirements for the Compu-Dobby V

The Compu-Dobby V has a power supply of 400 Watts (W). You will need a UPS with a minimum Volt Amps (VA) of 640. Check both the Wattage and the Volt Amps that the manufacturer states for the model. These should both be equal or greater to the amount required by the Compu-Dobby V.

Choosing a UPS

Depending on the model you buy, some of the outlets on the UPS may not provide battery backup. The options available on different brands and models vary widely, so look at various models. You will want to make sure that the UPS will provide enough power for you to successfully shut-down the loom during a power outage. It may be a good idea to test how the UPS works so that you understand what will happen when the power goes out.

Links to more information

Here are some links we found helpful about the UPS:

<https://www.cyberpowersystems.com/blog/how-does-a-ups-work/>

<https://www.howtogeek.com/161479/how-to-select-a-battery-backup-for-your-computer/>

<https://thewirecutter.com/reviews/best-uninterruptible-power-supply-ups/>

<https://www.lifewire.com/best-uninterrupted-power-supplies-4142625>

SET UP

Looms may be shipped fully assembled or knocked-down. Fully assembled looms will arrive crated. Please verify that all entries, halls and doorways are large enough to pass thru with the crate. If knocked down, your loom will arrive in several boxes of various sizes.

Shipping Damage or Missing Boxes

Looms are rarely damaged in shipping. AVL takes special effort in providing suitable packaging, however, on occasion a box will get damaged or go missing. To protect against this, AVL ships every loom insured. We will assist you in the event that there is a problem. We just require you follow these simple steps:

- 1) At receipt of the shipment while the driver is unloading, please confirm receipt of the correct number of boxes as indicated on your copy of the Bill of Lading, and that there is no external damage to the boxes/crate. If any boxes are missing or damaged, please require the driver to make notes on his paperwork. Failure to have the driver note the problem significantly shortens the timeframe for a claim to as little as 5 working days.
- 2) Upon departure of the truck, take pictures of the damaged box and email the pictures to AVL. We will use the pictures to initiate a claim.
- 3) As soon as possible and preferably within a few days, open each damaged box/crate to search for damaged or missing items. We can provide you with a list of what was in the box. Please take pictures of what you see, especially of damage to parts. This information will help us identify what to replace and how much to claim against the insurance.
- 4) Lastly, save your packaging materials and parts in case the freight/insurance company wishes to inspect the damage.

Assuming you have followed above procedure, AVL will replace the damaged parts as quickly as possible. An invoice will be issued with expectation for payment via the claim reimbursement. Should the reimbursement be paid directly to you, the invoice will become immediately due and payable by you.

LOOM ASSEMBLY

BEFORE YOU BEGIN

Putting together your new loom may look intimidating at first, but this manual is designed to guide you through the process with clear steps, pictures, and diagrams. If the manual is unclear or confusing at any point, call us at 530-893-4915. We're here to help.

There is a definite advantage in assembling your own loom. You'll come to know it very well, sooner than you otherwise would, and the better you know your loom, the better you'll be able to use and maintain it.

Tools

First, you'll need tools:

1. Hammer
2. Socket Wrench with 1/2", and 7/16" sockets
3. 1/2", and 7/16" Box Wrenches
4. Large standard screwdriver
5. Small (jewelry sized) standard screwdriver
6. Phillips screwdriver
7. Scissors
8. Crescent Wrench
9. Level (a small one will do)
10. Tape Measure
11. Mallet

You will also need a helper at some points.

K-SERIES CROSSMEMBER HARDWARE



This list of hardware is included in your hardware packet and is applicable to the 24", 32", and 40" K-series loom.

Order of operations	Count	Name	Parts
1	x4	Rear Crossmember	1/4x2-3/4 Hex Bolt w/washer and square nut
2	x4	Lower Harness Pulley Support	1/4x4 Hex Bolt w/washer
3	x4	Front Treadle pulley support w/axle	1/4x2-1/2 FHMS w/square nut

Order of operations	Count	Name	Parts
4	x4	Lower front assembly	1/4x2-3/4 Hex Bolt w/washer & square nut
5	x4	Upper Harness Pulley Support	1/4x2-3/4 Hex Bolt w/washer
6	x2	Lower treadle cable pulley guide	1/4x4 FHMS

IDENTIFYING PIECES

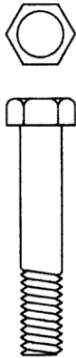
There are a number of different types of hardware that will hold your loom together. The following chart will help you familiarize yourself with the types of hardware you will encounter.

 <p>Figure 1 - Hex Bolt</p> <p>These always get a washer between the head of the bolt and the wood.</p>	 <p>Figure 2 - Flat Head Machine Screw (FHMS)</p>
--	--

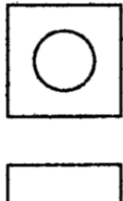
 <p>Figure 3 - Flat Washer</p>	 <p>Figure 4 - Square Nut</p>
<p>These always go in a nut access hole. They attach with no washer between the nut and the wood, to hex bolts.</p>	

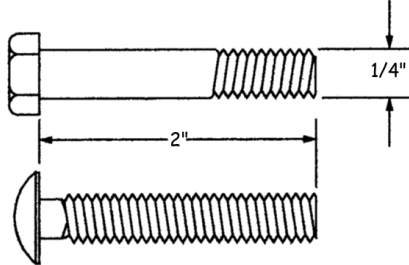
 <p>Figure 5 - Black Knob</p>	 <p>Figure 6 - Measuring Bolts</p>
---	---

INSERTING NUTS AND BOLTS

NOTE:

Given the limited space provided by the nut access holes, it can be challenging at first getting the nuts onto the bolt ends. You'll find it helpful to push each bolt in just until it just appears in the access hole. Move the nut into position over the end of the bolt and hold it with your finger. Slowly turn the bolt clockwise and when the nut engages, tighten it most of the way down.

If your fingers are too big to comfortably manipulate the nut, try holding it with a flat blade screwdriver or needle-nose pliers.

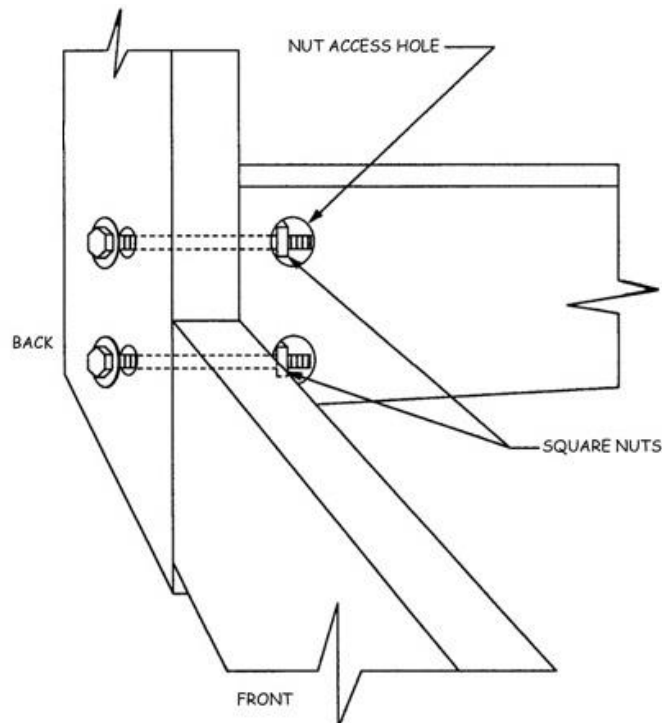

Figure 7 - Inserting Nuts

Note:

As you are building the loom, do not tighten the nuts all the way down. You will tighten everything down once you have squared and leveled the loom as described on page 29.

UNPACKING THE LOOM

Note:

Some of the pieces need to be unpacked in a specific way. Please unpack the side frames and the dobby according to the directions in the assembly section.

You will have several boxes containing the pieces of your loom. For the most part, you can leave pieces in the boxes until you are ready to work on a specific subassembly of your loom. Each box is numbered. Carefully remove packing material, making sure that small parts are not missed.

The K-series loom is shipped with motors and hardware in place. These will usually be protected for shipping with cellophane or bubble wrap held in place with tape. The end of the tape will be folded over, giving you a tab to grab and use to remove the tape. If you need to use scissors or a knife to undo any wrapping, please keep a layer of wrapping between the tool and the wood of your loom to avoid any blemishes.

Note:

Please DO NOT REMOVE the tape or other wrapping from any of the components until we tell you.

In some of the boxes you will find hardware packages. Each package is marked with the subassembly it goes to and the pieces within it. You should leave the hardware bags unopened until they are required.

Keep as many of your packing materials as you can in case you need to ship or store your loom in the future. Clear away your packing materials from your working space. It's best if you keep your work area as organized and free of clutter as possible.

You'll need a space about 5' x 5' to assemble your loom. In addition, a conveniently located desk or table will come in very handy for several of the operations.

Depending on your particular style of work, the entire assembly operation will take between three and eight hours.

UNPACK THE SIDE FRAMES

When you receive your loom, the side frames will already be assembled. The Compu-Dobby is attached to the right side frame. Hardware and cables will

already be attached. You will also notice that the rear cross member is included with the side frames and there are cables running between the right side frame and the rear cross member. Follow these instructions to remove the loom safely from the crate.

Note:

To remove the side frames and associated parts from the boxes safely and easily, please have two people working together.

- 1) Remove the packing material around the side frames.
- 2) Remove the manual, hardware packet, and power box.
- 3) Remove the left side frame. Place it out of the way for now.

WARNING:

The right side frame with the Compu-Dobby weighs about 140 pounds. Please have two people remove and hold it using safe lifting techniques.

- 4) Carefully remove the right side frame with the Compu-Dobby and the attached rear cross member. There are Styrofoam blocks between the side frame and the cross member.
- 5) DO NOT remove any wrapping, tape, or bags from the loom until told to do so. Do not remove the wrapping from the side frame and cross member until you have found the hardware and are ready to attach them together.

Note:

The weights at the bottom of the Compu-Dobby are held in place for shipping with a metal rod. Leave the rod in place while you are assembling the loom. Remove the rod before using the loom for weaving. Keep the rod safe so that it can be used if you need to move or ship your loom or Compu-Dobby.

INSTALL THE REAR CROSS MEMBER

- 1) Please locate the Hardware Pack for the cross members.
- 2) Sort the hardware. Select four 1/4x2-3/4" hex bolts, with square nuts. Remove the nuts.

Note:

The Lower Rear is connected to the Right Side Frame with cables, but it is not yet securely attached with bolts so be careful when moving and positioning.

- 3) The right side frame and rear cross member are held together with packing tape and cellophane. Find the end of the tape. There should be a tab at the end that you can lift to remove the tape. Unwrap the cellophane.
- 4) Remove the Styrofoam blocks. Leave any other wrapping or bags in place for now.
- 5) Locate the mounting holes for the Lower Rear cross member on the right side frame.
- 6) Position the Lower Rear cross member so that the mounting holes match. Have someone hold the lower rear cross member in position.
- 7) Insert two of the bolts through the holes in the right side frame, into the matching holes on the Lower Rear.
- 8) Add the nuts and tighten to secure the bolt. Do not completely tighten the nuts until you square the finished frame.
- 9) Add the left side frame in the same way. Position the left side frame so that the mounting holes on the side frame and lower rear match.
- 10) Push the bolts into place and add the nuts. Tighten to secure the bolt. Do not tighten completely until you square the finished frame.



Figure 8 - Rear Cross Member

Finish covering wires

There is a metal track embedded in the wooden horizontal which conceals the wires going from the motor to the power box. The wires are already embedded. If the loom is setup for two beams, with two brake motors, a connection cover is not needed.

- 1) Find the cover for the connection between the side frame and the rear cross member.



Figure 9 - Connection cover

- 2) Place the cover over the connection and push it into place.



Figure 10 - Connection Cover on loom

For now allow the wires to hang. They will be plugged in later.

INSTALL LOWER HARNESS PULLEY SUPPORT

- 1) Locate the harness pulley support assembly. It is made of two pieces of wood the width of your loom held together by two sets of pulleys.

Note:

The cable retainers mounted next to the pulleys will hold the assembly together until it has been attached to the loom. Do not remove the cable retainers until the lower harness pulley support assembly has been bolted to the loom.

- 2) In the hardware pack, find four 1/4x4 hex bolts with washers.
- 3) Orient the Harness Pulley Support Assembly at the bottom of the loom, so that the piece with square ends is at the front right of the loom.



Figure 11 - Bottom Harness Assembly from left

- 4) Align the four mounting holes in the Pulley Supports with those in the bottom horizontals.



Figure 12 - Bottom Harness Pulley Support Assembly

- 5) Insert the bolts through the top of the bottom horizontal and into the embedded bolt on the top of the bottom harness pulley support assembly.

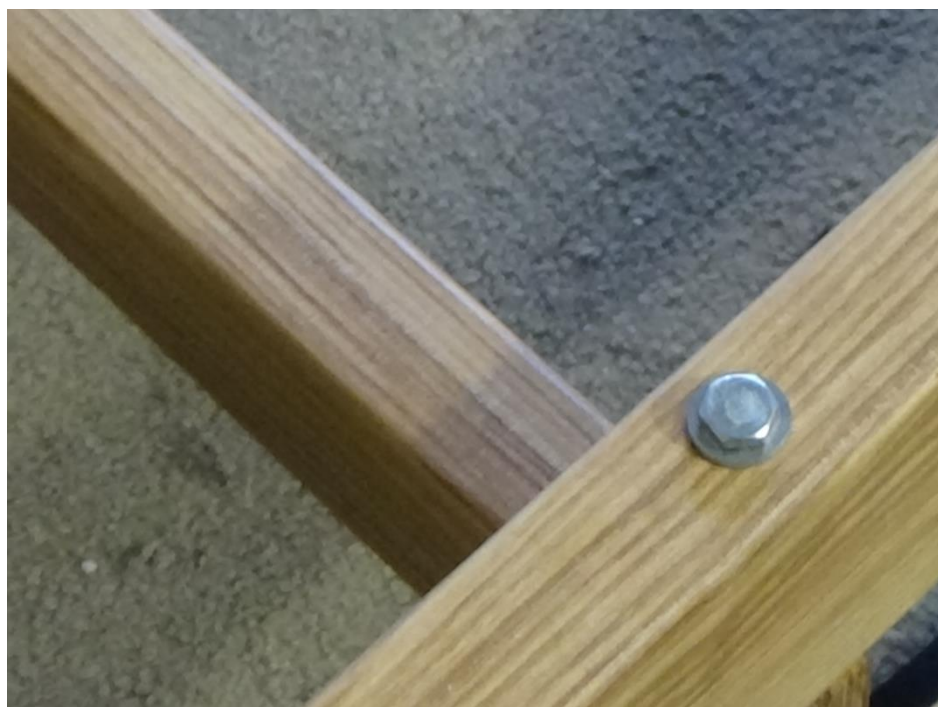

Figure 13 – Bolt for bottom harness pulley support assembly

- 6) Attach each of the four bolts.
- 7) Remove the cable retainers by removing the #8 screws. Place these in a safe location until you have installed the harnesses.

INSTALL THE FRONT TREADLE PULLEY SUPPORT WITH AXLE

- 1) In the hardware pack find four 1/4x2-1/2" Flat head machine screws with square nuts.
- 2) Position the rods with the treadles so that they fit into the bottom harness pulley support assembly.
- 3) Align the mounting holes in the front cross member with the holes in the side frame.



Figure 14 - Front Cross Member

- 4) Attach the front cross member to the frame with bolts.



Figure 15 - Front cross member attached to side frame

INSTALLATION OF LOWER FRONT ASSEMBLY

The nut access holes for the treadle cross member are at the bottom of the piece. In order to access them, the loom needs to be tilted back. Secure it in place by putting blocks of wood under the front. Because of the position of the nut access holes, the blocks should be placed near the outer edge of the loom side frames.

- 1) You will need to tilt the loom back and place blocks under the front to add the treadle cross member.



Figure 16 – Loom on blocks



Figure 17 – Closeup of blocks

- 2) Please locate the treadles, treadle cross member and the Hardware Pack.
- 3) Sort the hardware. Select four 1/4x2-3/4" hex bolts with washers and square nuts. Remove the nuts.
- 4) Locate the mounting holes for the Treadle cross member. There will be two mounting holes on each side frame.

Note:

The nut access holes on the treadle cross member are on the bottom of the cross member.



Figure 18 – Closeup of nut access holes

- 5) Have your helper take the Treadle cross member piece and place it between the two Side Frames, at the mounting holes.



Figure 19 - Treadle cross member

- 6) Attach the treadle cross member to the side frames using the bolts.
- 7) Remove the blocks from the loom.

INSTALL THE UPPER HARNESS PULLEY SUPPORT

- 1) Locate the harness pulley support assembly. It is made of two pieces of wood, a little wider than your loom, held together by three sets of pulleys, two sets of which are close to one end.

Note:

The upper harness pulley support is held together for shipping by the plastic wrapping. Do not remove any wrapping materials until the assembly is attached to the loom.

- 2) In the hardware pack find four 1/4x2-3/4" Hex bolts with washers.
- 3) Orient the Harness Pulley Support Assembly on the top horizontals, so that the end with the two rows of pulleys is at the right side of the loom and the small plaque with the loom's serial number faces the front of the loom. It should overhang about 4" on the right side.
- 4) Align the four mounting holes in the Pulley Supports with those in the Top Horizontals.



Figure 20 - Top Harness Pulley Support Assembly

- 5) Insert the bolts through the bottom of the top horizontal and into the embedded bolt on the bottom of the top harness pulley support assembly.



Figure 21 – Bolt for top harness pulley support assembly

- 6) Attach each of the four bolts.
- 7) Remove any wrapping materials from the top harness pulley support assembly.
- 8) Remove the top shelf by pulling the retainer pin (located at the back of the rear Harness Pulley Support) and sliding the board out to one side. Set the shelf aside while the harnesses are mounted into place.



Figure 22 - Shelf Retainer Pin

ATTACH THE LOWER TREADLE CABLE PULLEY GUIDE

This assembly, including cables, will be in a plastic bag hanging off the front of the dobbie.

- 1) Remove the assembly from the bag.
- 2) In the hardware pack, find two 1/4x4" flat head machine screws.
- 3) The screws go into the two holes near the dobbie on the front of the bottom harness pulley assembly.
- 4) Take the pulley assembly and hold it to the bottom of the front bottom harness pulley assembly.



Figure 23 – Lower treadle pulley assembly

- 5) Attach the pulley assembly with the flat head machine screws.



Figure 24 – Lower treadle pulley assembly from inside loom

SQUARING THE COMPLETED FRAME

Now that you have completely assembled the Loom Frame, it is time to make sure that the frame is square and level.

Please make a note of this process, as it is an important part of the maintenance of your loom. Your loom will perform better and give more years of service if this process becomes a part of your regular loom maintenance.

- 1) Using a tape measure, note these measurements:
 - a. Right front leg to left rear leg
 - b. Left front leg to right rear leg

- 2) These two measurements should match. If they do not, you will need to adjust the frame slightly, by pushing and pulling at the corners, until they do match. The frame will then be square.
- 3) Now, using a level, check the verticals at the corners and the cross pieces at bottom and top. Depending on the flooring, you may need to use shims under the four corner verticals in order to achieve level.
- 4) Once the loom is square and level, check and tighten all bolts and nuts that connect the frame pieces.

Over time, due to the shaking and movement the loom experiences during use, these connections will shake loose, requiring periodic checking and tightening. Make a check of these components a regular part of your loom maintenance.

INSTALL HARNESS ASSEMBLIES

It's time to add the Harness Cables and Harnesses to your loom. The harnesses for this loom consist of rigid wooden frames which hold metal rods. The metal rods are removable and will hold your heddles. The loom can use either metal heddles or polyester heddles. The loom comes with enough cable retainers to place on the bottom cables only.

Note:

The Compu-Dobby is secured with zip ties and the rod holding the weights in place. This helps hold the cables for the harnesses in the correct location. DO NOT remove the zip ties or the rod until the harnesses have been installed.

About the Harness Frames

The frames will take time and patience to install, however once they are installed, they will not need to be removed. The harness frames are packaged together for shipping. A sticker on the top harness will indicate the top and front of your harnesses.

Install the Harness Frames

- 1) If needed, remove the shelf as described earlier.
- 2) The harness cables are attached to the dobbie and bundled together. There is a set at the top and at the bottom. Remove the plastic bags and the twist ties.

Note:

It is easier to hang the harnesses beginning at the back of the loom and moving forward. Each harness cable has two loops that fasten to the hooks on the harness frame.

- 3) Take both ends of one of the top cables. Place the shorter piece over the middle pulley. Place the long end of the cable over the pulley furthest from the Dobbie.



Figure 25 - Placing top harness cables

Note:

Check that the cable is not twisted on itself — this will cause problems when you are weaving.



Figure 26 - Top harness cables

- 4) Take up a Harness Frame. Orient the frame so the hooks that are set closest together are at the **TOP** of the frame.
- 5) Hook the eyehooks at the top of the frame to the harness cable you just installed.



Figure 27 - Hanging harnesses, top cables

Note:

**Make sure the harness cables are traveling in a straight line to the hook on the harness. Holding the harness or cable at the wrong angle will make it more difficult to attach the cable to the hook.
Push the frame down if necessary to meet the cable.**

- 6) The bottom harness cables are connected to springs which connect to the dobbie weights. The springs and cables are secured to the loom for shipping. If anything has come loose, just hook the spring to the bottom of the dobbie weight, then the cable to the spring.



Figure 28 – Lower Harness Cable Springs

- 7) Find the correct cable for the bottom pulley and separate it into the long and short section.
- 8) Take the end of one of the bottom cables. Place the shorter piece over the middle pulley.
- 9) Place the long end of the cable over the pulley furthest from the Dobby.

- 10) Fasten the shorter pulley cable to the bottom eyehook on the right side of the harness.



Figure 29 - Hanging harnesses, bottom cables

- 11) Fasten the longer pulley cable to the bottom eyehook on the left side of the harness.
- 12) Repeat these steps for each harness.

Note:

Check your work periodically; it's easy to connect the wrong harnesses into the wrong set of eyehooks.

- 13) Replace the cable retainers for the bottom harness cables and screw in place. You removed these while installing the lower harness pulley support on page 22.

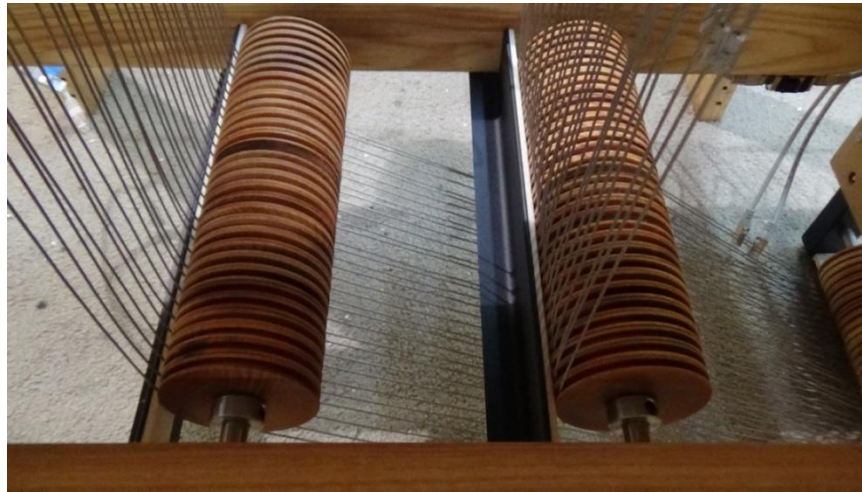

Figure 30 - Bottom harness cables with retainers

ADD HEDDLES TO THE HARNESES

The heddle support rods are held in the loom at the ends and in the middle with hooks. The hook in the middle will prevent you from moving heddles from one side to the other easily. Arrange your heddles so that you have the number you need on each side before you begin threading the loom.

Note:

The number of heddles provided for your loom depends on the width. For 24” looms 50 heddles per harness are provided. For 32” looms 75 heddles per harness are provided. For 40” looms 100 heddles per harness are provided. Additional heddles can be purchased from us if needed. Our heddles are bundled in batches of 100.

- 1) Pull the top heddle support rod up from the hook on one end and thread heddles on. Do the same for the bottom heddle support rod.
- 2) Move the heddles towards the center, pulling the heddle rods away from the center support as needed. Arrange the heddles so that they are balanced on each side.
- 3) Make sure the heddle rods are securely placed in the hooks when you have added all the heddles you need.

Note:

If you prefer, you can remove the heddle support rods completely from the loom to add heddles.

- 4) Repeat these steps to add heddles to each harness.

ATTACH THE TREADLE CABLES

Left Treadle

- 1) There are two cables coming off of pulleys behind the dobbie.



Figure 31 - Treadle cables

- 2) Take the top one that runs down to and under the groove of the pulley nearest to the front of the loom in the dobbie cam and pulley assembly.

- 3) Continue routing the cable through the loom and over the far left pulley in the treadle pulley assembly down to the treadle.



Figure 32 - Left treadle pulley with cable

- 4) There is a bolt going through the large access hole near the far end of each treadle. Remove the nut from the bolt in the left treadle.
- 5) Back the bolt out so that the end of the bolt is at about the middle of the large access hole.
- 6) Now slip the loop of the long cable you have just routed over the pulley over the end of the bolt.

- 7) Push the bolt back in and tighten the nut with a wrench. With the treadle hanging, the cable should be coming straight up from the bolt and over the left side of the left pulley.



Figure 33 - Left treadle cable on treadle

Right Treadle

- 1) Take the bottom cable that runs down to and under the groove of the pulley closest to the rear of the loom in the dobbie cam and pulley assembly.
- 2) Run the cable over the top of the pulley directly above the right treadle and down to meet the treadle.



Figure 34 - Right treadle pulley with cable

- 3) Pull the bolt out beyond the access hole as you did for the left treadle and secure the cable to the treadle by holding the loop in line with the bolt (inside the access hole) and passing the bolt through the loop and on through the treadle.
- 4) Replace and tighten the bolt and nut as you did on the left treadle.

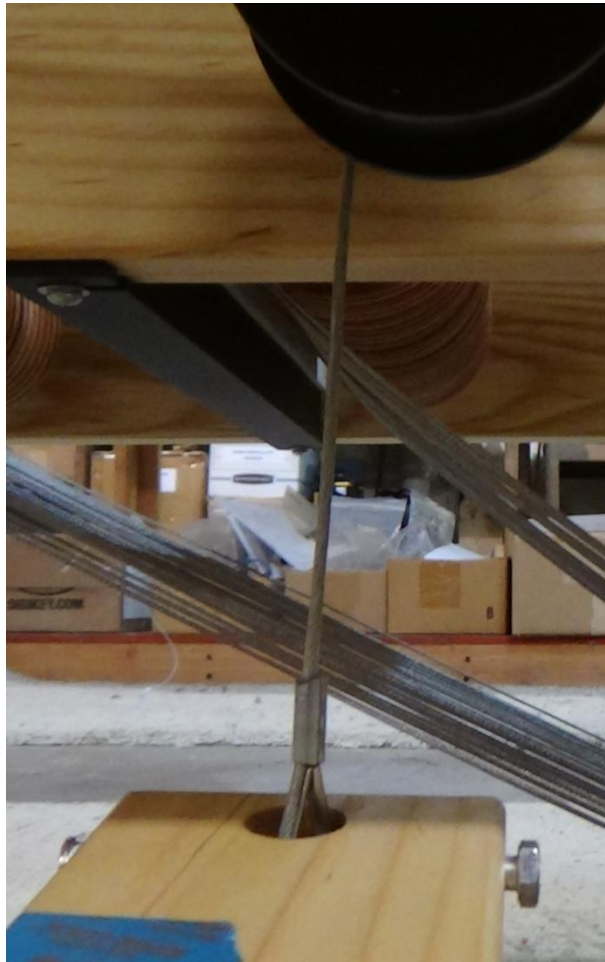

Figure 35 - Right treadle cable on treadle

PLACE THE POWER BOX ON THE LOOM

- 1) Find the power box. There are holes on the bottom which fit over pins.
- 2) The bottom pulley assembly has pins on the right side.



Figure 36 - Pins for power box

- 3) Place the power box on top of these pins.



Figure 37 – Power box on loom

INSTALL THE CLOTH STORAGE BEAM

- 1) On the left side of the loom, there is a rotating bearing. There is an arm with a screw at the top attached to the bearing.
- 2) Unwrap the bearing.



Figure 38 - Cloth Storage Bearing

- 3) Remove the retainer pin.
- 4) Locate the Cloth Storage Beam. The left end has a small cut out in it.
- 5) Place the left side of the Cloth Storage Beam over the bearing, so the cut out slips into place over the arm.
- 6) Adjust the beam so that the hole in the beam matches the hole in the bearing.

- 7) Place the retainer pin through the hole.



Figure 39 - Cloth Storage Beam Pin

- 8) On the right side, remove the pin from the support by removing the small hitch pin at the bottom.



- 9) Drop the right side of the Cloth Storage Beam into the support on the right side of the loom.



Figure 40 - Cloth Storage Beam

- 10) Replace the pin in the support and secure it with the hitch pin.

Tighten the clutch on the cloth storage beam

The Cloth Storage Bearing on the left side of the loom is attached to the beater. When the beater is brought forward, the cloth storage bearing advances the cloth storage beam taking up the slack in the cloth between the cloth beam and the cloth storage beam. Over time, the clutch in the bearing will wear out. The bearing is designed with a bolt that will allow you to re-tighten the clutch, so that the cloth storage beam will continue to work as designed.

- 1) Remove the retainer pin holding the cloth storage beam in place.
- 2) Remove the cloth storage beam from the loom.
- 3) Tighten the bolt on the cloth storage beam bearing on the left side of the loom. Tighten by twisting the bolt towards the inside of the loom until it is hand tight.



Figure 41 – Cloth Storage Bearing

INSTALL THE SWINGING BEATER ASSEMBLY

Your loom comes equipped with a Bottom Swing Beater.

- 1) The beater is shipped assembled. Remove the packing material and lift it out of the box.

- 2) There are supports for the beater hidden in the back of the front cross-member. Position the beater feet on top of these supports.



Figure 42 - Beater support pins

- 3) Lift the beater into the loom and over the front cross-member.



Figure 43 – Beater on loom

- 4) Connect the rod from the cloth advance to the beater.



Figure 44 – Beater attached to cloth advance

- 5) To remove the beater, unscrew it from the cloth advance, then lift it out of the loom.
- 6) To install a beater weight on the beater, use the threaded insert on the back. There is one on each side.



Figure 45 – Beater weight insert

TO REMOVE OR TO CHANGE THE REED

- 1) Loosen the bolts on the top and bottom supports to the reed.



Figure 46 – Loosen bolts

- 2) Slide the bottom support down slightly.



Figure 47 – Push down bottom support

- 3) Slide the reed out to the side.

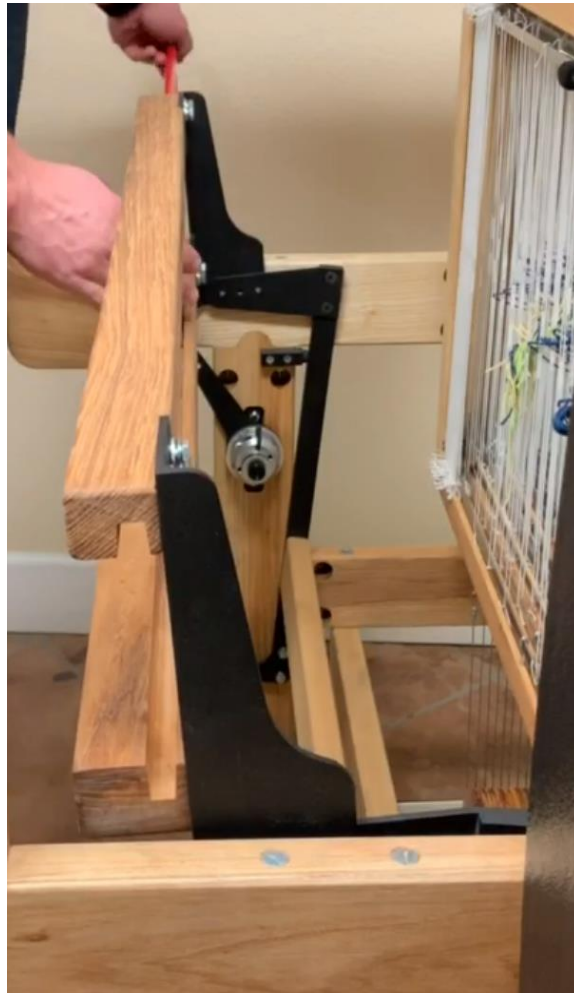

Figure 48 – Push the reed out

- 4) Slide the new reed in.



Figure 49 – New reed inserted

- 5) Make sure the reed is centered.



Figure 50 – Center reed

- 6) Make sure the top of the top support is even with the top of the bracket.



Figure 51 – Even top and bracket

- 7) Tighten the bolts on the top support.
- 8) Slide the bottom support back into position.
- 9) Tighten the bolts on the bottom support.

INSTALL THE CLOTH GUIDE ROLLERS

The cloth guide rollers guides the cloth from the sandpaper beam to the cloth storage beam.

Install the Rear Cloth Guide Roller

- 1) Locate the long black guide rollers.
- 2) The front beater bumpers have a support at the top for the cloth guide roller.



- 3) Drop the cloth guide roller into the supports on the beater bumpers.



Figure 52 – Cloth guide roller on loom

Install the Front Cloth Guide Roller

- 1) At the front of the loom near the warp beam support is a round guide roller support on each side.



Figure 53 – Guide Roller Support

- 2) Drop the beam into the supports.



Figure 54 – Guide Roller

INSTALL THE CLOTH BEAM

- 1) Remove the pins from the cloth beam holes.



Figure 55 –Cloth Beam pins

- 2) Put the left side of the beam in the hole on the left frame. The left side is the one without the gear.
- 3) Place the right side of the beam in the hole on the right side of the frame. You may have to push the frame apart slightly to fit the beam in.



Figure 56 - Cloth Beam

- 4) The gear at the end of the cloth beam fits into the grooves at the top of the cloth beam motor. Just put it in place.



Figure 57 - Cloth Beam motor

Note:

The ends of the beams have plastic bearings to ensure smooth rotation. Make sure the bearings do not fall off the ends of the beams.

- 5) Replace the pins to hold the cloth beam in place.



Figure 58 – Retainer pins for cloth beam

Install the Cloth Beam Cover

- 1) Place the cover into position over the cloth beam.
- 2) There are two small levers which lock the cover into position. Make sure the levers catch the cover.



Figure 59 - Cloth Beam Cover

- 3) To remove the cover, push the levers down and pull the cover away.

INSTALL THE UPPER (PRIMARY) WARP BEAM

The K-series loom is designed to carry two beams.

When using two beams at the same time, a second separation beam will need to be used.

If you are using a single Beam, install it in the upper position. The brake drum and tension system will be on the non-Dobby side of the loom (the left if you are in position to weave).

- 1) Locate your Warp Beam and the axle pockets located on the front edge of the Rear Verticals.

- 2) Loosen the screw that holds the flat beam retainers over the two pockets.



Figure 60 - Beam Retainer

- 3) Swing the retainers aside and position the Beam in place.
- 4) Bring the warp beam into position. If you are using the upper location, orient the beam so that the brake drum is opposite the Dobby Head.
- 5) Place the long spacer on the non-brake side of the warp beam.



Figure 61 - Warp Beam Spacer on non-brake side

- 6) Place the short spacer on the brake side of the warp beam.



Figure 62 - Warp Beam Spacer on brake side

- 7) Seat the beam in the axle pockets and, holding the beam in place, rotate each retainer back down, to safely secure the beam.



Figure 63 - Warp Beam

- 8) Locate the Warp Beam Handle and remove its hardware.
- 9) Slip the handle over the protruding end of the Beam Axle. Insert the bolt and secure with the washer and nut. Note that the handle is connected with a carriage bolt, the head of which must fit into a stamped recess.

Mount the Tension System

Note:

Once you install the tension cable, you will only need to remove it if you remove the beam.

- 1) The tension motor is already installed on the side frame. The motor on the non-dobby side is for the upper beam.
- 2) The cable for the tension system is attached to the eyehook on the side frame. Remove the twist tie.



Figure 64 - Tension system from back of loom

- 3) Bring the cable immediately up and around the top of the Brake Drum. Start at the end of the drum nearest to the handle. Wrap the cable around the Brake Drum; it will pass over the top of the drum three times. Take care **not** to cross the cable on itself.
- 4) When you've just enough cable remaining to almost reach the motor, attach the snap hook to the eyehook at the top of the motor.



Figure 65 - Tension system from inside loom

Note:

Check again to make sure the cable isn't crossed on itself.

Note:

If the cable is installed in the wrong direction the Beam will turn easily toward the front of the loom and you will be unable to establish good tension.

INSTALL THE LOWER (SECONDARY) WARP BEAM

For the lower beam, the brake drum and tension system will be on the Dobby side of the loom (the right if you are in position to weave). Installation is the same as for the upper warp beam.

- 1) Locate your Warp Beam and the axle pockets located on the front edge of the Rear Verticals.

- 2) Loosen the little bolts that hold the flat beam retainers over the two pockets.
- 3) Swing the retainers aside and position the Beam in place.
- 4) When using the lower position, place the handle at the right side of the loom. Place the left side of the beam into the retainer pocket first. Rotate the retainer back down.
- 5) Place the long spacer on the non-brake side of the warp beam.
- 6) Place the short spacer on the brake side of the warp beam.
- 7) Since there is not much room for the lower beam, it is easiest if you add the tension cable before placing the right side of the beam in the pocket. Hold the right side of the beam slightly above the floor.

Mount the Tension System

Note:

Once you install the tension cable, you will only need to remove it if you remove the beam.

- 1) The tension motor is already installed on the side frame. The motor on the dobbie side is for the lower beam.
- 2) The cable for the tension system is attached to the motor. Remove the twist tie.
- 3) Bring the cable immediately down and around the bottom of the Brake Drum. Start on the side closest to the beam. Wrap the cable around the Brake Drum; it will pass under the drum three times. Take care **not** to cross the cable on itself.

- 4) When you've just enough cable remaining to almost reach the eyehook, join the coil at the end of the spring to the eyehook using a small pair of needle nose pliers.



Figure 66 - Tension system for second beam

Note:

Check again to make sure the cable isn't crossed on itself.

- 5) Seat the beam in the right axle pocket and, holding the beam in place, rotate the retainer back down, to safely secure the beam.



Figure 67 – Loom with two warp beams

- 6) Locate the Warp Beam Handle and remove its hardware.
- 7) Slip the handle over the protruding end of the Beam Axle. Insert the bolt and secure with the washer and nut. Note that the handle is connected with a carriage bolt, the head of which must fit into a stamped recess.

Note:

If the cable is installed in the wrong direction the Beam will turn easily toward the front of the loom and you will be unable to establish good tension.

Install the Separation Beam

If the loom has two warp beams, the warp from the upper beam will go over the separation beam closest to the interior of the loom. The warp from the lower beam will go over the outer separation beam.

- 1) Drop the separation beam into the supports.



Figure 68 - Separation Beam

INSTALL THE SHELF

- 1) Orient the shelf so that the felt strips on the bottom will lay atop the three sets of Harness Pulleys when the shelf is in place. These act as Cable Retainers and will keep your Harness Cables properly located during lifting of the harnesses.
- 2) Slide the shelf into the grooves in the Harness Pulley Supports.
- 3) Insert the retention pin into its hole. It will, and should be, tight. It will loosen over time.



Figure 69 – Shelf in place on loom

- 4) If you cannot push the pin all the way into the shelf, check that you haven't put the shelf in backwards.

CONNECTING THE COMPU-DOBBY

The Compu-Dobby on this loom looks rather different from its predecessors, however it works similarly. Many of the differences are related to the new functions it controls.

- 1) Unscrew the thumbscrews on the Compu-Dobby cover.

- 2) Lift off both parts of the cover.

Note:

The back of the top part of the Dobby cover has a layer of blue insulation to help muffle the sound of the dobbie.

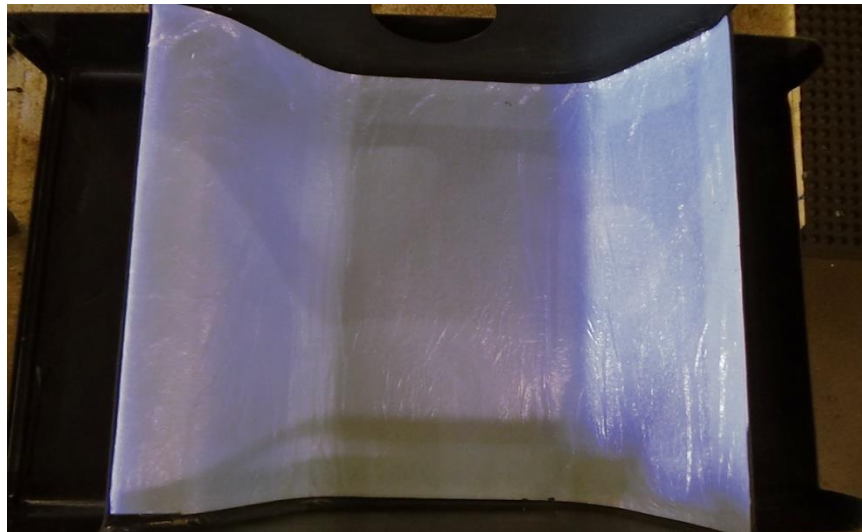

Figure 70 – Dobby with sound insulation

- 3) The weights at the bottom are held in place for shipping with a metal rod. Remove the rod before using the loom for weaving. Keep the rod safe so that it can be used if you need to move or ship your loom or Compu-Dobby.



Figure 71 - Dobby weights with rod

- 4) The dobbie is also secured with straps that make sure the slide plates will not move during shipping. You will be able to cut these straps with scissors.

- 5) Place the cover onto the Dobby Back and secure it with the thumbscrews.

Note:

We strongly recommend that you use an Uninterruptable Power Supply (UPS) for your loom. The loom is “always on” so that it will boot up quickly and does not need to be shut off. If you remove the loom from a power source, you should go through the shutdown sequence in the software first.

- 6) The cables from the loom frame and the power box plug into a coupler attached to the bottom of the bottom harness assembly. Plug those in now.



Figure 72 - Cable coupler

- 7) Locate the cable that goes from the box to the Compu-Dobby and plug it into the power box.
- 8) Locate the power cable and plug it into the box.
- 9) Plug the loom into a power supply.

- 10) Plug the USB cable included with your Compu-Dobby into the USB port and plug the other end into your computer. You can also access the loom through wi-fi, or a router.



- 11) Refer to the Compu-Dobby V manual for information on using the loom.

Note:

Remove any remaining packing materials. Your loom is now ready to weave with.

ADDITIONAL LOOM OPTIONS

ROTARY RING TEMPLES

Rotary Ring Temples are an upgrade available for this loom. The K-Series comes with hidden, built-brackets making ring temple installation quick and simple.

The Temple System is used to maintain a good selvage and prevent draw-in. You'll usually deploy it after you've woven-off some fabric, once you have selvage enough to work with. It consists of two rollers (barrels), working in tandem, which grab the selvage and prevent it from drawing in.

Ring Temple System Assembly

It is best to install the rod and supports before tying on your warp. The ring temple cloth guides can be put on after you have woven enough yardage to get your apron rods around the front beam.

Note:

The ring temples should be installed so that the temple is closest to the inside of the loom. If they are installed closer to the cloth beam, the cloth beam cover will not fit on the loom.

- 1) Find the ring temple supports and make sure the knob is in place for tightening.



Figure 73 – Ring temple support with knob

- 2) Slide the supports on the ring temple rod. Tighten down the knob so that the supports will stay in place.



Figure 74 – Ring temple supports on rod

- 3) Locate the brackets for the ring temple system, which are hidden in the support for the sandpaper beam.



Figure 75 – Ring temple bracket

- 4) Place the rod in the brackets. Lock it down with the screw knobs.



Figure 76 – Ring temple rod on loom

- 5) Adjust the position of the ring temple supports and place the ring temples in the support once you have enough cloth on the loom. Lock the ring temple in position with the nut.



Figure 77 – Ring temple on loom



Figure 78 - Ring Temple on Fabric

Further information on using the ring temples when weaving can be found in the Weaving section of this manual on page 121.

TRACK & MOUNT

The optional track and mount system mounts directly to the rear vertical side frame members to provide a stable platform for a tension box.

Installing Track and Mount Mounting Studs

- 1) In your tension box hardware bag, find four 5/16" x2-1/2" carriage bolts, black discs and bushings, washers, and hex nuts. They are called track arm mount studs.
- 2) Install this assembly, from the outside of the loom, through one of the two holes provided on either rear vertical.



Figure 79 – Track and Mount support with bolt

- 3) Slip the washer and nut on the inside of the loom frame and tighten with a 1/2" socket wrench.
- 4) Repeat this process with the remaining bolts.



Figure 80 – Track and Mount supports

Attaching the track to the track arms

- 1) Place the track so that the lengthwise groove is on top.

- 2) Mount the track to the brackets on the track arms using two 5/16" x 2-1/2" hex bolts, washers, and square nuts on each side.

Mounting the Track and Mount on the Loom

The AVL tension box track mounting system employs a quick release.

- 1) To install the track/arm assembly, place the track arms between the two externally mounted studs that you attached to each rear vertical of the loom.
- 2) The track arms should initially go in at an angle with the front stud fit into the notch on the upper edge of the track arm.
- 3) Then lower the track/arm assembly to a horizontal position at which point the lower notch on the track arm should align with the rear stud.



Figure 81 - Attach Track & Mount Arms

- 4) This will hold your tension box in place while warping your loom. When you are finished with the tension box, the track can be removed easily.

RADDLE

The raddle is inserted into the holes in the back edge of the rear vertical side frame members. You can mount the raddle here for warping the standard beam in either upper or lower positions.

- 1) Make sure that the removable portion of the raddle is to the top.

- 2) Once mounted into the holes, the raddle is not only held firmly in place, but is also perfectly centered and can be left in place while weaving.



Figure 82 – Raddle on loom

CASTERS

One of the available options for the K-series loom is wheeled casters which allow the loom to be easily moved from one location to another. When the loom is not being moved, the casters are securely locked into position.

Note:

The casters at the front of the loom are positioned at the sides. The casters at the rear of the loom face the back.

- 1) Find the four casters and the hardware. There are four long bolts and four short ones.
- 2) Place two casters at the front of the loom against the pre-drilled holes on the side frames, with the bracket facing up. Place the short bolts through the holes in the caster and the loom from the inside of the loom.



- 3) Secure each bolt with a nut.

- 4) Place two casters at the rear of the loom against the pre-drilled holes, with the bracket facing down. Use the long bolts to secure the casters to the loom.



WEAVING INSTRUCTIONS

Note:

Unless otherwise noted, the instructions in this section are basic, general instructions for weaving and are applicable to many AVL and non-AVL looms. They should not be regarded as a substitute for training or experience.

LOOM ORIENTATION

Before you get started, please take a minute to familiarize yourself with how we describe the loom in this manual.

The front of the loom is where you will sit; the back of the loom is where the warp beam is.

Everything is referenced as if you were sitting in the weaving position. The right side of the loom is the side to your right as you are sitting at the loom and the left side is to your left.

The right and left of the dobby head is referenced as if you were standing right in front of it.

The new Compu-Dobby gives you incredible control over your weaving. However, like any new process, there will be a learning curve while you adapt to the new technology. For best results, completely read this weaving section and the Compu-Dobby/AVL Drive Manual that came with your loom before weaving.

WARPING THE LOOM

AVL advocates warping from back to front. We believe that this system works best with our looms and our warping tools are designed around this philosophy. If you prefer other warping methods, you will be able to adapt them to work on your new loom. However, we suggest you study the following warping techniques and try them out to get the most out of the Workshop Dobby Loom.

To learn more about your AVL loom and to learn how to get the most out of it, you may want to take a class at the AVL Weaving School. Complete information and a current class schedule can be obtained by phoning the AVL office (1 800 626-9615 or 530 893-4915) or on-line at <http://www.avlusa.com/workshops>.

Visit our youtube channel at <https://www.youtube.com/user/avllooms> for videos on assembling and using our looms.

WARPING DIRECTION

The warp needs to be wound on to the warp beam in the opposite direction from the way it will wind off when weaving.

The nature of the warp tension system on the K-Series loom means that the warp beams only work properly when wound in the correct direction (as shown in figure Figure 83). If the warp is wound on in the wrong direction, the only option is to take it off and start over. The warp beams should rotate more freely in the direction you'll need to wind on. If you feel like you're forcing the beam to wind on, you may be going in the wrong direction. Keep in mind that the TOP beam comes off the TOP. And the BOTTOM beam comes off the BOTTOM. This may be different than other AVL looms that you've woven on, so refer back to this diagram as needed.

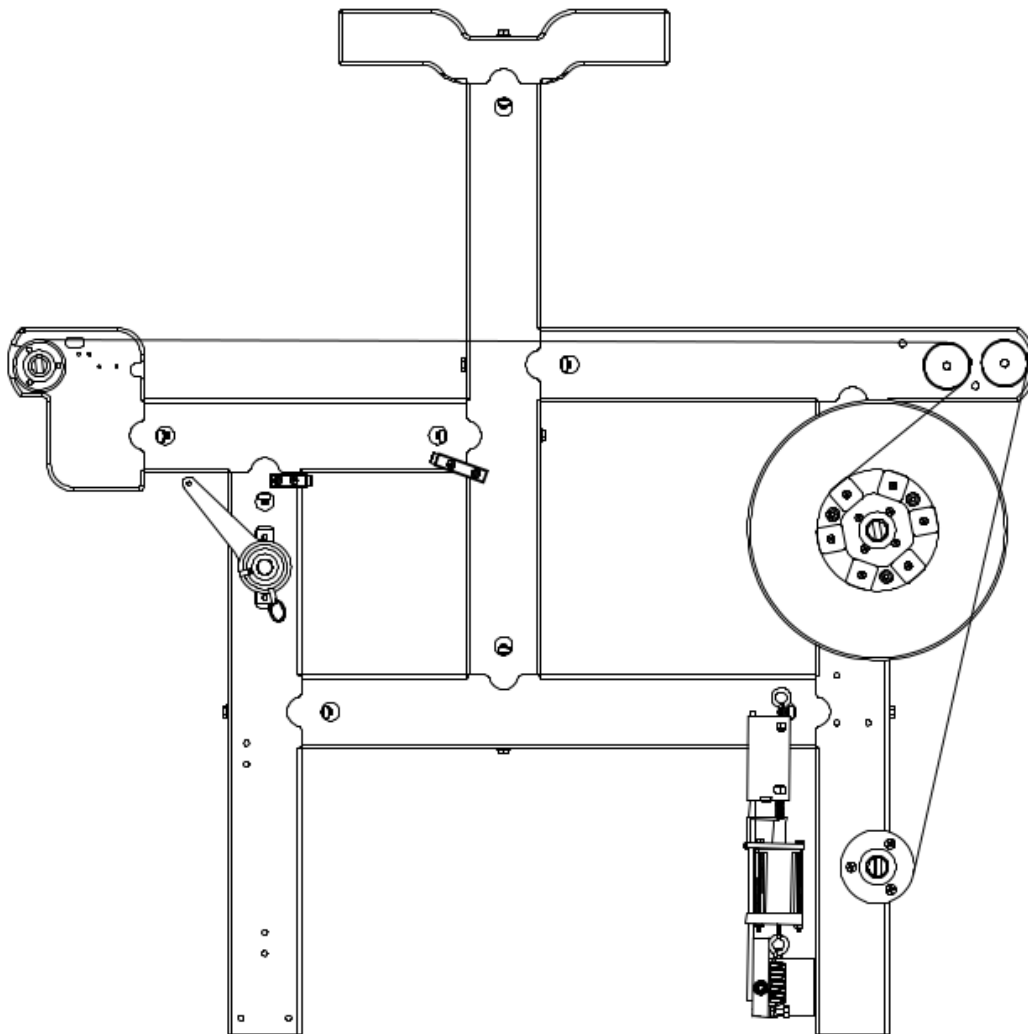

Figure 83 – Warp routing

The K-series loom can have two warp beams. The warp comes off the top of the top warp beam, and from under the bottom warp beam.

The handle for the top warp beam will be on the left side of the loom (when you are in weaving position). It will be moved clock-wise when warping. The handle for the bottom warp beam will be on the right side of the loom. It will also be moved clock-wise when warping.

For both beams when weaving, the warp will come off the beam, up and over the separation beam, and into the heddles.



Figure 84 – Warped beam from back



Figure 85 – Warp threads entering the heddles

WARPING THE PLAIN BEAM

If you only have a Sectional Beam, proceed to the section titled *Warping the Sectional Beam*.

Various warping methods can be adapted to an AVL loom. However, we recommend the following method in which the warp is wound on to the Plain Beam with the use of a Raddle. Please study this method and try it. We have found that it aids in getting a uniform warp tension, especially when dealing with long warps.

Creating Two Crosses

To begin, wind the warp on a warping board or reel. Make sure you put in two crosses, one at each end of your warp:

- 1) The Threading Cross (each thread crosses the next thread in opposite directions; all are secured in a single loop).

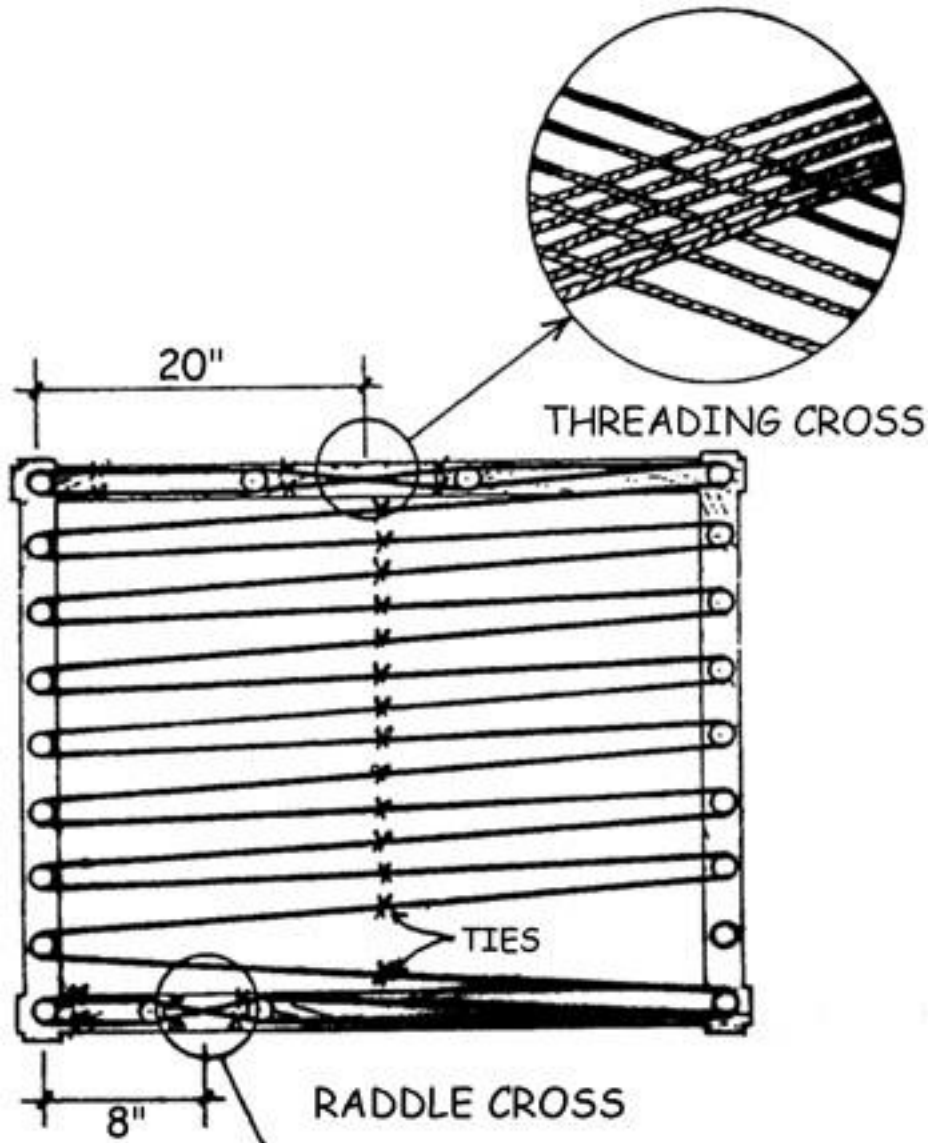

Figure 86 - Warping Board with Two Crosses

- 2) The Raddle Cross (warp threads are tied in groups, depending on how many ends will be put in each section of the raddle).

Securing The Crosses

Before removing the warp from the board or the reel, secure the crosses. Use four ties to secure each cross, in addition to the tie at the cross axis. These ties go on each side of both pegs holding the cross.

It is usually a good idea to use different color threads for the ties on the tops of the pegs and another color to tie the bows underneath the pegs. By color-coding your ties, you are less likely to twist the warp later.

Removing The Warp From The Warping Board

Remove the warp from the warping board by chaining or by winding on the kistestick. Start from the Threading Cross and proceed to the Raddle Cross.

Since the capacity of the warping board is limited, for wide warps you will end up making a number of mini-warps and taking them off individually.

Attaching The Raddle

Secure the Raddle to the back of the loom. If you have an AVL Raddle, simply slip the mounting rods into the set of holes in the back of the rear vertical members.

Winding The Apron

Put your apron on the beam with velcro and wind your top beam clockwise, so that your apron is wound on the beam.

Attaching The Warp To The Apron

Bring the apron around the Separation Beam and put the metal rod through the sleeve at the end. You can lash your warp sections onto that rod or you can attach another rod which has been slipped through the loop at the end of the warp with the Raddle Cross.

Inserting Sticks In The Raddle Cross

Place two lease sticks in either side of the Raddle Cross and secure together with string through the holes in the ends of the sticks. Now remove the ties from the Raddle Cross and spread the warp out on the sticks.

Measure the center of your Raddle to use it as a center of your warp. The warp threads should either go through the middle of the Raddle.

Feeding The Raddle

To feed the Raddle, distribute yarns across the Raddle by dropping each Raddle Cross group into a dent in the Raddle.

If you are using an AVL Raddle with a sliding cover, slide it on after the Raddle is threaded and secure it with two or three cord ties so it can't come off. Remove the Raddle Cross sticks when this is completed.

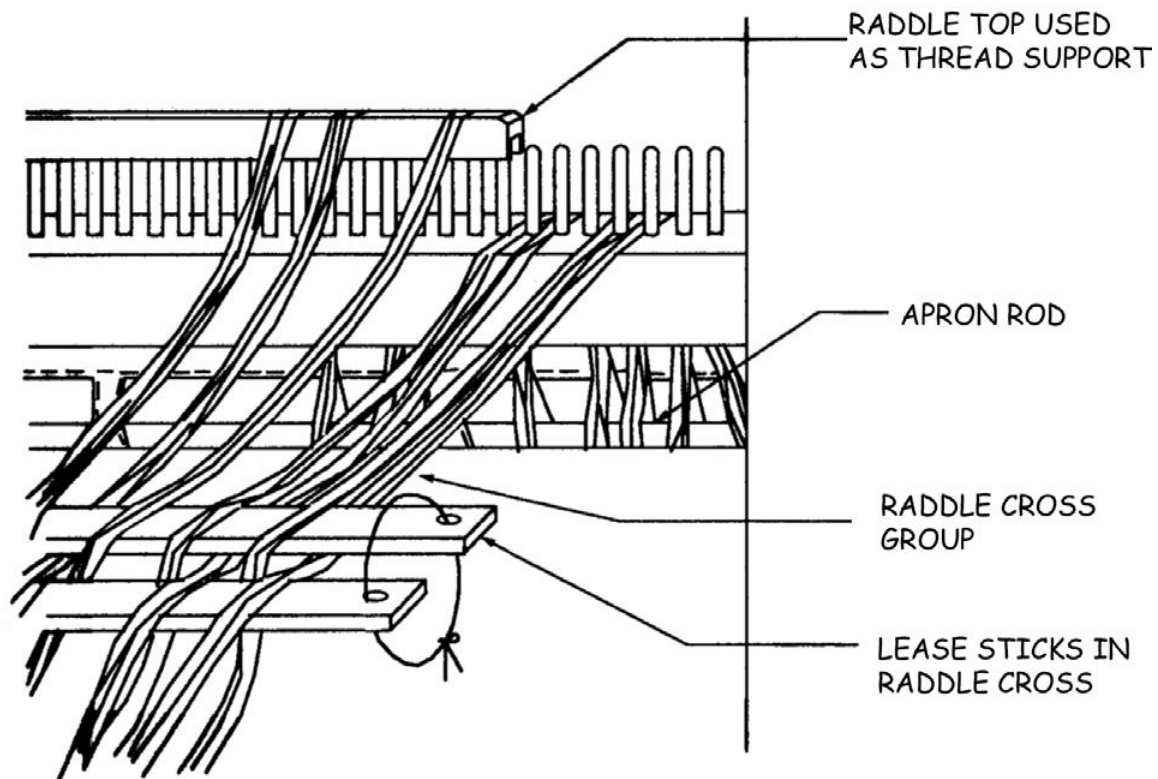

Figure 87 - The Raddle and the Raddle Cross

Preparing The Paper

Prepare the paper for winding between the warp layers. For the most professional results, and fewer tension problems, we suggest that the warp be as smooth, tight, and compact as possible. This would mean not using corrugated paper or sticks as they will make the warp too soft and/or lumpy. Corrugated paper is just too soft and the warp can never be wound tight enough with it. Heavy wrapping paper works well; seventy pound craft paper is good. If you are going to be using smooth, slippery warp yarns like fine linens or perle cottons, the edge yarns are going to need extra help in order not to slip off the sides. To do this, cut your paper four inches wider than the

warp width and then fold over the edges an inch on each side. Be sure the warp is wound between the two folded edges not overlapping them.

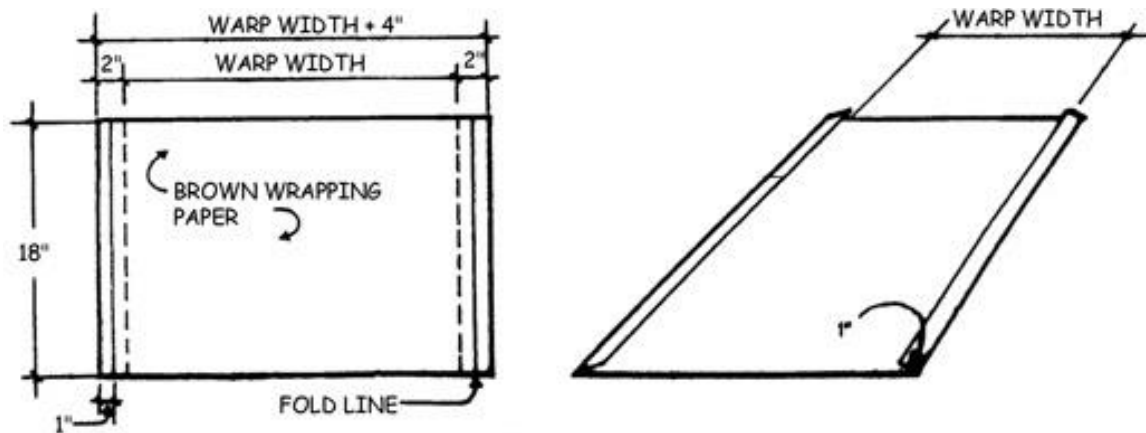

Figure 88 - Prepared Paper with Folded Edge

Winding The Warp

Remember, wind the warp on tightly under a lot of tension. The amount of tension used will vary depending on the warp material, but a good rule to remember is that the tension of the wound-on warp must be as great as the tension during the weaving operation. You will need one person to hold a warp under tension on the back and one person to wind the warp on the beam using a handle. The person winding the warp can also insert the paper. For a wide, heavy warp, several helpers may be required.

If you have to do it yourself, you can use the jerking method. Make one turn around with your beam crank and then go to the back of the loom and jerk one narrow section (2-3 inches in width) at a time to make the newly wound warp tight on the beam. The idea of this method is that the warp does not need to be under tension all the time, but the part that is on the beam has to be tight. Make another turn, go to the back of the loom, and jerk all the sections again and so on. If you have a wide warp, you might need to do multiple jerking motions after each turn.

Threading Cross

When you come to the end of your warp, insert lease sticks at either side of your Threading Cross. Tie the two sticks together at each end.

Removing The Raddle

When the warping is completed, free the warp from the Raddle. If you have an AVL Raddle, first untie the security strings, lift the Raddle top off, and remove the warp from the Raddle. Afterwards, replace the top on the Raddle and leave it in its place on the back of the loom as it will not interfere with the weaving process. Then be sure to bring the end of the warp around the Separation Beam so that it now travels into the loom.

Using a strong cord, suspend the lease sticks between the Separation Beam and the Harnesses.

Now remove the ties from each Threading Cross and spread the warp out on the sticks.

Using Two Beams

There will be times when you will want to use more than one warp, which cannot be put together on one beam.

Ideally, you will put them on separate beams with separate tension systems.

When Do You Need To Tension Your Warps Separately?

When weaving:

- Very different size yarns.
- Yarns with different stretching qualities.
- Different densities.
- Different structures.
- Supplementary warp techniques (because some warp threads do not interlace as often as others).
- A group of special yarns for selvages and borders. Loops, piles, or puckers like seersucker.
- More than one layer with different setts in each layer.
- More than one layer with a different pick count in each layer.

Setting Two Beams

The process of setting up a second beam is the same as setting up one beam. You need to be careful not to mix sequences between the beams. It will also take more time to setup two beams rather than one.

The K-series loom allows you to have two beams on the loom. The second beam is placed in the bottom position, with the handle on the right side of the loom.

- 1) Wind each warp on the beam the same way you would do it if there were only one beam on the loom (plain or sectional). Make a cross and have a pair of lease sticks with a cross in each warp.
- 2) The warp from the upper warp beam goes over the separation beam closest to the heddles. The warp from the lower warp beam goes over the separation beam furthest to the back.
- 3) Proceed with threading as if you were only working with one beam. Follow your threading instructions and take special care which thread from which pair of lease sticks comes next.

More Than Two Warps, Only One Beam? Separate Tensioning!

If you do not currently have two beams, or you need more than two separate warps, you can weight and tension your additional warps separately on the same beam. Follow the instructions below.

- 1) Make your warp sections on the warping board and take them off the board in a chain, on a kite stick, or just in a plastic bag.
- 2) Make sure that each bundle is not too thick. You will know when you need to divide each bundle if you feel that all the threads are not being tensioned evenly.
- 3) The weight needs to have a strong loop of string on it so the warp bundles can be slip knotted into it. This makes it easy to undo the slip-knot and move the weight when it climbs up to the back beam and must be let down again.
- 4) The weight also needs to be adjustable. Plastic bottles, with handles, filled with water are perfect. You can also use fishing weights, washers, nuts, bolts. They are not as easily adjustable as water bottles, but take less space. The closer to the floor you can hang them, the less often you need to reposition them.

WARPING THE SECTIONAL BEAM

The AVL Sectional Beam can be warped in sections with the use of a Tension Box. The yarn travels directly from cones or spools, which are mounted on a rack behind the loom, through the Tension Box, and onto the Beam.

Throughout the warping process, the Tension Box automatically keeps a constant and uniform tension on the warp. The Tension Box allows you to make longer warps than other methods.

You can also warp a sectional beam using the AVL Warping Wheel. With the AVL Warping Wheel you wind threads onto the wheel then wind them from the wheel directly onto the beam. When using a warping wheel, your warp length will need to be less than 24 yards.

Extension Cords

You might want to make a permanent set of Extension Cords to use when warping the Sectional Beam. Extension Cords are also called “apron cords” and serve the same function as the apron on the Plain Beam. They give you “reach” from the Warp Beam and allow you to weave every possible inch until the end of the warp touches the last Harness you are using. Make them out of a strong non-stretchable linen or cotton cord. You will need to make one Extension Cord for each section in your Sectional Beam. For each Extension Cord:

- 1) Measure a piece of cord long enough to reach from the axle of the Warp Beam, at least one and a half revolutions around the Beam and then reach to the back most Harness.
- 2) When measuring the length of the cords, take into account that, when the warp is attached to the Extension Cord the knot between the cord and the warp needs to fall between the Crosspieces of the Sectional Beam, not on them. This will keep the warp smooth on the Beam so it doesn't go over the knots created when attaching the warp to the cords.
- 3) Now double that length and cut it. All Extension Cords should be exactly the same length, so cut them all at the same time.
- 4) Take the two ends of the cord and knot them together, using an overhand knot.
- 5) Wrap the cord around the center bar of the sectional beam with a larks head knot. You will also use a larks head knot to secure the warp threads to the extension cord.

Using a Tension Box

The Tension Box is an essential tool for Sectional Warping, which:

1. Puts threads under even tension.
2. Spreads threads to the proper width of the section.
3. Makes a thread-by-thread cross.

Sectional Beam Calculation

First, you must calculate the number of spools or cones of yarn you will need. Each section is wound onto the Sectional Beam separately; therefore, you'll need to have one spool or cone for each end in that section. For example, if your section is 2" wide, with sixteen E.P.I., you would need thirty-two spools or cones of yarn.

To prepare for Sectional Beam warping, we need to calculate:

- **NUMBER OF SPOOLS?**

Sectional Beaming requires the use of as many spools loaded with thread per individual section as your Ends Per Inch, or planned sett in the reed, dictates.

To calculate the actual number of spools required, we need to know:

1. how many EPI (this is the sett) are you going to use in the warp
2. what SIZE of SECTIONS (1" or 2") will you use on the Beam

If your warp is set at 24 epi per 1", you will need 24 spools for a Sectional Beam with 1" sections or 48 spools for a Beam with 2" sections.

OF SPOOLS = EPI x SIZE OF THE SECTION

- **NUMBER OF YARDS PER SPOOL?**

To calculate the number of yards per spool, we need to know:

1. the LENGTH OF THE WARP
2. NUMBER OF SECTIONS on the Beam

We calculate the number of sections by dividing the WIDTH OF THE WARP by the SIZE OF THE SECTION. If the warp width is 30" and we are using 2" sections, our number of Sections is 15.

OF YARDS PER SPOOL = LENGTH OF THE WARP x # OF SECTIONS

- ***TOTAL YARDAGE?***

If it is a single color warp or if a color sequence is repeating in each section, the same spools or cones can be used to wind all the sections needed for the warp.

TOTAL YARDAGE = # OF SPOOLS x# OF YARDS PER SPOOL

It is important to make these calculations in advance so that you can purchase your yarn in spools or cones corresponding to the amount of yardage needed on each. Sometimes this is not possible and you will need to wind your own spools from yarn that is in larger packages. For doing this, you will need empty plastic spools, a bobbin winder (preferably electric), and a yardage counter. These items are available from AVL.

Feeding The Spool Rack

Once you have completed the calculations, place a Spool or Cone Rack about five or six feet behind your loom. Place the spools or cones for the first warp sections on the Cone Rack.

Make sure you put each thread through the metal eye on the spool rack so the threads do not get tangled.

When arranging the spools on the Spool Rack, it doesn't matter whether you go top to bottom or bottom to top, the important thing is to be consistent in vertical columns and to place the spools in the order that the threads are in the warp.

Tension Box Heddle Installation Instructions

The first time you use a Tension Box, you need to install heddles on the harnesses of your Tension Box.

Your Tension Box is delivered with one bundle of one hundred heddles. These are held together with twist ties. Leave these on for now. Refer to the following diagram to familiarize yourself with the Tension Box and its parts.

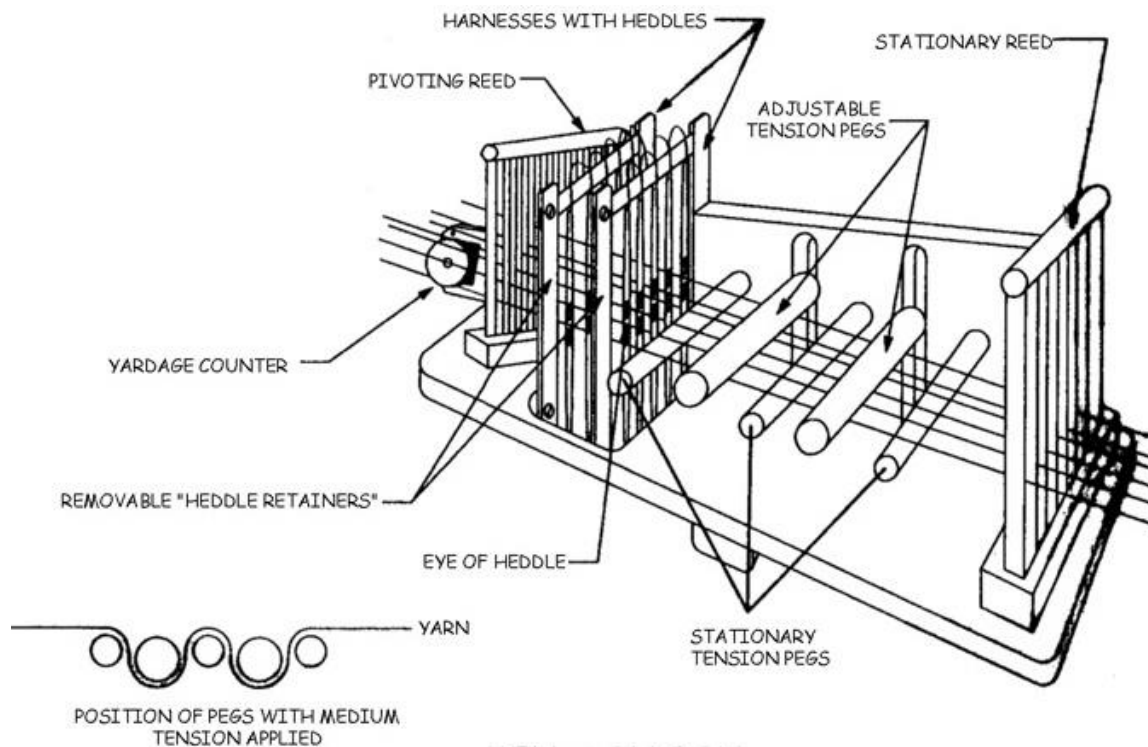

Figure 89 - Tension Box

- 1) Push down on one of the harnesses until it stops. This causes the other harness to go up. You will use that later for making a Threading Cross. Right now we'll need to use it to help put the heddles on the harnesses.
- 2) Remove the "heddle retainer" of the harness that is up, using a phillips head screwdriver.
- 3) Notice there are four twist ties holding the heddles together. Separate the top two. Insert the top bar (of the harness that is up) into the space created by pulling apart the twist ties. Insert the bottom bar (of the harness that is up) into the space created by pulling apart the bottom two twist ties, making certain that the heddles aren't twisted. Now remove the twist ties.
- 4) Count off fifty heddles and cut the loop at the top between the 50th and the 51st heddle.
- 5) Now put the four twist ties back on the fifty heddles that were the last to go on the harness.
- 6) Remove these fifty and reattach the "heddle retainer".

- 7) Now push down on the harness that is up, making the other harness come up.
- 8) Remove the heddle retainer.
- 9) Pull apart the top two twist ties and insert the top of the harness (which is up) into the space created. Pull apart the bottom two twist ties and insert the bottom of the harness into the space created.
- 10) Reattach the heddle retainer.

Positioning The Tension Box

Mount the Tension Box in the groove, with the Counter facing into the loom. The Tension Box is fastened to the Separation Beam with a small cross piece and wing nuts. This will stabilize the Tension Box and allow it to travel smoothly from one section to another. The wing nuts can be released for the Tension Box to move easily from side to side. Each time the Tension Box is moved and centered properly for a particular section, the wing nuts must be tightened again.

Threading The Tension Box

The best way to thread the Tension Box is to take one thread from the furthest left cone (as you face the Cone Rack, with your back to the loom) and thread it all the way through all the parts of the Tension Box, nearest to the back plate of the Box, then the next thread all the way through. It works best to use the threads from the rack in a vertical order rather than a horizontal order.

Now let's go through the sequence for threading the Tension Box. First, move the two adjustable Tension Pegs up above the Stationary Pegs or remove them completely. Now, using a sley hook, draw the thread through the Rear (stationary) Reed. Since this reed is eight dents per inch, you will divide the E.P.I. into eight to find out how many ends will be in each dent (with sixteen E.P.I., put two ends in a section). If your E.P.I. does not divide equally by eight, you can either vary the number of ends in each dent (with twenty E.P.I., alternate two and three ends in the dents) or thread the dents a little wider than two inches (with twenty E.P.I., put two ends in each dent; with forty ends, the reed will be sleyed 2-1/2" wide).

Next, bring the thread straight through the Tension Peg section, between the larger adjustable Tension Pegs and the smaller, stationary Pegs or just above the smaller stationary Pegs if you have removed the larger ones.

Thread the first end through one heddle on the Front Harnesses, nearest to the back plate. The next end will go through the first heddle on the rear Harness. Repeat this, alternating harnesses for the rest of the ends. The heddle system will be used later to create the Threading Cross.

Now thread the end through the front Pivoting Reed. Here you have a choice of using an eight dent or ten dent reed. Pick the one that can be sleyed evenly and as close to the desired section width as possible. If you cannot get the exact width of the section, sley your reed slightly wider. This will make it just slightly wider than the space between the hoops. The section will be narrowed down by pivoting the Reed. Never sley the reed narrower than the section on the Beam because it is critical that the ends wind on evenly across the width of each section. If the ends are set too narrow at the Pivoting Reed, there is no way to expand it.

After the Tension Box is completely threaded, move the larger Pegs downward and tighten their wing nuts securely, to apply tension to the yarns. The further down the Pegs are moved, the more tension will be applied to the yarn. This is an adjustable system as different yarns require more or less tension. With a heavy wool, the Pegs may only need to be moved half-way down, whereas with a fine silk, the Pegs may need to be moved all the way down and the yarn wrapped an extra time around one of the stationary Pegs to get the proper tension. Once you have adjusted the tension correctly, do not change it during the winding of the Beam, as long as you are using the same type of yarn.

Once the Tension Box has been threaded, it is not always necessary to rethread it. If you need to change spools or cones, simply tie the new ends on to the old ends just before the rear stationary reed and pull gently on the old ends until the new ends have come all the way through the box.

Winding The Warp

Tie an overhand knot near the end of the warp threads from one section and slip that knot into the opening of the larkshead knot you create in the Extension Cord. Pull it tight.

Line up the Tension Box to the section you will be winding.

Adjusting The Size Of The Section

Now, slowly wind about one revolution onto the Beam. As you wind, you will need to fine-tune the placement of the Tension Box along the track. When it is centered properly, tighten down the wing nuts under the Tension Box. At this point, you can pivot the "pivoting reed section" so that the yarn comes

close to, but doesn't quite touch, either the hoop to the left or the hoop to the right. Now tighten the wing nut under the pivoting reed. This shouldn't need to be readjusted unless you are using a different yarn size in another section.

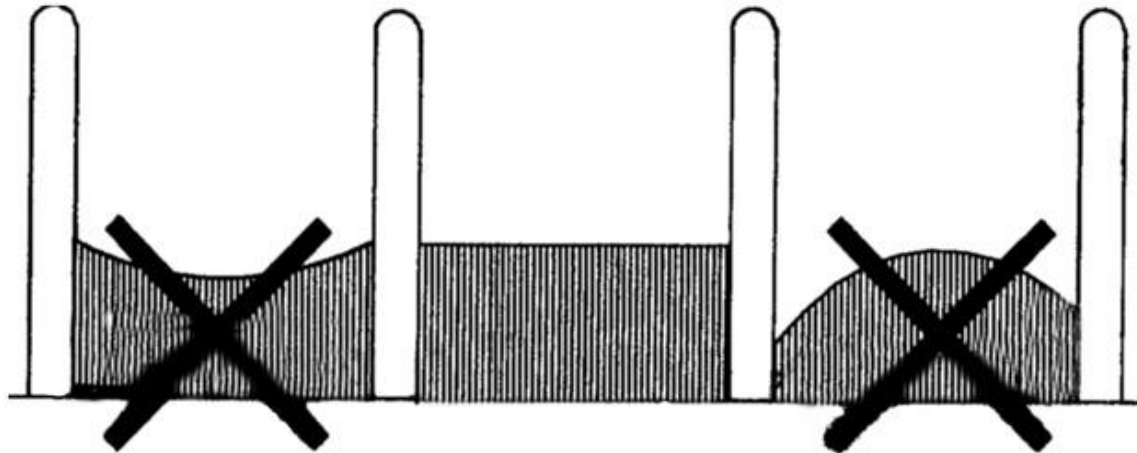

Figure 90 - Adjusting the Size of the Section

Extra care to correctly center and adjust the width of each warp section will result in more perfect tension while weaving.

Make sure that the threads are going on to the Beam in flat layers. If you notice that warp piles up at the hoops, the section of the warp is too wide. If the warp falls down at the hoops, the warp section is too narrow.

If any of the above is happening, gently unwind the warp (into a box, perhaps) and pivot the front reed on the Tension Box again until you get perfectly flat layers. This is very **important**, otherwise you will end up having different length threads in one section, since the circumference of the Beam within the section is not going to grow evenly. This uneven tension will cause tension problems.

Counting Turns Or Yardage

To determine the length of the warp you are putting on the Beam, you need to count either turns, revolutions, or yards.

To count turns, you can do it in your head, but it is more reliable to use a digital or mechanical revolution counter.

Counting revolutions even with a digital counter will only give the approximate warp length, because the circumference of the Beam will increase slightly with each rotation. This is called "Beam Build Up".

To count yards with a Yardage Counter while warping the Sectional Beam, you need to place the Yardage Counter at the front of the Tension Box. You should use an extra thread for measuring yardage, because if you use one of the threads from your warp section, that particular thread would have a different tension once you start weaving. The extra thread you use for measuring purposes can then be reused for each section.

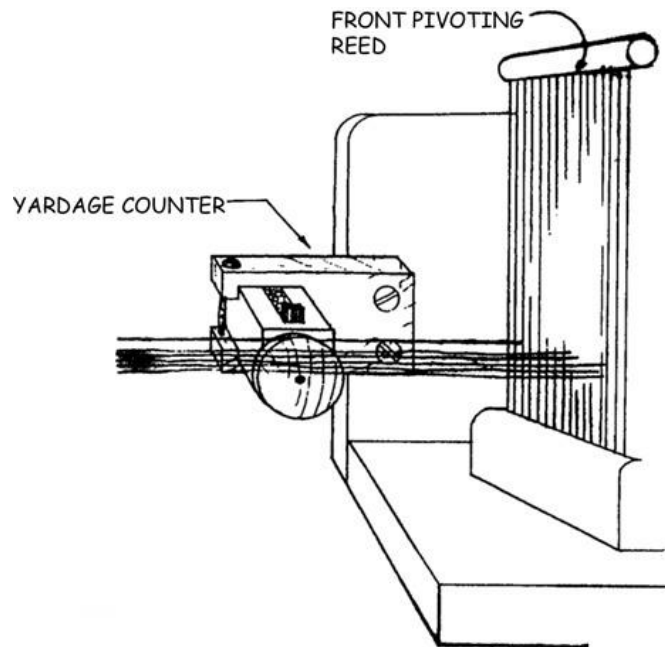

Figure 91 - Attaching Yardage Counter to Tension Box

Creating The Cross

When there is about a half-yard left to be wound onto the Beam, it is time to make the Threading Cross. Simply push on the rear Heddle Frame of the Tension Box, making half of the threads go up and the other half go down.

Now slip in an 8" piece of contrasting thread through the opening (called a Shed) created between the threads above and the threads below. Position this Marking Thread about halfway between the Tension Box and the Separation Beam (AKA the Breast Beam).

Now push down on the front Heddle Frame, making the other half of the threads go up. You may need to give a gentle tug to the section, behind the Box, to help the threads separate into the new Shed. Now take one end of your Marking Thread and bring it through this Shed. The two ends of the Marking Thread should now be together. Tying them in a bowknot, you have just made the Cross. Continue to wind the first section on, until the Cross is

nearly on the Beam. Cut the ends, and secure to the section using a piece of masking tape.

Continue winding all the sections in the same manner by moving the Tension Box along its track.

Remove the Tension Box from its track in the Back Beam and flip the Beam over.

Replace the Separation Beam into its former position atop the front verticals, with the groove facing down, to serve you as the Breast Beam.

Inserting Sticks In The Threading Cross

When all the winding is complete, remove the tape, unwind a few feet of warp from each section, and slip one lease stick through the path created at one side of each Marking Tie. Now slip another lease stick through the path created by the other side of each Marking Tie. Secure the lease sticks together, leaving about two inches between them, using masking tape or string through the end holes of the lease sticks. Now bring the lease sticks, with the warp ends, around the outside of the loom and over the Back Beam, so that warp travels towards the center of the loom (harnesses).

Readjusting The Tension

Now tie the lease sticks on the side of the loom so that they are at eye level when you are in your threading position.

To keep the warp from slipping forward during the threading process, retighten the tension rope around the pulley and tension drum and clip the rope end to the spring.

Use of Warping Wheel

The Setup

- 1) Adjust height so position of mini-raddle is just below eye level.
- 2) Adjust the wind-off tension with toggle and cord. Tie cord to prevent slipping.

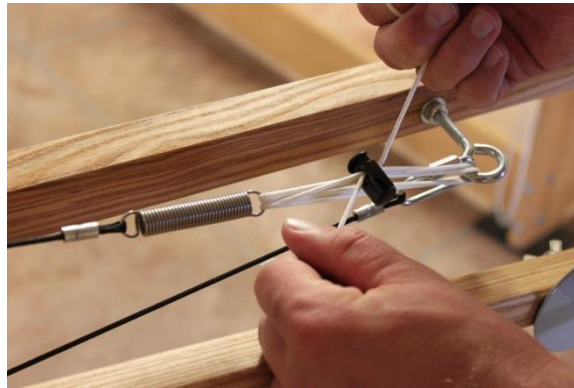

Figure 92 - Adjust Wind-off Tension

- 3) Adjust Warp Length using different spool placement by moving the spools on the arms.
- 4) Reset the Revolution Counter to Zero
- 5) Setup Cones with the Cone Caddy

Making the First Section

- 6) Open and secure the raddle top using the removable pin.
- 7) Slide the thread(s) under the metal catch clip, tails facing to the left. Tails should be about 5 inches long.

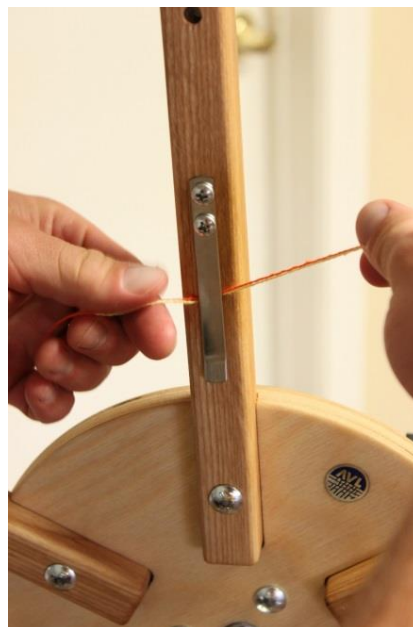

Figure 93 - Catch Thread Ends

- 8) Bring the thread(s) up and over the left side of the top spool so that you are ready to wind the Warping Wheel in a counterclockwise motion.



Figure 94 - Wind Counter Clockwise

- 9) After you have wound one length bring the thread(s) around the back of the raddle and through a dent (working from right to left).

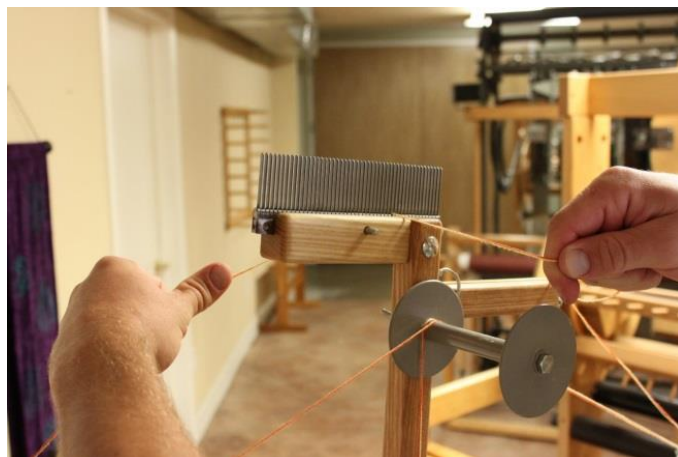

Figure 95 - Bring Thread Through Raddle

- 10) Bring thread(s) down over the end you just wound and secure in the silver clip (swooping under from left to right).

Tying Off

- 11) Put the raddle top back on. Cut the bout threads just to the left of the clip and under the threads going over the wheel.
- 12) Hold onto the threads securely at the raddle (so they don't slip through). Below, wrap the cut threads around the clip.



Figure 96 - Hold Threads at Raddle

- 13) With the raddle top secure, remove the pin from the raddle holder while holding onto the threads.



Figure 97 - Remove Raddle from Top Position

- 14) Bring the raddle down to the winding-on position and secure with the pin. Tie a knot in the thread past the raddle so it won't slip through.



Figure 98 - Place Raddle in Lower Position

- 15) Take the extension cord from your beam. Create a larks head loop at its end and loop it around the knotted end of your warp section.



Figure 99 - Place Extension Cord Around Thread Bundle

- 16) Before the last part of the threads pass through the raddle, tape the threads on the loom-side of the raddle in their sequence using masking tape. This will help you keep the threads in order when you thread the harness.
- 17) As you wind on, pivot the raddle to adjust the width of the section to fit exactly in-between the pegs on your sectional beam.



Figure 100 - Pivot Raddle

COMBINING SECTIONAL AND PLAIN WARPING

Depending on your equipment and preferences, you may prefer to wind separate warp sections on a warping board or reel and go from there directly to the Sectional Beam. If you decide to do this, however, your warp will be limited in length by what will fit on the warping board or reel. If you choose this method, follow these steps:

- 1) Calculate the number of threads for each section on your Sectional Beam.
- 2) On the Warping Board or reel, make "baby warps" for each section on your Beam.
- 3) Make crosses at each end: raddle cross on one side and thread-by-thread cross on the other.
- 4) Take the warp off the board or reel by taking off the thread-by-thread cross first.
- 5) Put the warp threads from a first "baby" warp in the Raddle, making sure that threads are spread evenly and that they are creating flat layers when wound on the Beam. Put the raddle top on or secure warp threads with rubber bands.
- 6) Instead of a regular raddle, you can put a mini-raddle in place of the front reed on the Tension Box. In this case, the Tension Box is used only for guiding threads into the sections. It is not necessary to sley threads in the Tension Box, either through the harnesses or through the back reed, and you do not need to adjust tension with the Pegs.

- 7) Attach each baby warp to the Extension Cords and proceed as in regular Sectional Beaming procedure.
- 8) Since you are not using the Tension Box for tension, be sure to keep it taut manually.
- 9) When you come close to the end of the section, take the reed cover off and continue winding the rest of the baby warp.
- 10) Secure that section to the Beam and continue to the next one.

If you wish to use the Tension Box to maintain tension on your warp during the Wind-On phase, it will be necessary to make a Cross at both ends of your warp. If you can make your warp slightly longer, you can use the extra length to leave in your Tension Box for the purpose of tying on the subsequent sections.

THREADING, SLEYING, & TYING ON

Preparation For Threading

The K-series loom was designed so that you can get as close to the harnesses for threading as possible. To do this, follow these steps.

- 1) Remove the cover over the cloth beam.
- 2) Remove the cloth beam.
- 3) Remove the guide rollers.
- 4) Remove the Beater by lifting it out of the loom.
- 5) Remove the cloth storage beam.
- 6) Place your chair or bench in a comfortable position near to the harnesses. You will have to position it over the treadles.

The important thing in threading is your comfort. Take the time to position everything so that your body feels at ease while threading.

Threading The Harnesses

The heddle support rods are held in the loom at the ends and in the middle with a hook. The hook will prevent you from moving heddles from one side

to the other. Arrange your heddles so that you have the number you need on each side before you begin threading the loom.

Now we're ready to thread the loom. If you are right handed, it is recommended to start at the right side of the warp. Grasp one group of ends in your left hand and your sley hook in your right hand. Direct the "hook end" of the sley hook through the "eye" of the first heddle you need to thread. Pull the thread through.

For example, if you had a straight draft on eight harnesses, your first thread would go through the eye of a heddle on the 8th harness. The second thread would be threaded through the eye of the first heddle on the 7th harness, the third thread through the first on the 6th harness, and so on.

Some weavers mark the center heddle on each harness and thread from center, out to each side. This allows for leaving an equal number of heddles at both sides of the harnesses, when threading is completed.

Unused Heddles

After threading is complete, make sure that the unused heddles are all pushed to the far sides of the harnesses. For balance, there should be approximately equal numbers of unused heddles on both sides of each harness.

Note:

In the first six months of using a new loom with polyester heddles, the heddles may stretch out slightly to adjust to the harnesses.

Sleying The Reed

Replace the cloth storage beam and the beater on the loom. Now sley the warp ends through the reed. Some weavers start from the right side; some from the left; some in the middle. But, in all cases, be sure to measure accurately before starting so that the warp will be centered in the reed (or offset if the warp on the beam is already offset). Use the way you prefer to position and stabilize the reed between the harnesses and the Breast Beam for ease during the sleying process.

Tying On To The Apron

Replace the guide rollers and the cloth beam. Now that you have your warp ends ready to tie, we need to prepare the apron. The ends will be tied to the apron rod.

Now tie the ends to the metal rod. Starting from the middle, bring a first bundle toward you over the apron rod, then around and under it. Divide it in half and bring one half up on each side of the bundle. Use the ends to tie a surgeon's knot. It is the same as the first tie you make tying a shoelace, except you loop the end through twice. This kind of knot is very good for hold and readjusting the tension.

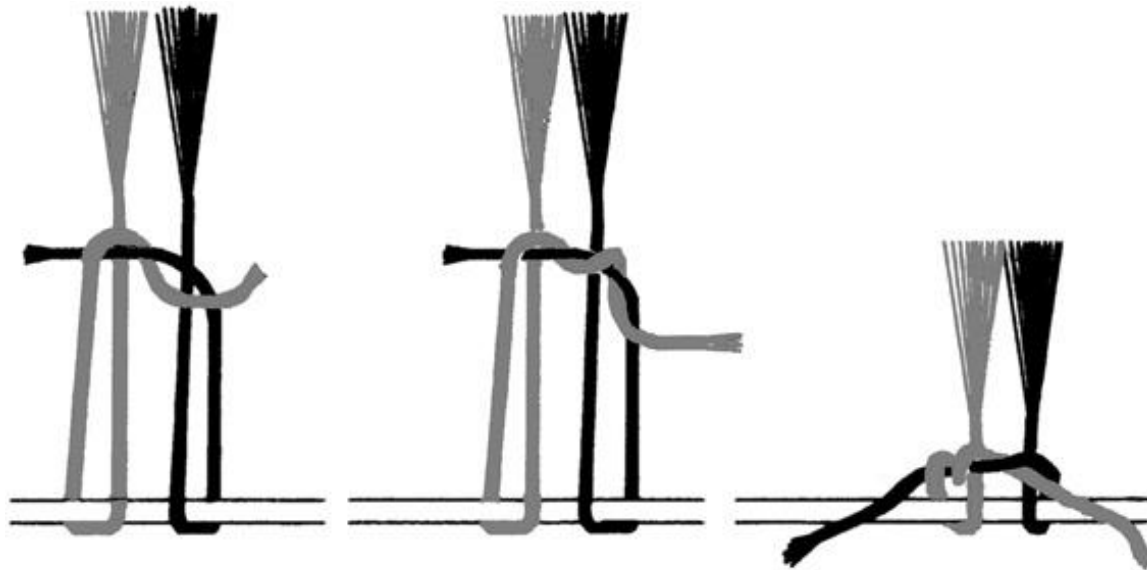

Figure 102 - Surgeon's Knot

Start with one section in the middle, then the far right and the far left outside ones. Work your way in. After tying the knot, pull only until you feel some resistance and tighten the knot and proceed to the next section.

By now, the sections that were tied first maybe quite a bit looser than the ones tied last. To correct this, you do not need to untie the knots, simply grasp the ends and pull them away from you, then re-tighten the knots, remembering to only pull until you feel, what is now, a uniform resistance at each group. Repeat this until all of the sections are at approximately the same tension. It is important to remember at this point, that you are not trying to achieve weaving tension, only *uniform* tension across the width of your warp.

As directed in the preceding warping instructions, you'll secure the front of your warp to the Cloth Storage Beam via the apron.

Tying On To An Old Warp

A new warp can be tied on to an old warp, thus eliminating the threading and sleying process, if the new warp introduced into the loom uses the same threading pattern and E.P.I. as the last warp. This process is especially good for production weavers as it saves time. It also takes less concentration and there is less chance of making mistakes in threading.

The tying on process starts when you are finishing the last warp on the loom. Before you cut off the fabric from the old warp, make sure to leave enough unwoven warp to extend one foot behind the harnesses, through the heddles, and about six inches past the reed when the beater is in its rear position. Now open two opposite tabby sheds and insert the lease sticks into these sheds behind the harnesses. Secure the sticks together with tie tapes through the holes.

Now carefully cut the fabric from the loom and tie bundles of warp coming through the reed together with a half-knot so the yarn can't slip back through the reed. Cut the warp in back (leaving one foot past the lease sticks) and also use a half-knot to tie bundles of yarn together for security.

After winding on the new warp on the Beam, you can sit behind the loom, on a small stool and tie corresponding yarns from the two sets of lease sticks together. An overhand or weaver's knot work well. This may seem slow at first, but you will work up a faster rhythm with some practice. A good goal to reach would be to tie 200 to 250 ends together an hour.

When all ends are tied together, go to the front of the loom and gently pull on the bundles of yarn going through the reed to pull the new warp through the heddles and reed. You may find that turning small bundles of the warp in a circular, clockwise motion will help them through the heddles and reed. Then tie on to the apron.

SETTING THE TENSION

Note:

Full information on using the weaving software for the K-series loom is included in the CD5 manual.

You can set the tension by entering a number in the field or by using the up and down arrows on the field. The default tension is set at 55.

- 1) In the software go to the Warp Tension field. Use the arrow keys to change the value, or click in the field and type in the value you want.

TO REMOVE OR TO CHANGE THE REED

- 1) Loosen the bolts on the top and bottom supports to the reed.



Figure 103 – Loosen bolts

- 2) Slide the bottom support down slightly.



Figure 104 – Push down bottom support

- 3) Slide the reed out to the side.



Figure 105 – Push the reed out

- 4) Slide the new reed in.



Figure 106 – New reed inserted

- 5) Make sure the reed is centered.



Figure 107 – Center reed

- 6) Make sure the top of the top support is even with the top of the bracket.



Figure 108 – Even top and bracket

- 7) Tighten the bolts on the top support.
- 8) Slide the bottom support back into position.
- 9) Tighten the bolts on the bottom support.

USING THE BEATER

The AVL loom's beater is designed to increase weaving speed. It has a light and easy action and little physical exertion is needed to operate it. Weaving can be done for hours without tiring the weaver. With a properly wound bobbin and a little practice of the throwing technique, selvage edges turn out smooth and even.

USING THE AUTOMATIC CLOTH ADVANCE

The auto advance controls allow you to advance the warp without weaving, or reverse the warp. You can also set the picks per inch. The default PPI is 15.

- 1) In the software go to the PPI field.
- 2) Use the arrow keys to change the value, or click in the field and type in the value you want.

Reversing the Warp

- 1) If you need to unweave, take the pin out of the cloth advance so that the cloth will unwind. You will need to reset the tension when you are done unweaving.

WARNING:

If you do not remove the pin out of the cloth advance before unweaving, you risk damaging your loom.

USING THE CLOTH STORAGE ROLLER

When weaving long lengths of fabric, the material is taken around the front cloth beam and passed to the cloth storage roller which can accommodate a roll up to 16" in diameter. The cloth storage system is designed to automatically wind the woven cloth onto the storage roller as the cloth is advanced. A looser tension is maintained on the storage roller than on the weaving. This eliminates any strain on the fabric while the special abrasive surface of the cloth beam holds the proper tension on the weaving being done. This also makes it possible to weave long lengths of fabric that have an uneven surface which would ordinarily cause poor tension because of the uneven build up on the cloth beam.

You should have already tied the ends of your warp onto the metal rod in the apron. If so, as you weave, your fabric will automatically be wound onto the cloth storage roller. The cloth storage beam is advanced by the beater and should need very little attention from you.

USING THE RING TEMPLES

The Temple System is used to maintain a good selvage and prevent draw-in. You'll usually deploy it after you've woven-off some fabric, once you have selvage enough to work with. It consists of two rollers(barrels), one on each side of the fabric, which grab the selvage and prevent it from drawing in.

- 1) Your fabric should rest on top of the guide and come near the end of the temple mount bracket.
- 2) Once this is in place, it's time to put on the ring temples.
- 3) Make sure to have one washer on the rod, place the rod through the slot of the mount bracket. This slot gives you the choice of how much tension is needed depending on the type of fabric you're weaving.
- 4) Now put on another washer and then the nut.
- 5) Leave a little loose and mount the other side following the same procedure.
- 6) Once both sides are in place, you're ready to adjust to the perfect tension.



Figure 109 - Ring Temple on Fabric

- 7) Press down on the ring temple until you're comfortable with the tension and tighten the nut securely.
- 8) Now adjust the other side in the same way.

- 9) When all is set, take a quick look (and feel) and make sure everything is very tight. This is very important in order to not have it loosen later.

Using a temple system is somewhat of an art and opinion varies amongst weavers about things like the choice of rings. In fact, there are many rings to choose from -- some with large spikes, some with shorter. Call AVL for details.

REMOVING THE CLOTH FROM THE LOOM

After you've completed your weaving, use the following procedure for removing the cloth from your loom:

- 1) Cut your cloth off where desired and lift it off the cloth beam.
- 2) Manually wind the excess cloth onto the storage roller.
- 3) Remove the cloth storage beam from the loom. Lift the right side of the roller up and toward you until it disengages with the tube end on the left.
- 4) Once the beam is off the loom, take the cloth off the roller.
- 5) Replace the empty cloth storage roller in the loom.

ADDITIONAL LOOM INFORMATION

LOOM MAINTENANCE

Tightening the Bolts

The single most important thing you can do to extend the life of your loom, and preserve its operation, is tighten the bolts that hold its frame together. These will loosen over time, due to changes in its environment and to your own creative exertions.

Lubrication and Cleaning

There are several mechanisms on your loom which will benefit from the occasional light application of an appropriate lubricant. Everything has been lubricated before leaving the factory; however they will require new applications of lubricant at regular intervals. In general, parts should be lubricated after 160 hours of weaving. Since this will vary depending on the weaver, consider putting a note on your calendar at the approximate date when you will have completed that much weaving.

Not all lubricants are suitable in the weaving environment. Machine oils and greases, for example, can capture yarn dust and will, over time, actually impede the action of your loom. Some of the parts on your loom require a dry film lubricant, such as RZ-50. This comes in a spray can which will allow you to direct the lubricant to a specific area. A few parts require the use of clear synthetic grease such as Tri-Flow Clear Synthetic Grease (TF23004). Pay attention to the directions below regarding which lubricant to use and where to direct it.

Dobby Bearing Slides

There are two sections on the Dobby that will require dry film lubrication: the bearing slides and the thrust bearings at the end of each arm. This should be done after every 160 hours of weaving. The harnesses should lift smoothly and quietly if lubrication is applied regularly. If there are squeaks or grinding noises coming from the Dobby, lubricate these parts.

Note:

The following pictures have had some of the cables and electronics on the Dobby removed in order to focus on the parts that need lubrication. When lubricating your Dobby, do not remove anything, just reach under the cables and electronics to reach the parts shown in these pictures.

- 1) Remove the Dobby cover. You will need to reach under the doobby cables to reach the parts that need lubrication. Aim the spray

carefully so that only the specific places shown below are lubricated.

- 2) There are two bearing slides on each side of the loom. This picture shows one side.
- 3) The bearings are small round balls on which the slides are able to move smoothly and quickly. On each slide, look for the bearings and spray dry lubrication from the top directly onto the bearings.

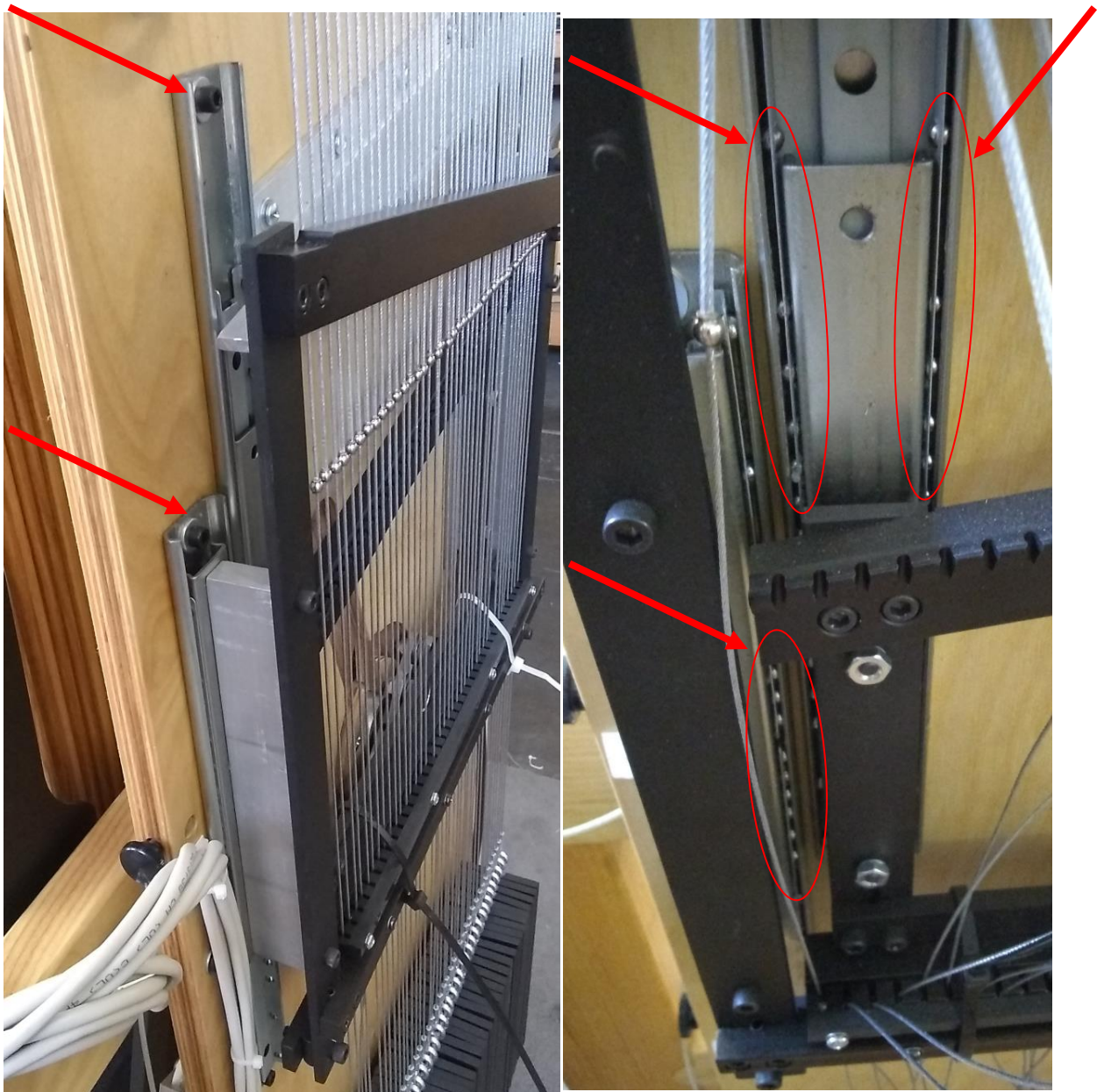

Dobby Arms

In the center of the dobbie are dobbie arms which rotate in and out. At the end of each arm is a blue thrust bearing that will require lubrication.

- 1) Locate the blue thrust bearings. It is easy to see two of them from the top when the dobbie arm is closed.



- 2) Open the dobbie arm by pressing the bottom slide plate down to locate the other two thrust bearings. The following picture shows one arm at the bottom.

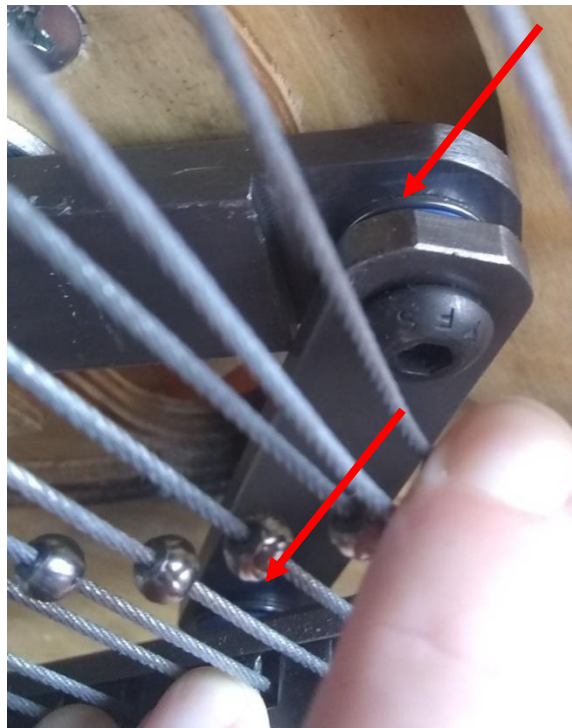

- 3) Spray each of the four thrust bearings.

Dobby Lint Cover

You should also check the lint cover on the dobbie occasionally to make sure it is not plugged up. If it is, use a handheld vacuum or the brush attachment on a larger vacuum to clean it off.



Power Box

The power box has two lint covers, one for air intake and one for outtake. Check to make sure the air intake cover is not plugged up. If it is, use a handheld vacuum or the brush attachment on a larger vacuum to clean it off.



Cloth Storage Beam Bearing

The cloth storage beam is advanced with a clutch bearing on one side of the loom.

- 1) On each side of this bearing you will see a small plastic gear with bearings underneath it.
- 2) Spray each side with dry film lubrication.



Cloth Advance Gears

There is a worm gear on the cloth advance that should be coated with a light coat of clear synthetic grease after every 160 hours of weaving.

- 1) Remove the sandpaper beam cover and the sandpaper beam from the loom.
- 2) Put some light globs of grease on the grooves on the front of the gear.

Note:

As you use the loom, the grease will be distributed over the gear.



- 3) Replace the sandpaper beam and the sandpaper beam cover.

Tension Motor

The tension motor uses a screw to move up and down; changing the tension on your loom. This screw should receive a light coat of clear synthetic grease every six months.

- 1) Using AVL Drive, push the button to free your warp beam. This will put the screw at the top-most position.
- 2) Put a small glob of the clear synthetic grease on the screw where there has been grease on the screw before.

Note:

You will see a color change between the gray screw and the section that has been blackened with grease.

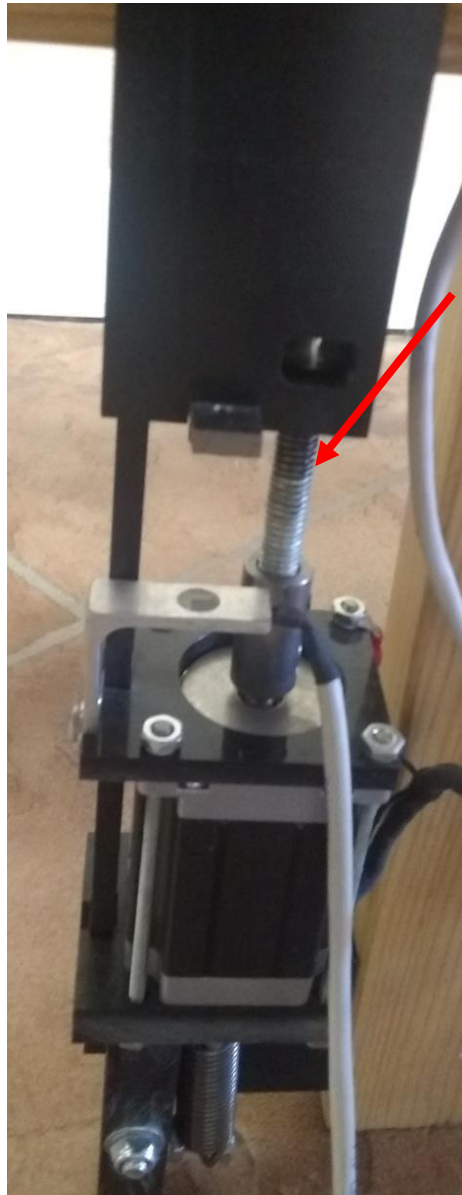

- 3) In AVL Drive, push the button to lock the warp beam. This will move the screw to the bottom-most position, spreading the grease as it moves.

Pulleys

The pulleys on your loom should not need lubrication. However, if any of the pulleys are squeaky, spray them with dry film lubrication or silicon spray.

Shuttles and Shuttle Race

If you notice any trouble with the movement of your shuttles, use paste wax on your shuttles and shuttle race.

Checking Cables

The cables on your loom will wear out eventually due to the friction of the moving parts. Check all cables for wear and replace as needed.

Brake Cable

Note:

The K-series loom is designed so that you do not need to unhook the brake cable in order to warp the loom.

If you remove the Brake Cable, please be sure, when you reinstall it, that the looped end is secured to the "J" bolt, that the cable is drawn immediately up from this bolt and around the back of the drum (x3), and that it then routes down the front of the drum where it connects to the spring at the pedal. Be sure the cable does not cross over itself at any time.

Tool Kit And Spare Parts

Here's a list of the basics, nice-to-have-around items:

- 1) Minimum Tools
 - Socket Wrench with
 - 7/16", 1/2" sockets
 - Crescent Wrench
 - Large Standard Blade Screwdriver
 - Small Standard Blade Screwdriver
 - Phillips Screwdriver
 - 1/8" Allen Wrench
 - Level
 - Paste Wax
 - 0000 Steel Wool Pad
 - 220# Sandpaper
 - Dry Film Lubricant

[] Clear Synthetic Grease

2) Spare Parts You Might Consider Having

[] Spare Treadle Cable (left/right)

TROUBLESHOOTING

Harness Issues

Symptom	Possible Cause	How to Fix it
Harnesses don't raise properly.	1.) Harness cables have been hooked to the wrong harness.	Reattach the cables to the correct harnesses.
	2.) Bottom cables have been hooked to the wrong harnesses.	Reattach the cables to the correct harnesses.

Tension

Symptom	Possible Cause	How to Fix It
A) Your Warp Beam won't hold tension.	1) You have mis-routed your brake cable. If you have just installed the system, or disconnected your Brake Cable to move the loom, you may very well have incorrectly replaced it.	Review the cable routing as shown in the Assembly Section.
	2) You may have warped your beam backwards. Consult the Weaving Section which illustrates how your warp should be routed.	If you did warp your beam backwards, you will need to remove the warp and start over.
	3) The sandpaper on your Cloth Beam is not grabbing the warp and pulling it around as it should	You'll very likely need to add SoftGrip or another kind of beam cover in order to get satisfactory warp tension.
B) Your warp tension is different in different places over the width of the warp.	1) It is not indicative of a tensioning problem. It is a matter of not having maintained even tension when warping the beam and there's no redress from the Tension System. It's just too late for this warp to be well tensioned.	You should have used a Warping Wheel for sectional warping or craft paper for plain beam warping. If you do not want to waste this warp, place something (folded paper or cloth) in the areas on the beam where your tension is looser. You will have to move your paper every time you advance the warp and also keep adding more since it will probably become looser and looser.

Symptom	Possible Cause	How to Fix It
C) Excessive tension on the warp.	2) The tension cable has gotten crossed over itself on the warp beam brake drum.	Straighten out the cable.
D) Cloth is not wrapping around the cloth storage beam correctly.	1) The clutch controlling the cloth storage beam may need tightened.	Tighten the bolt on the cloth storage beam. See page 45.

The Shed

AVLs are designed with a shed which exactly meets the need; not too wide, not too narrow. And there is, of course, a reason for this precision. Raising harnesses higher than you need may give you a larger shed, but it's also a waste of time and effort. You only need enough warp separation for the shuttle to pass freely. However, because the shed on AVLs is so precisely calibrated, you do need to be sure that you're getting all that the loom can deliver.

Symptom	Possible Cause	How to Fix It
A) Restricted Sheds.	1) Treadle cables fell off the pulleys.	Replace the treadle cables so they go over the pulleys.

Beaters

Symptom	Possible Cause	How to Fix It
B) One side of your fabric is beaten more tightly than the other, even if you are holding your beater in the middle. You have a diagonal beat line rather than horizontal.	1) Your beater is out of alignment.	To check, push your beater all the way back against the Beater Bumper Blocks, it should strike both sides at exactly the same time. If it doesn't, you'll need to adjust the bolts holding the beater to the loom.

Cloth Storage Beam

Symptom	Possible Cause	How to Fix It
A) Cloth is not wrapping around the cloth storage beam correctly.	1) The clutch controlling the cloth storage beam may need tightened.	Tighten the bolt on the cloth storage beam clutch. See page 45.

Dobby

Symptom	Possible Cause	How to Fix It
A) Dobby skips.	1) Pressing too hard or too quickly on the treadles.	Press the treadles with a smooth, rhythmical motion.

REFERENCE GUIDE

- 1) Connect your computer, phone, or tablet to your loom. Open a browser and go to [http://\[loom name\].local](http://[loom name].local).
- 2) Power the loom on in the software.
- 3) Click the warp tension button to set the tension for winding on. You will not need to remove the brake cable on the warp beam.
- 4) Warp the beam.
- 5) Thread the heddles. To get as close as possible to the heddles, remove the cloth beam cover, the cloth beam, the cloth guide rollers, the beater, and the cloth storage beam.
- 6) Replace the cloth storage beam and the beater.
- 7) Sley the reed.
- 8) Replace the cloth guide rollers, cloth beam, and cover.
- 9) Attach the warp to cloth storage apron.
- 10) Set the desired warp tension in the loom software. The default is 55.
- 11) Advance the warp for weaving. If you set the PPI in the software to 1, you will be able to advance rapidly.
- 12) Set the PPI to the setting you want to weave with.
- 13) Open the WIF you want to weave in the loom software.
- 14) Weave your project.
- 15) When you are done with a weaving session on the project, you can power off the loom in the loom software.
- 16) When you are ready to start again, power the loom on in the loom software, open the WIF you are using and double-check the settings before beginning to weave again.
- 17) When your project is complete, remove the cloth from the loom.

THE FINE PRINT

AVL CUSTOMER SERVICE

AVL offers free technical support to the original owner of all our looms. This means if you ever have a problem, you can call, fax, or e-mail us and we'll help you find a solution. Please take advantage of this service; your satisfaction is extremely important to us.

Customer Service Phone: (530 893-4915)

Fax: (530) 893-1372

E-Mail: sales@avlusa.com

AVL WARRANTIES

Limited Warranty: The benefits of this warranty accrue solely to the original purchaser of AVL Looms, Inc. products, as defined below.

Your warranty covers:

New Looms: AVL Looms, Inc., a California corporation ("AVL") warrants to the original purchaser of any AVL loom (each, a "Product") that the Product will be free from defects in materials and workmanship during the limited warranty period described herein. The limited warranty coverage begins (a) the day the Product is installed if installed by a professional from AVL, or (b) on the date of shipment from AVL to the original purchaser if the Product is not installed by AVL (the "Effective Date"). Except as set forth under the section entitled "What is Excluded?" below, AVL will, for a period of two (2) years from the Effective Date (the "Original Warranty Period"), repair or replace the defective part(s) of the Product with a repaired, renewed, or comparable part (whichever is deemed necessary or proper by AVL) if it becomes defective or inoperative or fails to perform according to AVL's specifications. Any repair during the Original Warranty Period will be carried out without charge to you for parts (except applicable taxes, if any). You will be responsible for all labor in connection with installation of the parts and service upon the Product, as well as the cost of shipping involved.

New Accessories, Loom Upgrade Parts, and Replacement Parts: Subject to the limitation contained in subsection (i) under the section entitled "What is Excluded?" below, AVL warrants to the original purchaser of any accessory, loom upgrade parts, or loom replacement parts (the "Additional Part") that are sold by AVL that such Additional Part will be free from defects in materials and workmanship for ninety (90) days from the date of purchase. In the event that any Additional Part is physically damaged or physically defective and if such defective Additional Part is returned to AVL within ninety (90) days of the date of purchase, AVL will provide a replacement Additional Part at no charge. The sole remedy for this warranty shall be limited to the replacement of the defective Additional Part. You are responsible for all shipping charges (including applicable taxes) incurred with returning the defective Additional Part.

All New Products and their components (including replacement Product and its components) are covered only for the Original Warranty Period. When the warranty on the original Product expires, the warranty on any replacement Product, or components also expires. After two (2) years from the Effective Date, you pay for any replacement or repair, including all parts, all labor and shipping charges (including applicable taxes).

Your warranty does not cover:

1. Labor charges for installation or set-up of the Product, as well as any labor charges required to install, disassemble, troubleshoot, or reassemble the Product.
2. Any taxes imposed on AVL for Product replacement or repair under this warranty.
3. Installation, performance of, or repair of: cabling, electrical, or accessory attachments used with the Product.
4. Product replacement or repair because of misuse, accident, repair by any party other than AVL, or other cause not within the control of AVL. Please note that removing any parts from the Product for any reason voids the warranty.
5. Incidental or consequential damages resulting from the Product.
6. A Product that has been modified or adapted to enable it to operate in any country other than the United States or any repair of Products damaged by these modifications.
7. Electrical and pneumatic components, each of which carries a one (1) year warranty from the Effective Date.
8. Jacquard components function beyond 98%. A Jacquard module is considered to be operating within specification if 98% of all hooks are operating as commanded.
9. Computing equipment, such as a Personal Digital Assistant or a Personal Computer, which are manufactured by a third party(ies) and which may be under warranty through the original manufacturer. AVL is not responsible for any warranty coverage that may be offered concerning these products and you must contact those manufacturers directly regarding any available warranty coverage.

The performance or functionality of any software that is sold either together or separate from the Product. The AVL warranty covers only defects in the Software Media, namely the CD-ROM media such as a broken CD-ROM or a defect in the CD-ROM that would prevent the CD-ROM from being read by your personal computer's CD-ROM drive. .

AVL Returns Policy

Any order that has left AVL in transit to the customer is considered fulfilled. Parts and accessories not covered under warranty must be returned to AVL within 60 days from the date of shipment from AVL. The purchase price of the item(s) is refundable less a 15% re-stocking fee based on the total purchase price. No refunds will be given on shipping or handling. The buyer is responsible to return the merchandise in "as new" condition at their expense. Any item received showing wear or damage is not eligible for return and will be promptly returned to the customer COD unless some other arrangement is made. Looms and custom-made items, special order items, parts made for pre-1998 looms, used and reconditioned items are not eligible for return.