

AVL Home Loom User Manual

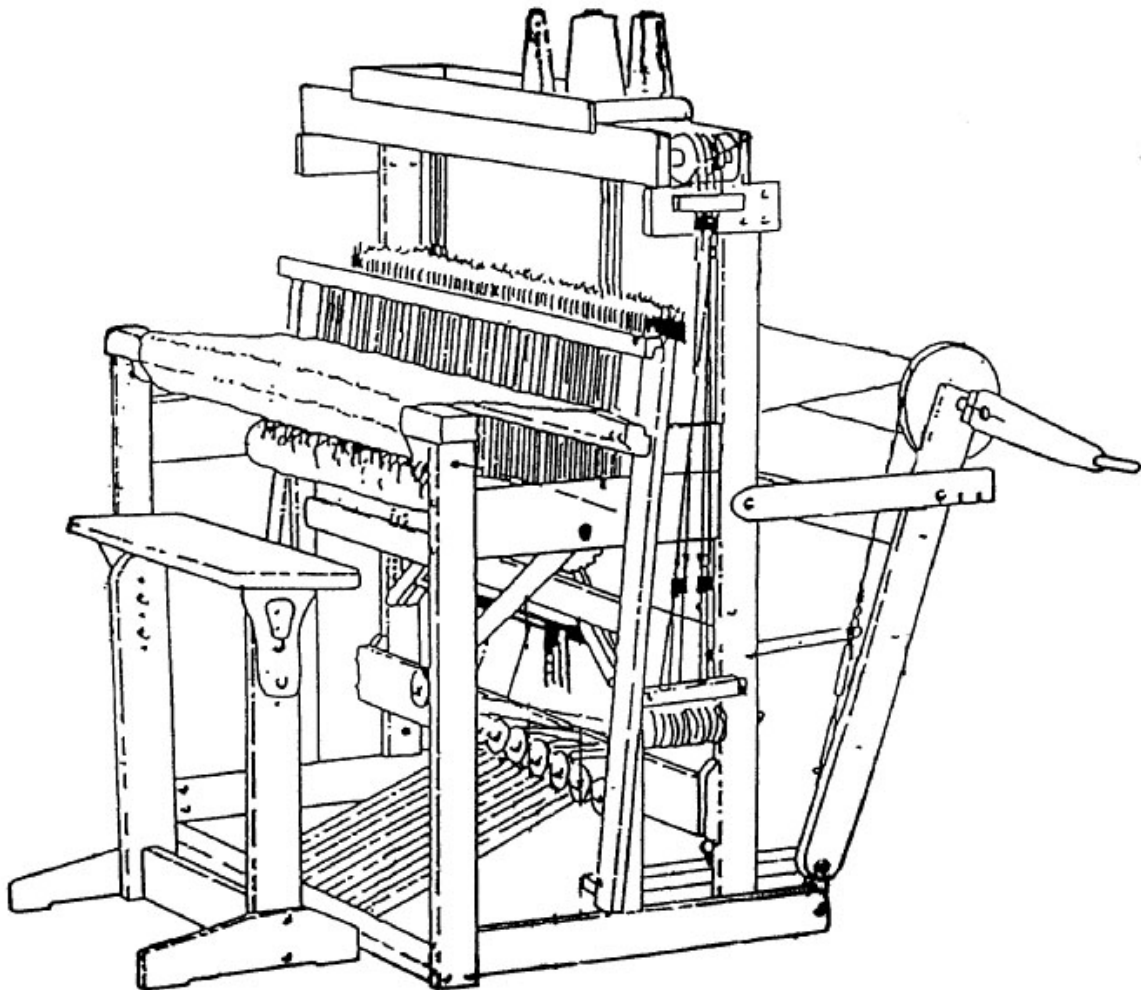

AVL Looms
2360 Park Ave.
Chico, CA 95928-8305
530 893-4915 * 530 893-1372 fax #
www.avlusa.com * sales@avlusa.com
Published 5/28/2020



Introductory Information	1
Safety	2
Introduction.....	3
Loom Features	4
Loom Assembly	7
Before You Begin	8
Inserting Nuts And Bolts	9
Connect Side Frames.....	10
Assemble Front Lower Cross Member.....	12
Front Cross Member Installation	13
Cloth Storage Beam Installation	13
Spring Lever Support	14
Treadle Cable Installation And Routing.....	15
Square and Level the Loom.....	16
Install The Harness Pulley Support Assembly	17
Harness Assembly.....	18
Spring Lever System	22
Breast Beam.....	24
Beater Assembly	25
Unfolding the Warp Beam.....	29
Warp Beam Placement	30
Attach the Brake Cable.....	32
Appendix – Optional Features	35
Tension box (Optional).....	36
Storage Shelf (Optional)	37
Flyshuttle (Optional)	37
Automatic Warp Tensioning System (Optional)	42
Second Beam System (optional).....	45
Weaving Instructions	47
Warping The Plain Beam	48
Warping The Sectional Beam.....	55
Combining Sectional And Plain Warping	70
Threading, Sleying, & Tying On	72



Harness Springs.....77

Treadle Tie-Up.....78

Weaving.....80

Additional Loom Information.....83

 Loom Maintenance.....84

 Troubleshooting87

The Fine Print89

 AVL Customer Service90

 AVL Warranties.....90

 Notice to Users in the European Union.....92



INTRODUCTORY INFORMATION

SAFETY

Before Getting Started:

Please read the entire manual before using the loom.

WARNING:

EQUIPMENT SHOULD ONLY BE USED FOR TEXTILE MANUFACTURING. IF THE EQUIPMENT IS USED IN A MANNER NOT SPECIFIED BY THE MANUFACTURER, THE PROTECTION PROVIDED BY THE EQUIPMENT MAY BE IMPAIRED.

Safety Features:

Covers and shielding separate weaver from moving components where pinch hazards exist. Do not reach under covers and shielding while the loom is operating.

INTRODUCTION

Learning to warp and weave an AVL Home Loom will be a rewarding experience for beginning and experienced weavers alike. The efficiency of the design, along with the sturdy construction and trouble-free operation will ensure your weaving time is enjoyable.

Please read both the loom set-up and weaving sections, even if you are an experienced weaver. There may be hints and tips contained on the following pages that you have not come across before.

About AVL

AVL Looms has been in the business of designing and building some of the world's finest handweaving looms since 1977.

Jim Ahrens had been building and designing looms for a number of years before Jon Violette, the "V" in AVL, approached Ahrens about a partnership in 1977. Violette, an industrial management professional, had discovered Ahrens' work through his sister who ran the Pacific Basin School of Textiles in Berkeley, where Ahrens was a volunteer advisor.

The two men worked together in the Bay Area for three years until Violette moved Ahrens and Violette Looms to Chico, where it officially became known as AVL Looms Inc., and has operated ever since.

In 1982, Violette was instrumental in the development of the first computerized dobby, then called the "Apple Dobby". He retired from active life in the company in 1987.

Once known for our production looms, AVL has broadened its line considerably and we now offer customers a full spectrum of fine weaving equipment, ranging from our Home Looms, to our Industrial Dobby Looms, Rug Looms, and Jacquards.

The Home Loom Concept

The Home Loom is AVL's marriage between the innovative technology found in our other looms and a family room friendly design. We even designed the warp beam mounting to fold up enabling easier loom storage. It features the same kiln-dried hardwood construction, nicely oiled finish, and attention to even the smallest detail found on all other AVL looms. Another inviting characteristic is the Home Loom's unique side tie-up design.

LOOM FEATURES

Brake System

The standard brake system for the Home Loom is a locking brake system. This means that the Warp Beam will not release warp until you depress the Brake Pedal. It's fairly foolproof and affords very taut warps. When your fell line has moved as far forward as desired and you wish to advance your warp, quickly depress the pedal with a short, tap-type motion and crank the warp forward with the Cloth Advance Handle. If you are using two warp beams, each will have its own brake pedal which must be depressed separately.

Automatic Warp Tensioning System (optional)

The automatic warp tensioning system is an optional feature that allows you to advance the warp without depressing the brake pedal. You will find that you can weave with less warp tension with this system than with the conventional locking brake. Once the correct tension adjustment is made, it will be maintained automatically as the weaving is advanced.

On the Home Loom automatic tension is allowed by inserting a spring into the existing brake system. This allows the warp to advance automatically when the Cloth Advance Handle is cranked, while maintaining the desired tension during weaving. The brake pedal remains in place on the loom, however it will not be used by the weaver.

Cloth Storage System

The Cloth Storage System consists of the Cloth Storage Beam (immediately in front of the weaver's knees), the Cloth Storage Apron, and the Cloth Advance Handle and pawl.

Breast Beam

The breast beam is located at the front of the loom. The cloth is routed over it to the cloth storage beam.

Swinging Beater

The Swinging Beater is a standard feature of this Loom.

Plain Beam

The Plain Beam is provided with an apron, which will allow you to maximize the length of your warp.

Sectional Beam (optional)

If you have purchased a Sectional Beam, you will find it to be extremely adaptable to your needs. Because each of its hoops is removable, you may create sections of any width you like, provided they are calculated in one-inch increments.

An AVL Sectional Beam with metal hoops has holes for the hoops at 1" sections. The wheel comes with enough metal hoops to setup 2" sections. More hoops can be ordered from AVL if narrower sections are desired. For wider sections, remove as many metal hoops as needed.

Second Beam (optional)

Additional brackets can be added to the home loom to allow a second beam to be used. Only a plain beam can be used as a second beam.

Treadles

The treadles raise and lower the harnesses. Depress a treadle to raise the attached harnesses, and release the treadle to lower them. You will attach the harnesses to a treadle using the side tie-up system.

Spring Levers

These hold the harnesses down and prevent your heddles from floating. The important thing to remember is that the system is designed so that it can be "fine tuned" for each particular warp, so experiment with it. In general, for most medium tensioned warps, you will find that adjusting will not be necessary. There is a spring lever at each end of the harness, with a chain and a spring between each set.

Harnesses

You will have either polyester or metal heddles on your loom. The supporting harnesses (or shafts) are different for the two heddle types: metal heddles, whether twisted wire or flat steel, are suspended from steel heddle bars mounted in rigid frames; polyester heddles are carried on Harness Sticks, top and bottom. In all cases, the harnesses are stabilized at the bottom by a



series of spring levers. These hold the harnesses down and prevent your heddles from floating.

Some weavers like metal heddles because they feel these are easier to thread; others prefer the lighter and quieter polyester heddles.



LOOM ASSEMBLY

BEFORE YOU BEGIN

Putting together your new loom may look intimidating at first, but this manual is designed to guide you through the process with clear steps, pictures, and diagrams. If the manual is unclear or confusing at any point, call us at 530-893-4915. We're here to help.

There is a definite advantage in assembling your own loom. You'll come to know it very well, sooner than you otherwise would, and the better you know your loom, the better you'll be able to use and maintain it.

Tools:

- Hammer
- Socket Wrench with 1/2", 7/16", and 9/16" sockets.
- Large Bladed Screwdriver
- Medium Phillips Screwdriver
- Large Phillips Screwdriver
- Scissors
- Crescent Wrench
- Occasional Extra Pair of Hands

Once you've gathered your tools, open all the boxes and lay the contents out just as you find them. Please DO NOT remove the tape or other packing materials from any of the components until we tell you. Also, leave the hardware bags unopened until they are required.

For protection in shipping, packing materials of several sorts are used around the pieces of your loom. Check the packing materials carefully for loom parts and hardware. You may want to keep all the shipping materials until the loom has been put together to make sure nothing is lost.

The boxes your loom comes in are custom made for shipping your loom. If you have space to store them, you may want to keep them for future shipping or moving. If you do not wish to breakdown and box the loom, it can be left assembled for moving, but make sure to strap down, or remove, any moving parts.

You'll need a space about 5' x 5' to assemble your loom. In addition, a conveniently located desk or table will come in very handy for several of the operations.

Depending on your particular style of work, the entire assembly operation will take between three and eight hours.

INSERTING NUTS AND BOLTS

NOTE:

Given the limited space provided by the nut access holes, it can be challenging at first getting the nuts onto the bolt ends. You'll find it helpful to push each bolt in just until it just appears in the access hole. Move the nut into position over the end of the bolt and hold it with your finger. Slowly turn the bolt clockwise and when the nut engages, tighten it most of the way down.

If your fingers are too big to comfortably manipulate the nut, try holding it with a flat blade screwdriver or needle-nose pliers.

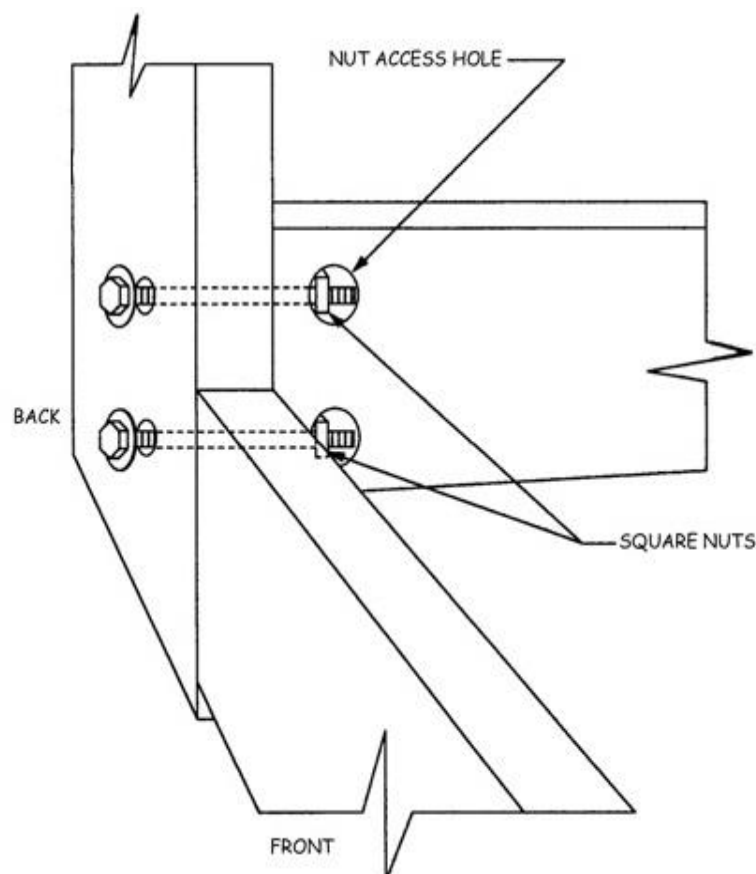

Figure 1 - Inserting Nuts

Note:

As you are building the loom, do not tighten the nuts all the way down. You

will tighten everything down once you have squared and leveled the loom as described on page 16.

CONNECT SIDE FRAMES

- 1) Find the Right and Left Side Frames. The Right Side has the pulleys and Brake Pedal already attached.

Note:

If your loom comes with an optional second beam, there will be a brake pedal on the left side as well. You can tell the frames apart by the harness pulleys attached to the right side.

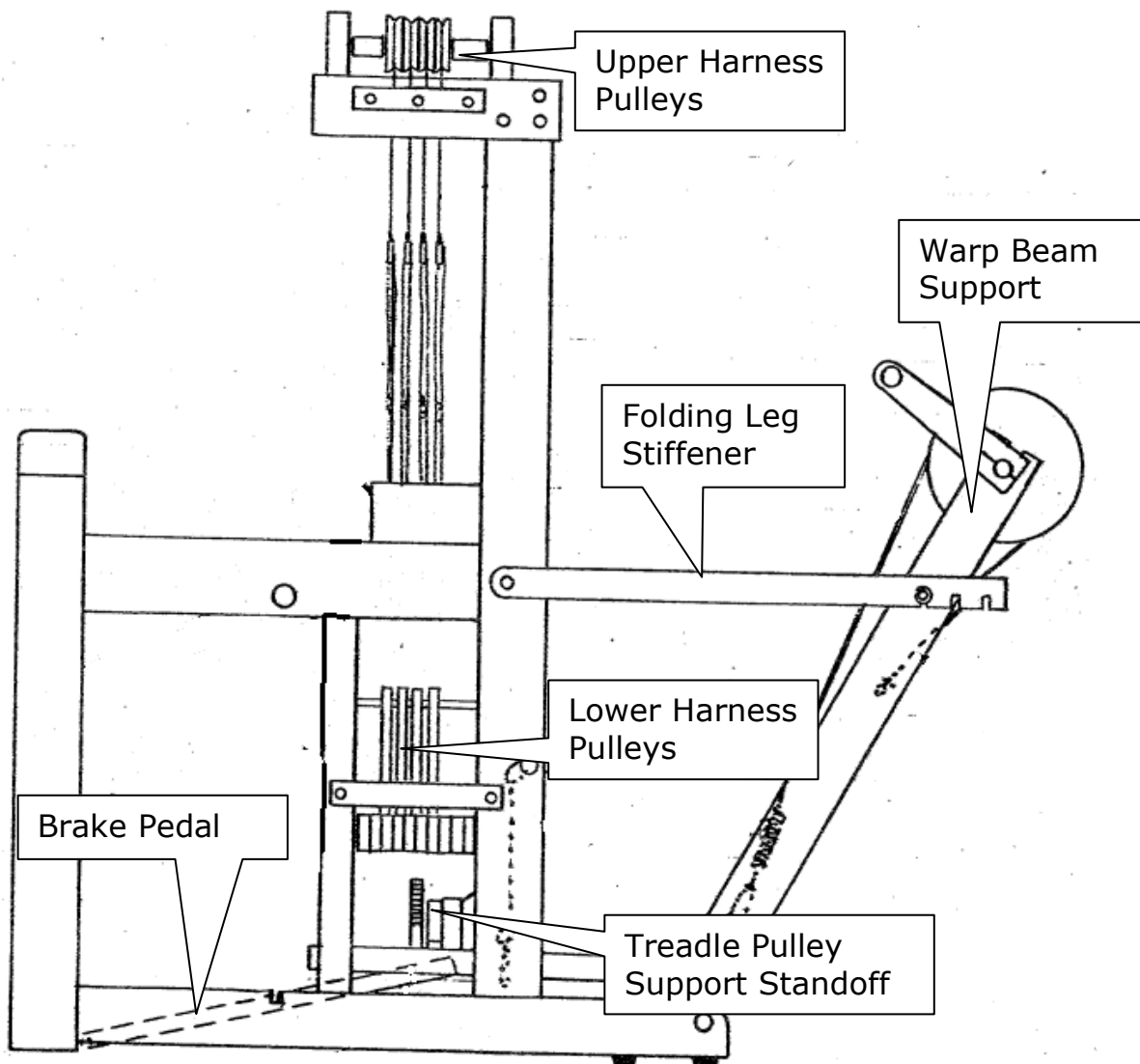

Figure 2 - Right Side Frame Diagram

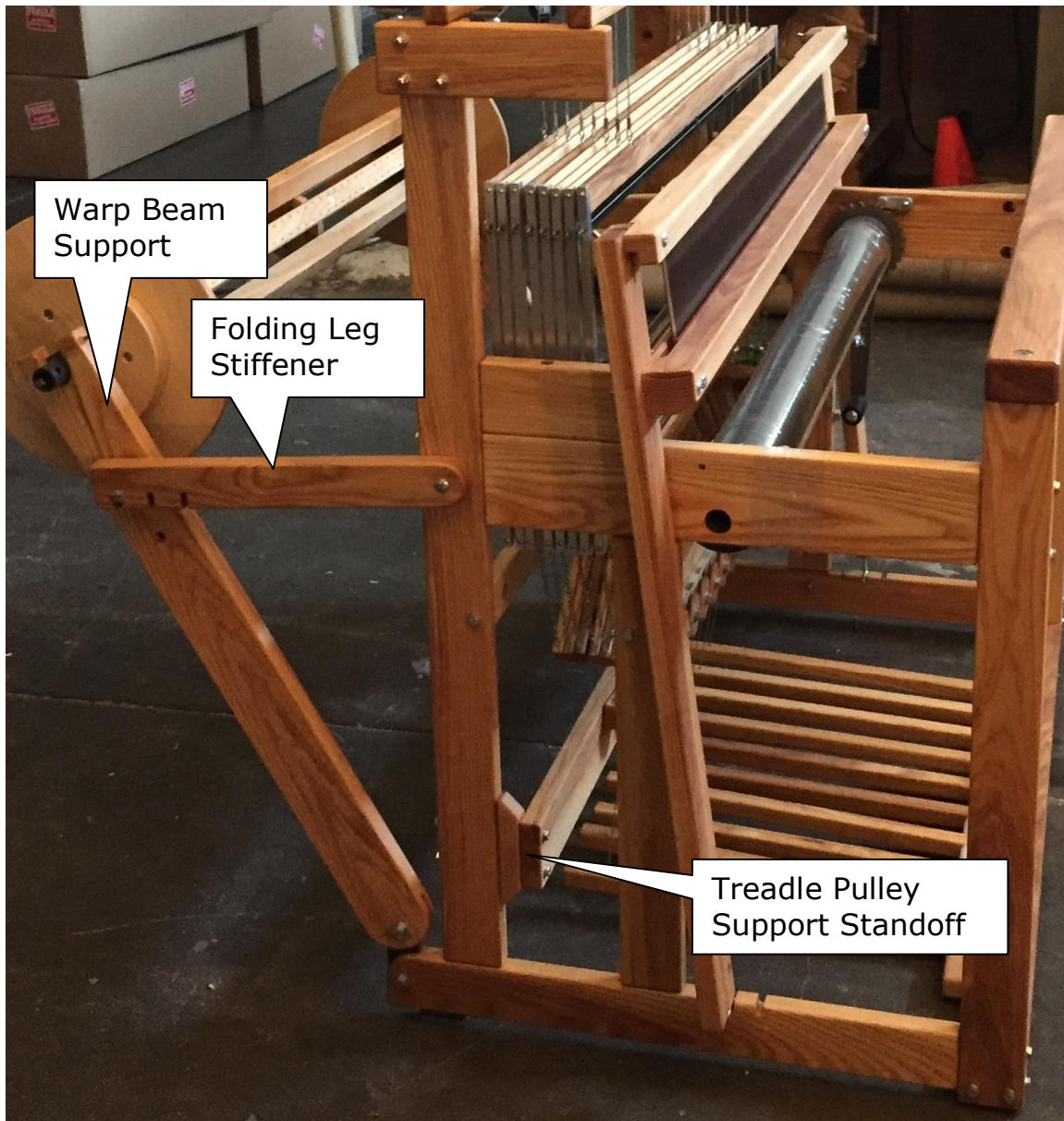

Figure 3 - Left Side Frame

- 2) Find the Treadle Pulley Support and the crossmember hardware packet.
- 3) Stand the Side Frames so that they are about the loom width apart.

- 4) Place the Treadle Pulley Support assembly between the frames against the stand-off.
- 5) Bolt the Treadle Pulley Support assembly in place to the Stand-offs.



Figure 4 - Treadle Pulley Support

ASSEMBLE FRONT LOWER CROSS MEMBER

- 1) Find the Front Lower (Treadle Pivot) Cross Member, ten (10) Treadles, and eight (8) Treadle Spacers.
- 2) Unscrew both End Blocks from the center of the Front Lower Cross Member to access the Pivot Rods. Leave the center block in position. Place the screws in a safe place.
- 3) Orient the surface of the Front Cross Member so that the bumpers face the floor.
- 4) Slide the Treadle onto the Pivot Rod so that the larger diameter Treadle Cable hole is facing the floor.
- 5) Slide one (1) Treadle Spacer on the Pivot Rod and place another treadle on the rod. Repeat this until you have five treadles on each pivot rod.
- 6) Reinstall the End Blocks.

FRONT CROSS MEMBER INSTALLATION

- 1) Install the assembled Front Cross Member (with Treadles) between both Side Frames at the lower front of the loom.



Figure 5 - Front member with treadles on loom

CLOTH STORAGE BEAM INSTALLATION

- 1) Locate the Cloth Storage Beam and Cloth Storage Crank/Handle.
- 2) Slide the Crank/Handle onto the Beam next to the Ratchet so that the handle faces the roller.
- 3) Spread the Side Frames apart slightly.



Figure 6 - Cloth Storage Beam

- 4) Insert the Cloth Storage Roller into the large holes on the Horizontal Member. The ratchet and handle go towards the right side of the loom.
- 5) Bring both Side Frames together around the Roller.

SPRING LEVER SUPPORT

The spring lever system is located directly underneath the harnesses and is made up of two rows of wooden levers with springs and chain between them. The purpose of these spring levers is to hold the unraised warp ends in the lower position, thereby giving you the best possible shed or opening to pass your shuttle through.

You will secure the spring lever support assembly to the loom at this point so you can reach the bolts. Once you have added the harnesses, you will hook the spring levers to the bottoms of the harnesses.

- 1) Find the spring lever support assembly.
- 2) Locate the correct holes in the side frame and attach the Spring Lever Support.



Figure 7 - Spring lever support assembly

TREADLE CABLE INSTALLATION AND ROUTING

- 1) The treadle cables are attached to the lower cable stop on the right side frame. Remove any wrapping from the cables.
- 2) Route the Cable from the outside of the loom, underneath the pulley below the Lower Cable Stop, over the top of the Treadle Pulley, and straight down to the end of the Treadle.

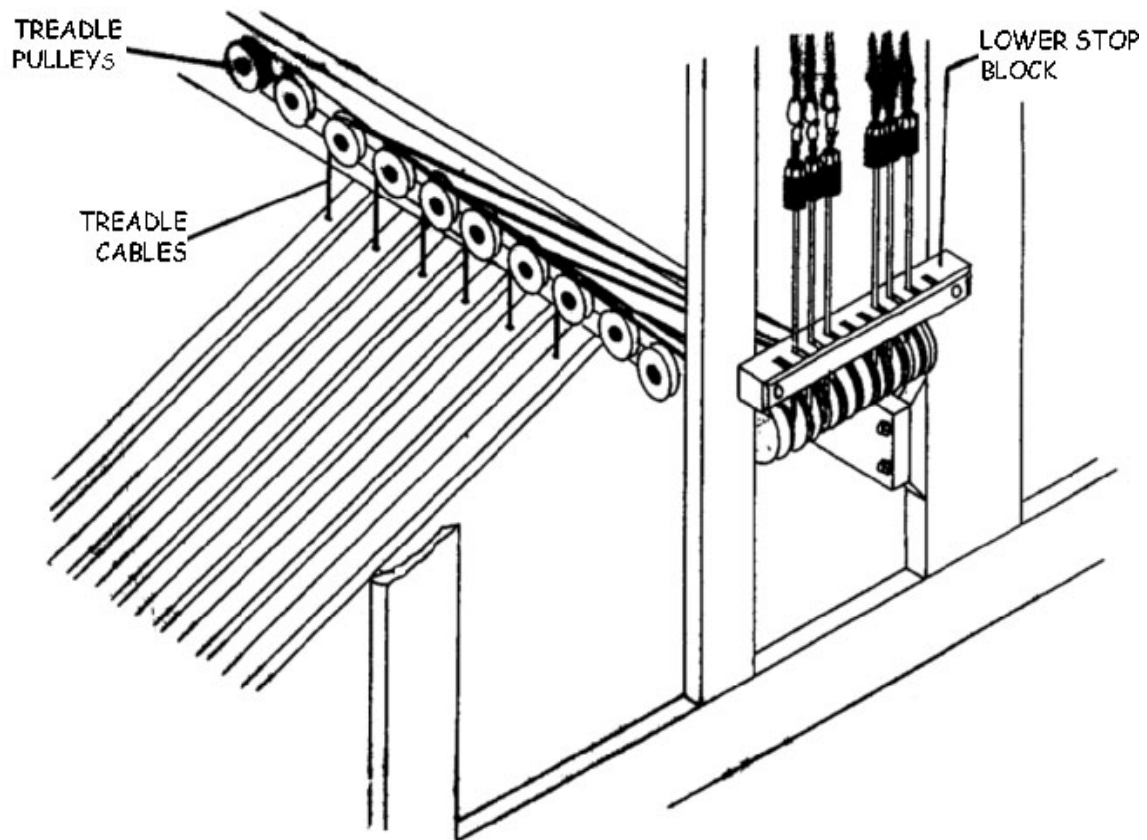

Figure 8 - Treadle cable routing

- 3) Push the end of the treadle cable into the hole at the end of the treadle from the top until the Nico protrudes from the bottom.

- 4) Slide a Cable Button on the extending cable and seat the Nico inside the Button.
- 5) Push the Button with the Nico inside, into the bottom hole of the Treadle.



Figure 9 - Nico secured with cable button

- 6) Repeat for all Treadle Cables.

SQUARE AND LEVEL THE LOOM

Now that you have completely assembled the Loom Frame, it is time to make sure that the frame is square and level.

Please make a note of this process, as it is an important part of the maintenance of your loom. Your loom will perform better and give more years of service if this process becomes a part of your regular loom maintenance.

- 1) Using a tape measure, note these measurements:
 - a. Right front leg to left rear leg
 - b. Left front leg to right rear leg
- 2) These two measurements should match. If they do not, you will need to adjust the frame slightly, by pushing and pulling at the corners, until they do match. The Frame will then be square.
- 3) Now, using a level, check the verticals at the corners and the cross pieces at bottom and top. Depending on the flooring, you may need

to use shims under the four corner verticals in order to achieve level.

- 4) Once the loom is square and level, check and tighten all bolts and nuts that connect the frame pieces.

Over time, due to the shaking and movement the loom experiences during use, these connections will shake loose, requiring periodic checking and tightening. Make a check of these components a regular part of your loom maintenance.

INSTALL THE HARNESS PULLEY SUPPORT ASSEMBLY

Note:

If you have the optional flyshuttle, the flystring supports are attached to the harness pulley support assembly. See page 40 for more information.

- 1) Locate the harness pulley support assembly. It is made of two pieces of wood, the width of your loom, held together by three sets of pulleys, two sets of which are close to one end.

Note:

The entire assembly is held together by shipping wrap and tape. Do not unwrap it until the unit is in place and ready to secure.

- 2) From your hardware pack, select the hardware for the harness pulley support assembly.
- 3) Orient the Harness Pulley Support Assembly on the top horizontals, so that the end with the two rows of pulleys is at the right side of the loom and the small plaque with your loom's serial number faces the front of the loom.

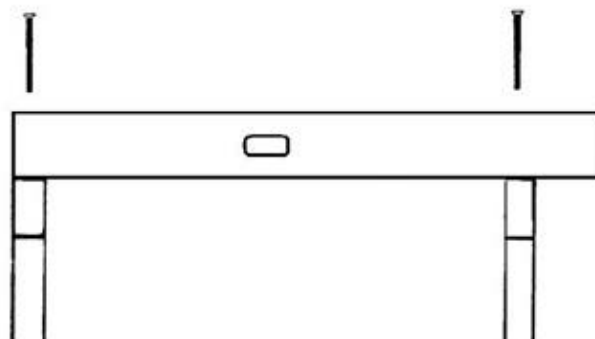

Figure 10 - Harness Pulley Support Assembly

- 4) Align the four mounting holes in the Pulley Supports with those in the Top Horizontals.

Note:

If you are not able to align the holes without removing the packing strips, take extra caution to move the Horizontals into place without pulling them apart.

- 5) Cut and carefully remove any remaining packing tape.
- 6) Without removing the plastic wrapping, insert the Flat Head Machine Screws into the four mounting holes. You will need to punch holes in the plastic. Once all 4 screws are in place remove the plastic and add the square nuts. Tighten securely.

HARNES ASSEMBLY

It's time to add the Harness Cables, Harnesses, and Harness Springs to your loom. If you ordered your loom with polyester heddles, you'll need to assemble your harnesses now. Please follow the directions below. You may wish to save space by mounting the Harness Frames as they are completed.

If your loom is equipped with metal heddles, proceed immediately to step #1 of the harness installation instructions.

Make Harness Assemblies

- 1) Locate the harness parts:

Harness Sticks	1 top & 1 bottom per harness
Harness Wires	2 per harness
Polyester Heddles	100 per harness

- 2) The sticks are divided into two groups: top and bottom sticks. The hooks on the top sticks are closer to the center. The hooks in the bottom sticks are closer to the edges.
- 3) Select one top and one bottom stick. Lay them on a table top parallel to one another, about 12" apart. Orient them so that the hooks point away from the opposite stick.

Note:

We provide 100 heddles per harness with your loom. Additional heddles can be purchased from us if needed. Our heddles are bundled in batches of 100.

- 4) Thread heddles onto the harness sticks and move them to the center.
- 5) Select two harness wires and slide one through the end hole of the top stick so that the copper fitting at the end of the harness wire is at the top. Insert the end of the wire without the fitting through the end hole of the bottom stick.

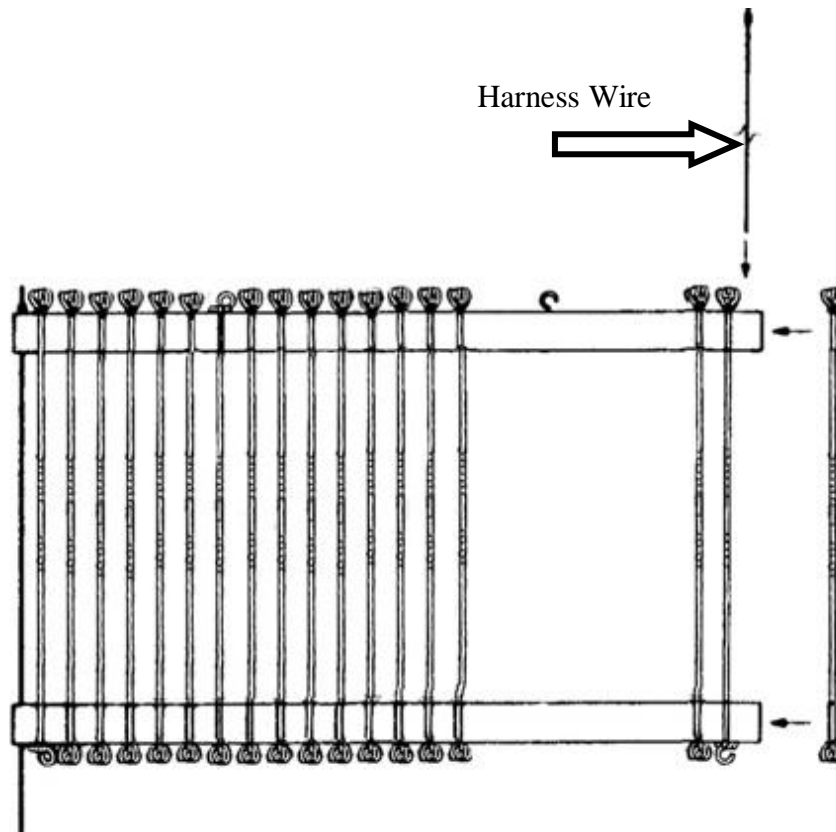

Figure 11 - Texsolv Heddle Installation

- 6) Add the second harness wire. Move one heddle out to either end of the harness, immediately adjacent to the harness wire. These two heddles will be helpful in maintaining the rectangular shape of the harness.
- 7) Repeat these steps to create each harness. You can mount each harness as it is assembled to save space by following the instructions in the next section.

Install The Harnesses And Springs

- 1) Unscrew both harness retainers at the top of the loom. Make sure to place the retainers and the screws in a safe place until you have installed all the harnesses.

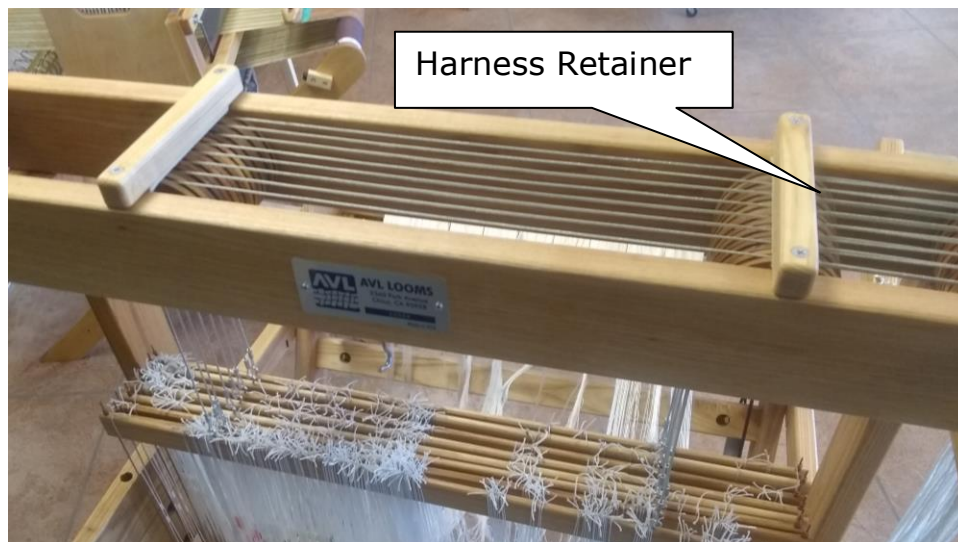

Figure 12 - Harness Retainers

- 2) The harness cables are bundled together and secured to the side frame. Remove the ties and select one. It is easier to hang the harnesses beginning at the back of the loom and moving forward. Each harness cable has two loops that fasten to the hooks on the harness sticks and one end with a clip that goes to the side tie-up.

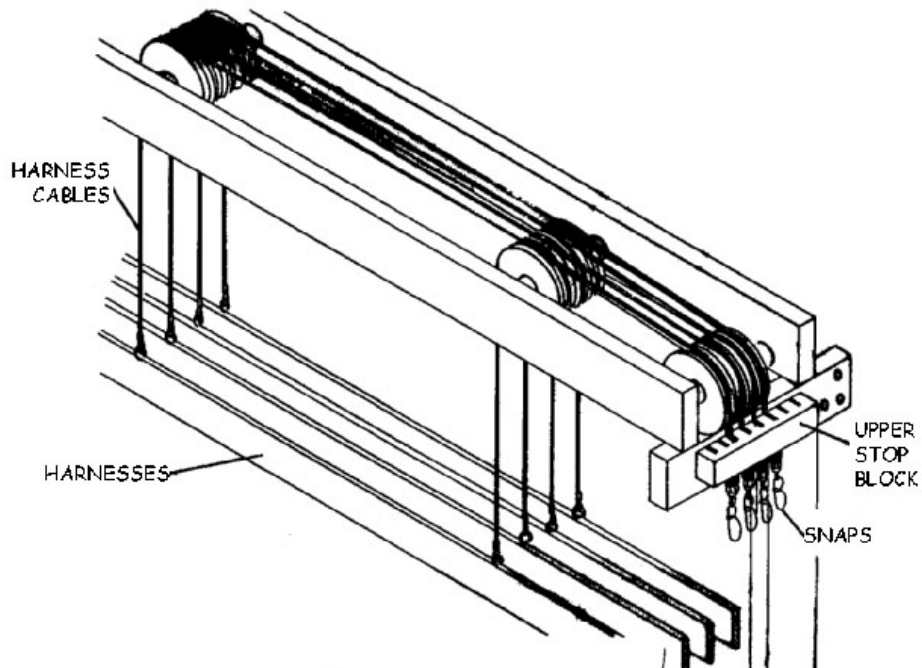

Figure 13 - Routing the harness cables

Note:

The clips currently used for the harness cables have a lever that is pushed open. If you have an earlier model of the home loom, the clips may be different.



Figure 14 - Harness Clip

- 3) Place the long end of the cable over the pulley furthest from the side tie-ups and the shorter piece over the middle pulley.

Note:

Check that the cable is not twisted on itself — this will cause problems when you are weaving.

- 4) Select a harness frame (metal heddles) or harness stick assembly (Polyester heddles). Either assembly will have two hooks, top and bottom. The hooks that are set closest together are at the TOP of the assembly.
- 5) Hang the harness assembly from the cable you just installed.
- 6) Once all the harnesses are installed, replace the harness retainers.

SPRING LEVER SYSTEM

The spring levers are attached to the bottom of the harnesses. Each set of spring levers is adjusted by tightening the chain attached to the spring. Generally speaking, the tighter the warp tension, the tighter the spring lever tension should be. You may also find that harnesses with a high number of warp ends will require a somewhat higher spring lever tension as well. You will know when you have achieved the proper amount of tension when the unraised warp ends all lay flat against the shuttle race.

For now, hook the end of the adjusting chain to the spring lever. Once you have the first warp on the loom, adjust the warp tension by changing which part of the chain is hooked to the spring lever.

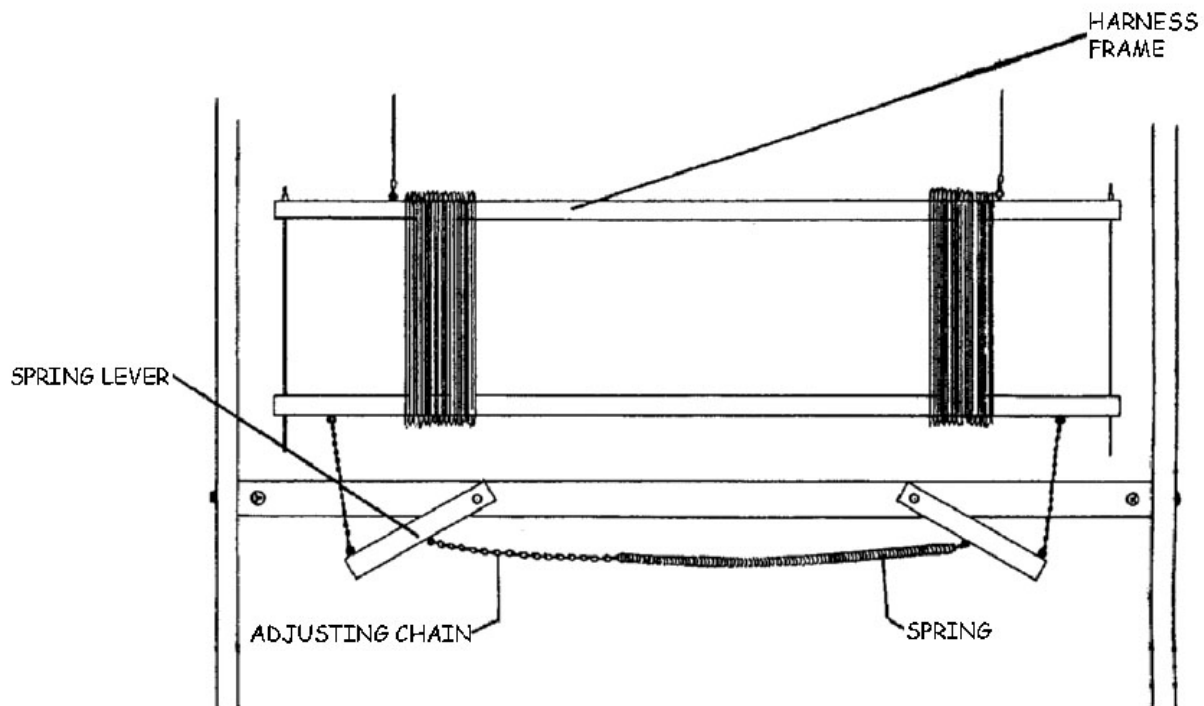

Figure 15 - Spring lever system

- 1) Locate a harness spring. Each of these springs has a chain worked into one end. You will fasten one of these spring and chain assemblies between each set of spring levers (immediately below the harnesses).
- 2) Find the corresponding set of spring levers. Each lever has a brass hook, which pivots on a brass pin. If the hooks are not already hanging free of their slots, pull them out now.
- 3) Link the end of the chain into the hook in the spring lever. Attach the spring end onto the hook in the opposing lever.

Note:

You may place the first chain on either the right or left spring lever but after that attach the remaining chains to the spring lever on the side you choose. All of the chains must be attached to the same side.

- 4) Hook the spring lever chains into the small hooks at the bottom of the harness. If you are using Polyester heddles, the frames will be unstable until you completed this connection. If you have trouble managing the harness frames, have a helper hold them in position.
- 5) Repeat these steps for each harness.



Figure 16 - Spring levers attached to harnesses

BREAST BEAM

- 1) Seat the Breast Beam flat on the Front Vertical Beams of the Side Frame and attach by screwing from the top down.

Note:

The Breast beam lacks holes at the end surfaces and is the larger of two pieces – do not confuse with folding leg stiffener.



Figure 17 - Breast Beam

BEATER ASSEMBLY

- 1) Locate the Beater Top, Beater Race, and Beater Legs (with 'J' hooks at bottom). The mounting hardware is included in bags.
- 2) Rest the Shuttle Race on the loom. The lengthwise groove that runs along one side should be at the top and facing toward the rear of the loom.

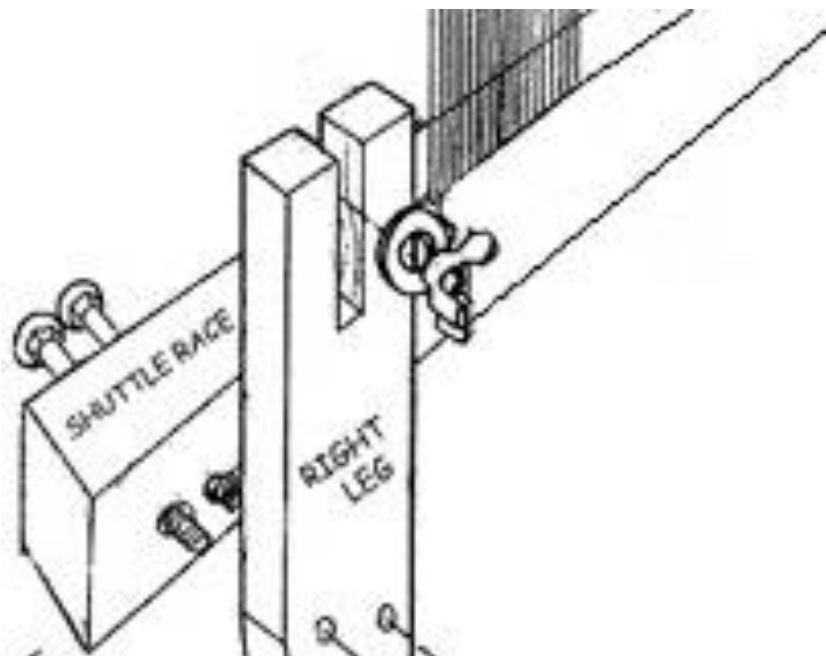

Figure 18 – Shuttle Race and Beater Leg

- 3) From the hardware bag choose the four 1/4" x 3-1/2" carriage bolts with washers and hex nuts.
- 4) Locate the Beater Legs. They are marked to show left and right. Place the bottom slot of each leg on the center grooves on the bottom of the side frames.

- 5) Line up the holes in the shuttle race with the corresponding holes in each leg and insert the bolts from the front of the race. Attach the washers and nuts and tighten only slightly.
- 6) Center your reed in the slot.

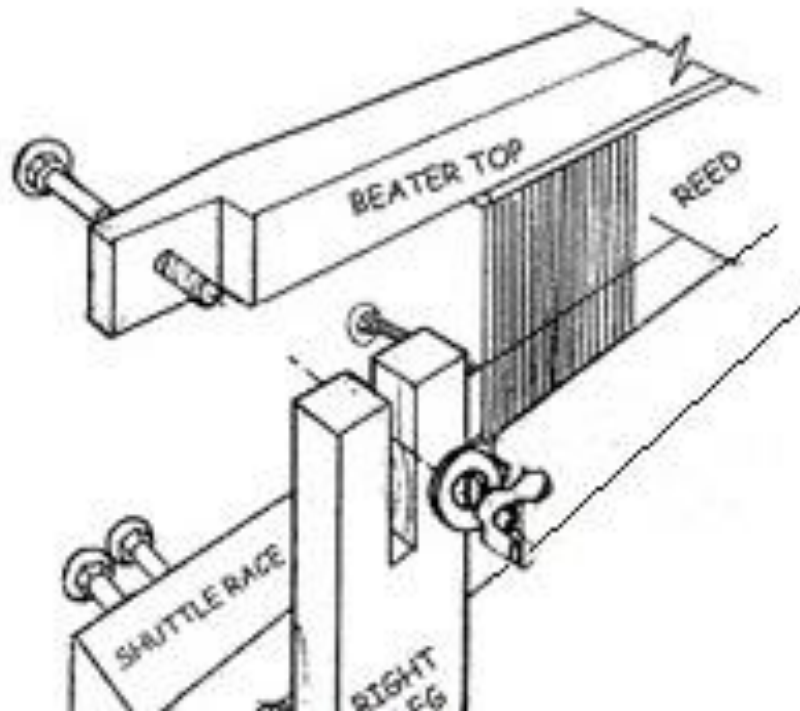

Figure 19 - Beater Top

- 7) Place the Beater Top on the reed so that the groove is facing down and the cut outs at either end are facing toward the rear of the loom.
- 8) Line up the holes in the Beater Top with the slots in each leg and insert the $\frac{1}{4}$ " x 2-3/4" bolts from the front of the Beater Top. Attach the washers and wing nuts and tighten **only slightly**.
- 9) Center the Beater Assembly in the loom.
- 10) Hold the Beater Top at its center and push the Beater all the way back, to meet the Beater Bumpers. Ensure that both sides of the Beater are touching the bumpers.
- 11) Check that the legs are spaced equally from the outer sides of the loom. Adjust as needed, with slight horizontal movements to the

Beater Top. This ensures that the legs will not rub on the loom frame.

- 12) Hold the Beater against the bumpers and tighten the bolts that attach the Beater Legs to the Shuttle Race and the Beater Top to the legs.



Figure 20 - Beater on loom

Beater Height

The height of the beater is adjustable to compensate for different weaving situations.

You should always make this adjustment while the warp is under tension and the beater is swung away from the weaver.

- 1) Lift the leg of the beater out of the notch.
- 2) Screw the steel pivot in or out to adjust the height of the beater.

Note:

Be sure to adjust both beater legs to the same height so that your beater is level.

- 3) Place the steel pivot back in the notch.

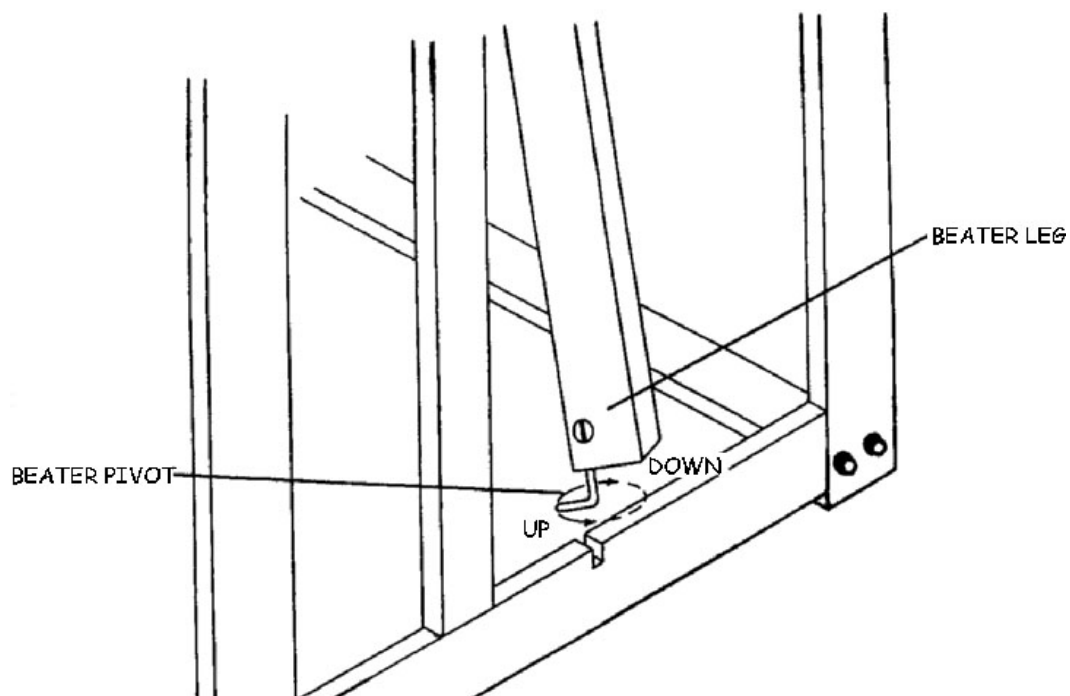

Figure 21 - Adjust the beater height

UNFOLDING THE WARP BEAM

- 1) Release the folding legs at the rear of the loom by loosening the wing nut from the carriage bolt on each side of the loom.

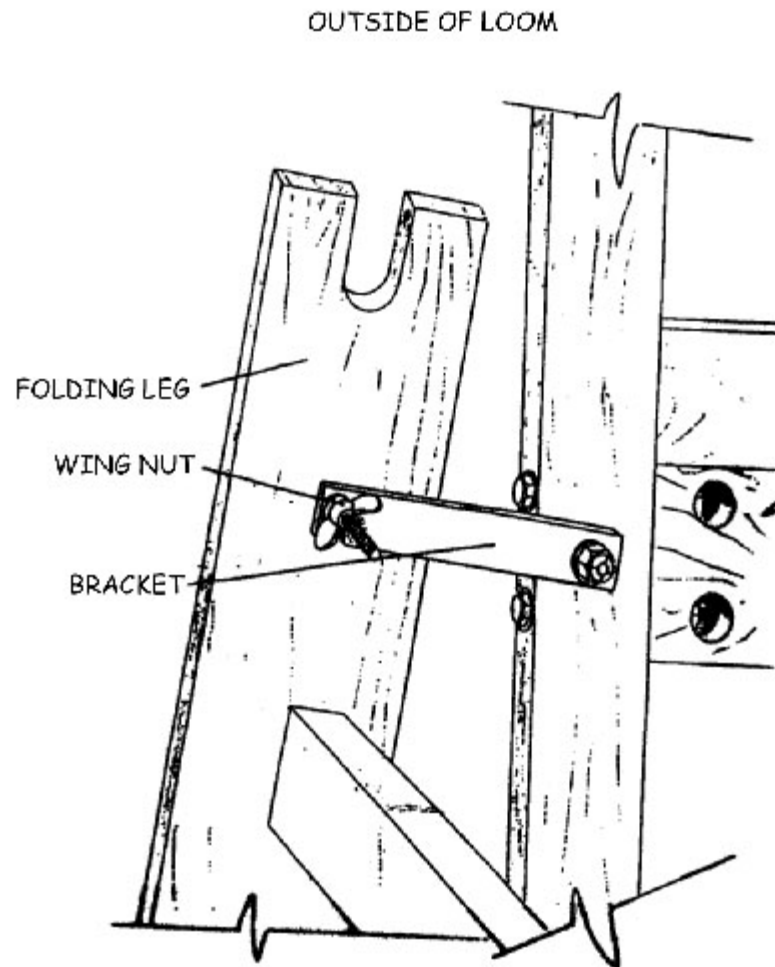

Figure 22 - Loom in folded position

- 2) Unfold the loom, holding the rear portion in place by swinging up the wooden support arms at either side of the loom and attaching them to each folding leg, using the same carriage bolts that held the loom in the folded position. Notice that there are slots in three positions on each support arm.



Figure 23 - Support arms for folding legs

- 3) Any of the three positions may be used to attach the loom at this point. This is an adjustable feature which allows the loom to accommodate a large amount of warp build up. With very long warps, weaving should start in the furthest back position, gradually moving to the next two settings as the warp is woven off. If you plan on using a raddle while warping the loom, use the position closest to the loom.

WARP BEAM PLACEMENT

The Home Loom comes with a plain beam as standard equipment. A sectional beam is available as an option.

- 1) Find the Warp Beam and place it so that the Brake Drum is to the right side of the loom.

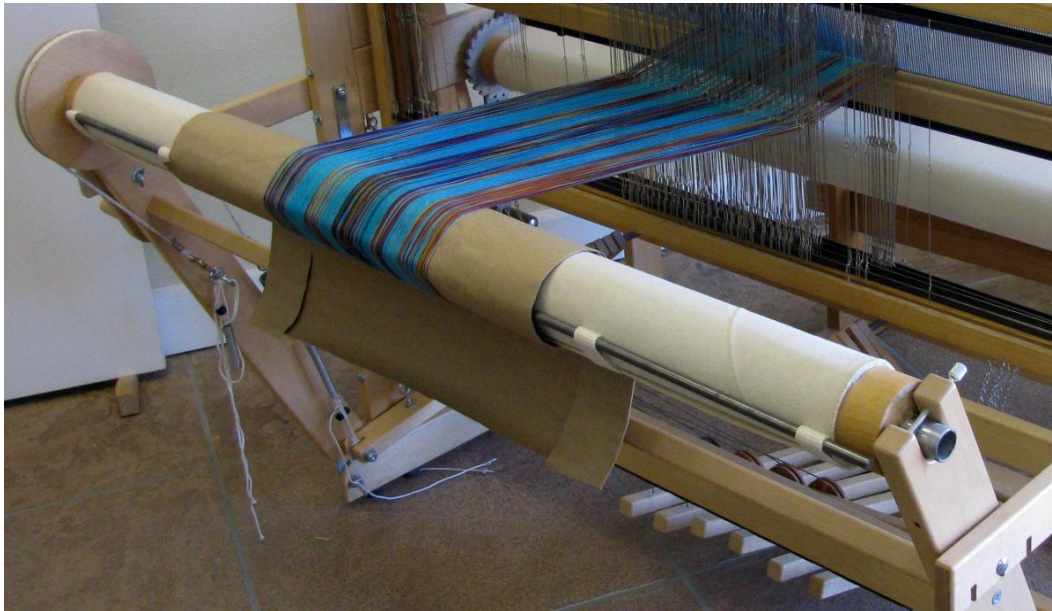

Figure 24 - Plain Beam on loom



Figure 25 - Sectional beam on loom

- 2) Seat the Beam on the slots at the top of both Folding legs.
- 3) Install the Warp Beam Handle outside of the Folding Leg on the Brake Drum side using the carriage bolt and wing nut.

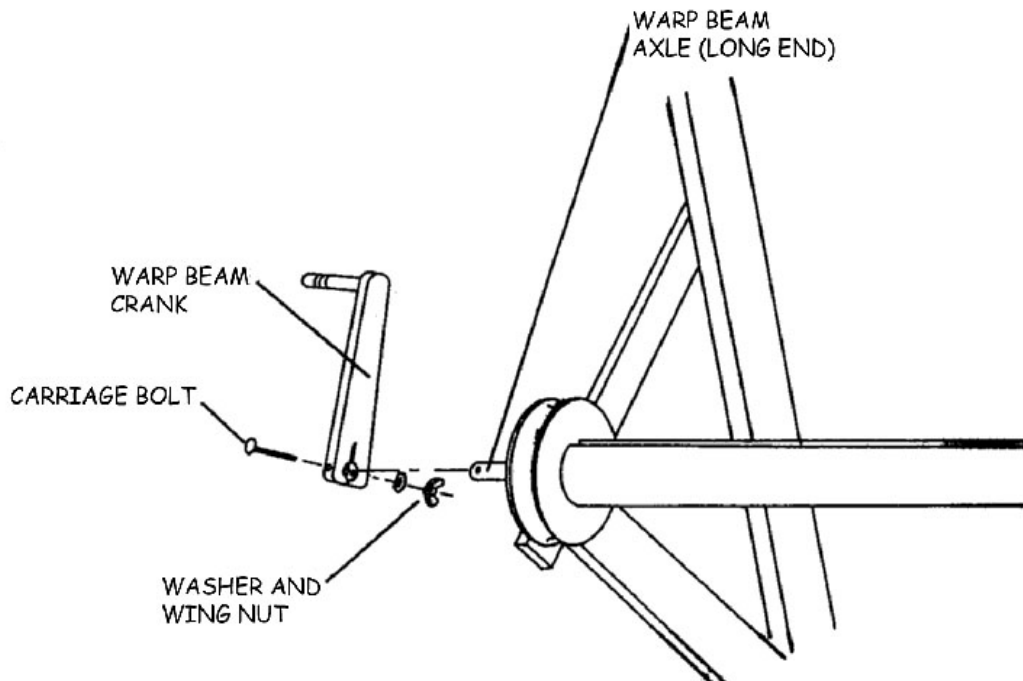

Figure 26 - Attach the warp beam crank

ATTACH THE BRAKE CABLE

The warp tension is determined by the combination of how you advance the warp with the cloth beam handle and when you let up on the brake pedal. The only adjustment you need to make here is to be sure that the brake adjustment cord is set tight enough so that the warp beam will fully lock when the brake pedal is in its upper (not depressed) position. It is good practice to tie a simple knot or bow tie around the plastic cord clamp once you have set the tension. This way you will be certain that the cord will not slip and your tension will remain constant.

A steel lever is already attached to the side of the loom with cords attaching it to the locking brake in two places. The cord attached to the end of the brake nearest the warp beam has a spring and an adjusting cord that can be used to adjust the tension on the warp.

NOTE:

The brake adjustment cord should be loosened whenever you wind the beam backwards, such as when you are winding a warp onto the beam.

- 1) Locate the brake cable.
- 2) Attach the end of the brake cable to the hook on the outside edge of the folding leg.

- 3) Take the brake cable from the outside of the loom over the top of the brake drum.
- 4) Wrap the cable around the top of the brake drum three times.



Figure 27 - Warp beam cable

- 5) Attach the clip at the end of the warp beam brake cable to the steel ring at the end of the steel brake lever.

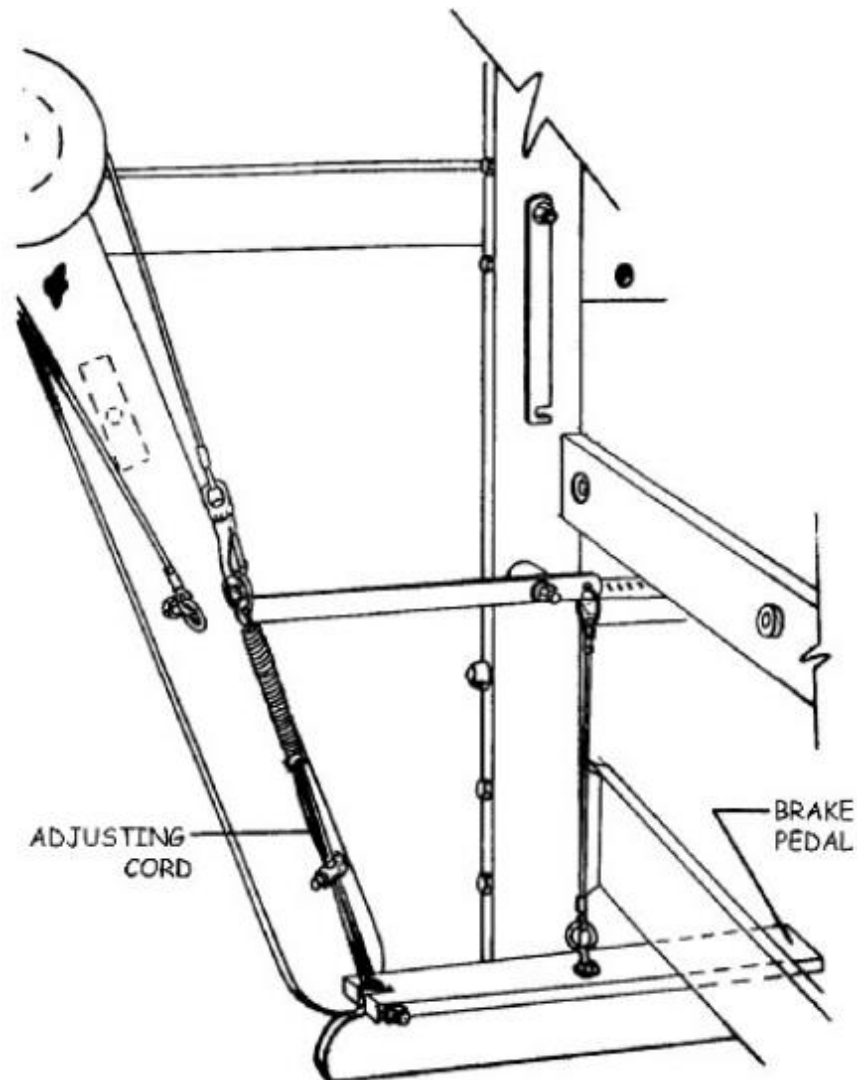

Figure 28 - Brake cable attached to steel brake lever

- 6) Adjust the cord at the end of the locking brake by pressing the button on the toggle to add or release tension. It is good practice to tie off the ends of the cord once the tension is adjusted, so that the cord does not slip.

APPENDIX – OPTIONAL FEATURES

TENSION BOX (OPTIONAL)

If you ordered a sectional beam for your loom, you may use a tension box for warping. On the home loom, the tension box is supported with longer folding leg supports. If you have a warping wheel, you do not need to use the tension box system.

- 1) Remove the folding leg support arms saving the bolts, nuts, and locking levers.
- 2) Attach the extended support arms and secure to the folding legs.
- 3) Be sure to insert the bolt from the outside, through the support arms and castle side, then slip the locking lever on as before. Next, screw on the nut.

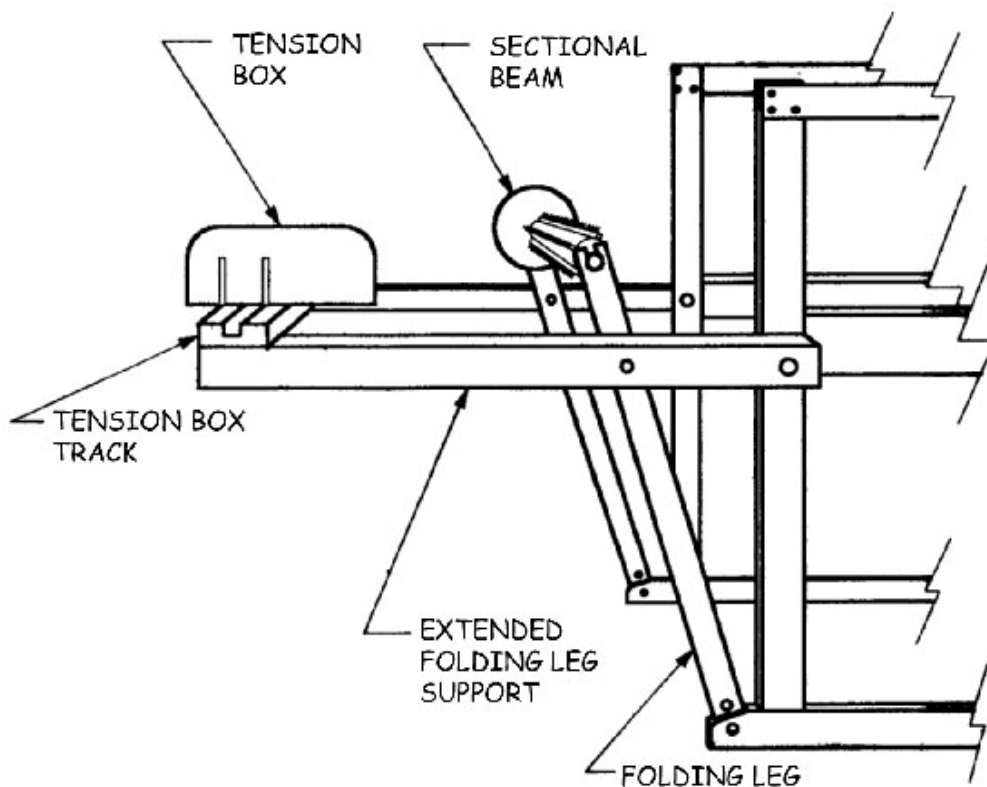

Figure 29 - Tension box on a home loom

- 4) Secure one folding leg to each support arm with the washers and nuts to the inside.

- 5) Mount your tension box track to the top rear of the support arms with the lengthwise groove facing up.

STORAGE SHELF (OPTIONAL)

An optional storage shelf is available for the Home Loom. It allows you to place items you wish to keep close on top of the loom.

- 1) Place the shelf on top of the loom so that it fits snugly over the harness retainers.



Figure 30 - Home Loom with top shelf

FLYSHUTTLE (OPTIONAL)

- 1) Locate the Beater Top, Beater Race, Beater Legs (with 'J' hooks at bottom), and flyshuttle boxes. The mounting hardware is included in bags.

- 2) Rest the Shuttle Race on the loom. The lengthwise groove that runs along one side should be at the top and facing toward the rear of the loom.

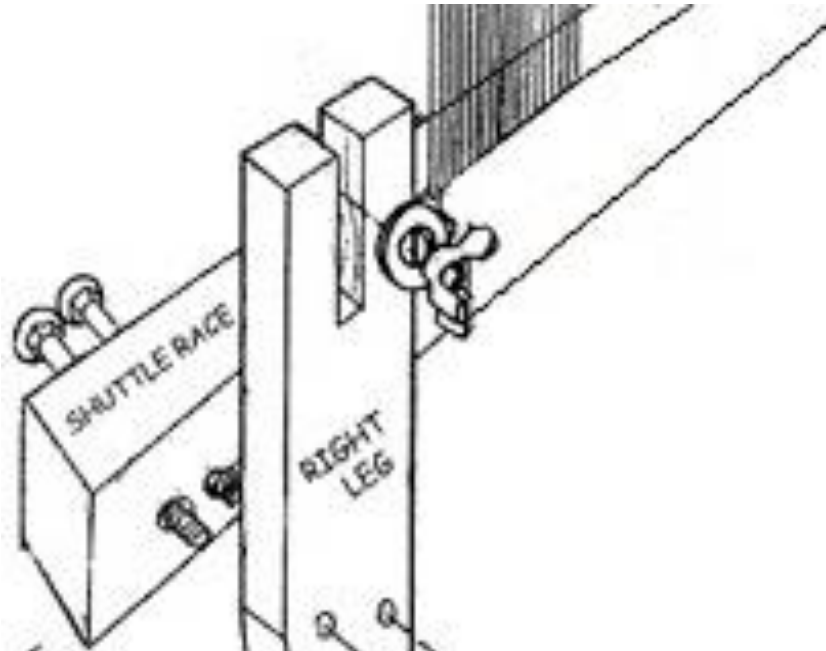

Figure 31 – Shuttle Race and Beater Leg

- 3) From the hardware bag choose the long carriage bolts with washers and hex nuts.
- 4) Locate the Beater Legs. They are marked to show left and right. Place the bottom slot of each leg on the center grooves on the bottom of the side frames.
- 5) Line up the holes in the shuttle race with the corresponding holes in each leg.
- 6) Slide the flyshuttle box over the shuttle race so that the back is next to the leg and the front is at the front of the beater. There are predrilled holes that match the holes in the shuttle race and leg.

Note:

There are two holes that connect the beater leg, race and flyshuttle box. There is an additional hole that goes through only the race and the flyshuttle box. If you are adding a flyshuttle to an existing loom, you may need to drill the additional hole into the race. A diagram will be provided.



Figure 32 - Flyshuttle box on beater

- 7) Place the bolts through the holes. Attach the washers and nuts and tighten only slightly.
- 8) Center your reed in the slot.

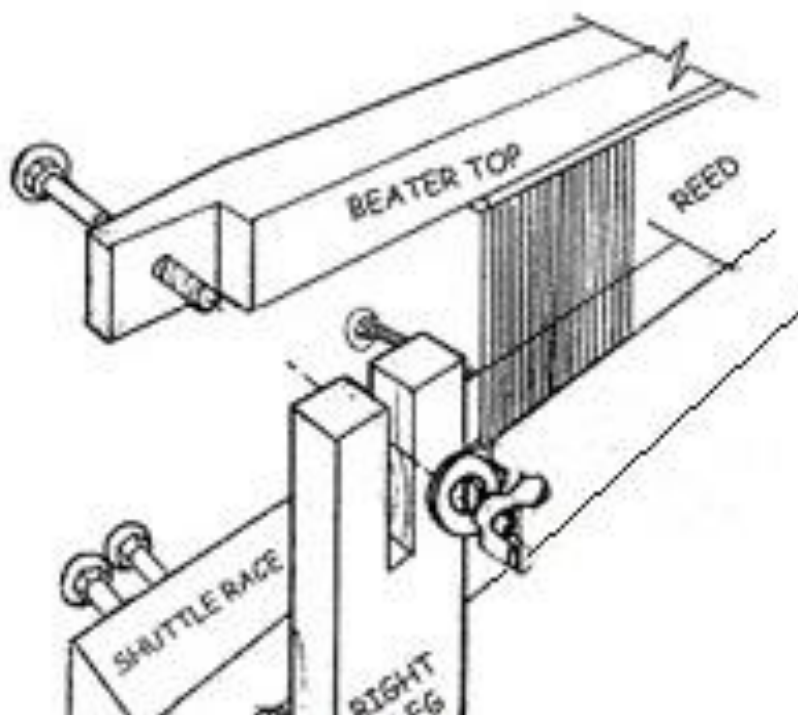

Figure 33 - Beater Top

- 9) Place the Beater Top on the reed so that the groove is facing down and the cut outs at either end are facing toward the rear of the loom.
- 10) Line up the holes in the Beater Top with the slots in each leg and insert the ¼" x 2-3/4" bolts from the front of the Beater Top. Attach the washers and wing nuts and tighten **only slightly**.
- 11) Center the Beater Assembly in the loom.
- 12) Hold the Beater Top at its center and push the Beater all the way back, to meet the Beater Bumpers. Ensure that both sides of the Beater are touching the bumpers.
- 13) Check that the legs are spaced equally from the outer sides of the loom. Adjust as needed, with slight horizontal movements to the Beater Top. This ensures that the legs will not rub on the loom frame.
- 14) Make sure that the flyshuttle box is even with the shuttle race, so that the shuttle will move smoothly.

Note:

You may need a helper to hold the flyshuttle and beater together correctly while you tighten the remaining bolts.

- 15) Hold the Beater against the bumpers and tighten the bolts that attach the Beater Legs to the Shuttle Race and the Beater Top to the legs.

Flyshuttle Tie-Up

The flyshuttle tie-up is attached to the harness pulley support. If you ordered the flyshuttle with your loom, some hardware pieces may already be attached to the loom. If you ordered the flyshuttle as an add-on to an existing loom, you will have to install all of the hardware as described in the following section.

- 1) When installing the harness pulley support assembly, place a flystring support on each side over the mounting holes on the edges of the harness pulley support assembly.
- 2) Insert the mounting hardware through the flystring support into the harness pulley support assembly and into the loom. Attach a nut to each bolt and tighten.



Figure 34 - Flystring support on loom

- 3) Take the hook from the hardware package and screw it into the center hole on the underside of the front harness pulley support so that no screw threads are showing.
- 4) The handle has a screweye at the top and one at each side with cords attached. Place the handle on the hook in the center of the harness pulley support.

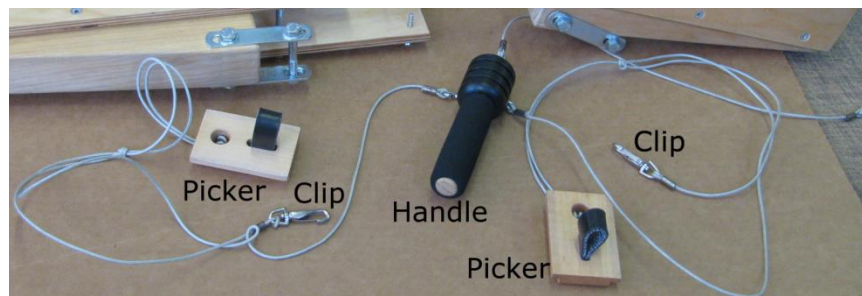

Figure 35 - String tie-up and handle

- 5) There are two pickers hanging below the handle. These are wooden pieces which have a leather loop and cord attached. Take one of these and place it so that the leather loop is toward the bottom.
- 6) Slide the picker into the slots on the top of one flyshuttle box. The leather loop should be down and to the outside.
- 7) Attach the clip at the end of the cord coming from the picker to the screweye on the flystring supports. Make sure the cord goes over the top of the snubber. The snubber is a small, round plastic piece above the shuttle box.



- 8) Repeat for the other side making sure that the picker loop is down and toward the outside.

AUTOMATIC WARP TENSIONING SYSTEM (OPTIONAL)

The optional automatic warp tensioning system allows the warp to advance without the weaver having to depress the brake pedal. The brake cable provides enough tension to hold the warp tight during weaving, but a spring allows the warp to advance as the weaver beats.

A steel lever is already attached to the side of the loom with cords attaching it to the locking brake in two places. The cord attached to the end of the brake nearest the warp beam has a spring and an adjusting cord that can be used to adjust the tension on the warp.

NOTE:

The brake adjustment cord should be loosened whenever you wind the beam backwards, such as when you are winding a warp onto the beam.

- 1) Locate the brake cable.
- 2) Attach the spring at the end of the brake cable to the hook on the outside edge of the folding leg.



Figure 36 - Spring for brake cable

- 3) Take the brake cable from the outside of the loom over the top of the brake drum.
- 4) Wrap the cable around the top of the brake drum three times.



Figure 37 - Warp beam cable

- 5) Attach the clip at the end of the warp beam brake cable to the steel ring at the end of the steel brake lever.

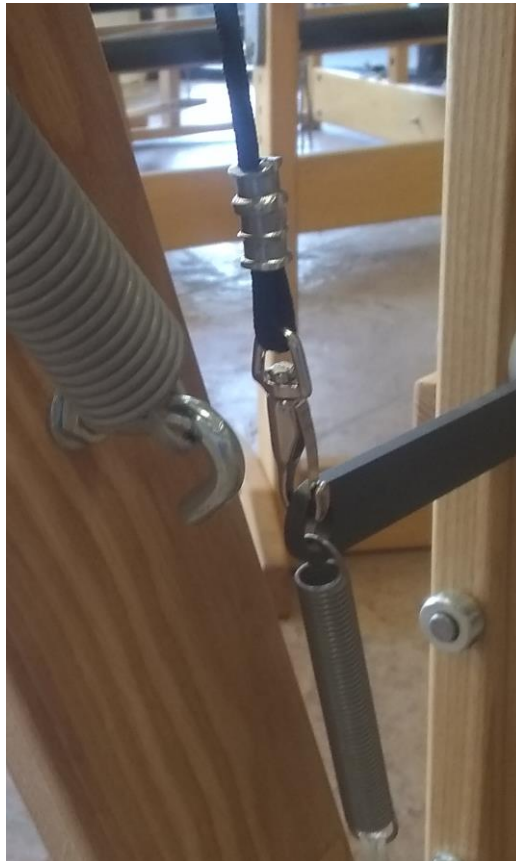

Figure 38 - Brake cable attached to steel brake lever

- 6) Adjust the cord at the end of the locking brake by pressing the button on the toggle to add or release tension. It is good practice to tie off the ends of the cord once the tension is adjusted, so that the cord does not slip.

SECOND BEAM SYSTEM (OPTIONAL)

An additional set of brackets at the end of the warp beam supports allow a second beam to be added to the home loom. Only a plain beam can be used with this system. If you ordered the second beam system when you ordered your loom, the brackets may be attached when you receive the loom. If they are not, follow the instructions below.

Note:

If the loom has two warp beams, there will be a locking brake on each side of the loom. Use the one on the right for the primary warp beam as described on page 30 and use the one on the left for the second warp beam.

- 1) Find the brackets and the hardware package for the second beam system.
- 2) Slide the bolts through the holes in the warp beam support legs.
- 3) Slide the bracket for the second beam onto the bolts with the access holes facing the interior of the loom.



Figure 39 - Second beam bracket on loom

- 4) Secure the bolts with the nuts.
- 5) Place the second beam into the brackets with the brake drum on the left side of the loom.
- 6) Attach the brake cable as you did for the primary warp beam.

WEAVING INSTRUCTIONS

Note:

Unless otherwise noted, the instructions in this section are basic, general instructions for weaving and are applicable to many AVL and non-AVL looms. They should not be regarded as a substitute for training or experience.

WARPING THE PLAIN BEAM

If you only have a Sectional Beam, proceed to the section titled Warping the Sectional Beam.

Various warping methods can be adapted to an AVL loom. However, we recommend the following method in which the warp is wound on to the Plain Beam with the use of a Raddle. Please study this method and try it. We have found that it aids in getting a uniform warp tension, especially when dealing with long warps.

Creating Two Crosses

To begin, wind the warp on a warping board or reel. Make sure you put in two crosses, one at each end of your warp:

- 1) The Threading Cross (each thread crosses the next thread in opposite directions; all are secured in a single loop).

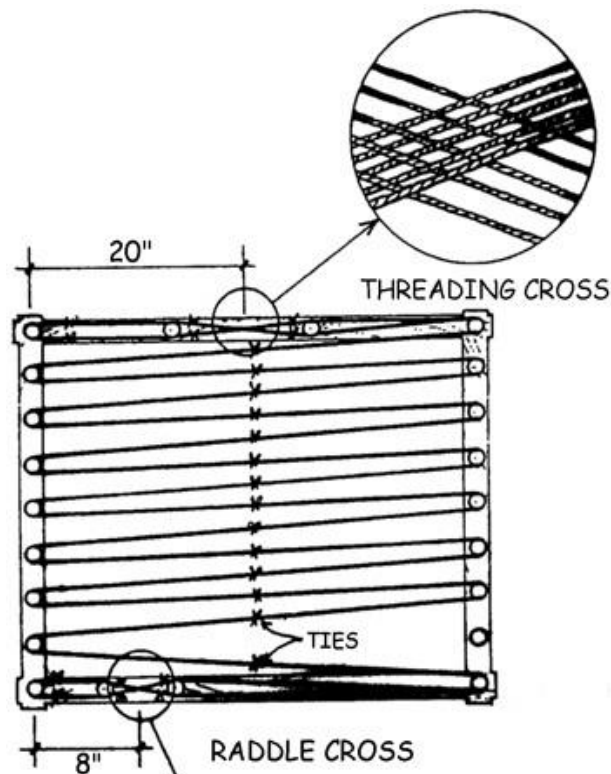

Figure 40 - Warping Board with Two Crosses

- 2) The Raddle Cross (warp threads are tied in groups, depending on how many ends will be put in each section of the raddle).

Securing The Crosses

Before removing the warp from the board or the reel, secure the crosses. Use four ties to secure each cross, in addition to the tie at the cross axis. These ties go on each side of both pegs holding the cross.

It is usually a good idea to use different color threads for the ties on the tops of the pegs and another color to tie the bows underneath the pegs. By color coding your ties, you are less likely to twist the warp later.

Removing The Warp For The Warping Board

Remove the warp from the warping board by chaining or by winding on the kitestick. Start from the threading cross and proceed to the raddle cross.

Since the capacity of the warping board is limited, for wide warps you will end up making a number of mini-warps and taking them off individually.

Adjusting The Tension

Before winding on the warp, check the tension device to make sure the cable is wrapped three times around the tension drum. Test that you are able to turn the Beam in a clockwise direction. If this proves difficult, you can let some length out of the nylon cord by pressing on the toggle button and moving the toggle up and down on the cord. This will allow you to turn the beam backwards during winding and the Beam will be stabilized when at rest. Don't forget to retighten the cord when you are ready to thread the heddles!

Attaching The Raddle

Secure the Raddle to the back of the loom. If you have an AVL Raddle, simply slip the mounting rods into the set of holes in the back of the rear vertical members.

Winding The Apron

Put your apron on the beam with velcro and wind your beam clockwise, so that your apron is wound on the beam. When weaving, the warp needs to come off the top of the warp beam into the loom. When warping, the warp should come around the bottom of the beam.

Attaching The Warp To The Apron

Put the metal rod through the sleeve at the end of the apron. You can lash your warp sections onto that rod or you can attach another rod which has been slipped through the loop at the end of the warp with the Raddle Cross.

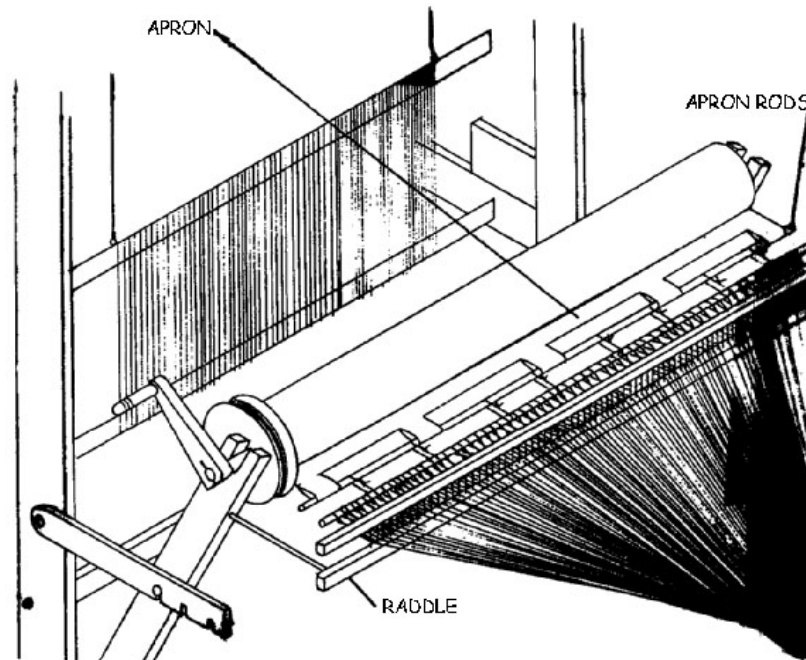

Figure 41 - Using the Warp Beam Apron

Inserting Sticks In The Raddle Cross

Place two lease sticks in the raddle cross and secure together with string through the holes in the ends of the sticks. Now remove the ties from the raddle cross and spread the warp out on the sticks.

Find the center of your raddle to use it as a center of your warp. Then measure out to the edge of your warp to determine which raddle dent to start with.

Feeding The Raddle

To feed the raddle, distribute yarns through the raddle by dropping each raddle cross group into a dent in the raddle.

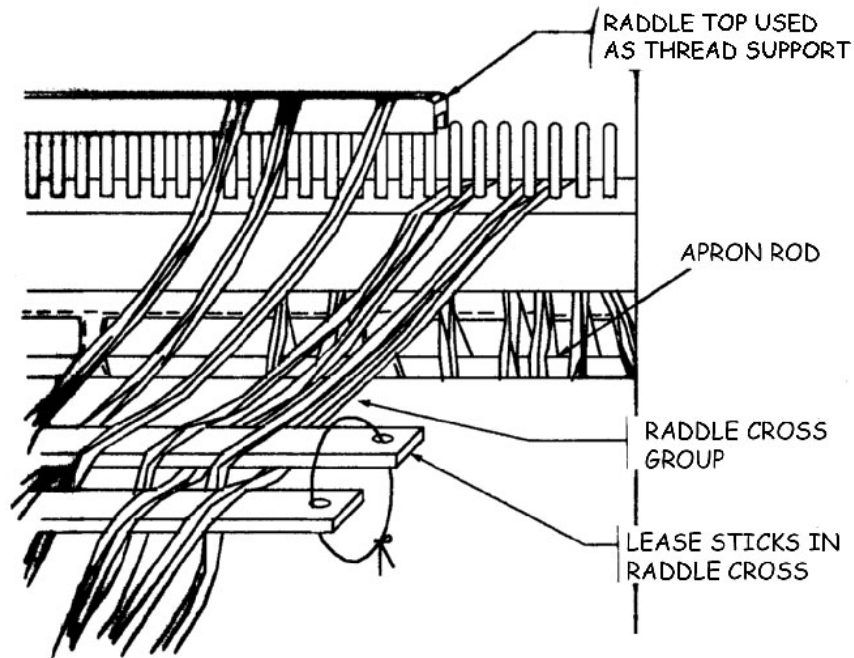

Figure 42 - Feeding the Raddle

If you are using an AVL raddle with a sliding cover, slide it on after the raddle is threaded and secure it with two or three cord ties so it can't come off. Remove the raddle cross sticks when this is completed.

Preparing The Paper

Prepare the paper for winding between the warp layers. Again, for the most professional results, and fewer tension problems, we suggest that the warp be as smooth, tight, and compact as possible. This would mean not using corrugated paper or sticks as they will make the warp too fat and/or lumpy. Corrugated paper is just too soft and the warp can never be wound tight enough with it. Heavy wrapping paper works well; seventy pound craft paper is good. If you are going to be using smooth, slippery warp yarns like fine linens or perle cottons, the edge yarns are going to need extra help in order not to slip off.

To do this, cut your paper four inches wider than the warp width and then fold over the edges an inch on each side. Be sure the warp is wound between the two folded edges not overlapping them.

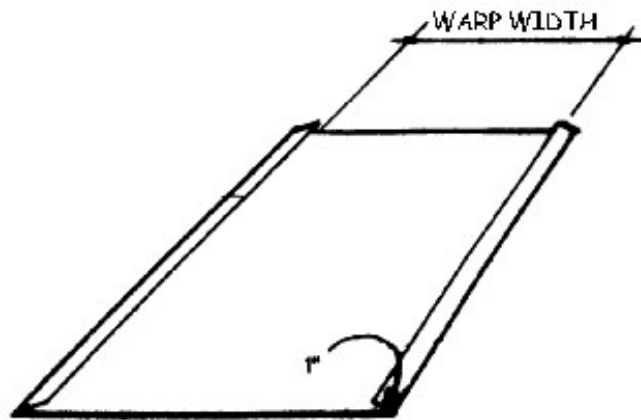
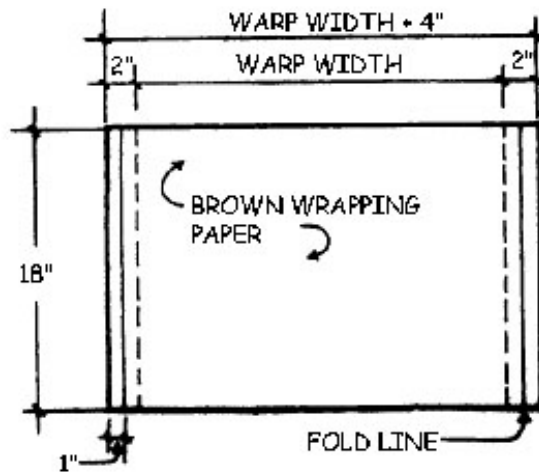

Figure 43 - Prepared Paper with Folded Edge

Winding The Warp

When winding the warp on from the back, i.e., with the warp spread out in back of the loom, turn the crank in a clockwise direction so that the warp comes in from the bottom.

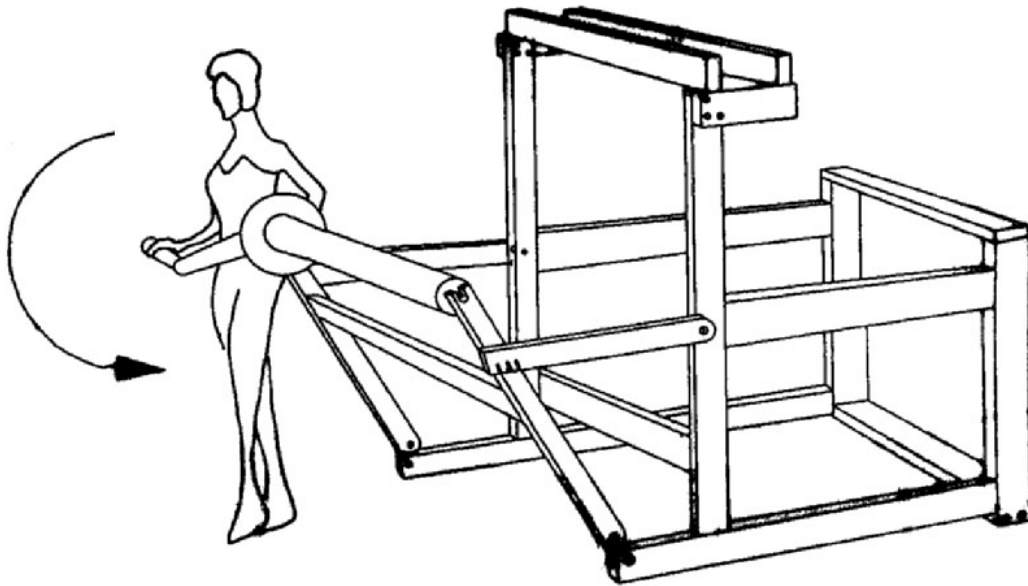

Figure 44 - Winding on the Warp

Remember, wind the warp on tightly under a lot of tension. The amount of tension used will vary depending on the warp material, but a good rule to remember is that the tension of the wound-on warp must be as great as the tension during the weaving operation. You will need one person to hold a warp under tension on the back and one person to wind the warp on the beam using a handle. The person winding the warp can also insert the paper. For a wide, heavy warp, several helpers may be required.

If you have to do it yourself, you can use the jerking method. Make one turn around with your beam crank and then go to the back of the loom and jerk one narrow section (2-3 inches in width) at a time to make the newly wound warp tight on the beam. The idea of this method is that the warp does not need to be under tension all the time, but the part that is on the beam has to be tight. Make another turn, go to the back of the loom, and jerk all the sections again and so on. If you have a wide warp, you might need to do multiple jerking motions after each turn.

Threading Cross

When you come to the end of your warp, insert lease sticks in your threading cross.

Now remove the ties from each individual threading cross and spread the warp out on the sticks.

Removing The Raddle

When the warping is completed, free the warp from the raddle. If you have an AVL raddle, first untie the security strings, lift the raddle top off, and remove the warp from the raddle. Afterwards, replace the top on the raddle and leave it in its place on the back of the loom if so desired as it will not interfere with the weaving process.

Using a strong cord, suspend the lease sticks between the Separation Beam and the Harnesses.

Now remove the ties from each Threading Cross and spread the warp out on the sticks.

Using Two Beams

There will be times when you will want to use more than one warp, which cannot be put together on one beam.

You will have to put them on separate beams with separate tension systems.

When Do You Need To Tension Your Warps Separately?

When weaving:

1. Very different size yarns.
2. Yarns with different stretching qualities.
3. Different densities.
4. Different structures.
5. Supplementary warp techniques (because some warp threads do not interlace as often as others).
6. A group of special yarns for selvages and borders. Loops, piles, or puckers like seersucker.
7. More than one layer with different setts in each layer.
8. More than one layer with a different pick count in each layer.

Setting Two Beams

The process of setting up a second beam is the same as setting up one beam. You need to be careful not to mix sequences between the beams. It will also take more time to setup two beams rather than one.

An optional second beam setup is available for the Home Loom. It allows you to have two plain beams on the loom. A second set of brackets is added to the folding legs to hold a second beam.

- 1) Wind each warp on the beam the same way you would do it if there were only one beam on the loom (plain or sectional). Make a cross and have a pair of lease sticks with a cross in each warp.
- 2) Proceed with a threading as if you were only working with one beam. Follow your threading instructions and take special care which thread from which pair of lease sticks comes next.

More Than Two Warps, Only One Beam? Separate Tensioning!

If you do not currently have two beams, or you need more than two separate warps, you can weight and tension your additional warps separately on the same beam. Follow the instructions below.

- 1) Make your warp sections on the warping board and take them off the board in a chain, on a kite stick, or just in a plastic bag.
- 2) Make sure that each bundle is not too thick. You will know when you need to divide each bundle if you feel that all the threads are not being tensioned evenly.
- 3) The weight needs to have a strong loop of string on it so the warp bundles can be slip knotted into it. This makes it easy to undo the slip-knot and move the weight when it climbs up to the back beam and must be let down again.
- 4) The weight also needs to be adjustable. Plastic bottles, with handles, filled with water are perfect. You can also use fishing weights, washers, nuts, bolts. They are not as easily adjustable as water bottles, but take less space. The closer to the floor you can hang them, the less often you need to reposition them.

WARPING THE SECTIONAL BEAM

The AVL Sectional Beam can be warped in sections with the use of a Tension Box. The yarn travels directly from cones or spools, which are mounted on a rack behind the loom, through the Tension Box, and onto the Beam. Throughout the warping process, the Tension Box automatically keeps a constant and uniform tension on the warp. The Tension Box allows you to make longer warps than other methods.

You can also warp a sectional beam using the AVL Warping Wheel. With the AVL Warping Wheel you wind threads onto the wheel then wind them from

the wheel directly onto the beam. When using a warping wheel, your warp length will need to be less than 24 yards.

Extension Cords

You might want to make a permanent set of Extension Cords to use when warping the Sectional Beam. Extension Cords are also called “apron cords” and serve the same function as the apron on the Plain Beam. They give you “reach” from the Warp Beam and allow you to weave every possible inch until the end of the warp touches the last Harness you are using. Make them out of a strong non-stretchable linen or cotton cord. You will need to make one Extension Cord for each section in your Sectional Beam. For each Extension Cord:

- 1) Measure a piece of cord long enough to reach from the axle of the Warp Beam, at least one and a half revolutions around the Beam and then reach to the back most Harness.
- 2) When measuring the length of the cords, take into account that, when the warp is attached to the Extension Cord the knot between the cord and the warp needs to fall between the Crosspieces of the Sectional Beam, not on them. This will keep the warp smooth on the Beam so it doesn’t go over the knots created when attaching the warp to the cords.
- 3) Now double that length and cut it. All Extension Cords should be exactly the same length, so cut them all at the same time.
- 4) Take the two ends of the cord and knot them together, using an overhand knot.
- 5) Wrap the cord around the center bar of the sectional beam with a larks head knot. You will also use a larks head knot to secure the warp threads to the extension cord.

Using a Tension Box

The Tension Box is an essential tool for Sectional Warping, which:

- Puts threads under even tension.
- Spreads threads to the proper width of the section.
- Makes a thread-by-thread cross.

Sectional Beam Calculation

First, you must calculate the number of spools or cones of yarn you will need. Each section is wound onto the Sectional Beam separately; therefore, you'll need to have one spool or cone for each end in that section. For example, if your section is 2" wide, with sixteen E.P.I., you would need thirty-two spools or cones of yarn.

To prepare for Sectional Beam warping, we need to calculate:

- how many spools we need to wind
- how many yards do we need to wind on each spool
- total yardage for the project

- ***NUMBER OF SPOOLS?***

Sectional Beaming requires the use of as many spools loaded with thread per individual section as your Ends Per Inch, or planned sett in the reed, dictates.

To calculate the actual number of spools required, we need to know:

- how many EPI (this is the sett) are you going to use in the warp
- what SIZE of SECTIONS (1" or 2") will you use on the Beam

If your warp is set at 24 epi per 1", you will need 24 spools for a Sectional Beam with 1" sections or 48 spools for a Beam with 2" sections.

OF SPOOLS = EPI x SIZE OF THE SECTION

- ***NUMBER OF YARDS PER SPOOL?***

To calculate the number of yards per spool, we need to know:

- the LENGTH OF THE WARP
- NUMBER OF SECTIONS on the Beam

We calculate the number of sections by dividing the WIDTH OF THE WARP by the SIZE OF THE SECTION. If the warp width is 30" and we are using 2" sections, our number of Sections is 15.

OF YARDS PER SPOOL = LENGTH OF THE WARP x # OF SECTIONS

- ***TOTAL YARDAGE?***

If it is a single color warp or if a color sequence is repeating in each section, the same spools or cones can be used to wind all the sections needed for the warp.

TOTAL YARDAGE = # OF SPOOLS x # OF YARDS PER SPOOL

It is important to make these calculations in advance so that you can purchase your yarn in spools or cones corresponding to the amount of yardage needed on each. Sometimes this is not possible and you will need to wind your own spools from yarn that is in larger packages. For doing this, you will need empty plastic spools, a bobbin winder (preferably electric), and a yardage counter. These items are available from AVL.

Feeding The Spool Rack

Next, place a Spool or Cone Rack about five or six feet behind your loom. Place the spools or cones for the first warp sections on the Cone Rack.

Make sure you put each thread through the metal eye on the spool rack so the threads do not get tangled.

When arranging the spools on the Spool Rack, it doesn't matter whether you go top to bottom or bottom to top, the important thing is to be consistent in vertical columns and to place the spools in the order that the threads are in the warp.

Tension Box Heddle Installation Instructions

The first time you use a Tension Box, you need to install heddles on the harnesses of your Tension Box.

Your Tension Box is delivered with one bundle of one hundred heddles. These are held together with twist ties. Leave these on for now. Refer to the following diagram to familiarize yourself with the Tension Box and its parts. Push down on one of the harnesses until it stops. This causes the other harness to go up. You will use that later for making a Threading Cross. Right now we'll need to use it to help put the heddles on the harnesses.

- 1) Remove the "heddle retainer" of the harness that is up, using a phillips head screwdriver.
- 2) Notice there are four twist ties holding the heddles together. Separate the top two. Insert the top bar (of the harness that is up) into the space created by pulling apart the twist ties. Insert the bottom bar (of the harness that is up) into the space created by pulling apart the bottom two twist ties, making certain that the heddles aren't twisted. Now remove the twist ties.
- 3) Count off fifty heddles and cut the loop at the top between the 50th and the 51st heddle.

- 4) Now put the four twist ties back on the fifty heddles that were the last to go on the harness.
- 5) Remove these fifty and reattach the "heddle retainer".
- 6) Now push down on the harness that is up, making the other harness come up.
- 7) Remove the heddle retainer.
- 8) Pull apart the top two twist ties and insert the top of the harness (which is up) into the space created. Pull apart the bottom two twist ties and insert the bottom of the harness into the space created.
- 9) Reattach the heddle retainer.

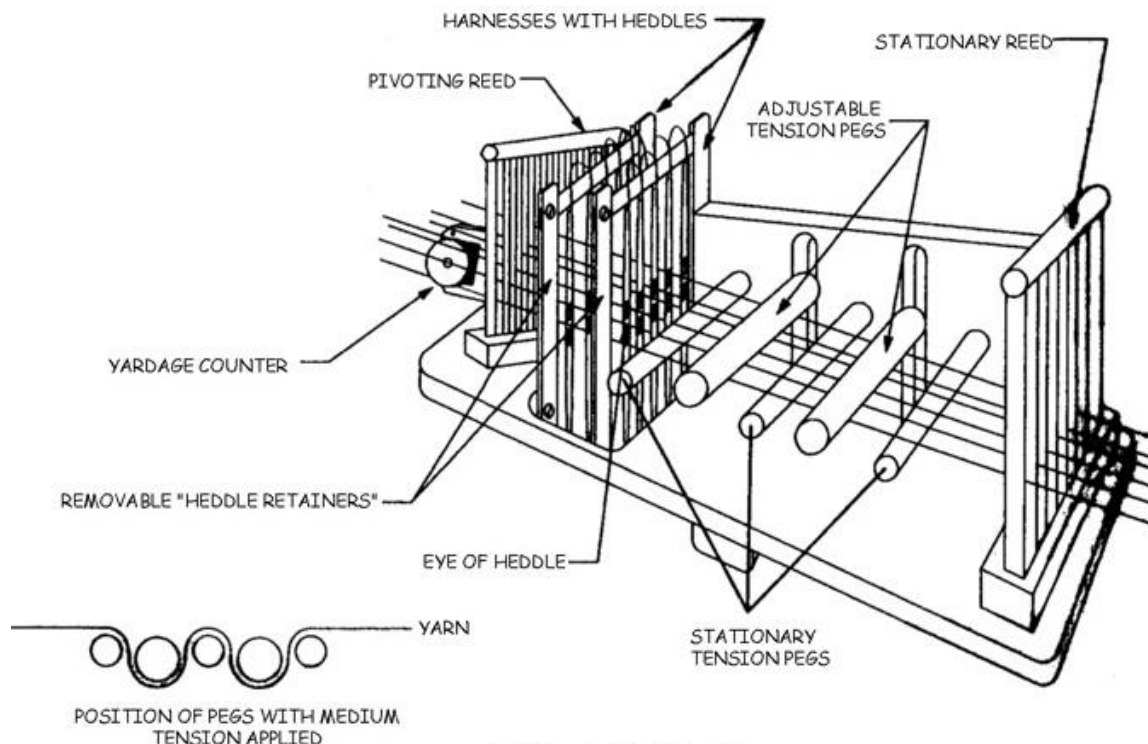

Figure 45 - Tension Box

Positioning The Tension Box

Mount the Tension Box in the groove of the tension box track, with the Counter facing into the loom. The Tension Box is attached with a small cross piece and wing nuts. This will stabilize the Tension Box and allow it to travel smoothly from one section to another. The wing nuts can be released for the Tension Box to move easily from side to side. Each time the Tension Box is

moved and centered properly for a particular section, the wing nuts must be tightened again.

Threading The Tension Box

The best way to thread the Tension Box is to take one thread from the furthest left cone (as you face the Cone Rack, with your back to the loom) and thread it all the way through all the parts of the Tension Box, nearest to the back plate of the Box, then the next thread all the way through. It works best to use the threads from the rack in a vertical order rather than a horizontal order.

Now let's go through the sequence for threading the Tension Box. First, move the two adjustable Tension Pegs up above the Stationary Pegs or remove them completely. Now, using a sley hook, draw the thread through the Rear (stationary) Reed. Since this reed is eight dents per inch, you will divide the E.P.I. into eight to find out how many ends will be in each dent (with sixteen E.P.I., put two ends in a section). If your E.P.I. does not divide equally by eight, you can either vary the number of ends in each dent (with twenty E.P.I., alternate two and three ends in the dents) or thread the dents a little wider than two inches (with twenty E.P.I., put two ends in each dent; with forty ends, the reed will be sleyed 2-1/2" wide).

Next, bring the thread straight through the Tension Peg section, between the larger adjustable Tension Pegs and the smaller, stationary Pegs or just above the smaller stationary Pegs if you have removed the larger ones.

Thread the first end through one heddle on the Front Harnesses, nearest to the back plate. The next end will go through the first heddle on the rear Harness. Repeat this, alternating harnesses for the rest of the ends. The heddle system will be used later to create the Threading Cross.

Now thread the end through the front Pivoting Reed. Here you have a choice of using an eight dent or ten dent reed. Pick the one that can be sleyed evenly and as close to the desired section width as possible. If you cannot get the exact width of the section, sley your reed slightly wider. This will make it just slightly wider than the space between the hoops. The section will be narrowed down by pivoting the Reed. Never sley the reed narrower than the section on the Beam because it is critical that the ends wind on evenly across the width of each section. If the ends are set too narrow at the Pivoting Reed, there is no way to expand it.

After the Tension Box is completely threaded, move the larger Pegs downward and tighten their wing nuts securely, to apply tension to the yarns. The further down the Pegs are moved, the more tension will be

applied to the yarn. This is an adjustable system as different yarns require more or less tension. With a heavy wool, the Pegs may only need to be moved half-way down, whereas with a fine silk, the Pegs may need to be moved all the way down and the yarn wrapped an extra time around one of the stationary Pegs to get the proper tension. Once you have adjusted the tension correctly, do not change it during the winding of the Beam, as long as you are using the same type of yarn.

Once the Tension Box has been threaded, it is not always necessary to rethread it. If you need to change spools or cones, simply tie the new ends on to the old ends just before the rear stationary reed and pull gently on the old ends until the new ends have come all the way through the box.

Winding The Warp

Before winding on the warp, check that the brake cable is in place as described on page 32. Test that you are able to turn the Beam. If this proves difficult, you can let some length out of the nylon cord by pressing on the toggle button and moving the toggle up and down on the cord. This will allow you to turn the Beam backwards during winding, while stabilizing the Beam when it is at rest. Don't forget to retighten the cord before you begin threading the heddles!

Tie an overhand knot near the end of the warp threads from one section and slip that knot into the opening of the larkshead knot you create in the Extension Cord. Pull it tight.

Line up the Tension Box to the section you will be winding.

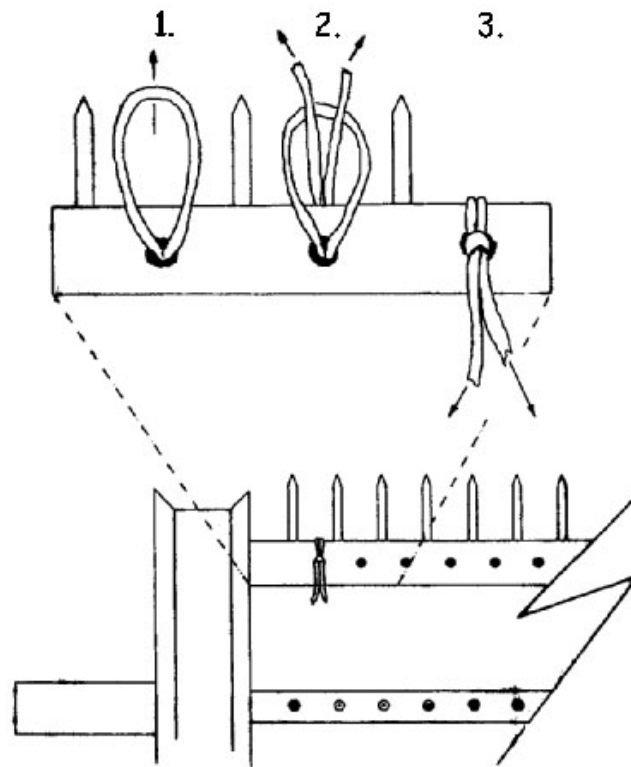

Figure 46 - Sectional Beam Extension Cords

Adjusting The Size Of The Section

Now, slowly wind about one revolution onto the Beam. As you wind, you will need to fine-tune the placement of the Tension Box along the track. When it is centered properly, tighten down the wing nuts under the Tension Box. At this point, you can pivot the "pivoting reed section" so that the yarn comes close to, but doesn't quite touch, either the hoop to the left or the hoop to the right. Now tighten the wing nut under the pivoting reed. This shouldn't need to be readjusted unless you are using a different yarn size in another section.

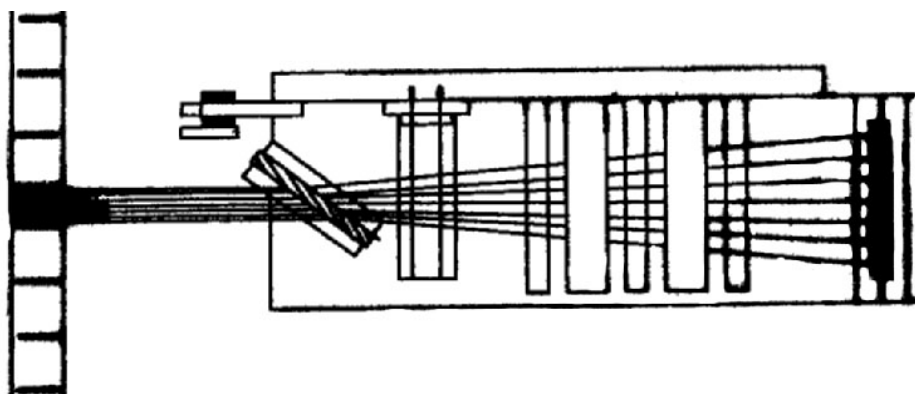

Figure 47 - Adjusting the size of the section

Extra care to correctly center and adjust the width of each warp section will result in more perfect tension while weaving.

Make sure that the threads are going on to the beam in flat layers. If you notice that warp piles up at the pegs, the section of the warp is too wide. If the warp falls down at the pegs, the warp section is too narrow.

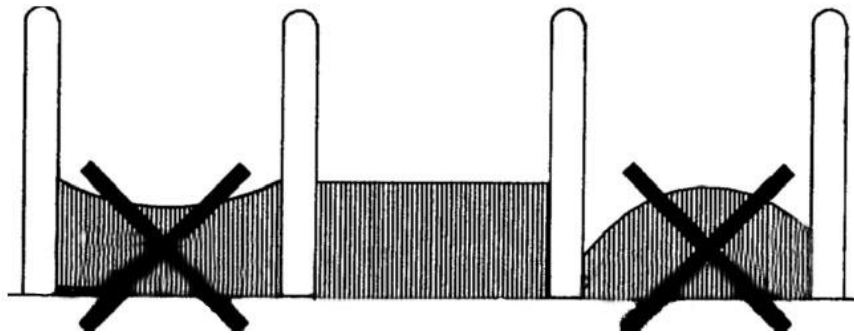

Figure 48 - Adjust the width of the section

If any of the above is happening, gently unwind the warp (into a box, perhaps) and pivot the front reed on the Tension Box again until you get perfectly flat layers. This is very **important**, otherwise you will end up having different length threads in one section, since the circumference of the Beam within the section is not going to grow evenly. This uneven tension will cause tension problems.

Counting Turns Or Yardage

To determine the length of the warp you are putting on the beam, you need to count either turns, revolutions, or yards.

To count turns, you can do it in your head, but it is more reliable to use a digital or mechanical revolution counter.

Counting revolutions even with a digital counter will still give the approximate warp length only, because the circumference of the beam will increase slightly with each rotation. This is called beam build up.

To count yards with a yardage counter while warping the sectional beam, you need to place the yardage counter at the front of the tension box. You should use an extra thread for measuring yardage, because if you use one of the threads from your warp section, that particular thread would have a different tension once you start weaving. The extra thread you use for measuring purposes only can be reused for each section.

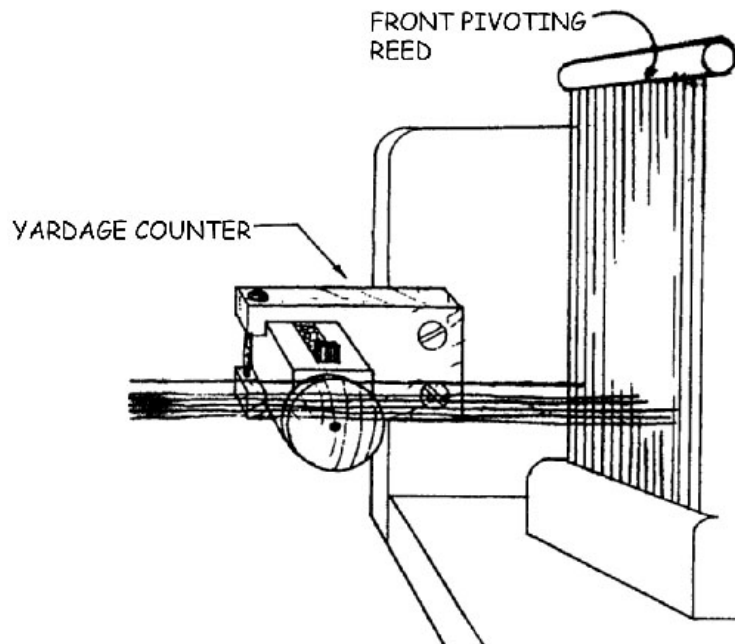

Figure 49 - Attaching Yardage Counter to Tension Box

Creating The Cross

When there is about a half yard left to be wound onto the beam, it is time to make the threading cross. Simply push on the rear heddle frame of the tension box, making half of the threads go up and the other half go down.

Now slip in an eight inch piece of contrasting thread (called a marking thread) through the opening (called a shed) created between the threads above and the threads below. Locate this marking thread about half way between the tension box and the separation roller.

Now push on the front heddle frame, making the other half of the threads go up. Now take one end of your marking thread and bring it through this shed. The two ends of the marking thread should now be together. Tie them in a bow knot. Wind the rest of the first section on, cut the ends, and secure to the wound on thread using a rubber band over the pegs.

Continue winding all the sections in the same manner by moving the tension box along its track.

Inserting Sticks In The Treading Cross

When all the winding is complete, remove the rubber bands, unwind a few feet of warp, and slip one lease stick through the path created by the upper portion of each marking tie. Now slip another lease stick through the path created by the lower portion of each marking tie. Secure the lease sticks

together, leaving about two inches between them, using masking tape or string through the end holes of the lease sticks. Now bring the lease sticks, with the warp ends, between the warp beam and the heddles so that the warp travels towards the harnesses.

Readjusting The Tension

Now tie the lease sticks from the top of the loom so that they are at eye level when you are in your threading position.

To keep the warp from slipping forward during the threading process, pull the ends of the white nylon brake adjustment cord to increase warp tension. Adjust the cord so there is a slight drag against the beam as it rotates. The final warp tension adjustment will be made later.

Using the Warping Wheel

The Setup

- 1) Adjust height so position of mini-raddle is just below eye level.
- 2) Adjust the wind-off tension with toggle and cord. Tie cord to prevent slipping.



Figure 50 - Adjust Wind-off Tension

- 3) Adjust Warp Length using different spool placement by moving the spools on the arms.
- 4) Reset the Revolution Counter to Zero.
- 5) Setup Cones with the Cone Caddy.

Making the First Section

- 6) Open and secure the raddle top using the removable pin.
- 7) Slide the thread(s) under the metal catch clip, tails facing to the left. Tails should be about 5 inches long.

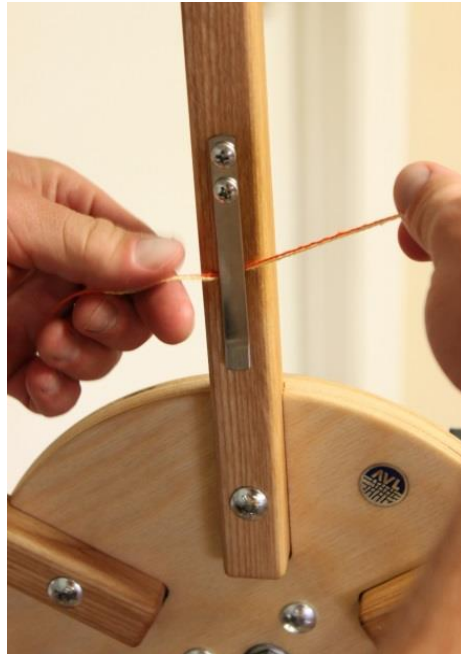

Figure 51 - Catch Thread Ends

- 8) Bring the thread(s) up and over the left side of the top spool so that you are ready to wind the Warping Wheel in a counter clockwise motion.



Figure 52 - Wind Counter Clockwise

- 9) After you have wound one length bring the thread(s) around the back of the raddle and through a dent (working from right to left).

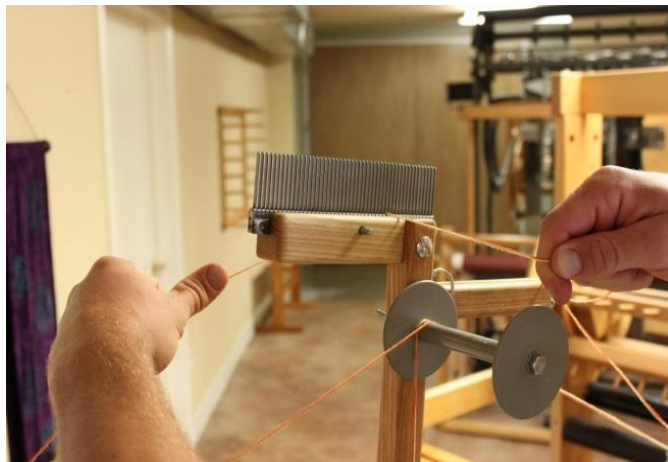

Figure 53 - Bring Thread Through Raddle

- 10) Bring thread(s) down over the end you just wound and secure in the silver clip (swooping under from left to right).

Tying Off

- 11) Put the raddle top back on. Cut the bout threads just to the left of the clip and under the threads going over the wheel.
- 12) Hold onto the threads securely at the raddle (so they don't slip through). Below, wrap the cut threads around the clip.



Figure 54 - Hold Threads at Raddle

- 13) With the raddle top secure, remove the pin from the raddle holder while holding onto the threads.



Figure 55 - Remove Raddle from Top Position

- 14) Bring the raddle down to the winding-on position and secure with the pin. Tie a knot in the thread past the raddle so it won't slip through.

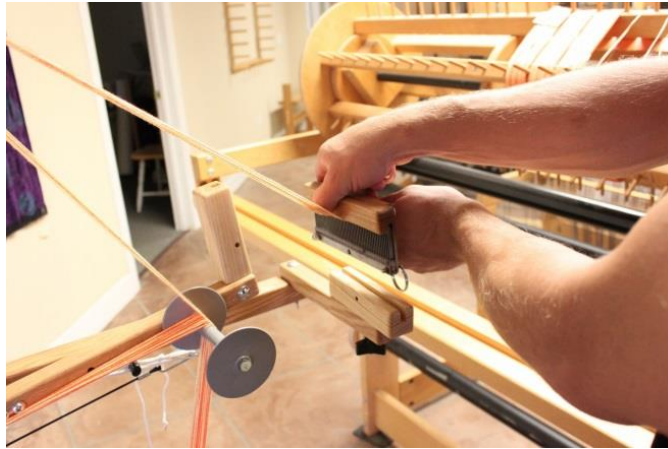

Figure 56 - Place Raddle in Lower Position

- 15) Take the extension cord from your beam. Create a larks head loop at its end and loop it around the knotted end of your warp section.



Figure 57 - Place Extension Cord Around Thread Bundle

- 16) Before the last part of the threads pass through the raddle, tape the threads on the loom-side of the raddle in their sequence using masking tape. This will help you keep the threads in order when you thread the harness.
- 17) As you wind on, pivot the raddle to adjust the width of the section to fit exactly in-between the pegs on your sectional beam.



Figure 58 - Pivot Raddle

COMBINING SECTIONAL AND PLAIN WARPING

Depending on your equipment and preferences, you may prefer to wind separate warp sections on a warping board or reel and go from there directly to the Sectional Beam. If you decide to do this, however, your warp will be limited in length by what will fit on the warping board or reel. If you choose this method, follow these steps:

- 1) Calculate the number of threads for each section on your Sectional Beam.
- 2) On the Warping Board or reel, make "baby warps" for each section on your Beam.
- 3) Make crosses at each end: raddle cross on one side and thread-by-thread cross on the other.
- 4) Take the warp off the board or reel by taking off the thread-by-thread cross first.
- 5) Put the warp threads from a first "baby" warp in the Raddle, making sure that threads are spread evenly and that they are creating flat layers when wound on the Beam. Put the raddle top on or secure warp threads with rubber bands.
- 6) Instead of a regular raddle, you can put a mini-raddle in place of the front reed on the Tension Box. In this case, the Tension Box is used only for guiding threads into the sections. It is not necessary to sley threads in the Tension Box, either through the harnesses or

- through the back reed, and you do not need to adjust tension with the Pegs.
- 7) Attach each baby warp to the Extension Cords and proceed as in regular Sectional Beaming procedure.
 - 8) Since you are not using the Tension Box for tension, be sure to keep it taut manually.
 - 9) When you come close to the end of the section, take the reed cover off and continue winding the rest of the baby warp.
 - 10) Secure that section to the Beam and continue to the next one.

If you wish to use the Tension Box to maintain tension on your warp during the Wind-On phase, it will be necessary to make a Cross at both ends of your warp. If you can make your warp slightly longer, you can use the extra length to leave in your Tension Box for the purpose of tying on the subsequent sections.

WARP ON THE LOOM

Once you have warped the warp beam properly, the warp will come from the bottom of the beam, up over the top of the beam, and into the loom. It is now ready to thread the heddles.

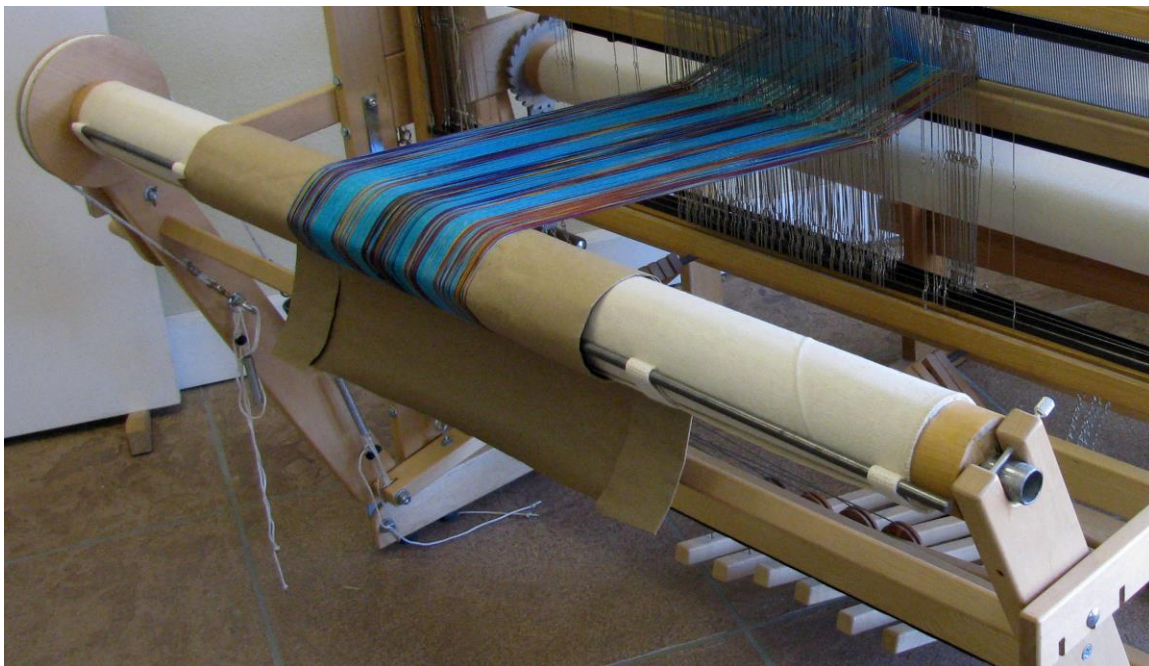

Figure 59 - Warp on the loom

THREADING, SLEYING, & TYING ON

Preparation For Threading

To prepare for threading, tie the threading cross sticks up to the rear harness pulley support with lengths of string so that the cross is in a comfortable and visible position for threading. Now cut the warp end loops (if you are using the AVL plain beam warping method) so they will be ready for threading.

The important thing in threading is your comfort. Take the time to position everything so that your body feels at ease while threading.

Lift out the beater. Remove the breast beam. Place a stool on the floor. Position yourself so that the eye of the heddle is at your eye level.

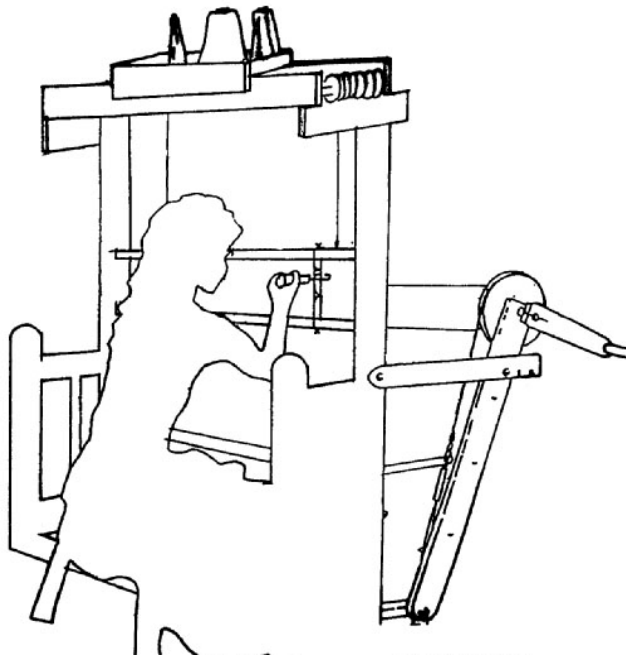

Figure 60 - Threading Position

Heddle Preparation

Choose the approximate number of heddles you wish to use. If you have planned a narrow warp, make sure you leave some heddles at the far sides of the harness sticks between the hooks and the ends of the harness sticks. For balance, there should be approximately equal numbered groups of unused heddles on both sides of each harness. In some cases, such as a very wide warp with a lot of unused heddles on the ends of the harnesses, you may need to tie each group of unused heddles into a tight bundle with

tie tapes or string to keep them from falling off the ends of the harness sticks or you may need to take heddles off the loom. What some weavers do with wide warps, in order to avoid having to take off extra heddles, is to distribute the unused heddles among the threaded heddles as the threading is taking place.

NOTE:

Another hint to make threading easier: while you have your heddles spread out, you can mark just above the eye of each heddle with a colored pen. You can use different colors of pen and mark all of the heddles on each harness with a different color. You will find that during threading, this will make it easier to tell which heddle belongs to which harness, thereby reducing the chance for threading errors. If you do choose to color code your heddles, make certain that the ink from the felt pens you use is color fast and will not wear off onto your warp material.

Threading The Harnesses

Now we're ready to thread the loom. If you are right handed, it is recommended to start at the right side of the warp. Grasp one group of ends in your left hand and your sley hook in your right hand. Direct the "hook end" of the sley hook through the "eye" of the first heddle you need to thread. Pull the thread through.

For example, if you had a straight draft on eight harnesses, your first thread would go through the eye of a heddle on the 8th harness. The second thread would be threaded through the eye of the first heddle on the 7th harness, the third thread through the first on the 6th harness, and so on.

Some weavers mark the center heddle on each harness and thread from center, out to each side. This allows for leaving an equal number of heddles at both sides of the harnesses, when threading is completed.

Unused Heddles

After threading is complete, make sure that the unused heddles are all pushed to the far sides of the harness sticks between the screweyes and the ends of the harness sticks. For balance, there should be approximately equal numbered groups of unused heddles on both sides of each harness. In some cases, such as a very wide warp with a lot of unused heddles on the ends of the harnesses, you may need to tie each group of unused heddles into a tight bundle with tie tapes or string to keep them from falling off the ends of the harness sticks or you may wish to take heddles off the loom altogether.

Note:

In the first six months of using a new loom with polyester heddles, the heddles may stretch out slightly to adjust to the harnesses.

Replacing The Beater And Sleying The Reed

Now replace the beater making sure the metal height adjuster is seated properly in the slot.

Now sley the warp ends through the reed. Some weavers start from the right side; some from the left; some in the middle. But, in all cases, be sure to measure accurately before starting so that the warp will be centered in the reed.

The AVL Home Loom comes with a pin located on the left side of the loom that can be placed through the frame of the loom and into the left beater leg, thereby holding the beater in the middle position. You may then wish to remove the top of the beater and slant the reed away from you, to further assist you in the sleying process.

Make sure the cloth beam pawl is disengaged from the cloth beam ratchet. (You'll find these at the right end of the cloth beam. When the cloth beam can move freely in either direction, then you know the pawl is properly disengaged.)

Tying Onto The Apron

Now that you have your warp ends ready to tie, we need to prepare the apron. The ends will be tied to the apron rod.

Notice that the apron has two hemmed ends. One end has loops on it and the other end has a velcro strip. The Cloth Storage Beam also has a velcro strip. Measure to find the center of the Beam and, using tape, mark the center above the velcro strip. Find the center on the apron, at the end with the velcro and fold it in half, with the velcro doubled on itself and facing out. Match center of your fold to the center of the Beam velcro, with the apron length hanging to the floor. Press the velcro strips together firmly, while pulling gently toward each side of the beam, making sure it is centered.

Now you can remove the tape marker and, turning the top of the Beam away from you, wind so the apron is wrapped once around, holding itself in place. Route the apron underneath the Cloth Beam and, towards the harnesses. Spread it out flat and center it over the Cloth Beam and insert the metal rod into the loops at the hem.

Insert the apron rod into the apron notches. Now tie the ends to the metal rod. Starting from the middle, bring a first bundle toward you over the apron rod, then around and under it. Divide it in half and bring one half up on each side of the bundle. Use the ends to tie a surgeon's knot. It is the same as the first tie you make tying a shoelace, except you loop the end twice through. This kind of knot is very good for readjusting the tension.

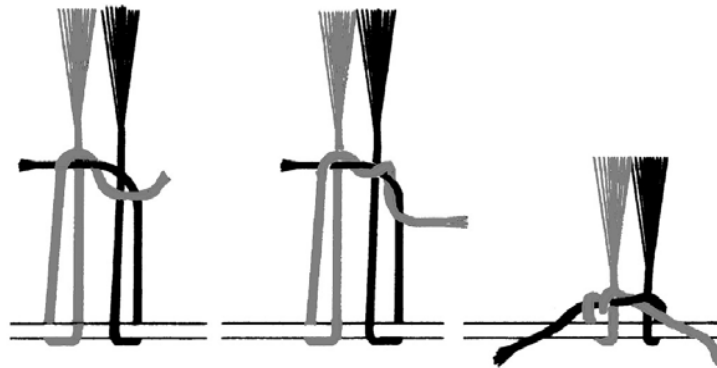

Figure 61 - Tying on

Start with one section in the middle, then the far right and the far left outside ones. Work your way in. After tying the knot, pull only until you feel some resistance and tighten the knot and proceed to the next section.

By now, the sections that were tied first maybe quite a bit looser than the ones tied last. To correct this, you do not need to untie the knots, simply grasp the ends and pull them away from you, then re-tighten the knots, remembering to only pull until you feel, what is now, a uniform resistance at each group. Repeat this until all of the sections are at approximately the same tension. It is important to remember at this point, that you are not tying to achieve weaving tension, only *uniform* tension across the width of your warp. Attaining weaving tension is what the Cloth Beam Ratchet is for!

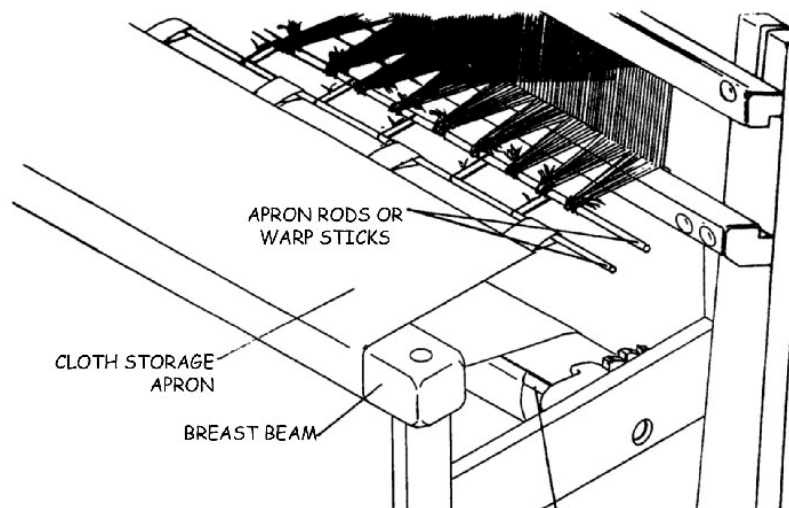

Figure 62 - Using the Cloth Storage Apron

Before adjusting the tension with the cloth beam ratchet, make sure you have adjusted the tension at the brake drum with the adjusting cord. Once the warp is attached to the Cloth Storage Beam via the apron use the handle at the right of the Beam to advance the warp and raise the tension. Simply release Warp Beam tension by depressing the Brake Pedal(s), push the handle forward to engage in the toothed ratchet, and rotate it down. It will wrap the warp onto the beam and draw the fell line away from the Beater. The Pawl is the finger device that engages in the ratchet. Its job is to keep the Beam from rolling backwards and it must be engaged to hold the tension.

Note:

If you selected the Automatic Warp Tensioning System for your loom, you will not need to depress the brake pedal to advance the Cloth Storage Beam. Simply use the handle to rotate the beam. Use the adjusting cord on the brake cable to fine-tune the tension on your warp.

Now pat the warp between the reed and the apron rod left to right and right to left. If the warp tension feels even, increase the warp tension by lifting up on the cloth beam handle until you reach the desired tension. Now pat the warp again, if it feels even, from left to right and right to left, continue to the next section. If not, release the warp tension (by stepping on the brake release pedal) and retighten the loosest sections.

Tying On To The Old Warp

A new warp can be tied on to an old warp, thus eliminating the threading and sleying process if the new warp introduced into the loom uses the same threading pattern and EPI as the last warp. This process is especially good

for production weavers, as it saves time. It also takes less concentration and there is less chance of making mistakes in threading.

The tying on process starts when you are finishing the last of the warp on the loom. Before you cut off the fabric, make sure to leave enough unwoven warp to extend one foot behind the harnesses, through the heddles, and about six inches past the reed when the beater is in its rear position. Now open two opposite tabby sheds and insert lease sticks into these sheds behind the harnesses. Secure the sticks together with tie tapes through the holes. Now carefully cut the fabric from the loom and tie bundles of warp coming through the reed together so the yarn can't slip through. Cut the warp in back (leaving one foot past the lease sticks) and also tie bundles of yarn together for security.

Now, after winding on the new warp, you can sit on a small stool placed in between the harnesses and the back of the loom and tie corresponding yarns from the two sets of lease sticks together. An overhand knot works well. This may seem slow at first, but you will work up a faster rhythm with some practice. A good goal to reach would be to tie 200 to 250 ends together an hour.

When all ends are tied together, go to the front of the loom and gently pull on the bundles of yarn going through the reed to pull the new warp through the heddles and reed. Then tie on to the apron.

HARNESSES SPRINGS

The springs of the spring lever return system should be adjusted for positive harness return, i.e., the harnesses stay all the way down in the depressed position and require the least amount of effort for lifting. This will vary according to the weight of the warp. In general, lightweight, less dense, looser tensioned warps with a smaller weaving width will need very little spring tension to assure positive harness return. Heavier, denser, tighter tensioned, and wider warps will need more spring tension.

To tell if the harnesses are returning all the way, open several sheds by working the treadles. Watch the unlifted harnesses. If the tops of their heddles become loose and tend to move around, then spring tension should be increased, but just enough to get the harnesses to stay down and no more, or your treadling effort will be made greater than it has to be.

To adjust the spring tension, simply unhook the spring and then rehook it one chain link shorter. This tightens the spring and makes it pull down

harder on that particular harness. Test the warp again by doing some more treading and if more spring tension is still needed, try one or more chain links less. Under unusual conditions (perhaps a very tight rug warp), two springs on some or all of the harnesses may be necessary. If all the springs are set the same, the back harnesses will have a looser tension than the front. This is because the back spring levers and their hooks are longer since the back harnesses travel farther when a shed is made. Accordingly, in some cases, the back spring levers might have to be adjusted shorter to give the same tension as the front ones.

The important thing to remember is that the system is designed so that it can be “fine tuned” for each particular warp, so experiment with it. In general, for most medium tensioned warps, you will find that a lot of adjusting will not be necessary.

TREADLE TIE-UP

One great feature of the AVL Home Loom is the method by which the treadles are attached to the harnesses. This is accomplished by the use of the Side Tie-Up system, which eliminates the need to crawl under the loom to obtain various treading combinations. All treadle to harness tie ups are accomplished at the side of the loom by connecting tie up cables to metal clips. Virtually any harness can be hooked up to any treadle. Several side tie-up cords have been included with the loom so you can set the loom up as you see fit.

If you look closely at these cords, you will see that they are made of a series of loops. To maintain a proper shed configuration, make sure that you always use the end loop at each end of all cords. (In some instances, you may receive special instructions with your tie-up cords that ask you to do otherwise.)

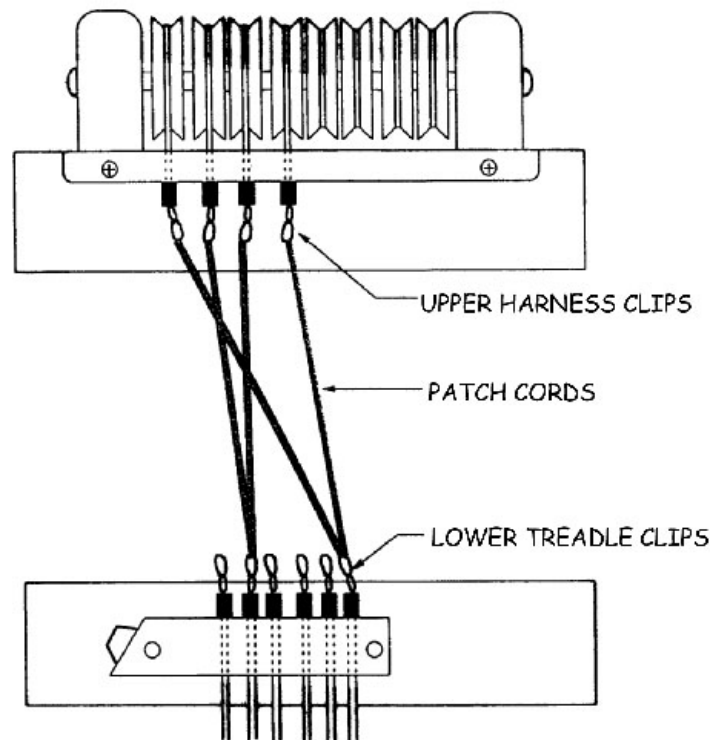

Figure 63 - Home Loom Tie-up

On the right side of the Home Loom that there are two sets of clips: A lower set of treadle clips and an upper set of harness clips. First tie up your loom for a tabby weave as tabby weave will always be used for the first couple of inches of each new warp as a heading. It is easiest to make all treadle connections first and then all of the harness connections. For a tabby weave using four harnesses, first connect the two patch cords to each of the two adjacent treadle clips, then connect the two patch cords from one treadle clip to the clips for harnesses one and three. Next, connect the two patch cords from the other treadle clip to the clips for harnesses two and four.

With more complex weaves using four treadles or more, it is helpful to use a "walking" technique for the treading. Using this method, the tie up is made so that treading begins at the two innermost treadles and you can "walk" to the outside treadles using alternate foot movements. With this method, you never lift more than one foot at a time and thus are not thrown off balance and it is easy to establish a weaving rhythm (so important for speed and uniformity in the cloth). You will have to rearrange conventional tie up plans which read from left to right in order to do this.

WEAVING

With everything properly adjusted, weaving is an easy and enjoyable process. Sit up straight and comfortably at the loom so that your body remains stationary while your arms and legs work the loom. Simply press down on the treadles in the sequence determined by the pattern of your weaving. Now throw the shuttle. Catch the shuttle with the opposite hand, then pull the beater forward with a quick wrist movement while closing the shed.

Advancing The Cloth

To advance the cloth, you simply put the beater in its forward position (toward you), depress the brake pedal, and pull up on the cloth beam handle until the fell of the cloth is about three inches from the breast beam. Now let go of the brake pedal and continue winding up the cloth beam handle until the desired tension is reached.

Threading Error

In case of a threading error, use the following method for insertion of a new polyester heddle:

- 1) Remove the harness wire from the nearest end of the harness and slip the top loop of the new heddle around the top harness stick and bring it through the top loops of all the heddles until it reaches the place needed.

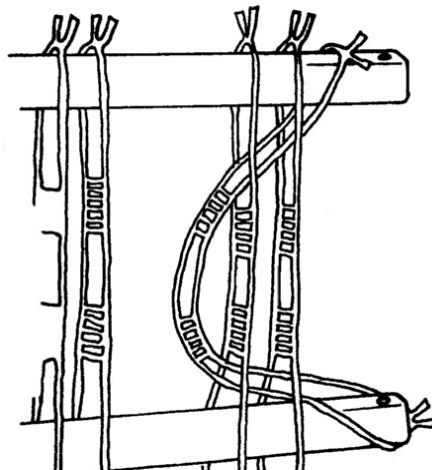

Figure 64 - Insertion of a new heddle

- 2) Take the bottom of the new heddle through the bottom loop of all the heddles, around the bottom harness stick, and back through the bottom loops of all the heddles until it reaches its place.
- 3) Replace the harness wire.

Starting Weaving

At the onset of weaving, first weave in one inch of a strong, medium weight weft with a tabby weave. Check the tabby weave for errors. Any errors in the threading or sleying will show up here and it is an excellent time to make corrections. Then weave in two thin lease sticks on alternate sheds followed by another 1/2" of tabby weave. Cloth strips should not be necessary as the two woven in lease sticks will even out the warp for you. Now change the Home Loom tie-up, if so desired, and proceed with your planned weaving.

Sample Weaving

For sample weaving, if you wish to remove part of the weaving from the loom before the entire warp is woven off, use the following procedure:

- 1) When the piece to be removed has been woven, weave one inch of tabby.
- 2) Weave in two lease sticks followed by 1/2" of tabby.
- 3) Start new weaving and weave until the lease sticks are wound 1 1/4 times around the cloth beam (or about 18").
- 4) Unwind and cut off the piece to be removed just below the tabby hem and woven-in lease sticks as above.
- 5) Place the two woven in lease sticks flat on the front cloth beam making sure they are centered and parallel to the roller.
- 6) Wind the weaving back on the cloth beam holding the lease sticks in place until the weaving winds back over itself and holds itself in place. Take up the tension by using the ratchet handle.



ADDITIONAL LOOM INFORMATION

LOOM MAINTENANCE

Lubrication

The AVL Home Loom has been designed and built to deliver many years of trouble free service. A minimal amount of maintenance will be required to insure that your loom will continue to perform properly. The arrows show the points on the loom which should be oiled occasionally. Any light grade lubricant, such as sewing machine oil, WD-40, or Tri-Flow teflon lubricant can be used. Make certain that you never lubricate the brake cable or cord, especially where it makes contact with the brake drum as this can cause tension problems.

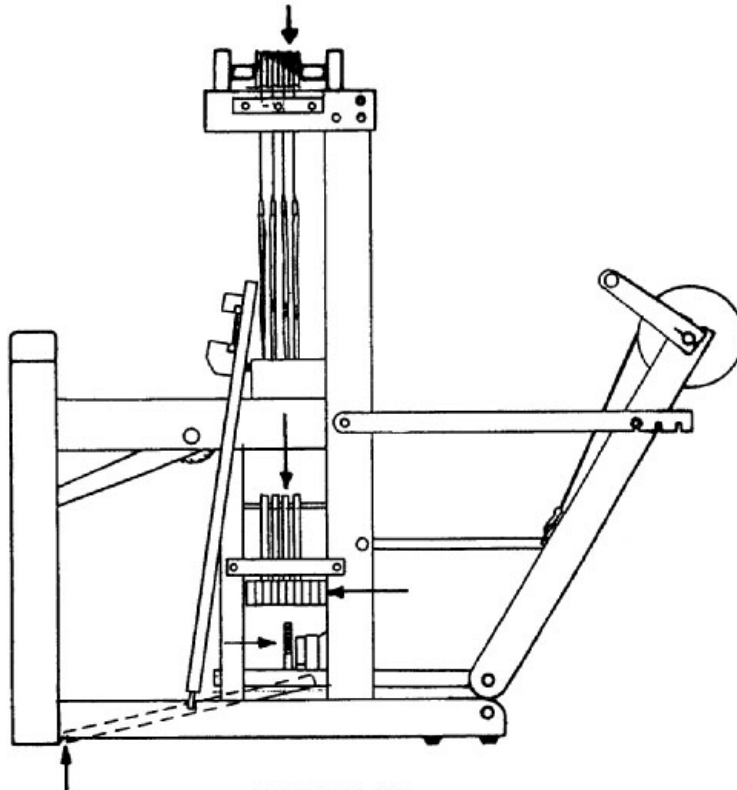

Figure 65 - Lubrication Points

Tightening The Bolts

The single most important thing you can do to extend the life of your loom, and preserve its operation, is tighten the bolts that hold its frame together. These will loosen over time, due to changes in its environment and to your own creative exertions.

Lubrication And Cleaning

There are several mechanisms on your loom which will benefit from the occasional light application of an appropriate lubricant. Not all lubricants are suitable in the weaving environment. Machine oils and greases, for example, can capture yarn dust and will, over time, actually impede the action of your loom.

Loom Parts	Lubrication and Cleaning
Shuttles, Shuttle Race	Paste Wax
Axles (pulleys, spring levers, overhead beater)	Silicon Spray
Warp Beam Metal Rods (where metal works against the wood frame)	Paraffin
Warp Beam Brake Drum	Sandpaper

Checking Cords And Cables

The cords and cables on your loom will wear out due to the friction of the moving parts. Check all cords and cables for wear and replace as needed.

Brake Cable

If you remove the Brake Cable, please be sure, when you reinstall it, that the looped end is secured to the "J" bolt, that the cable is drawn immediately up from this bolt and around the back of the drum (x3), and that it then routes down the front of the drum where it connects to the adjustment cord at the pedal. Be sure the cable does not cross over itself at any time.

Swinging Beater

You can square (or "rack") the swinging beater by loosening the four bolts that attach it to its arms. Bring the beater fully forward and retighten the bolts, while holding it firmly in place. You must have a reed in place on the Swinging Beater to make a good adjustment.

The height of the Beater can be adjusted as well, by turning the three-pointed Knob mounted to the bracket on the Beater Support, to raise or lower the support. You may wish to use a small level to ensure that you have made equal adjustments to both sides of the Beater.

Tool Kit And Spare Parts

Here's a list of the basics, nice-to-have-around items:

1) Minimum Tools

- Socket Wrench with
 - 7/16", 1/2", 9/16" socket
- 6" or 8" Crescent Wrench
- Medium Standard Blade Screwdriver
- 4-1 Screwdriver or Medium Phillips and Standard Screwdrivers
- 1/8" Allen Wrench
- Level
- Paste Wax
- 0000 Steel Wool Pad
- 220# Sandpaper
- Paraffin Wax

2) Spare Parts You Might Consider Having

- Spare Treadle Cable
- 6' length of 350# Braided Dacron
- Cord (for emergency repairs)

TROUBLESHOOTING

The AVL Home Loom, by design, is simple and uncomplicated. You should experience very few problems with it. If you do experience any difficulty, consult the following troubleshooting chart. If the problem persists, do not hesitate to contact an AVL service representative for additional assistance.

Troubleshooting Chart

PROBLEM	REASON	SOLUTION
Too many harnesses raise.	Incorrect tie up.	Check side tie up cords.
	Tie up cords tangled.	Untangle cords.
	Harnesses hanging up on each other.	Untangle harnesses from each other.
Not enough harnesses raise.	Incorrect tie up.	Check side tie up cords.
	Broken tie up cord.	Replace cord.
	Broken or misrouted treadle cable.	Check cables.
Shed not large enough.	Beater adjusted too high.	Lower beater.
	Cloth too close to harnesses.	Advance warp.
	Unlifted harnesses "floating" or not being held all the way down.	Tighten spring lever at adjusting chain. Reduce warp tension.
Harnesses catch on one another.	Heddles catching on adjacent harness.	Spread out bundled heddles. Increase spring lever tension.

PROBLEM	REASON	SOLUTION
Heddles fall off end of harness sticks.	Heddles too close to end.	Move heddles inward. Remove extra heddles. Increase spring lever tension. Tape last heddle in place on harness stick.
Brake not holding tension.	Incorrect adjustment.	Tighten adjusting cord.
	Brake drum glazed or oily.	Remove cable and clean drum and cable.
	Spring worn.	Repair or replace spring.
Brake not releasing tension.	Incorrect adjustment.	Loosen adjusting cord.
	Dirty brake drum.	Clean drum and cord.
	Cord crossed on drum.	Check routing of cord.
Loom squeaks.	Needs lubrication.	Check lubrication chart.
Treadles difficult to operate.	Lifting large number of harnesses.	Lubricate loom. Reduce spring lever tension if possible.
	Harness or treadle cables routed improperly.	Check routing of cables. Make sure all cables are on pulleys.
Large warp build up alters shed size.	Folding legs need adjustment.	Adjust folding legs so that they are being held in the outer or center slots on the support arms.

THE FINE PRINT

AVL CUSTOMER SERVICE

AVL offers free technical support to the original owner of all our looms. This means if you ever have a problem, you can call, fax, or e-mail us and we'll help you find a solution. Please take advantage of this service; your satisfaction is extremely important to us.

Customer Service Phone: (530 893-4915)

Fax: (530) 893-1372

E-Mail: sales@avlusa.com

AVL WARRANTIES

Limited Warranty: The benefits of this warranty accrue solely to the original purchaser of AVL Looms, Inc. products, as defined below.

Your warranty covers:

New Looms: AVL Looms, Inc., a California corporation ("AVL") warrants to the original purchaser of any AVL loom (each, a "Product") that the Product will be free from defects in materials and workmanship during the limited warranty period described herein. The limited warranty coverage begins (a) the day the Product is installed if installed by a professional from AVL, or (b) on the date of shipment from AVL to the original purchaser if the Product is not installed by AVL (the "Effective Date"). Except as set forth under the section entitled "What is Excluded?" below, AVL will, for a period of two (2) years from the Effective Date (the "Original Warranty Period"), repair or replace the defective part(s) of the Product with a repaired, renewed, or comparable part (whichever is deemed necessary or proper by AVL) if it becomes defective or inoperative or fails to perform according to AVL's specifications. Any repair during the Original Warranty Period will be carried out without charge to you for parts (except applicable taxes, if any). You will be responsible for all labor in connection with installation of the parts and service upon the Product, as well as the cost of shipping involved.

New Accessories, Loom Upgrade Parts, and Replacement Parts: Subject to the limitation contained in subsection (i) under the section entitled "What is Excluded?" below, AVL warrants to the original purchaser of any accessory, loom upgrade parts, or loom replacement parts (the "Additional Part") that are sold by AVL that such Additional Part will be free from defects in materials and workmanship for ninety (90) days from the date of purchase. In the event that any Additional Part is physically damaged or physically defective and if such defective Additional Part is returned to AVL within ninety (90) days of the date of purchase, AVL will provide a replacement Additional Part at no charge. The sole remedy for this warranty shall be limited to the replacement of the defective Additional Part. You are responsible for all shipping charges (including applicable taxes) incurred with returning the defective Additional Part.

All New Products and their components (including replacement Product and its components) are covered only for the Original Warranty Period. When the warranty on the original Product expires, the warranty on any replacement Product, or components also expires. After two (2) years from the Effective Date, you pay for any replacement or repair, including all parts, all labor and shipping charges (including applicable taxes).

Your warranty does not cover:

- 1.Labor charges for installation or set-up of the Product, as well as any labor charges required to install, disassemble, troubleshoot, or reassemble the Product.
- 2.Any taxes imposed on AVL for Product replacement or repair under this warranty.
- 3.Installation, performance of, or repair of: cabling, electrical, or accessory attachments used with the Product.
- 4.Product replacement or repair because of misuse, accident, repair by any party other than AVL, or other cause not within the control of AVL. Please note that removing any parts from the Product for any reason voids the warranty.
- 5.Incidental or consequential damages resulting from the Product.
- 6.A Product that has been modified or adapted to enable it to operate in any country other than the United States or any repair of Products damaged by these modifications.
- 7.Electrical and pneumatic components, each of which carries a one (1) year warranty from the Effective Date.
- 8.Jacquard components function beyond 98%. A Jacquard module is considered to be operating within specification if 98% of all hooks are operating as commanded.
- 9.Computing equipment, such as a Personal Digital Assistant or a Personal Computer, which are manufactured by a third party(ies) and which may be under warranty through the original manufacturer. AVL is not responsible for any warranty coverage that may be offered concerning these products and you must contact those manufacturers directly regarding any available warranty coverage.

The performance or functionality of any software that is sold either together or separate from the Product. The AVL warranty covers only defects in the Software Media, namely the CD-ROM media such as a broken CD-ROM or a defect in the CD-ROM that would prevent the CD-ROM from being read by your personal computer's CD-ROM drive. ,

AVL Returns Policy

Any order that has left AVL in transit to the customer is considered fulfilled. Parts and accessories not covered under warranty must be returned to AVL within 60 days from the date of shipment from AVL. The purchase price of the item(s) is refundable less a 15% re-stocking fee based on the total purchase price. No refunds will be given on shipping or handling. The buyer is responsible to return the merchandise in "as new" condition at their expense. Any item received showing wear or damage is not eligible for return and will be promptly returned to the customer COD unless some other arrangement is made. Looms and custom-made items, special order items, parts made for pre-1998 looms, used and reconditioned items are not eligible for return.

NOTICE TO USERS IN THE EUROPEAN UNION

Products bearing the CE mark are in conformity with the protection requirements of EC Council directives 2004/108/EC, 2006/95/EC, 1999/5/EC, and 2009/125/EC on the approximation and harmonization of the laws of the Member States relating to electromagnetic compatibility, safety of electrical equipment designed for use within certain voltage limits, radio equipment and telecommunications terminal equipment and on the ecodesign of energy-related products.

Compliance is indicated by the CE marking.



The manufacturer of this product is: AVL Looms, Inc., 2360 Park Avenue, Chico, CA 95928 USA. A declaration of conformity to the requirements of the Directives is available upon request from the Authorized Representative. This product satisfies the Class B limits of EN 55022 and safety requirements of EN 60950.



CERTIFICATE & DECLARATION OF CONFORMITY FOR CE MARKING

Company contact details:

AVL Looms, Inc., 2360 Park Avenue, Chico, CA 95928, USA
Tel: 530-893-4915 Fax: 530-893-1372

AVL Looms, Inc. declares under their sole responsibility that their:
Textile Producing Looms listed as follows

A-Series Looms with the following part numbers:

A30-8H-CD4, A30-16H-CD4, A30-24H-CD4, A30-32H-CD4-E, A30-40H-CD4-E, A40-8H-CD4, A40-16H-CD4,
A40-24H-CD4, A40-32H-CD4-E, A40-40H-CD4-E, A48-8H-CD4, A48-16H-CD4, A48-24H-CD4,
A48-32H-CD4-E, A48-40H-CD4-E, A60-8H-CD4, A60-16H-CD4, A60-24H-CD4, A60-32H-CD4-E,
A60-40H-CD4-E, A72-8H-CD4, A72-16H-CD4, A72-24H-CD4, A72-32H-CD4-E, A72-40H-CD4-E

V-Series Looms with the following part numbers:

V30-16H-CD4-E, V30-24H-CD4-E, V30-32H-CD4-E, V30-40H-CD4-E, V40-16H-CD4-E,
V40-24H-CD4-E, V40-32H-CD4-E, V40-40H-CD4-E

SDL looms with the following part numbers

2010, 2030, 2010-30, 2030-30

(where the 2010 is a 20" weaving width with 16 frames, the 2030 is a 20" weaving width with 24 frames,
the 2010-30 is a 30" width with 16 frames and the 2030-30 is a 30" width with 24 frames)

Workshop Dobby Looms with the following part numbers:

3010, 3020, 3030, 3040, 3050, 3060 (where the 3010 is a 16" weaving width with 8 frames, 3020 is 16" with 16 frames,
3030 16" with 24 frames, 3040 is 24" with 8 frames, 3050 is 24" with 16 frames and 3060 is 24" with 24 frames)

comply with the Essential Requirements of the following EU Directives:

Machinery Directive 2006/42/EC Low Voltage Directive 2014/35/EU EMC Directive 2014/30/EU
Radio Equipment Directive 2014/53/EU RoHS 2 Directive 2011/65/EU

and further conform with the following EU Harmonized Standards as applicable:

EN ISO 11111-1:2016 EN ISO 4414:2010 EN 60204-1:2006 + A1:2009
EN 61000-6-3:2007+A1:2011 EN 61000-6-1:2007 EN 300 328 V2.1.1

Dated: 16 June 2017 **Position of signatory:** President **Name of Signatory:** Theodore Kruger

Signed below:

on behalf of AVL Looms, Inc.