

# Installation and User Manual

## E-Lift™ version 3



AVL Looms  
2360 Park Avenue, Chico, CA 95928-6785 U.S.A  
www.avllooms.com | sales@avlusa.com  
530 893-4915 (ph) | 530 893-1372 (fax)

# Table of Contents

Table of Contents	2
INTRODUCTION	3
Support and Warranty	3
Safety	4
Package Contents	5
Tools	5
Definitions	2
The “Switch”	2
E-Lift Weaving Modes	2
Orientation	2
Acronyms	2
INSTALLING THE E-LIFT	7
A-Series, PDL & TDL Looms	7
SDL & V-Series Looms	13
OPERATING THE E-LIFT	19
MAINTENANCE AND REPLACEMENTS	21

## INTRODUCTION

Congratulations on your purchase of the E-Lift system. The E-Lift does all the hard work of opening and closing the shed. You just press the switch and weave! The assistance this system provides eliminates the physically tiring action of treading, reducing leg strain and fatigue. The E-Lift even enables weaving where it might otherwise be too difficult for persons with mobility issues.

Version 3 of AVL's E-Lift is the first design using closed loop operation, which simplifies both installation and operation of the E-Lift. No more crawling on the floor to set the starting position, just press and hold the foot switch for optimal positioning.

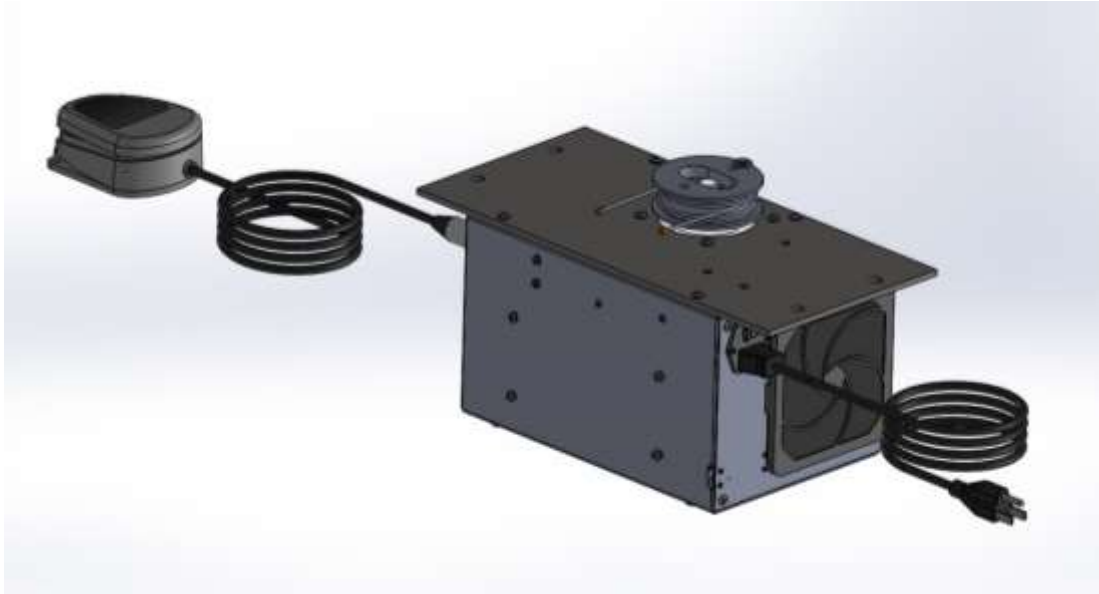

### Support and Warranty

Your new E-Lift is designed to provide years of dependable service. It comes with a lifetime of phone and email support and a standard AVL one year warranty for the original owner. Want to discuss the warranty in more detail, or get support for your AVL product? Please contact AVL at 530-893-4915 or by email to [support@avlusa.com](mailto:support@avlusa.com).

BEFORE GETTING STARTED: PLEASE READ THE ENTIRE MANUAL BEFORE USING THE LOOM.

## Safety

### Warnings:

EQUIPMENT SHOULD ONLY BE USED FOR TEXTILE MANUFACTURING. IF THE EQUIPMENT IS USED IN A MANNER NOT SPECIFIED BY THE MANUFACTURER, THE PROTECTION PROVIDED BY THE EQUIPMENT MAY BE IMPAIRED.



ELECTRICAL SHOCK HAZARD. DO NOT TAMPER WITH ELECTRICAL WIRES OR OPERATE E-LIFT WITH SAFETY PANELS OPENED OR REMOVED.



PINCH AND CRUSH HAZARD. DO NOT PLACE HANDS IN MOVING MECHANISMS.



EQUIPMENT IS HEAVY. TO AVOID MUSCLE STRAIN OR INJURY, USE PROPER LIFTING TECHNIQUES AND A HELPER.

USE OF CONDUCTIVE FIBER OR YARN ON OR AROUND THIS EQUIPMENT WILL VOID WARRANTY AND MAY DAMAGE EQUIPMENT.

THIS EQUIPMENT IS CLASSIFIED FOR HOME USE ONLY.

## Package Contents

We strive to package our products with care to ensure that they arrive intact and undamaged. Even with our best efforts, issues can occur during shipping. It is important for you to inspect and verify the completeness of your order as soon as it arrives. Please inspect the outer package for damage, take pictures and immediately report any significant concerns to AVL. Once you are ready to open the package, please carefully remove all contents from the packaging and verify that all parts, hardware arrived. Your package should contain:

- E-Lift system (1) with attached:
  - Motor lifting cable (1) with clip retainer (1)
  - Motor return cables with spring (1) with clip retainer (1)
- Mounting blocks (2)
- Cam-cylinder assemblies (2) secured in mounting order, including:
  - Lifting cam-cylinder with dobbie to cylinder lifting cable (1) & clip retainer (1)
  - Lowering cam-cylinder with dobbie to cylinder lifting cable assembly (1) & clip retainer (1).  
NOTE: The dobbie to lowering cylinder assembly consists of two cables and a small extension spring joining the cables.
  - Spacers – Each configuration uses different quantity and size of spacers which are provided in mounting order.
  - Stop collars - Each configuration uses different quantity and size of stop collars which are provided in mounting order.
  - Axle bushings (4) - Older looms (ONLY) used a 1/2" axle and require axle bushings in each end of the cam-cylinders to adapt from their 5/8" diameter holes.
  - 1/2" stop collar (1) - Older looms (ONLY) use axle caps on the outside ends to retain the axle in the side frame. You will be removing the rear or right side axle cap which is destructive to the axle cap. The stop collar replaces the axle cap. An Allen wrench for the stop collar is provide in the hardware pack.
- Foot or hand switch with cord (as ordered) (1)
- Power cord (1)
- Hardware pack, includes:
  - Mounting hardware for E-Lift and mounting blocks
  - Allen wrench for 1/2" ID stop collar (where applicable)
  - Allen wrench for 5/8" ID stop collar (where applicable)

## Tools

- 7/16" & 1/2" wrenches
- 7/16" & 1/2" sockets with wrench
- Phillips head screwdriver
- Needle nose pliers

- Drill motor
- 11/32" drill bit
- Tape measure
- Pencil
- Ferule crimping tool (Pre-1988 PDL & TDL looms only)

## Definitions

### The "Switch"

- An electrical switch selection is how the user communicates with the E-Lift.
- The standard configuration for the E-Lift includes a foot switch for operating the E-Lift. There is also an option for a hand switch that is mounted to the beater top.
- Because the switches manage the same function, this document will simply refer to them as the "switch".
- There are two types of switch selection actions:
  - Quick on/off selection (for normal weaving operation), or
  - Press and hold selection (for Homing or changing Modes).

### E-Lift Weaving Modes

- Double-shed Mode
  - Double-shed mode is an operating mode where the ending movement is always with an open shed, or if no harnesses are selected where the slide plate or dobbie arm are in the down position.
  - Double-shed is the default Mode whenever the E-Lift is powered on.
  - Double-shed is the most efficient Mode for weaving
- Single-shed Mode
  - In Single-shed Mode operation, each switch selection moves the slide plate or dobbie arm to the next position.
  - Single-shed can only be accessed by changing Modes.
  - Single-shed is intended primarily for aiding in loom or warp diagnostics.

### Orientation

For physical orientation while at the loom, all directional references are relative to the sitting weaving position (i.e. the *front of the loom*).

### Acronyms

FDL – Folding Dobby Loom; folding frame loom in production bet. 1981-2008  
 PDL – Production Dobby Loom; full frame loom in production bet. 1977-2002, predecessor to the A-Series loom

SDL – Studio Dobby Loom; small frame loom orig. 1992, shares basic frame with the V-Series loom

TDL – Technical Dobby Loom; full frame loom in production bet. 1988-2002, predecessor to the A-Series Loom

## INSTALLING THE E-LIFT

Each loom type may have a different details for its installation procedure. Please refer to the loom specific notes where identified in these instructions.

### A-Series, PDL & TDL Looms

Note: If you are replacing an existing E-Lift 2 or 2+ steps 1a, 1e, 2 and 3 can be skipped. The E-Lift 3 directly replaces the E-Lift 2 & 2+ with the additional step of removing the return spring lever and spring from the rear treadle crossmember.

1. Preparing the loom:
  - a. Lightly mark in pencil each treadle pulley support cross member for correct positioning, with reference to front/back and up/down, before removing them from the loom. Also, lightly mark the dobbie arm in pencil with an “R” for which hole is used with the cable to the cam-cylinder, and with an “L” for which hole is used with the cable to the left treadle.
  - b. Disconnect the treadle cables at the treadles. Remove the treadles, treadle support mounting blocks and axles from the loom.
  - c. Disconnect both cables from the slide plate or dobbie arm. On older looms (pre-1988), dobbie arm cables are crimped in place and must be cut to remove them. On newer dobbie arm-equipped looms, black plastic cable retainer buttons are used in the dobbie arm to retain the cables. The buttons are removed from the opposite side as the cable entry hole by pushing the cable further into its entry hole. Retain the buttons for later use.
  - d. Remove the cam-cylinder and single pulley from the loom by removing the rear stop collar or axle cap, sliding the axle towards the front of the loom and partially out of the rear vertical side frame member until the cam-cylinder and single pulley are free to be removed. Remove them now along with the cables attached to the cam-cylinder.
  - e. Remove the treadle pulley support cross member assembly from the loom. Once off the loom, disassemble it by removing the treadle pulley axles and pulleys from the cross members.
2. Drilling the cross members: With the cross members located on a workbench or other suitable working surface, drill the holes required, as shown in Figure & Chart 1.

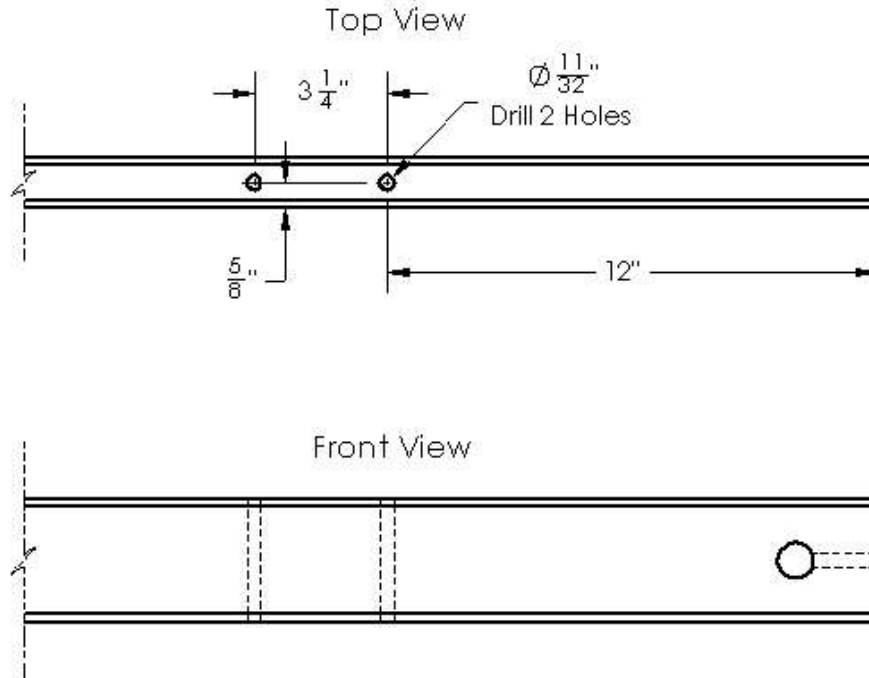

Figure 1 – A-Series, PDL & TDL Treadle Pulley Support Cross Members (Front and Rear) Holes

HOLE NO.	CROSS MEMBER	HOLE SIZE	HOLE ORIENTATION	DISTANCE FROM EDGE
1	front	11/32"	vertical	12"
2	front	11/32"	vertical	15 1/4"
3	rear	11/32"	vertical	12"
4	rear	11/32"	vertical	15 1/4"

Chart 1 – A-Series, PDL & TDL Cross Member Hole Information

3. Reinstall the cross members, remembering to align them as before.
4. Mounting the E-Lift.

NOTE: There is some variation in mounting by loom age with the PDL.

- a. Orient the E-Lift so that the power switch faces to the rear of the loom and the round switch receptacle faces the front of the loom.



- b. Position the E-Lift under the treadle pulley support cross members to align the holes in the E-Lift mounting plate with Holes 1, 2, 3, & 4.
  - c. The Motor Box is heavy. It is recommended that two people lift the E-Lift into place while a 3rd person installs the mounting blocks and hardware. Or, use 2 pieces of 2”Tx4”Wx~6-12”L placed on edge under the bottom of the E-Lift housing to elevate it into position while getting the bolts and blocks in place.
  - d. All Looms, except for pre-1988 Production Dobby Looms:
    - i. Insert one 5/16-18” x 6 1/2” hex bolt and flat washer into the #s 1, 2, 3 & 4 holes from the top down, letting them hang with the exposed ends pointing to the floor.
    - ii. Insert a mounting block onto a set of bolts in line with the cross member, engage the bolts in the corresponding holes in the E-Lift mounting plate, and then loosely install a flat washer, lock washer and hex nut on each hex bolt.
    - iii. Repeat with the other set of bolts, adding the mounting block, E-Lift and remaining flat washers, lock washers and hex nuts.
    - iv. Tighten the mounting hardware.
  - e. Pre-1988 Production Dobby Looms:
    - i. The above procedure applies to the front 2 mounting holes and mounting block.
    - ii. Due to narrower dimensions of the cross member spacing, the rear mounting on the E-Lift is closer to the front mounting. The rear mounting hex bolts are screwed directly into threaded holes in the top of the E-Lift top plate.
    - iii. Ensure that the lock washer and flat washer are applied to the bolt head side of the rear hex bolts.
5. Installing the cam-cylinders and coated steel cables:
- a. Installing cam-cylinders – E-Lift 3 comes with two cam-cylinders, one for lifting harnesses and one for lower harnesses.
    - i. Measure the diameter of your cam-cylinder axle. If it is 1/2” you will use 4 bushings inserted into each side of each new cam-cylinder in order to match the axle sizing. Otherwise, omit the 4 bushings in the package.
    - ii. Find the configuration for your loom in the following Figure 3 images. Slide the “lifting” cam-cylinder, “lowering” cam-cylinder, spacers and stop collars onto the axle as indicated for your loom’s configuration. Do not tighten the stop collars.
    - iii. Slide the axle back into place in the rear vertical slide frame member and secure with a stop collar.
  - b. Aligning the cam-cylinders – The cylinder portion of each cam-cylinder is designed with a length to establish a direct route for its cables with as little angle as possible.
    - i. Before alignment, lubricating the cam-cylinder axle is recommended. Beeswax is a long-lasting lubricant that is rubbed directly onto the axle under where the cam-cylinders will operate. A dry, clear, spray Teflon or Silicone lubricant is also suitable, though it provides less longevity.
    - ii. Align the lifting cam cable path by line of sight with the left side of the E-Lift motor pulley. The cable should be straight on between the cam and motor pulley with minimal angle.

- iii. Align the lowering cam cable path by line of sight with the right side of the small stand-off pulley mounted to the top of the E-Lift plate. This is the path of the motor lifting cable and it should have minimal angle.
- iv. Move the stop collars to lightly sandwich each cam-cylinder, leaving a slight gap between the stop collars and the cam-cylinders to avoid pinching. Tighten the set screws in the stop collars to lock them in place. NOTE: Pinching the cam-cylinders between the stop collars can create too much resistance with the cam-cylinder rotation and result in E-Lift motor stalls.

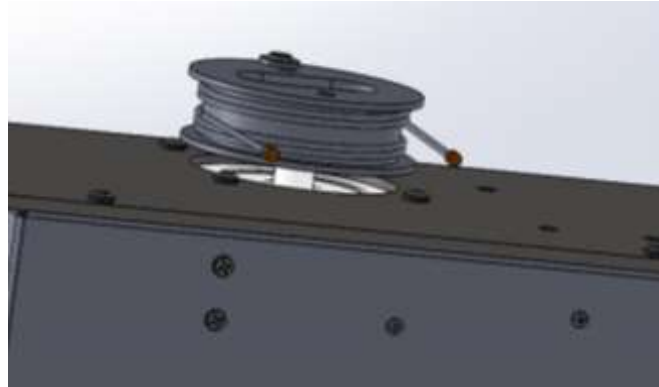

Fig. 2a – E-Lift Motor Double Pulley Cables (right side view)

Note: In this image the lower cable attaches to the lifting cylinder. The upper cable attaches to the lowering cylinder.

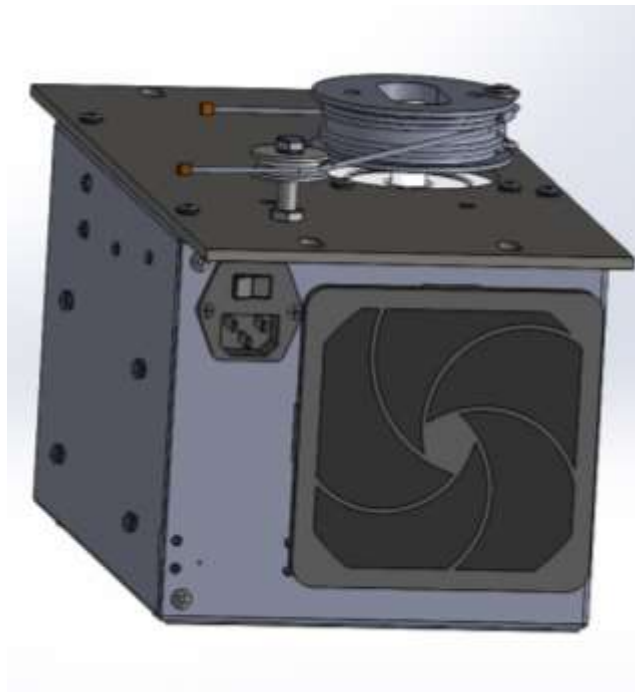

Fig. 2b – E-Lift Cable Routing (rear view)



Fig. 2c – E-Lift Cable Routing (front view)

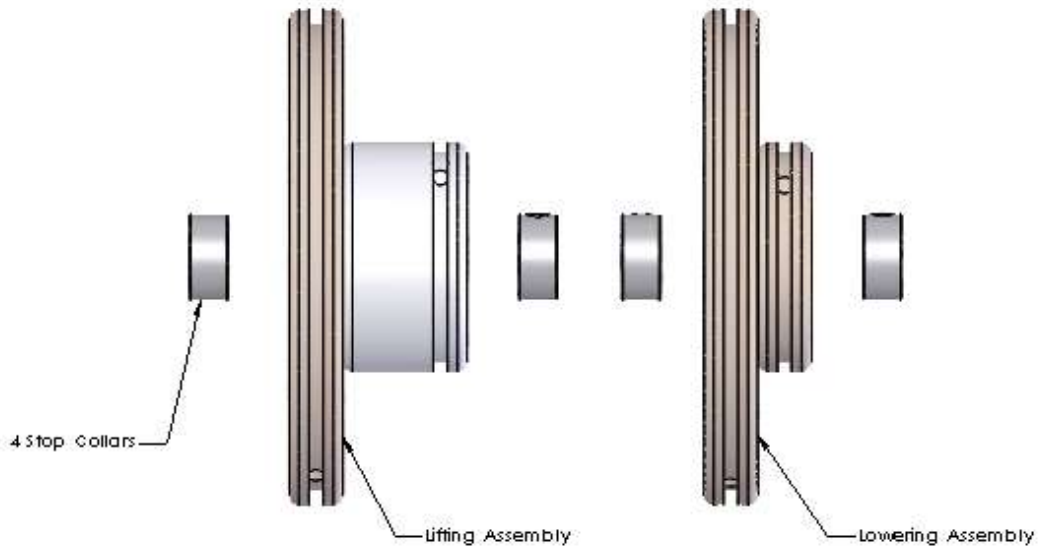

Fig. 3-A/N – Cam-cylinders Configuration for A-Series with Negative Dobby (right side view)

NOTE: Three possible configurations exist for the A-Series:

- negative dobbie-style head with the narrow “16H” back plate
- negative dobbie-style head with the wide “24/40H” back plate
- positive dobbie-style head with the wide “24H” back plate

All three configurations will have the same parts, however the cylinder on the lifting cam-cylinder will be of different lengths for each configuration.

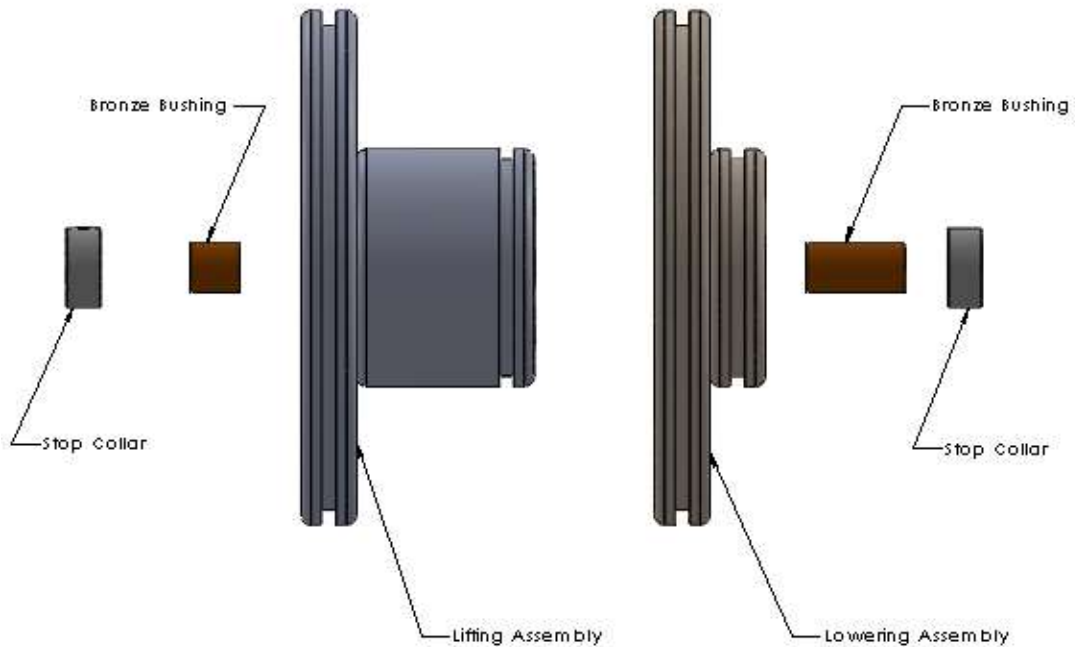

Fig. 3-P – Cam-cylinders Configuration for PDL (right side view)

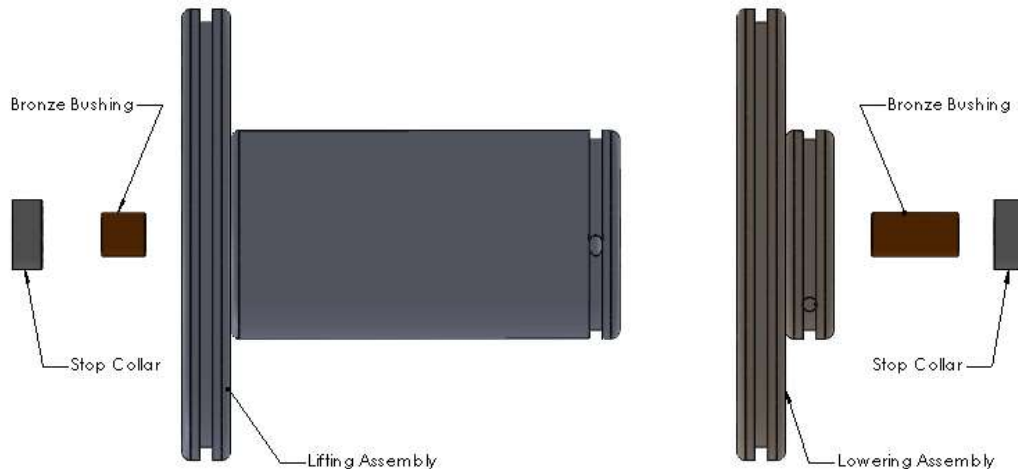

Fig. 3-T – Cam-cylinders Configuration for TDL (right side view)

- c. Attaching coated steel cables – There are 4 cables to attach. Do not unwrap the packaging securing the cables until instructed to do so. Start with the cables attached to the cam-cylinders.
- i. Unwrap the cable from the cylinder of the “lifting” cam-cylinder, extend it up and attach it to the slide plate or dobbie arm.
    1. If attaching to the slide plate the cable will end in a loop. The loop slides over the open eye bolt at the bottom of the slide plate. If the eye bolt is closed, then use the quick link to connect the cable to the eye bolt.
    2. If attaching to a post-1988 dobbie arm, the cable will end in a crimped ferrule. The ferrule end of the cable will be inserted in the bottom “R” (as marked in 1.a. above) hole in the dobbie arm. Pop the ferrule up and out of the top of the dobbie arm, attach the black plastic cable retainer button, and then pull the cable back down to seat it and the button in the dobbie arm.
    3. If attaching to a pre-1988 dobbie arm, the cable end will be stripped of sheathing. A loose ferrule will be supplied. Push the cable up through the “R” hole and then using a crimping tool, crimp the ferrule onto the stripped end of the cable. Note: Crimping the ferrule requires multiple squeezes to ensure the entire ferrule is fully compressed and smooth. This ensures optimal strength of the crimped joint. Please contact AVL for rental or purchase of a crimping tool if you do not already have one.
  - ii. Unwrap the cable from the cylinder of the “lowering” cam-cylinder, extend it up to and over the small pulley in the upper right corner of the dobbie head, then down to the slide plate or dobbie arm and attach it. Note: The small pulley on the slide plate equipped looms will have a cable retainer. The cable retainer is adjusted by loosening the center mounting bolt in the pulley. Loosen the retainer and slide it up to allow for installing the cable. Once the cable is installed, lower the retainer down and as close as possible but not touching the pulley, then tighten the center bolt to secure the retainer position.

1. If attaching to the slide plate the cable will end in a loop. The loop slides over the open eye bolt at the bottom of the slide plate. If the eye bolt is closed, then use the supplied quick link to connect the cable to the eye bolt.
2. If attaching to a post-1988 dobbie arm, the cable will end in a crimped ferrule. The ferrule end of the cable will be inserted in the bottom "R" (as marked in 1.a. above) hole in the dobbie arm. Pop the ferrule up and out of the top of the dobbie arm, attach the black plastic cable retainer button, and then pull the cable back down to seat it and the button in the dobbie arm.
3. If attaching to a pre-1988 dobbie arm, the cable end will be stripped of sheathing. A loose ferrule will be supplied. Push the cable up through the "R" hole and then using a crimping tool, crimp the ferrule onto the stripped end of the cable. Note: Crimping the ferrule requires multiple squeezes to ensure the entire ferrule is compressed and smooth. This ensures optimal strength of the crimped joint.

## SDL & V-Series Looms

Note: If you are replacing an existing E-Lift 2 or 2+ the mounting holes change location. Follow Figure 1a & Chart 1a for mounting hole drilling. Also, the return spring lever and spring should be removed from the rear treadle crossmember.

1. Preparing the loom:
  - a. Lightly mark in pencil each treadle pulley support cross member for correct positioning, with reference to front/back and up/down, before removing them from the loom. Also, lightly mark the dobbie arm in pencil with an "R" for which hole is used with the cable to the cam-cylinder, and with an "L" for which hole is used with the cable to the left treadle.
  - b. Disconnect the treadle cables at the treadles. Remove the treadles, treadle support mounting blocks and axles from the loom.
  - c. Disconnect both cables from the slide plate or dobbie arm. On older looms (pre-1988), dobbie arm cables are crimped in place and must be cut to remove them. On newer dobbie arm-equipped looms, black plastic cable retainer buttons are used in the dobbie arm to retain the cables. The buttons are removed from the opposite side as the cable entry hole by pushing the cable further into its entry hole. Retain the buttons for later use.
  - d. Remove the cam-cylinder and single pulley from the loom by removing the rear stop collar or axle cap, sliding the axle towards the front of the loom and partially out of the rear vertical side frame member until the cam-cylinder and single pulley are free to be removed. Remove them now along with the cables attached to the cam-cylinder.
  - e. Remove the treadle pulley support cross member assembly from the loom. Once off the loom, disassemble it by removing the treadle pulley axles and pulleys from the cross members.

2. Drilling the cross members: With the cross members located on a workbench or other suitable working surface, drill the holes required, as shown in Figure & Chart 1a.

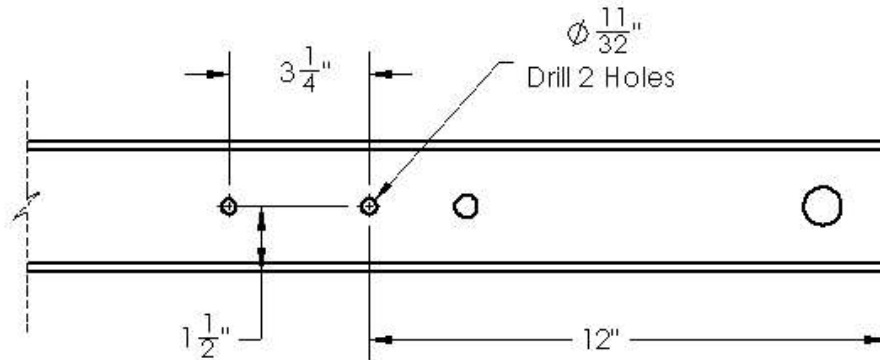

Figure 1a – SDL & V-Series Treadle Pulley Support Cross Members (Front and Rear) Holes

HOLE NO.	CROSS MEMBER	HOLE SIZE	HOLE ORIENTATION	DISTANCE FROM EDGE
1	front	11/32"	horizontal	12"
2	front	11/32"	horizontal	15 1/4"
3	rear	11/32"	horizontal	12"
4	rear	11/32"	horizontal	15 1/4"

Chart 1a – SDL & V-Series Cross Member Hole Information

3. Mount the E-Lift mounting blocks to the crossmembers with the supplied hardware.
4. Reinstall the cross members, remembering to align them as before.
  - a. Orient the E-Lift so that the power switch faces to the rear of the loom and the round switch receptacle faces the front of the loom.
  - b. Position the E-Lift under the treadle pulley support cross members to align the vertical holes in the E-Lift mounting plate with the pre-drilled vertical holes in the mounting blocks.
  - c. The Motor Box is heavy. It is recommended that two people lift the E-Lift into place while a 3rd person installs the mounting blocks and hardware. Or, use 2 pieces of 2"Tx4"Wx~6-12"L placed on edge under the bottom of the E-Lift housing to elevate it into position while getting the bolts and blocks in place.
5. Mounting the E-Lift:

- i. Insert the 5/16-18" x 6 1/2" hex bolt and flat washer into the pre-drilled vertical holes in the mounting blocks from the top down, letting them hang with the exposed ends pointing to the floor.
  - ii. Engage the bolts in the corresponding holes in the E-Lift mounting plate, and then loosely install a flat washer, lock washer and hex nut on each hex bolt.
  - iii. Repeat with the other set of bolts, adding the mounting block, E-Lift and remaining flat washers, lock washers and hex nuts.
  - iv. Tighten the mounting hardware.
6. Installing the cam-cylinders and coated steel cables:
- a. Installing cam-cylinders – E-Lift 3 comes with two cam-cylinders, one for lifting harnesses and one for lower harnesses.
    - i. Measure the diameter of your cam-cylinder axle. If it is 1/2" you will use 2 bushings inserted into each side of each new cam-cylinder in order to match the axle sizing. Otherwise, omit the 4 bushings in the package.
    - ii. Find the configuration for your loom in the following images. Slide the "lifting" cam-cylinder, "lowering" cam-cylinder, spacers and stop collars onto the axle as indicated in your loom's configuration.
    - iii. Slide the axle back into place in the rear vertical slide frame member and secure with a stop collar.
  - b. Aligning the cam-cylinders – The cylinder portion of each cam-cylinder is designed with a length to establish a direct route for its cables with as little angle as possible.
    - i. Before alignment, lubricating the cam-cylinder axle is recommended. Beeswax is a long-lasting lubricant that is rubbed directly onto the axle under where the cam-cylinders will operate. A dry, clear, spray Teflon or Silicone lubricant is also suitable, though it provides less longevity.
    - ii. Align the lifting cam cable path by line of sight with the left side of the E-Lift motor pulley. The cable should be straight on between the cam and motor pulley with minimal angle.
    - iii. Align the lowering cam cable path by line of sight with the right side of the small stand-off pulley mounted to the top of the E-Lift plate. This is the path of the motor lifting cable and it should have minimal angle.
    - iv. Move the stop collars to lightly sandwich each cam-cylinder, leaving a slight gap between the stop collars and the cam-cylinders to avoid pinching. Tighten the set screws in the stop collars to lock them in place. NOTE: Pinching the cam-cylinders between the stop collars can create too much resistance with the cam-cylinder rotation and result in E-Lift motor stalls.

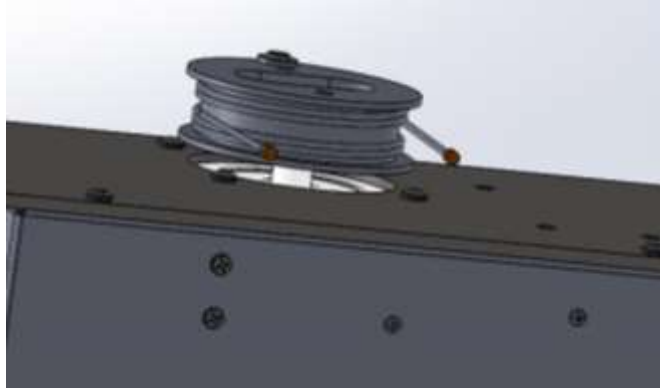

Fig. 2a – *E-Lift Motor Double Pulley Cables (right side view)*

Note: In this image the lower cable attaches to the lifting cylinder. The upper cable attaches to the lowering cylinder.



Fig. 2b – *E-Lift Cable Routing (rear view)*  
(front view)



Fig. 2c – *E-Lift Cable Routing*



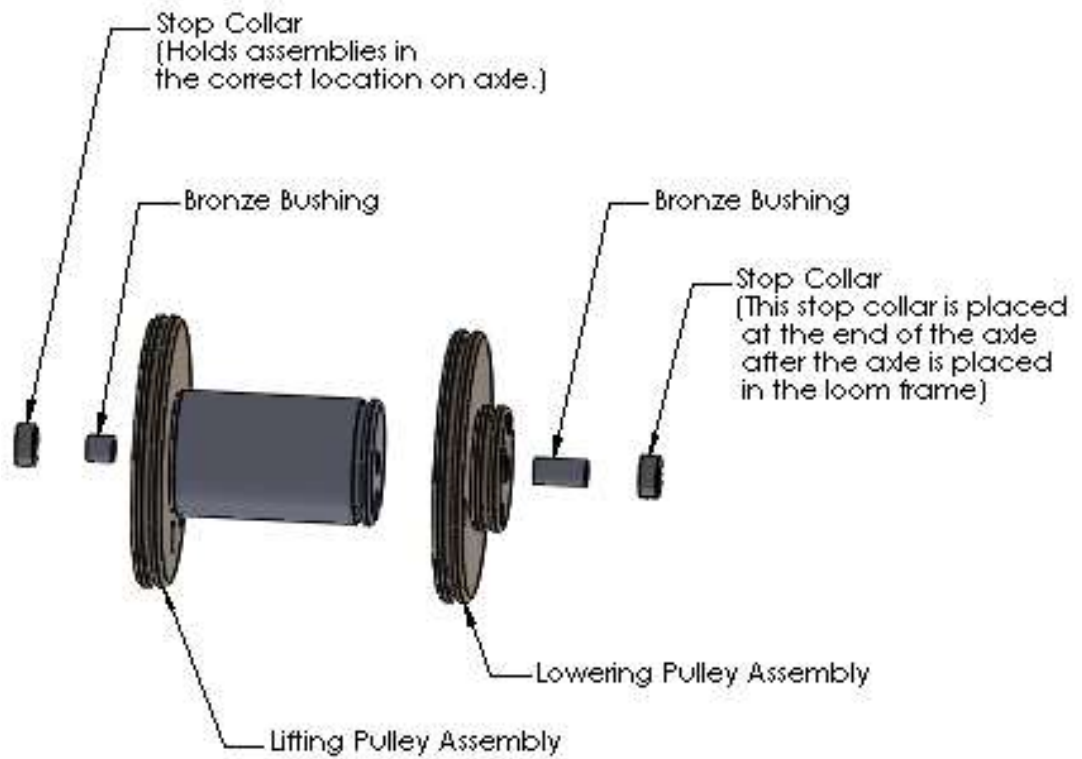

Fig. 3-S – Cam-cylinders Configuration for SDL (right side view)

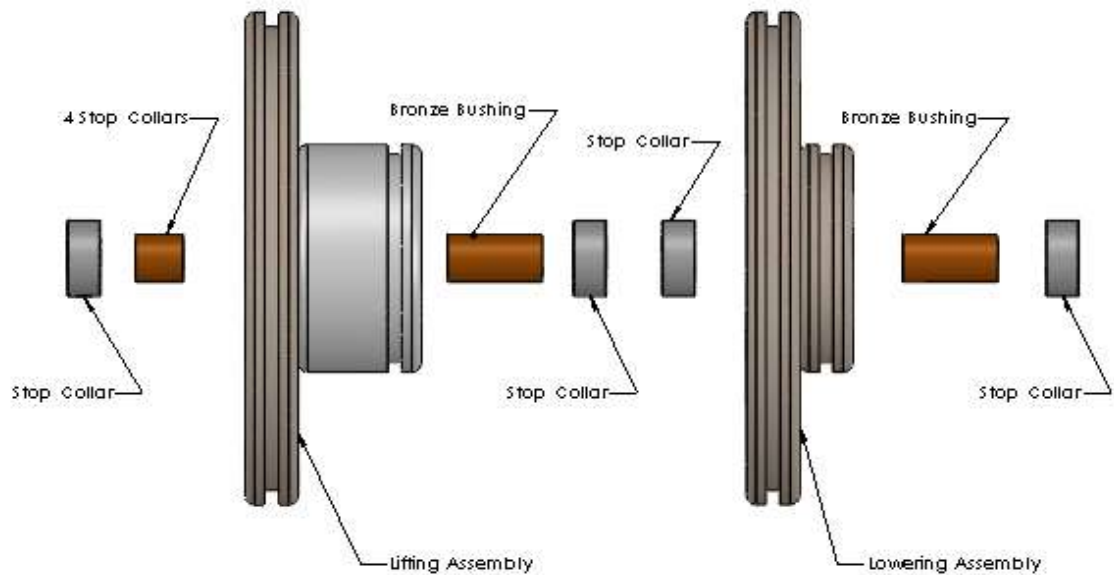

Fig. 3-V – Cam-cylinders Configuration for V-Series (right side view)

- c. Attaching coated steel cables – There are 4 cables to attach. Do not unwrap the packaging securing the cables until instructed to do so herein. Start with the cables attached to the cam-cylinders.
- i. Unwrap the cable from the cylinder of the “lifting” cam-cylinder, extend it up and attach it to the slide plate or dobbie arm.
    1. If attaching to the slide plate the cable will end in a loop. The loop slides over the open eye bolt at the bottom of the slide plate. If the eye bolt is closed, then use the supplied quick link to connect the cable to the eye bolt.
    2. If attaching to a post-1988 dobbie arm, the cable will end in a crimped ferrule. The ferrule end of the cable will be inserted in the bottom “R” (as marked in 1.a. above) hole in the dobbie arm. Pop the ferrule up and out of the top of the dobbie arm, attach the black plastic cable retainer button, and then pull the cable back down to seat it and the button in the dobbie arm.
    3. If attaching to a pre-1988 dobbie arm, the cable end will be stripped of sheathing. A loose ferrule will be supplied. Push the cable up through the “R” hole and then using a crimping tool, crimp the ferrule onto the stripped end of the cable. Note: Crimping the ferrule requires multiple squeezes to ensure the entire ferrule is compressed and smooth. This ensures optimal strength of the crimped joint.
  - ii. Unwrap the cable from the cylinder of the “lowering” cam-cylinder, extend it up to and over the small pulley in the upper right corner of the dobbie head, then down to the slide plate or dobbie arm and attach it. Note: The small pulley on the slide plate equipped looms will have a cable retainer. The cable retainer is adjusted by loosening the center mounting bolt in the pulley. Loosen the retainer and slide it up to allow for installing the cable. Once the cable is installed, lower the retainer down and as close as possible but not touching the pulley, then tighten the center bolt to secure the retainer position.
    1. If attaching to the slide plate the cable will end in a loop. The loop slides over the open eye bolt at the bottom of the slide plate. If the eye bolt is closed, then use the supplied quick link to connect the cable to the eye bolt.
    2. If attaching to a post-1988 dobbie arm, the cable will end in a crimped ferrule. The ferrule end of the cable will be inserted in the bottom “R” (as marked in 1.a. above) hole in the dobbie arm. Pop the ferrule up and out of the top of the dobbie arm, attach the black plastic cable retainer button, and then pull the cable back down to seat it and the button in the dobbie arm.
    3. If attaching to a pre-1988 dobbie arm, the cable end will be stripped of sheathing. A loose ferrule will be supplied. Push the cable up through the “R” hole and then using a crimping tool, crimp the ferrule onto the stripped end of the cable. Note: Crimping the ferrule requires multiple squeezes to ensure the entire ferrule is compressed and smooth. This ensures optimal strength of the crimped joint.

## OPERATING THE E-LIFT

1. If not already done:

- Connect the foot or hand switch cord to the E-Lift, ensure the plug is fully seated.
- Connect the power cord to the E-Lift, then plug into a power supply/wall outlet.

Refer to Figures 2b & 2c for locations of plug receptacles.

Turn on the E-Lift using the power switch, located next to the power cord. Refer to Figure 2b for power switch location.

2. Setting the Home position: The “Home” position is the starting point for normal E-Lift weaving operation. Once set correctly, this will place the loom’s slide plate or dobbie arm in the UP position resting on the rubber bumper located on the right slide rod or right side dobbie arm slot. When the slide plate or dobbie arm are in the up position, the harnesses are down in the “Shed Closed” position. And when the slide plate or dobbie arm is down the harnesses are raised in the “Shed Open” position. The rest of this document will refer to these two states as Shed Closed or Shed Open. The following procedure is required each time the E-Lift is powered on. When the E-Lift is first powered on, it starts in ‘Homing’ mode. Homing mode allows you to use the E-Lift to move the dobbie to Shed Closed.

- a. If the dobbie is already at Shed Closed, it is in the correct Home position. To set Home position, press and quickly release the switch. The next press of the switch will be for normal weaving operation.
- b. If the dobbie is not in the Shed Closed position:
  - i. Press & hold the switch.
  - ii. After a brief pause, the E-Lift will slowly move the slide plate or dobbie arm up towards the Shed Closed position. Be ready to release the switch.
  - iii. When the Shed Closed position is reached, the slide plate or dobbie arm will stop moving. Immediately release the switch to set the home position. The next press of the switch will be for normal weaving operation.

Please note:

- If during Homing the switch is released too early, i.e. before reaching Shed Closed, the E-Lift must be powered off for 30 seconds, powered back on and the Homing procedure repeated.
- If during Homing the switch is held for a prolonged amount of time while the slide plate or dobbie are stopped, the motor will stall and the switch may become unresponsive. To reset a stalled motor, power off the E-Lift, waiting 30 seconds, power it back on, and then repeat the Homing procedure.

3. Normal Operation: The loom has two standard Modes of use, Double-shed and Single-shed. While it is acceptable to use either Mode for weaving, Double-shed is the more efficient approach.
  - a. Double-shed Mode:
    - i. After setting the Home position, the E-Lift starts in Double-shed Mode, by default.
    - ii. After Homing, the slide plate or dobbie arm should be up. Selecting the switch will move the slide plate or dobbie arm down and stop.
    - iii. Each selection thereafter will cause the E-Lift to move the slide plate or dobbie arm up to allow for the selection of a pattern shed, and then immediately down again to open the shed (assuming harnesses are selected in the dobbie).
  - b. Single-shed Mode:
    - i. After switching the Mode to Single-shed, the next switch selection will move the slide plate or dobbie arm in one direction, either up or down and stop.
    - ii. Each subsequent switch selection will move the slide plate or dobbie arm in the opposite direction and stop.
    - iii. Then, the following switch selection will move the slide plate or dobbie arm down, etc.

Please note: It is acceptable to use either Double-shed or Single-shed mode. However, Double-shed mode is more efficient. Single-shed mode is intended where loom diagnostics are being performed or slower weaving is needed.

4. Changing Modes:
  - i. Changing Modes is available only after Homing is completed.
  - ii. Changing between Modes is accomplished by pressing and holding the switch for a full 10 seconds. If the switch is not pressed for a full 10 seconds, the normal operation will be performed.
  - iii. Immediately after releasing the switch, wait for approximately 3 seconds before attempting to engage the switch.
  - iv. The next switch selection will be in the new Mode. There are two Modes of operation for the E-Lift, Double-shed and Single-shed. Double-shed is the most efficient mode for weaving.

## MAINTENANCE AND REPLACEMENTS

### Required Maintenance

- Clean the air filter elements *weekly or as use and dust & lint conditions dictate*.
  - The filter elements are secured to the front and rear E-Lift housing by square plastic rings that snap on/off.
  - Vacuuming of the filter elements while still in place on the E-Lift is an acceptable means of cleaning.
  - For deep cleaning, the square plastic rings may be removed, and then the filter elements may be washed in warm, soapy water. Be sure the element is completely dry before you replace it.
- Inspect the cables for wear *monthly*, especially where they move over pulleys.
- Check the mounting hardware and re-tighten if loose *seasonally*.
- Inspect the cables for slack and the spring for over-stretch *yearly*.
  - If any of the cables are hanging loose, the cables have become stretched or the spring is over-stretched.
  - Remove the spring to determine if it is the cause. Without tension, the spring coils should completely close. If you see space between the coils replace the spring and recheck the cables for slack.
  - If the cables are showing slack with a good spring in place, the cables must be replaced.
- Lubricate the cam-cylinder axle yearly. Beeswax is a suitable, long-lasting lubricant to rub onto the axle under where the cam-cylinders rotate. Dry, clear, spray Teflon or Silicone lubricants are also suitable, but with shorter working life.

Your E-Lift is designed to provide years of dependable service. When replacement parts, such as the air filter or cables are needed, AVL is your source. AVL may also be able to rebuild your E-Lift when it reaches the end of its wear cycle. Please contact us at 530-893-4915 or [sales@avlusa.com](mailto:sales@avlusa.com) to discuss with your AVL representative.