



AVL Looms  
2360 Park Avenue  
Chico, CA 95928-6785  
U.S.A.

530 893-4915  
530 893-1372 fax  
sales@avlusa.com  
www.avlusa.com

## Drill the holes for the casters

There are four casters, which should be placed at each corner of the loom. The holes that need to be drilled are size H or 0.266 inch diameter. Two thru holes will need to be drilled for each bracket.

### Note:

The casters are attached to the side of the loom. On the rear legs, the holes are drilled through the narrow side of the leg. Please read all of this handout and review the pictures on pages 3 & 4 before drilling the holes.

- 1) Use the front casters diagram to determine where the holes should be drilled on the front legs. Mark the position of the hole on the loom.

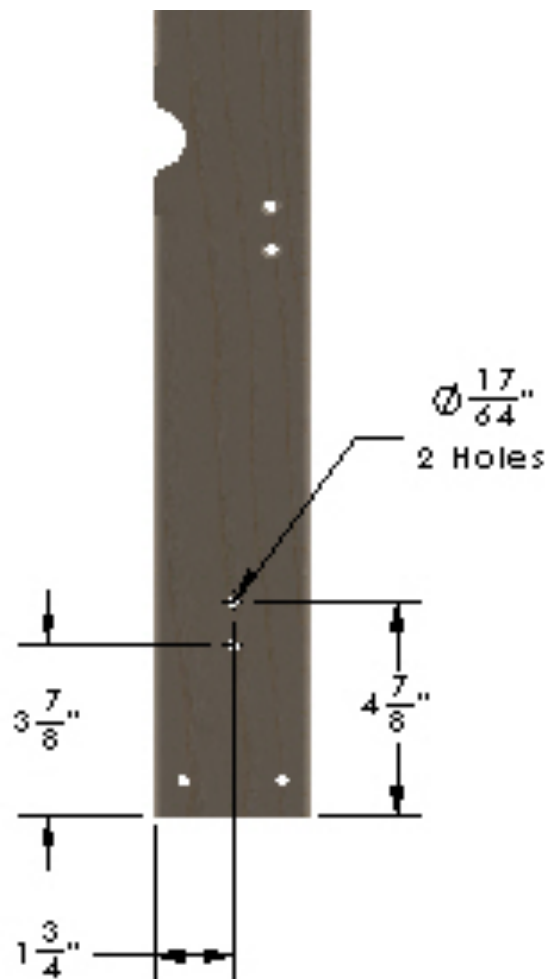
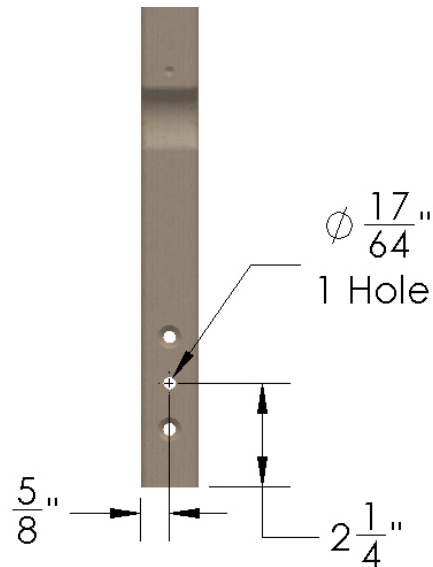

Figure 1 - Drill diagram for front legs



- 2) Use the rear casters diagram to determine where the holes should be drilled on the rear legs. Mark the position of the hole on the loom.



**Figure 2 - Drill diagram for rear legs**

- 3) Drill thru the frame at the marked holes using a size H (.266") diameter bit.

### Attach Casters

One of the available options for the K-series loom is wheeled casters which allow the loom to be easily moved from one location to another. When the loom is not being moved, the casters are securely locked into position.

#### Note:

**The casters at the front of the loom are positioned at the sides. The casters at the rear of the loom face the back.**

- 1) Find the four casters and the hardware. There are four long bolts and four short ones. The short bolts are used on the front of the loom and the long bolts are used at the rear.
- 2) Place a caster on the front leg of the loom against the drilled holes on the side frames, with the bracket facing up. Place the short bolts through the holes in the caster and the loom from the inside of the loom.
- 3) Secure each bolt with a nut.
- 4) Repeat for the other front leg.



**Figure 3 - Caster attached to front leg of the loom**

- 5) Place a caster at a rear leg of the loom against the drilled holes, with the bracket facing down. Use the long bolts to secure the casters to the loom.
- 6) Secure each bolt with a nut.
- 7) Repeat for the other rear leg



**Figure 4 - Caster attached to rear leg of loom**