

AVL Air Shuttle System Assembly and Operating Instructions



**AVL Looms
2360 Park Avenue
Chico, CA 95928-6785
U.S.A.**

530 893-4915

530 893-1372 (fax#)

[info@avlusa.com\(e-mail\)](mailto:info@avlusa.com)

www.avlusa.com

v. 1.0

Updated December 20, 2019

Copyright ©2019

All Rights Reserved Worldwide



Air Shuttle Installation3
 Air Component Information5
 Air Compressor Requirements.....5
 Tools7
 Parts7
 Convert Bottom Swing Beater8
 Remove existing Drop Box20
 Add the drop box assembly to the beater21
 Mount the Air System25
 Attach the Air Shuttle switch.....26
 Mount the Left and Right Piloted Valves27
 Installing the FRL and Manifold.....29
 Mount the Safety Valve31
 Air Dobby or Air Lift Interface34
 Connecting the components to compressed air34
 Air Shuttle Operation36
 Binder Clip Tensioning37
 Calibrating38
 Maintaining Your System.....39
The Fine Print41
 AVL Customer Service42
 AVL Warranties42



AIR SHUTTLE INSTALLATION

These instructions will guide you through the installation of your Air Shuttle System and will teach you how to operate it safely and effectively. You'll find that the AVL Air Shuttle is easy to install and use, with little upkeep.

AIR COMPONENT INFORMATION

Compressor

A machine which compresses, stores, and delivers air to an air system.

Air Cylinder

A sealed tube that contains a movable shaft. This shaft is caused to move in or out by the action of compressed air.

Exhaust Valve:

The work in your Air Shuttle is done by compressed air. This air comes into the system via the compressor, is forced through the cylinder, and is then vented from the system. An exhaust valve is the door through which the air leaves.

FRL:

This is a filter and regulator together in a single device. The air that comes from your compressor feeds directly into the FRL where it's conditioned and its pressure regulated.

Piloted Valve:

This valve directs the flow of air to and from different parts of the system.

Rod End:

The working end of an air cylinder. It connects to the mechanism that needs to be moved.

AIR COMPRESSOR REQUIREMENTS

Compressors are rated according to the volume of compressed air they can delivery in one minute. This rating is known as C.F.M., cubic feet per minute.

DEVICE	USAGE	UNITS	PER	COMPRESSOR RATING *	UNITS	NOTES
Air-Assisted Shuttle Boxes	0.47	CFM @ 100 PSI	Loom	2	CFM	Rated @ 60 PPM

PPM = Picks Per Minute

CFM = Cubic Feet Per Minute

PSI = Pounds Per Square Inch

We suggest sizing a compressor for worst case scenarios like 50% duty cycle. When using a 50% duty cycle, doubling the usage rate is the first step, then adding another 50% will insure the compressor is not working at maximum capacity, making it last longer and delivering reliable compressed air to AVL products.

Note:

If you will be using multiple air components, make sure your air compressor is sized to handle all of them.

Exceptions to the above sizing methods are products that may use compressors other than the reciprocating type. Screw type compressors are often used in higher volume applications such as IDL's, or a Jacquard with several heads.

The choice of a compressor is yours. In general, we advise you to buy a compressor that can deliver more air than you actually need -- it will run more efficiently, last longer, and allow the addition of future air components.

Nearly all compressors have storage tanks. Here, too, size is important. We recommend that you consider a compressor with at least a twenty gallon tank.

TOOLS

The tools needed vary depending on the specific loom you are installing the Air Shuttle on. Below is a list of the possible tools you might need.

- Slot Screwdriver
- Medium Phillips screwdriver
- ½" Socket wrench and ratchet
- Crescent wrench
- 9/16" combination wrench
- 7/16" combination wrench
- 1/8" Allen wrench
- 5/32" Allen wrench
- Electric drill
- 9/64" drill bit
- Tape measure
- Ruler or straight edge
- Pencil

PARTS

Check to be sure you have received all of the following parts.

Received	Quantity	Item
	1	Hardware Pack
	1	FRL Unit (If the loom does not already have one)
	1	Switch assembly or foot pedal
	1	Safety switch assembly
	2	Piloted valves
	1	Tubing bundle connected to components
	1	Left box assembly with cylinder
	1	Right box assembly with cylinder
	1	Air doobby interface (If the loom has an air doobby)

CONVERT BOTTOM SWING BEATER

The Air shuttle is designed to work with an overhead beater. If your loom currently has a bottom swing beater, you will need to install the overhead beater before installing the air components. If you already have an overhead beater, skip to page 20.

Overhead Beater Axle Mounting Blocks

- 1) Find the package marked "axle blocks". These blocks have a large hole in them.
- 2) Using the 5/16" x 5" carriage bolts in the package, mount these blocks to the back edge of each rear side support.



Figure 1 - Axle Block on loom

Mount the Beater Retainer

The beater retainer will be attached to the inside face of the left cloth beam support.

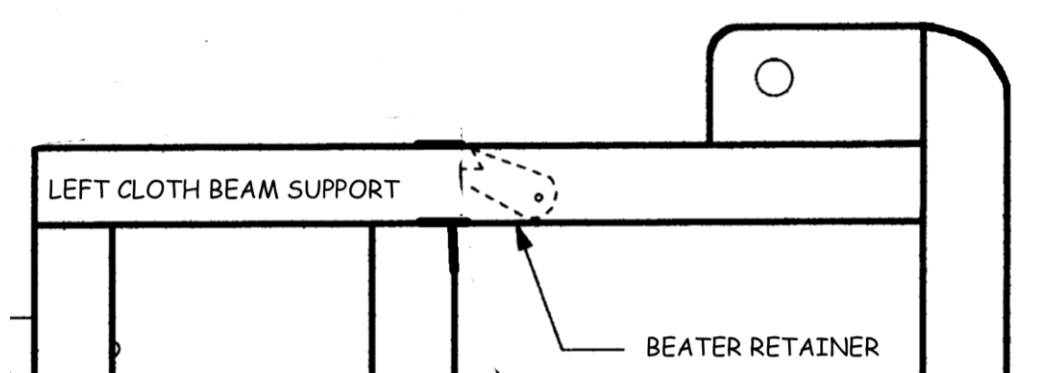

Figure 2 - Beater Retainer

- 1) Insert the #12 x 1-1/2" flat head wood screw through the beater retainer and into the pre-drilled hole on the inside of the left cloth beam support.



Figure 3 - Beater Retainer

- 2) Leave the screw just loose enough so that the retainer is allowed to pivot around the screw.

Attach the Beater Pivot (Adjustment) Base

Note:

You may need a small ladder or stepstool to install the Beater Pivot Base.

- 1) Place the beater pivot bases on the upper edge of each top horizontal on the assembled side frames of your loom so the notched ends face upward.

- 2) Insert the #8 x 3/4" pan head wood screws from the top of the beater pivot bases and screw them into the pre-drilled holes.

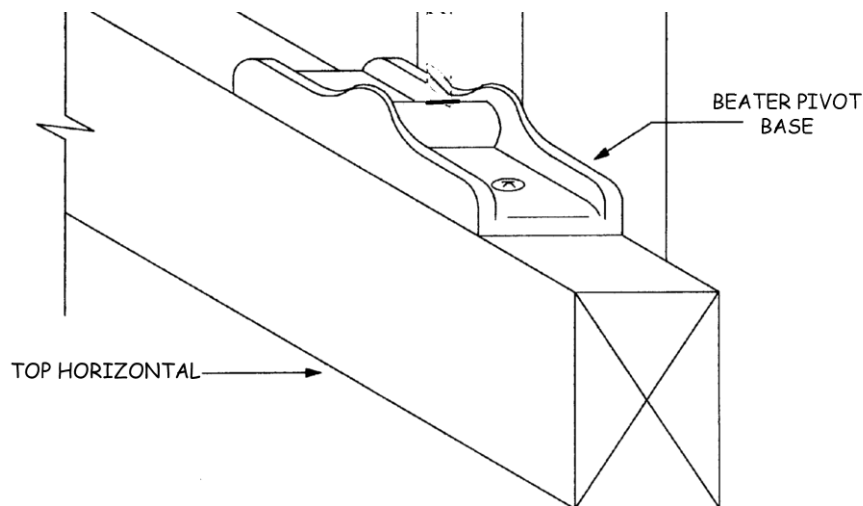

Figure 4 - Beater Pivot Base

Replace the beater bumper blocks

- 1) Remove the existing bumper blocks.
- 2) Replace them with the new ones included with the new overhead beater.

Assemble the Beater

- 1) Find the two uprights and lay them on the floor spaced apart a distance that is approximately equal to the width of your loom. The ends with the metal brackets will be the top of this assembly. The metal rods should be pointed inward or toward each other.

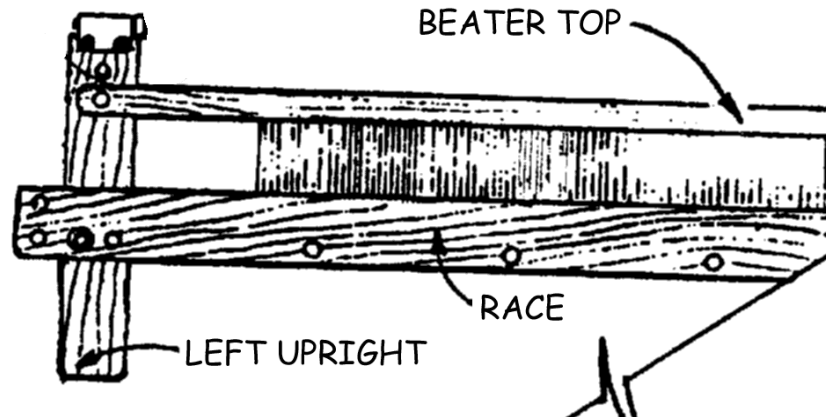

Figure 5 - Overhead Beater

- 2) Lay the shuttle race on top of the two uprights so that it covers the two holes in the face of each upright. The groove in the shuttle race will be to the top and back when the beater is on the loom. For now it should face the floor.

Note:

If you have the single-box flyshuttle, the two rear plywood box sides should fit into the notches on the front face of each upright. If you have a two-box or four-box flyshuttle, there is a metal pulley attached to the back face of each upright. These pulleys should now be touching the floor.

- 3) Attach the shuttle race to the uprights with a 5/16" x 3-1/2" carriage bolts on each side using the innermost hole on each end.
- 4) Place the washers and hex nuts on these carriage bolts, but do not tighten them yet.
- 5) The beater top will be attached to the same side of the uprights as the shuttle race with the long groove facing downward. Temporarily attach the beater top to the uprights with two 1/4" x 2-1/4" carriage bolts with washers and wing nuts behind the uprights.

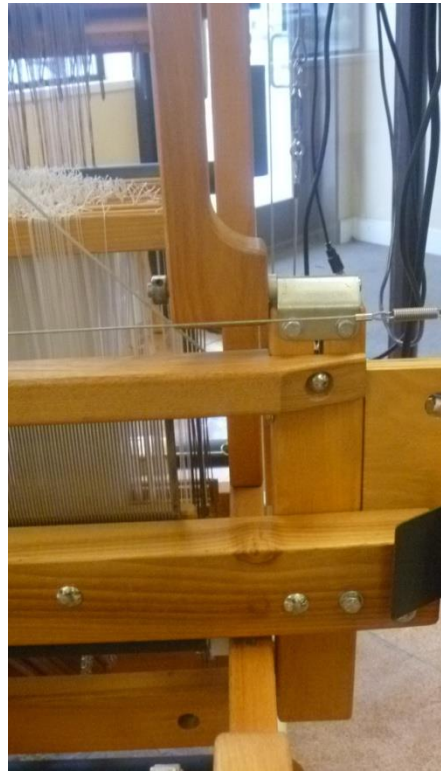

Figure 6 - Overhead Beater Uprights

- 6) Insert the carriage bolts through the holes near each end of the beater top and then through the slots that are just below the metal bracket of each upright.
- 7) Place the beater in the loom. For now, it will just sit in the loom resting on top of the cloth beam supports just in front of the harnesses. It may tend to fall forward or backward until it is attached later in this process.

Mount the Hanging Arms

The hanging arms are marked right and left. Make sure you install the correct arm for each side.

- 1) Using a 1/8" Allen wrench, remove the 3/8" stop collars from the metal shafts at the top of the upright on the beater.

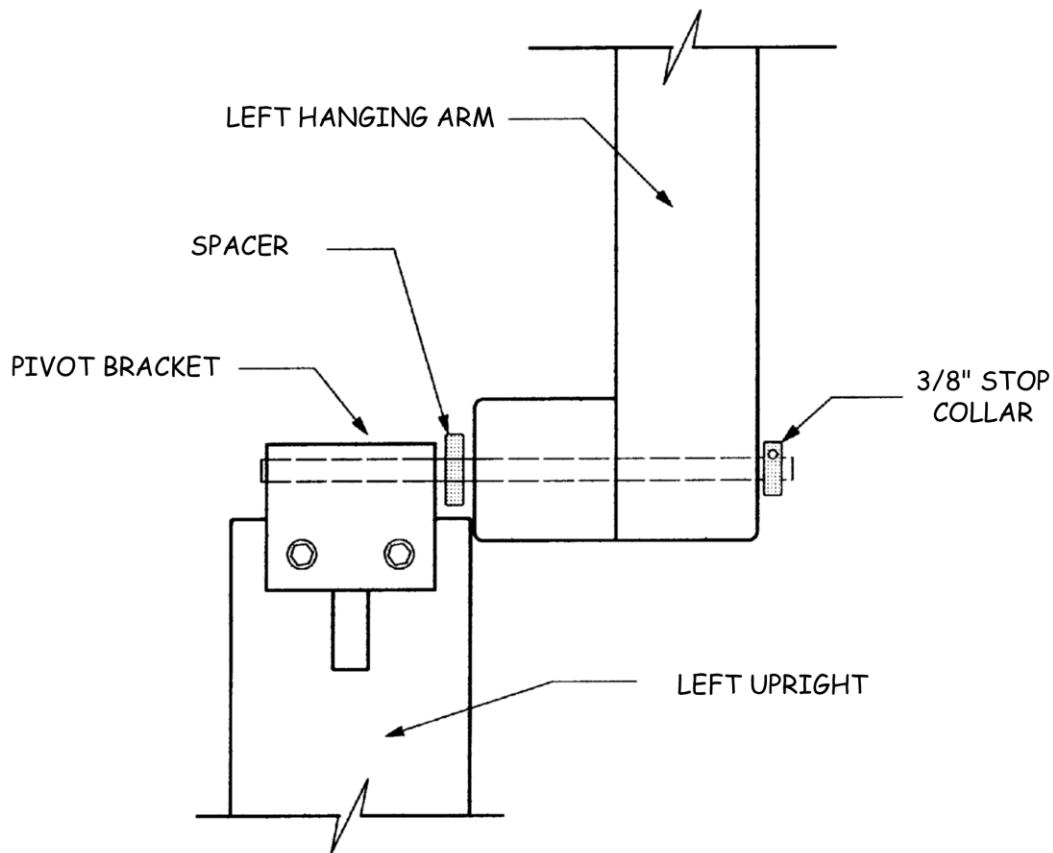

Figure 7 - Mount hanging arms

- 2) Put a spacer, than a hanging arm onto the shaft
- 3) Replace and tighten the stop collar. Make sure to leave enough clearance for this pivot point to swing freely.
- 4) Install the other arm in the same way.
- 5) On the other end of the hanging arm there is a block of wood that the beater adjustment screw goes through.
- 6) Set the foot at the bottom of the beater adjustment screw into the notch in the center of the beater pivot base.

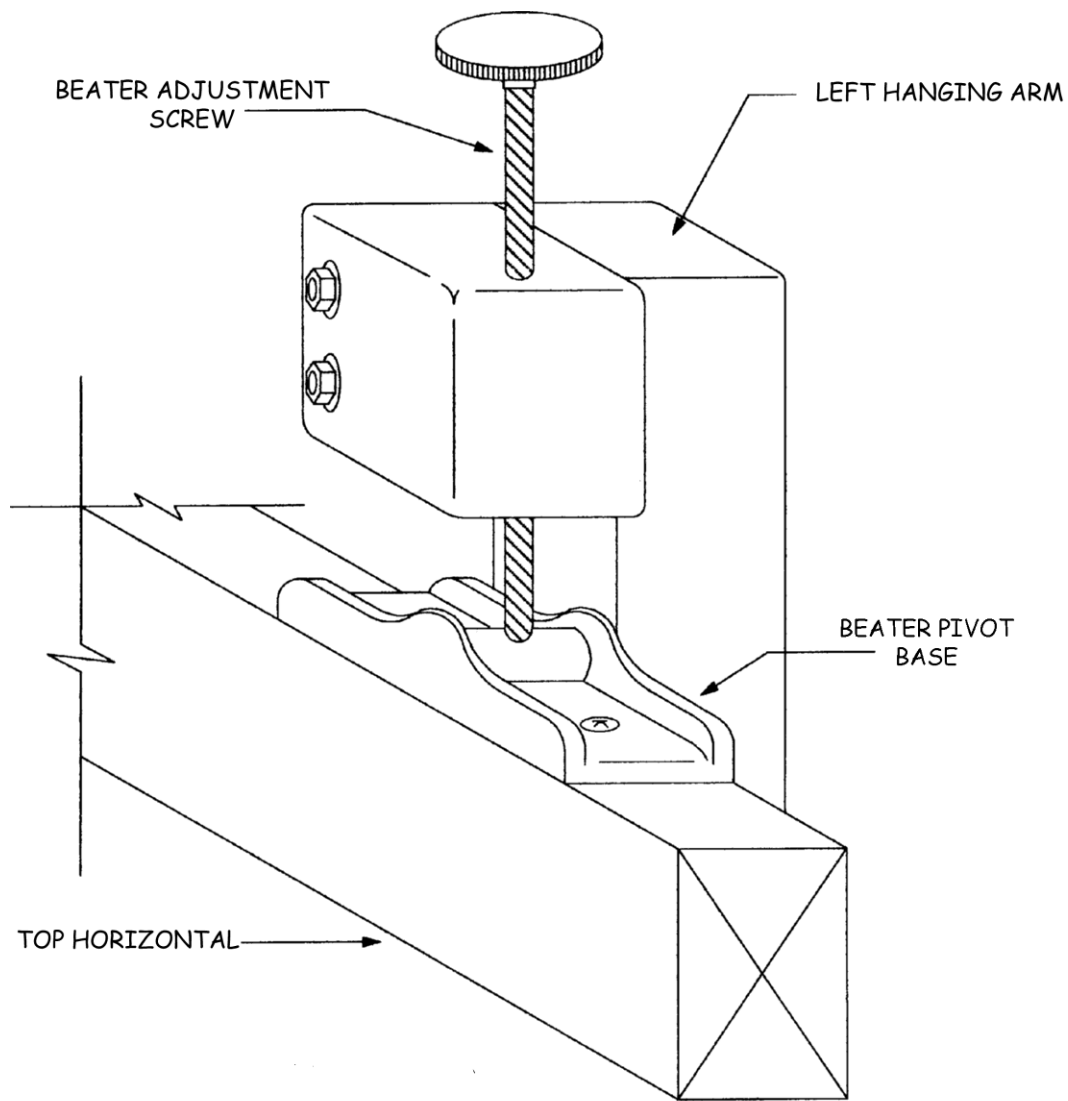

Figure 8 - Place Hanging Arms on Loom

- 7) Once you have both of the beater adjustment screws in place, the assembly of the hanging arms is complete.

Note:

You can use the beater adjustment screws to adjust the height of the beater. Make sure to adjust them equally so that the beater is level.

Insert the axle and the tilting arms

The axle is a long, black pipe that goes through the axle mounting blocks at the bottom of the loom. It will hold the tilting arms for the overhead beater, which are marked right and left. The tilting arms have a beater return spring

assembly consisting of a spring, cord, and eyebolt. This is attached later in the process.

- 1) Center the axle in the loom and place an axle spacer (a round, plastic piece) on each end of the axle.
- 2) The hole at the larger end of the tilting arm will be pushed onto the axle.



Figure 9 - Beater Axle

- 3) Attach the tilting arm with 5/16" x 3" hex bolts using the washers and hex nuts provided.

Note:

These are called “racking adjustment bolts”. Do not tighten these bolts yet.

- 4) Repeat these steps for the other side.

Add the push arms

- 1) Mount the push arm to the back face of the upright.

- 2) Insert two 5/16" x 5" hex bolts, washers, and square nuts through the shuttle race and uprights into the nut access hole of the push arm.



Figure 10 - Push Arms and Tilt Arms

- 3) Tighten these bolts making sure that the outer face of each push arm is flush with the outer edge of the uprights.
- 4) Repeat for the other side of the loom.

Tighten bolts

- 1) At this point you can tighten the bolts on the beater, except for the racking adjustment bolts. Make sure the beater is relatively square and centered in the loom.

Rack the Beater

You will rack the beater to make sure it is square to the loom so that it beats your fabric properly. You can tell if the beater is square to the loom by seeing if the beater hits one bumper before it hits the other. If the beater should come "out of square" in the future, you will need to repeat this adjustment, loosening the bolts before you start and tightening them securely after.

Note:

You will need two people to complete this operation.

- 1) The racking adjustment bolts should be tightened while the entire beater is being held firmly against the beater bumpers.

Note:

When racking the beater, the beater must touch both the left and the right bumpers at the same time.

- 2) Push on the upper end of each tilting arm and while the beater is in contact with both of the bumpers, securely tighten the "racking adjustment bolts".

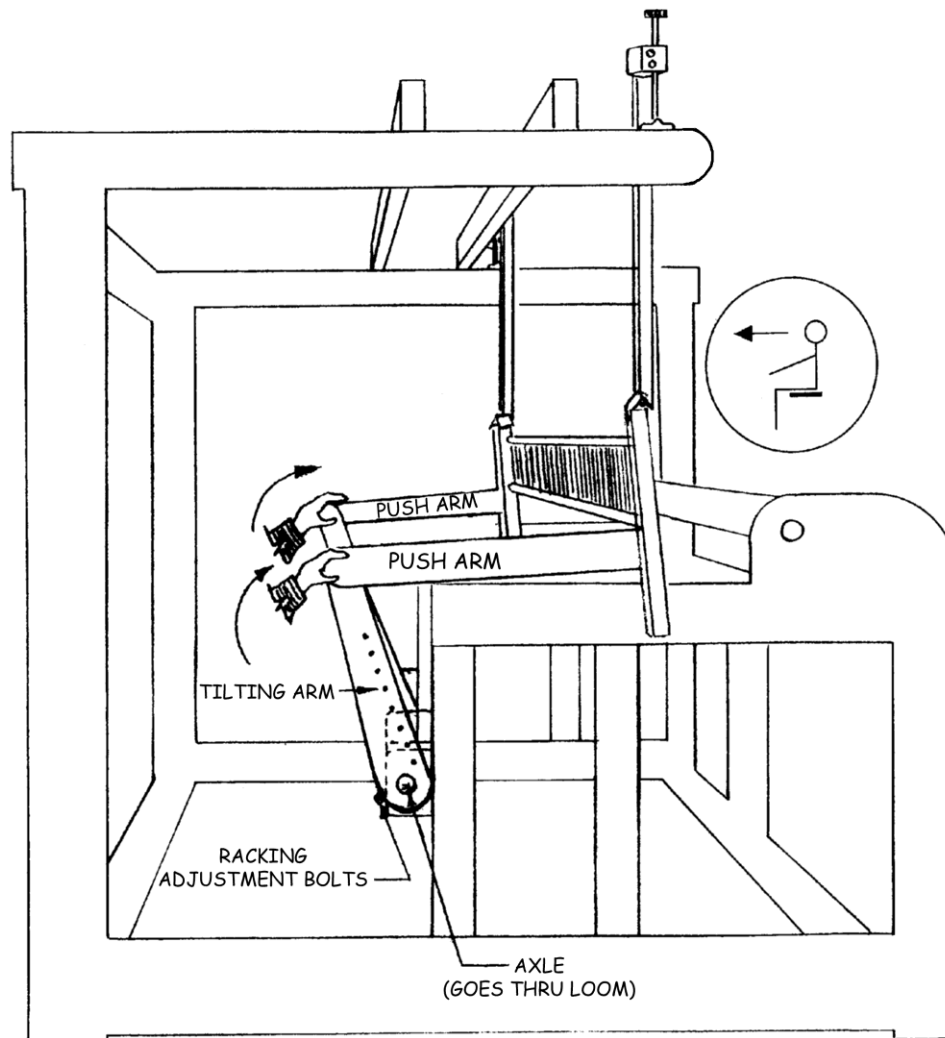

Figure 11 - Racking the Overhead Beater

Attach the Beater Return spring assembly

This assembly is used to assist the weaver in returning the beater to the back position. It is not intended to hold the beater in this position as that is the purpose of the beater retainer.

The beater return spring assembly is adjustable. It is tightened by pulling on the ends of the white cord while squeezing the black, minicord lock on the assembly. Whenever an adjustment is made on one side of the beater, a similar adjustment should be made on the other side as well. The amount of tension you set these springs at is strictly a matter of preference.

Generally speaking, the stronger the tension, the harder you will have to pull against these springs to beat. At the same time, however, it will be easier to hold the beater away from you while opening a shed and throwing the shuttle.

You may wish to experiment with these adjustments in order to come up with a setting that works best for you and any particular warp.

Note:

If you will be installing a two-box or four-box flyshuttle, you may want to add the boxes before attaching the Beater return spring assembly.

- 1) Remove one hex nut and washer from the eyebolt.

- 2) Place the eyebolt through the hole provided on each bottom horizontal of the side frame assembly with the eye of the bolt on the outside of the side frame.



Figure 12 - Beater Return Spring Assembly

- 3) Replace the washer and hex nut and tighten securely.

Add the reed to the beater

Note:

Do not add the reed to the beater until you have attached the air system.

- 1) Find the reed support. It is the long, thin, wooden part with several holes and a slot similar to the one in the shuttle race.
- 2) Attach the reed support to the back of the shuttle race with the slot to the top and facing the shuttle race using the 5/16" x 3-1/4"

carriage bolts inserted from the front with washers and wing nuts behind.



Figure 13 - Beater Reed Support

- 3) Before attaching the nuts, install the bottom edge of your reed in the void created by the slots in the reed support and shuttle race.
- 4) Center the reed between the two uprights and tighten the wing nuts.
- 5) There is a slot in the underneath side of the beater top which slides over the top edge of the reed.
- 6) Push the beater top down on the reed and tighten the wing nuts which hold it in place.

REMOVE EXISTING DROP BOX

If your loom already has an overhead beater, you will need to remove some components in order to attach the new air system.

- 1) Disconnect and remove your flyshuttle tie-up handle and cords.
- 2) Disconnect the metal shift handle cables at the spring ends (where they attach to the turnbuckles).
- 3) Remove the beater top and reed and set them aside.
- 4) Use a socket wrench with a 1/2" socket to remove the two bolts which hold the left back plate to the end of the beater race.

Note:

Unless otherwise noted, any hardware that is removed will be replaced as you reassemble the system. Put it in a safe place until you are ready for it.

- 5) Remove the bolt that secures the back plate assembly to the upright. Remove the back plate assembly and set it aside.
- 6) Remove the right back plate assembly in the same fashion.

ADD THE DROP BOX ASSEMBLY TO THE BEATER

The Drop box assembly is marked left or right.

- 1) Find the left drop box assembly. There are two holes through the back plate in the lower right corner and a nut access hole in the upper right corner.

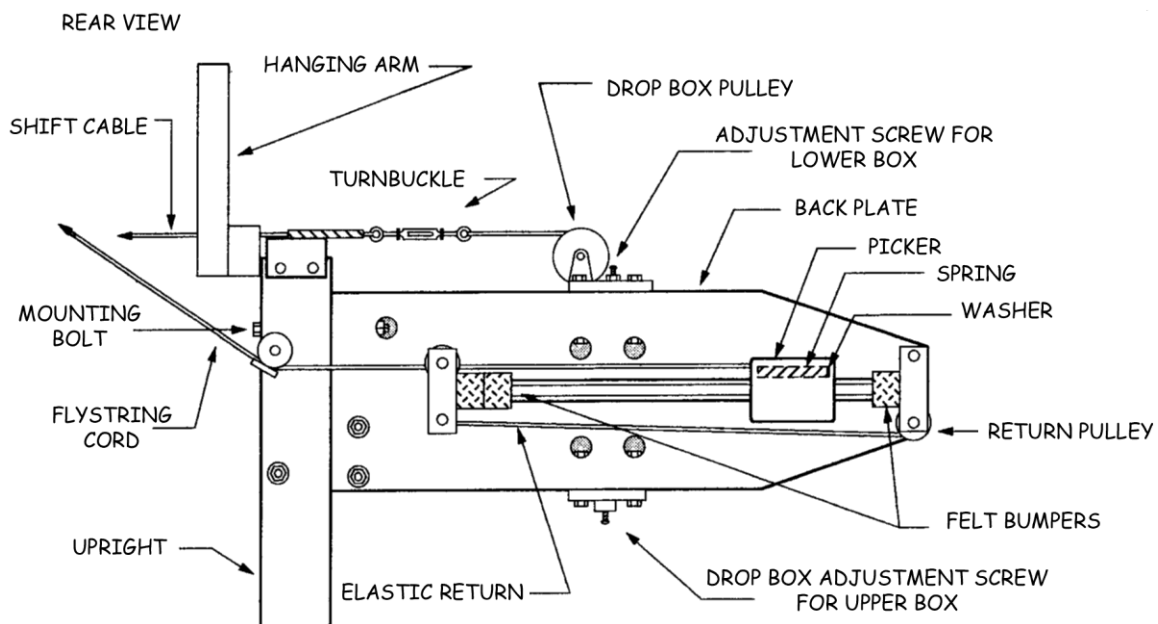

Figure 14 - Drop Box Assembly from Rear

- 2) On the left upright, there is a horizontal hole through the width of the upright just below the slot for the beater top. This hole is offset to the front of the shuttle race side of the upright.
- 3) Take a 5/16" x 5" hex bolt with a washer on it, insert it through the hole in the upright from the inside through the nut access hole in the upper right corner of the drop box assembly. Thread a square nut onto the bolt.

- 4) Do not tighten this yet. Your drop box assembly should now be attached to the upright with this one bolt with the moveable boxes in the front.
- 5) Attach the drop box assembly to the shuttle race with two 5/16" x3" carriage bolts inserted from the front with washers and hex nuts behind the back plate.

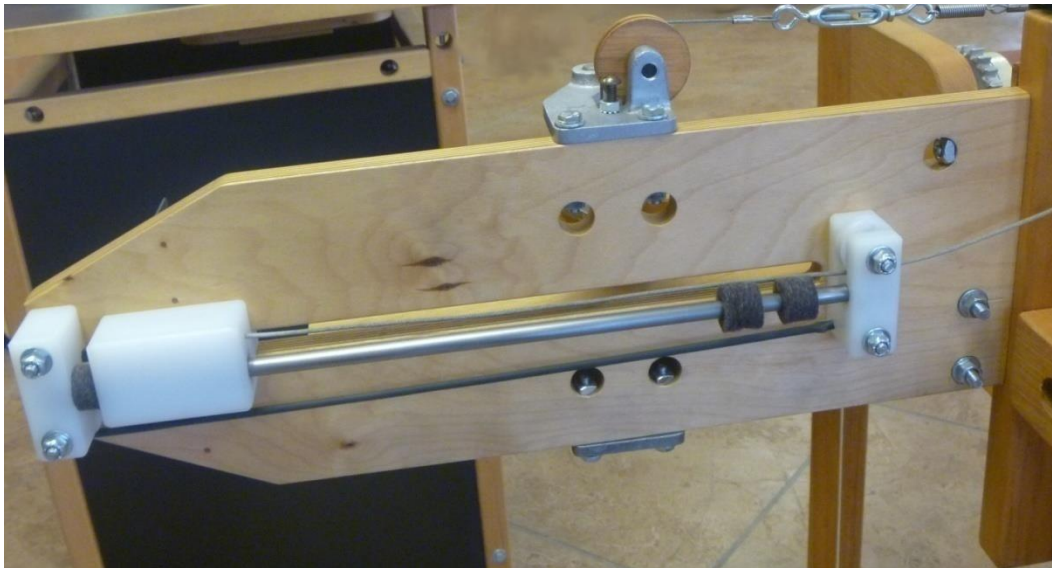

Figure 15 - Flyshuttle Box from back

- 6) Now tighten all bolts holding the drop box assembly to the beater.

IMPORTANT:

The face of the back plate must be precisely flush with the face of the upright. Check this alignment by laying a straight edge across the two surfaces.

- 7) Repeat this procedure for the right drop box assembly.

Assemble the Picker Cylinder and Picker Stick

The Picker Stick Assembly consists of the picker stick attached to a wooden piece with nut access holes on the opposite end from the picker stick.

- 1) The Picker Stick is attached to the green picker on your flyshuttle box.
- 2) Place the nut access holes on the attached wooden piece against the corresponding holes on the upright and attach it with carriage bolts.

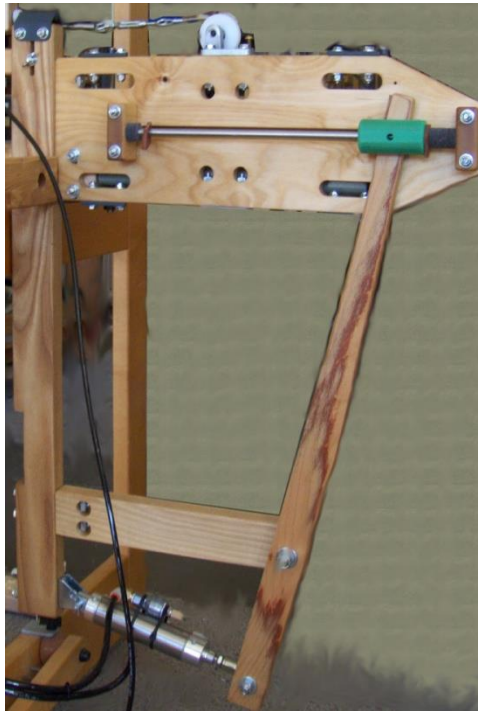

Figure 16 - Picker Stick Assembly

- 3) Find the picker cylinder.
- 4) Place one end of the picker cylinder on the bracket on the upright. Place the pin through the bracket and the picker cylinder and secure it with a clevis pin.
- 5) Bolt the other end of the picker cylinder to the end of the picker stick.



Figure 17 - Picker Cylinder

Adjust the movement of the dropboxes

Note:

You can adjust the movement of the boxes both with the adjustment screw and with the turnbuckle on the shift handle cables. Adjust each as needed until the boxes are in the correct position.

The boxes slide up and down on a metal rod which is fixed at both ends to cast metal pieces in order to change the box. There is a brass adjustment screw with a lock nut. These brass screws provide a stop for the boxes at their upper and lower extremes of movement.

- 1) Adjust the top screw so that when the boxes are all the way up, the lower box is in precise alignment with the shuttle race.
- 2) Adjust the bottom screw so that when the boxes are all the way down, the upper box is in precise alignment with the shuttle race.

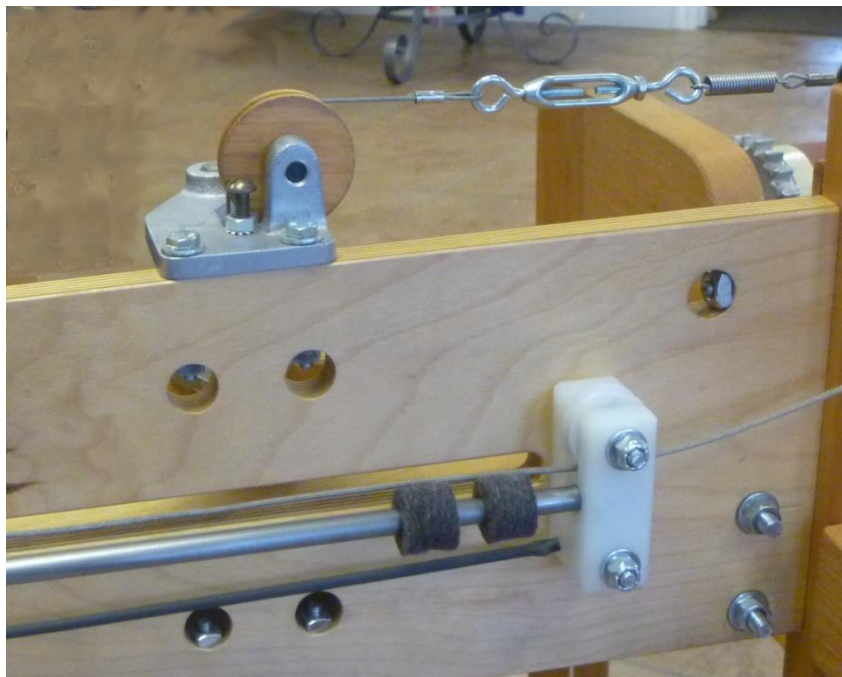

Figure 18 - Flyshuttle adjustment screw

Note:

This adjustment is critical. Please make it carefully. It is wise to lay a straight edge across the shuttle race and drop box when doing this to assist you in getting the two perfectly aligned.

- 3) When you have it properly adjusted, secure the lock nuts on the brass screws. Do these adjustments on both the left and right drop boxes. If your shuttle flight is erratic, re-check these adjustments.
- 4) To make sure that the adjustment screws stay in place, you might want to purchase a small tube of a thread locking agent (such as Loctite) and apply a drop or two to each of these screws where the screws go into the cast metal brackets.

MOUNT THE AIR SYSTEM

- 1) Unpack the box of components and tubing. Locate and layout the components and tubing inside the loom in their general locations.

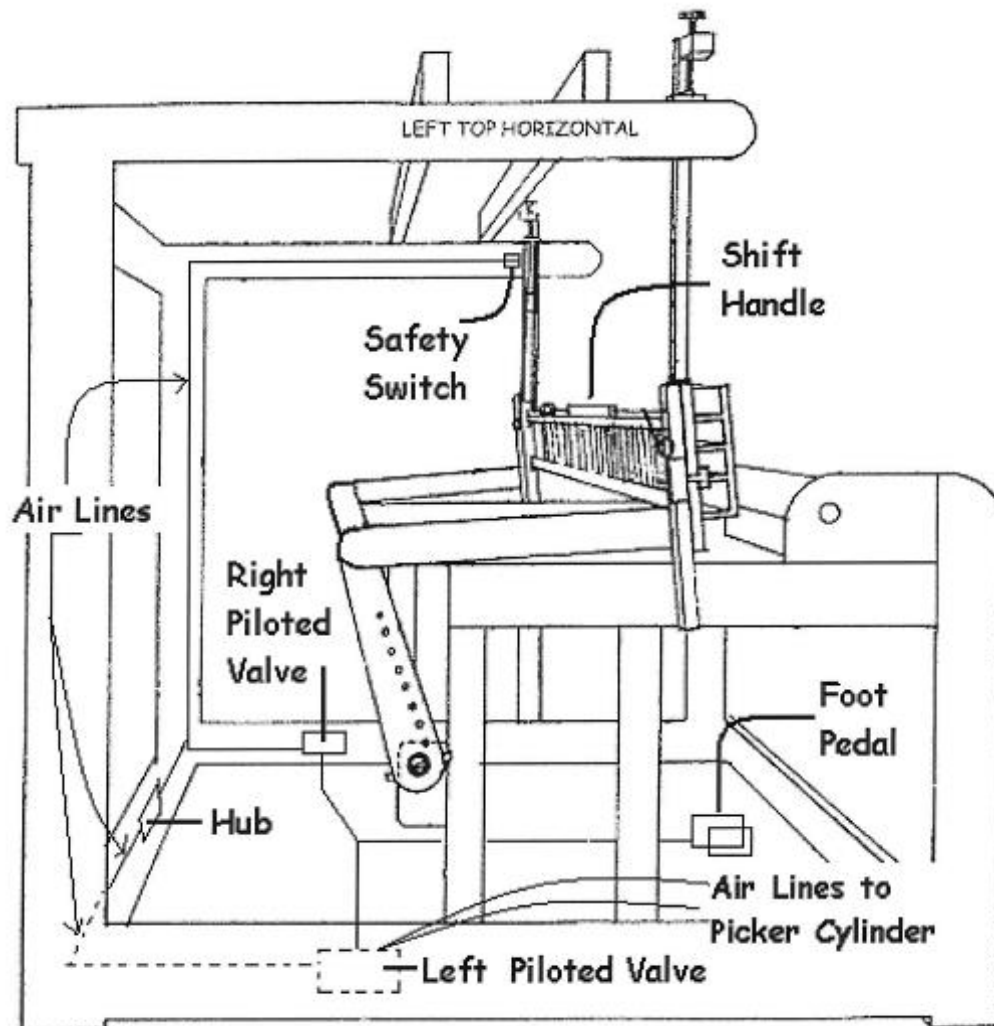

Figure 19 - Air Tubing Diagram

- 2) Mount the plastic tie-downs and secure them to the loom with #6 x 1/2" screws provided.

ATTACH THE AIR SHUTTLE SWITCH

You will have a switch on the shift handle activate the shuttle.

Install the shift handle switch

- 1) Loosen the wing nuts that keep the beater top in place and remove the beater top. Let it lay across the loom frame where it will be out of the way but handy.
- 2) The shift handle on the beater top is fastened from the bottom with two screws. Loosen these screws and remove the handle.
- 3) Locate the switch housing and remove the black base plate.
- 4) Remove the silver plate holding the rocker switch to the front of the housing by unscrewing four small screws.
- 5) Select two #10-32 x 3/8" screws from your hardware pack. Then reattach the shift handle to the top of the housing. Be sure to orient the handle so that the screw eyes with cables are to the rear.
- 6) Replace the rocker switch and plate.
- 7) Replace the black base plate on the switch housing orienting the two threaded holes toward the open cavity on the back of the switch housing.
- 8) Use the four screws to secure the base to the housing. Four-box assemblies will have six screws.

Mount the switch housing/shift handle assembly

- 1) Locate the two shift handle mounting screws provided.
- 2) Retrieve the beater top.
- 3) Attach the two (or three) #10 x 7/8" FHMS screws through the bottom of the beater top.
- 4) Align the switch assembly over the screws with the switch to the front.

- 5) Replace the beater top.



Figure 20 - Shift Handle Switch

- 6) On each side there is a cable attached to the drop box which has an eyebolt on the end. This cable is routed over the top of the drop box pulley and the eyebolt threads into the turnbuckle on the end of the cable coming from the shift handle.

MOUNT THE LEFT AND RIGHT PILOTED VALVES

The Piloted Valves will be secured to the inside of the left and right Bottom Horizontals. They are already affixed to their mounting brackets. If you followed the previous instructions, you've already placed the valves on the floor near their mounting places.

- 1) Measure from the FRONT of the bottom horizontal 32-1/2" to establish the centerline of your mounting bracket. Make a light vertical pencil line.

Note:

Make sure to measure from the front of the bottom horizontal rather than from the front of the loom.

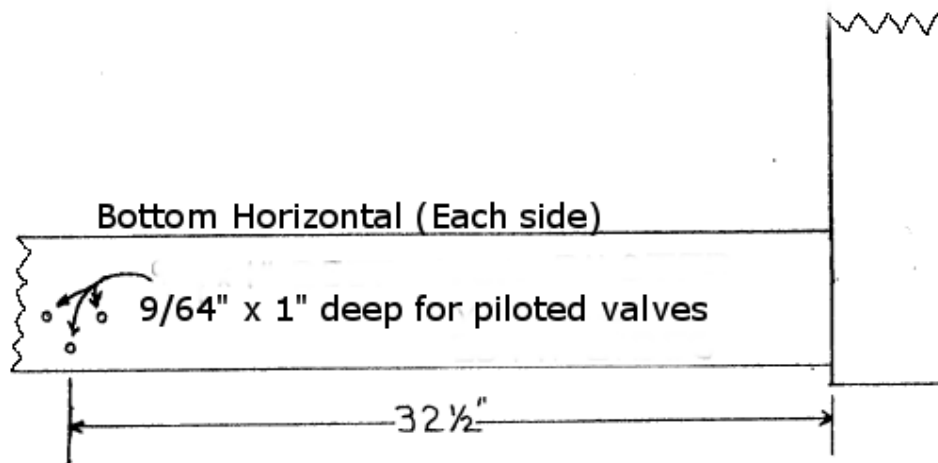

Figure 21 - Piloted Valve Mounting Location

- 2) Each bracket has a triangular set of three holes. Place the bottom hole over your pencil line with the bottom of the bracket flush to the bottom of the horizontal and mark each hole.
- 3) Drill a 9/64" hole 1" deep at each marked location.
- 4) Select three #8 x 1" pan head sheet metal screws from the hardware pack and use them to mount the left Piloted Valve in the holes on the left bottom horizontal.
- 5) Repeat for the right valve.



Figure 22 - Piloted Valve

- 6) Matching the color coding tape, connect the plastic tubing from the Piloted Valve to the picker stick cylinder on each side.

INSTALLING THE FRL AND MANIFOLD

All of the Air components require a Filter/Regulator (FRL) to be installed on the loom. This component connects the air compressor to the air components on your loom. Depending on the configuration of your loom, the FRL may differ from what is shown here.

- 1) Find the FRL. It will have a network of tubing attached to it. Remove the silver bracket from the FRL by unscrewing the collar.
- 2) Measure up the outside center of the left rear side support. Predrill two mounting holes $9/64$ " diameter and 1" deep for the FRL using a $9/64$ " bit.

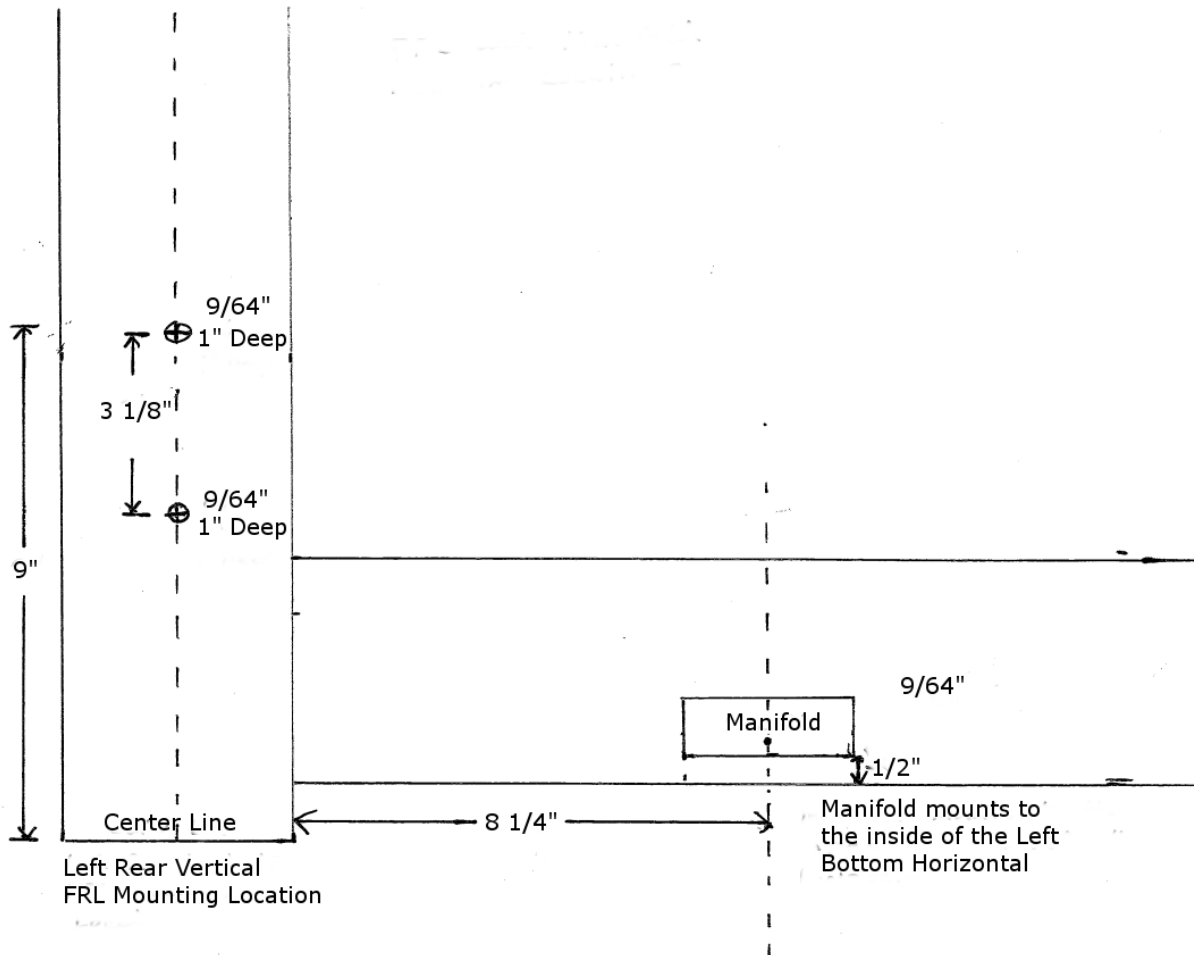

Figure 23 - FRL and Manifold Mounting Locations

- 3) Install the Filter/Regulator (FRL) in the holes you just drilled onto the left rear side support using the screws provided.

- 4) Connect the FRL to the correct color coded air line from the coil of tubing with the air cylinder. The air lines have been connected to their fittings by pushing them into place. They will not come out. In fact, the harder you pull, the harder it will hold.

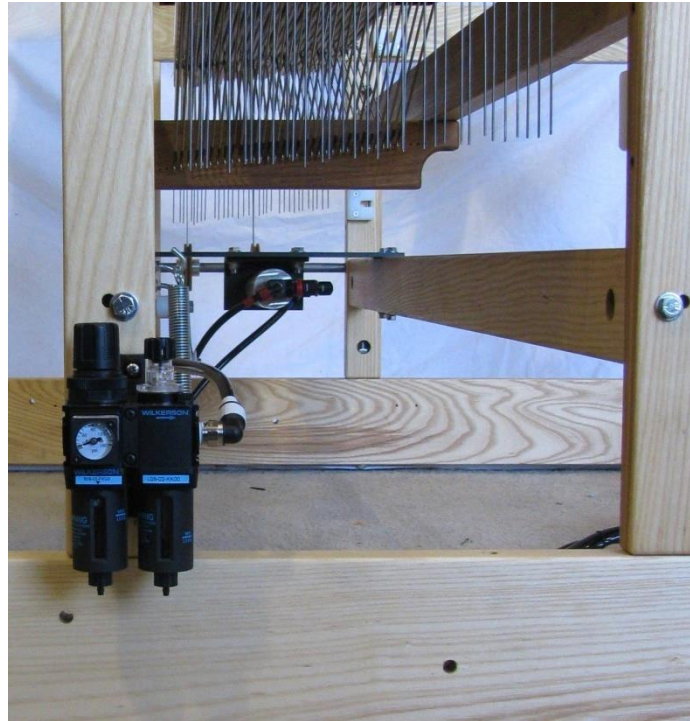

Figure 24 - FRL Placement

Install the Manifold

- 1) Measure as shown in Figure 23 - FRL and Manifold Mounting Locations from the left rear vertical to the manifold position on the left bottom horizontal. Mark the center line for the manifold.
- 2) Hold the manifold 1/2" from the bottom of the left bottom horizontal with the center on the line you just drew.
- 3) Mark the hole for the bottom screw, on the center line. Drill the hole and temporarily attach the manifold with just the bottom screw.
- 4) Mark the remaining attachment holes.
- 5) Remove the manifold and drill the remaining holes.
- 6) Attach the manifold in position using the screws.

MOUNT THE SAFETY VALVE

The Safety Valve will prevent your shuttle from firing unless the Beater is in its rearmost position. It is activated by contact with the Beater and must be correctly installed and adjusted if it is to work properly. It will mount on the right top horizontal or to the right lower cloth beam support. There should be a small metal plate clipped to your valve assembly. This is a striker plate. It provides wear protection to the beater leg or upright.

- 1) Use the 9/64" bit to drill three holes 1" deep on the inside of the right top horizontal.

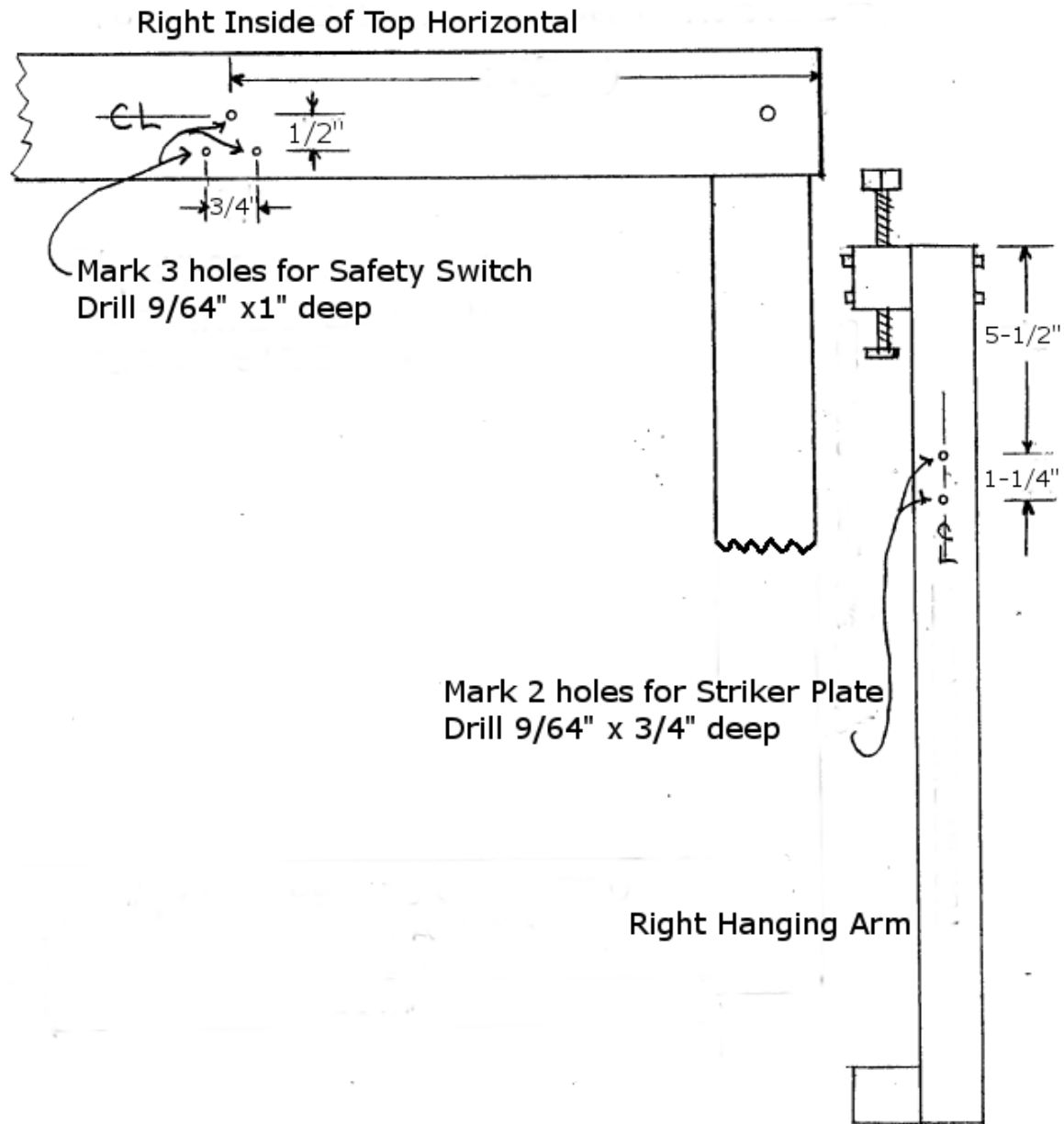

Figure 25 - Safety Valve Mounting Location

- 2) Locate your Safety Valve. It consists of a mounting bracket, a brass block with several fittings, a small spring loaded arm, and the striker plate.
- 3) Position the valve so that the small metal arm points to the front of the loom. The ninety degree connector on the top of the valve will point to the inside of the loom.



Figure 26 - Safety Valve

- 4) Use three #8 x 1" pan head screws to secure the valve to the Right Top Horizontal.
- 5) Place the striker plate on the back of the right hanging arm, immediately opposite the Safety Valve. The small plastic wheel on the valve arm should strike the plate at about its center. Mark and drill two holes with your 9/64" bit and mount the plate using two #8 x 3/4" flat head screws from the hardware pack.

Adjust the Safety Valve

Important:

You will still need to adjust the position of the safety valve relative to the beater. This adjustment is essential to safe operation.

- 1) Use your 5/32" allen wrench to loosen the two allen screws on the outside of the valve body. This will allow you to move the valve forward or backward.
- 2) Move the valve to the far left side of its bracket (towards the back of the loom).
- 3) Push your beater to its rearmost position (away from the weaver).
- 4) Now move the Safety Valve back towards the beater leg or hanging arm.
- 5) You want to locate the valve so that the plastic wheel on the valve arm contacts the strike plate.
- 6) Continue to move the valve until the small plunger in the valve body is fully depressed.

- 7) Hold the valve in this position and retighten the allen screws. You may need to move the beater forward to relieve tension on the valve while you secure it.
- 8) Move the beater back again and see that the valve is still correctly positioned.
- 9) If the Safety Valve is working properly, the shuttles will only fire when the beater is pushed all the way back. Test with the beater in both positions.

Note:

DO NOT USE YOUR SYSTEM UNLESS THIS DEVICE IS IN PLACE AND OPERATING.

AIR DOBBY OR AIR LIFT INTERFACE

An Air Dobby or Air Lift is an optional feature for the Loom that uses compressed air to lift the harnesses rather than treadles or an E-lift. If you have an Air Dobby or Air Lift currently on the loom, an interface is included with the Air Shuttle System to allow you to connect the air system properly.

If you have an air dobbie or air lift, follow these instructions to connect the air system.

- 1) Install the 3/8" tee fitting 4" from the main air regulator at the FRL.
- 2) Connect the main air lines from the air dobbie foot pedal and air shuttle to openings on the tee.

CONNECTING THE COMPONENTS TO COMPRESSED AIR

Your loom is now ready to be hooked up to a compressed air line. This line will be connected to the FRL unit. You need to purchase a fitting to hook up to your air line. For convenience, we suggest that you use a "quick disconnect" type fitting which can easily be released from the loom without any tools. You will need to buy a male fitting with either 1/4" or 3/8" pipe threads to thread into the FRL. A corresponding *female* connector will be needed for the hose end.

Add Oil to the FRL

Oil needs to be added to the FRL periodically for the cylinders. A very low flow of oil to the cylinders is sufficient so the oil will only need to be refilled occasionally.

The oil should be F442 oil. This is a non-detergent, non-solvent, turbine-quality oil that will prevent early deterioration of the seals of the air system.

Note:

Add oil to the FRL before running the air system.

- 1) Fill the oil cup on the FRL to the maximum fill line.
- 2) Tighten the finger adjuster screw on top finger tight, then just crack it open.

Adjust the air pressure

- 1) Once the loom has been hooked up to an air line, set the regulator to a pressure range that will operate the cylinder to your satisfaction. Start at 40 to 50 PSI.
- 2) The air shuttle can now be activated with the switch on the handle. See page 26 for installation instructions if needed. The speed of the shuttle can be further altered by adjusting the flow control valves.

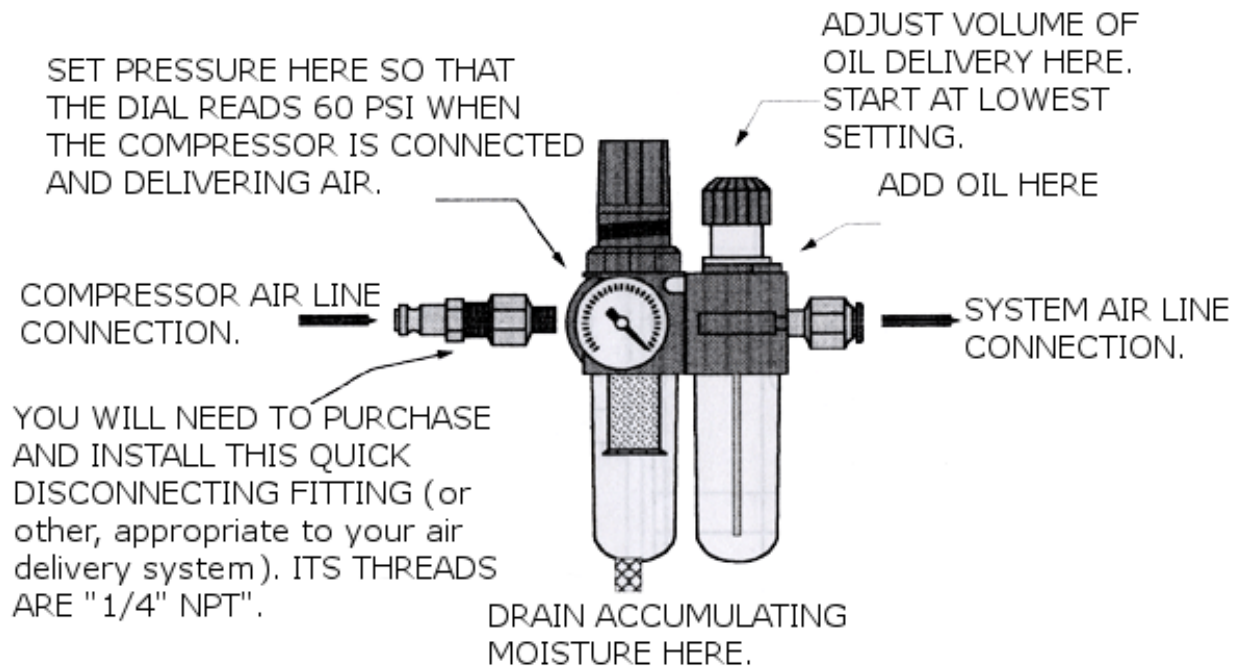

Figure 27 - FRL Detail (may vary)

AIR SHUTTLE OPERATION

Before using your air shuttle, make sure that:

- The main air line is connected to the FRL.
- The safety valve is installed and adjusted.
- The air pressure at the FRL is set.
- Each of the Piloted Valves is adjusted to a low air pressure setting (40 p.s.i.).

- 1) Load the boxes with shuttles.
- 2) Use your shift handle to select a shuttle.
- 3) Treadle to create a shed.
- 4) Push the Beater back against the Beater Bumper Blocks.
- 5) Depress the plastic rocker switch (or foot pedal).
- 6) The shuttle will fly across the race into the opposite box.

If you have a problem, it will likely be in the travel of the shuttle. You may need to increase the pressure at the Piloted Valves or adjust the tension in the binder clips.

BINDER CLIP TENSIONING

The wooden binder blocks, in the sides of your drop boxes, act to brake your shuttle and keep it properly positioned. These blocks are kept under tension by thin strips of spring steel, two per block. If the binders are properly adjusted, the shuttle will come into the box and will not rebound. If a block is under too much tension, it will impede the travel of the shuttle so that it doesn't cover the full length of the race.

Much depends on the speed of the shuttle which in turn depends on the amount of air pressure in your system. Make adjustments to air pressure before adjusting the binder clips. You'll need to make a few shots in order to assess the behavior of each binder. If you need to adjust the binder clips, follow these instructions.

Note:

PLEASE TAKE CARE NOT TO CUT YOURSELF.

- 1) Slip the clips that hold the block out of their holding brackets.

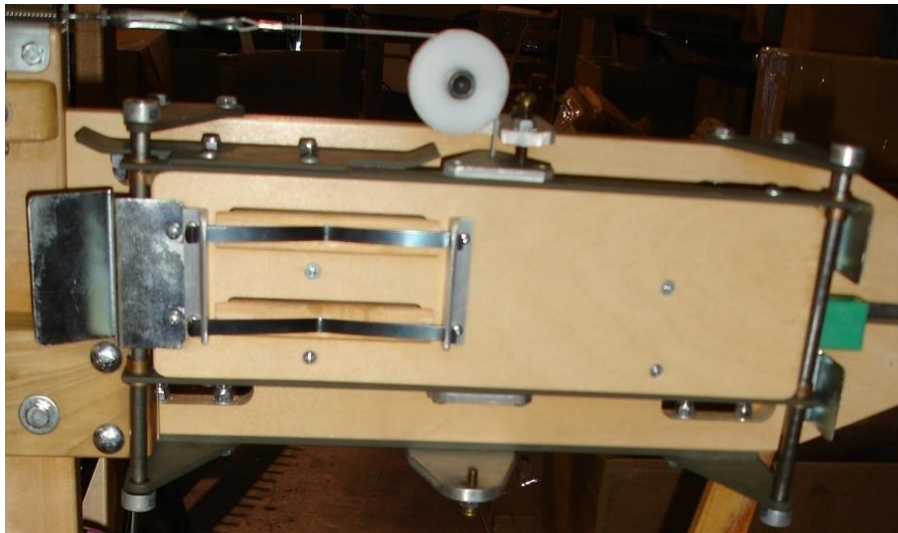

Figure 28 - Binder Clips

- 2) If you need more tension, slightly increase the degree of bend in each clip. If you need less, decrease the bend.

- 3) As an alternative, you may decrease tension by removing one of the clips.
- 4) Again, check the action of your shuttle against the newly tensioned block. Continue to adjust as necessary.

CALIBRATING

In addition to the few mechanical adjustments you just made, you'll need to make some settings at your FRL and at both your Piloted Valves. The regulator on the FRL controls the air pressure in the system. The Piloted Valves control the action of the pickers and allow you to fine tune the speed at which they deploy your shuttles.

Before you can make these calibrations, you'll need to have connected the FRL to your compressor. See the section on connecting your components on page 34.

The Air Pressure

Look closely at the FRL. There is a large cone-shaped knob on the top left side. This knob regulates the air pressure in the system. The amount of this pressure is indicated by the gauge at the front of the unit.

We will assume that your compressor is now delivering air to your FRL.

Adjust the knob until the gauge reads 70 p.s.i. This is a good starting position.

The Piloted Valves

You'll find a regulator at the Piloted Valves and a pressure gauge immediately adjacent. This is where you set the speed of your shuttles.

- 1) Pull the yellow locking ring up and turn the knob. As with all these settings, you'll need to play around a bit until you've tuned the system to your particular need. We recommend that you begin with a pressure setting of 40 p.s.i. If the shuttle doesn't make it completely across the race, increase the pressure (or loosen the binder clips). If it bounces out of the box, decrease pressure (or tighten the clips).
- 2) When you've finally found the pressure setting that works best, reset the locking ring.

MAINTAINING YOUR SYSTEM

- 1) Check the FRL weekly (if you use your loom daily).
 - a. Drain the filter bowl if you note a buildup of condensation. There's a drain plug at the bottom of the bowl.
 - b. Check the oil level. Refill when the oil is at the minimum line.
- 2) Wipe the shuttle box slide rods clean of lint.
- 3) Wipe the picker slide rods clean of lint regularly.
- 4) The shift handle may get sticky after a while. A lubricating spray can be applied to the pivot mechanism. Periodically blowing or brushing lint out is recommended.
- 5) Check and tighten the bolts as needed.
- 6) Adjust the various mechanisms as needed.

NOTE:

Please disconnect the air from your compressor before you drain your system.



THE FINE PRINT

AVL CUSTOMER SERVICE

AVL offers free technical support to the original owner of all our looms. This means if you ever have a problem, you can call, fax, or e-mail us and we'll help you find a solution. Please take advantage of this service; your satisfaction is extremely important to us.

Customer Service Phone: (530 893-4915)

Fax: (530) 893-1372

E-Mail: sales@avlusa.com

AVL WARRANTIES

Limited Warranty: The benefits of this warranty accrue solely to the original purchaser of AVL Looms, Inc. products, as defined below.

Your warranty covers:

New Looms: AVL Looms, Inc., a California corporation ("AVL") warrants to the original purchaser of any AVL loom (each, a "Product") that the Product will be free from defects in materials and workmanship during the limited warranty period described herein. The limited warranty coverage begins (a) the day the Product is installed if installed by a professional from AVL, or (b) on the date of shipment from AVL to the original purchaser if the Product is not installed by AVL (the "Effective Date"). Except as set forth under the section entitled "What is Excluded?" below, AVL will, for a period of two (2) years from the Effective Date (the "Original Warranty Period"), repair or replace the defective part(s) of the Product with a repaired, renewed, or comparable part (whichever is deemed necessary or proper by AVL) if it becomes defective or inoperative or fails to perform according to AVL's specifications. Any repair during the Original Warranty Period will be carried out without charge to you for parts (except applicable taxes, if any). You will be responsible for all labor in connection with installation of the parts and service upon the Product, as well as the cost of shipping involved.

New Accessories, Loom Upgrade Parts, and Replacement Parts: Subject to the limitation contained in subsection (i) under the section entitled "What is Excluded?" below, AVL warrants to the original purchaser of any accessory, loom upgrade parts, or loom replacement parts (the "Additional Part") that are sold by AVL that such Additional Part will be free from defects in materials and workmanship for ninety (90) days from the date of purchase. In the event that any Additional Part is physically damaged or physically defective and if such defective Additional Part is returned to AVL within ninety (90) days of the date of purchase, AVL will provide a replacement Additional Part at no charge. The sole remedy for this warranty shall be limited to the replacement of the defective Additional Part. You are responsible for all shipping charges (including applicable taxes) incurred with returning the defective Additional Part.

All New Products and their components (including replacement Product and its components) are covered only for the Original Warranty Period. When the warranty on the original Product expires, the warranty on any replacement Product, or components also expires. After two (2) years from the Effective Date, you pay for any replacement or repair, including all parts, all labor and shipping charges (including applicable taxes).

Your warranty does not cover:

1. Labor charges for installation or set-up of the Product, as well as any labor charges required to install, disassemble, troubleshoot, or reassemble the Product.
2. Any taxes imposed on AVL for Product replacement or repair under this warranty.
3. Installation, performance of, or repair of: cabling, electrical, or accessory attachments used with the Product.
4. Product replacement or repair because of misuse, accident, repair by any party other than AVL, or other cause not within the control of AVL. Please note that removing any parts from the Product for any reason voids the warranty.
5. Incidental or consequential damages resulting from the Product.
6. A Product that has been modified or adapted to enable it to operate in any country other than the United States or any repair of Products damaged by these modifications.
7. Electrical and pneumatic components, each of which carries a one (1) year warranty from the Effective Date.
8. Jacquard components function beyond 98%. A Jacquard module is considered to be operating within specification if 98% of all hooks are operating as commanded.
9. Computing equipment, such as a Personal Digital Assistant or a Personal Computer, which are manufactured by a third party(ies) and which may be under warranty through the original manufacturer. AVL is not responsible for any warranty coverage that may be offered concerning these products and you must contact those manufacturers directly regarding any available warranty coverage.

The performance or functionality of any software that is sold either together or separate from the Product. The AVL warranty covers only defects in the Software Media, namely the CD-ROM media such as a broken CD-ROM or a defect in the CD-ROM that would prevent the CD-ROM from being read by your personal computer's CD-ROM drive. ,

AVL Returns Policy

Any order that has left AVL in transit to the customer is considered fulfilled. Parts and accessories not covered under warranty must be returned to AVL within 60 days from the date of shipment from AVL. The purchase price of the item(s) is refundable less a 15% re-stocking fee based on the total purchase price. No refunds will be given on shipping or handling. The buyer is responsible to return the merchandise in "as new" condition at their expense. Any item received showing wear or damage is not eligible for return and will be promptly returned to the customer COD unless some other arrangement is made. Looms and custom-made items, special order items, parts made for pre-1998 looms, used and reconditioned items are not eligible for return.