

KU20

LED Display Controller



Specifications

Change History

Document Version	Release Date	Description
V1.0.0	TBD	First release

Introduction

The KU20 is an LED display controller with 6 Ethernet ports in the brand-new control system COEX series of Xi'an NovaStar Tech Co., Ltd. (hereinafter referred to as NovaStar). This controller offers 1x HDMI input, 6x Ethernet outputs and 1x optical output. It can also work with the brand-new software VMP (Vision Management Platform) to provide a better operation and control experience.

Certifications

CCC, CE, FCC, IC, UL, CB, PSE, RCM

If the product does not have the relevant certifications required by the countries or regions where it is to be sold, please contact NovaStar to confirm or address the problem. Otherwise, the customer shall be responsible for the legal risks caused or NovaStar has the right to claim compensation.

Features

Inputs and Outputs

- HDMI input
1xHDMI 1.3 (with loop through)
- 10-bit and 8-bit video inputs
- Ethernet outputs
6 Ethernet outputs, up to 2.3 million pixels supported
- Optical output
One10G optical output

Advanced Features

- Full Grayscale Calibration
Work with NovaStar's high-precision calibration system to generate unique calibration coefficients for each grayscale, ensuring uniformity of each grayscale and improving the screen's image quality.
- Pixel level brightness and chroma calibration
Work with NovaStar's high-precision calibration system to calibrate the brightness and chroma of each pixel, effectively eliminating brightness differences and chroma differences, and enabling high brightness consistency and chroma consistency.
- Latency
 - Support low latency. The latency at the controller is 0 frame (less than 1 ms) and the load capacity is not reduced.
 - Support additional latency. Zero to two frames of latency can be added at the controller.
- Input frame rate adaptive
The controller can be adaptive to various video input frame rates, including decimal frame rates. Custom frame rates are also supported and the frame rate can be adjusted in 0.01 Hz.
- Display system monitoring
Support monitoring of device status and screen status. Any fault and alarm information can be reported actively

Device Controls

- VMP software control
The device can be connected to the VMP software to provide easy and convenient operations and smart device management.
- Cascading control via Ethernet
The Gigabit Ethernet control ports support TCP/IP protocol and star topology. No switch is needed to cascade control of multiple devices as a network switch is already built in.

Video Sources

Input	Bit Depth	Sampling Format	Max Input Resolution
HDMI 1.3	8bit/10bit	RGB 4:4:4	1920x1200@60Hz
		YCbCr 4:4:4	
		YCbCr 4:2:2	

Note

The controller must work with the A10s Pro to realize the function of adaptive input frame rate. Currently supported driver ICs include MBI5264, ICND2055, ICND2065, ICND2059 and ICND2069.

Appearance

Front Panel



Name	Description
Running Indicator	<ul style="list-style-type: none"> • Solid red: Standby • Solid blue: The device is being powered on. • Solid green: The device is running normally. • Flashing red: The device is running abnormally.
Standby Button	<ul style="list-style-type: none"> • Press the button to power on or power off the device. • Hold down the button for 5s or longer to restart the device.
USB 2.0	Used to send cabinet configuration files and export the diagnostic result
LCD Screen	A 2.0-inch screen that displays the device status, menus, submenus and messages for parameter settings
Knob	<ul style="list-style-type: none"> • On the home screen, press the knob to enter the main menu screen. • On the main menu screen, rotate the knob to select a menu item or adjust the parameter value. Press the knob to confirm the operation.

Name	Description
	<ul style="list-style-type: none"> Hold down the knob and BACK button simultaneously for 5s or longer to lock or unlock the buttons.
BACK	Go back to the previous menu or cancel the current operation.

Rear Panel

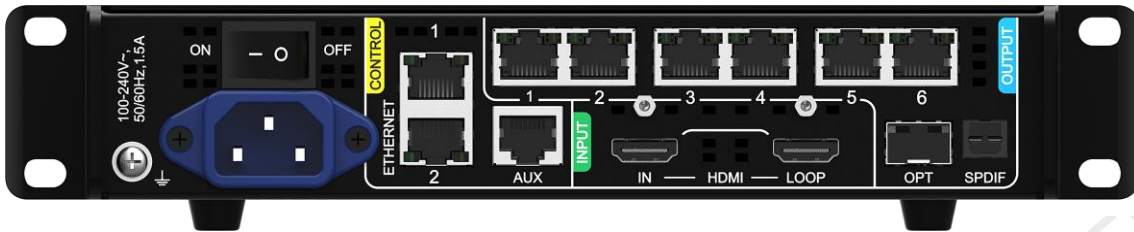

Inputs (INPUT area)			
Type	Qty	Description	
HDMI IN	1	Resolutions	Max resolution: 1920x1200@60Hz Min resolution: 800x600@60Hz
		Max width/height	Max width: 3840 (3840x600@60Hz) Max height: 2560 (800x2560@60Hz)
		Frame rates	23.98/24/25/29.97/30/47.95/48/50/59.94/60/71.93/72/75/100/ 119.88/120 Hz
		EDID management	Support standard resolutions, up to 1920x1200@60Hz. Support custom input resolutions.
		HDCP	HDCP 1.4 compliant
		Interlaced signal inputs	Not supported
Outputs (OUTPUT area)			
Type	Qty	Description	
1–6	6	Gigabit Ethernet output ports. Support hot backup between Ethernet ports. Max load capacity per port: <ul style="list-style-type: none"> 8bit@60Hz: 650,000 pixels 10bit@60Hz: 325,000 pixels. When the controller works with the A10s Pro receiving card, the capacity can be up to 480,000 pixels. 	
OPT	1	10G optical output port	
HDMI LOOP	1	HDMI loop through	
SPDIF	1	A digital audio output (Reserved)	
Controls (CONTROL area)			
Type	Qty	Description	
ETHERNET	2	Gigabit Ethernet control ports. Support TCP/IP protocol and star topology. They have the same functions without priority and order, and can be connected to VMP software. No switch is needed to cascade control of multiple devices as a network switch is already built in.	
AUX	1	An auxiliary connector that connects to the central control device (RS232) (Reserved)	
Power			
100-240V~, 50/60Hz, 1.5A	1	An AC power input connector and switch	

Dimensions

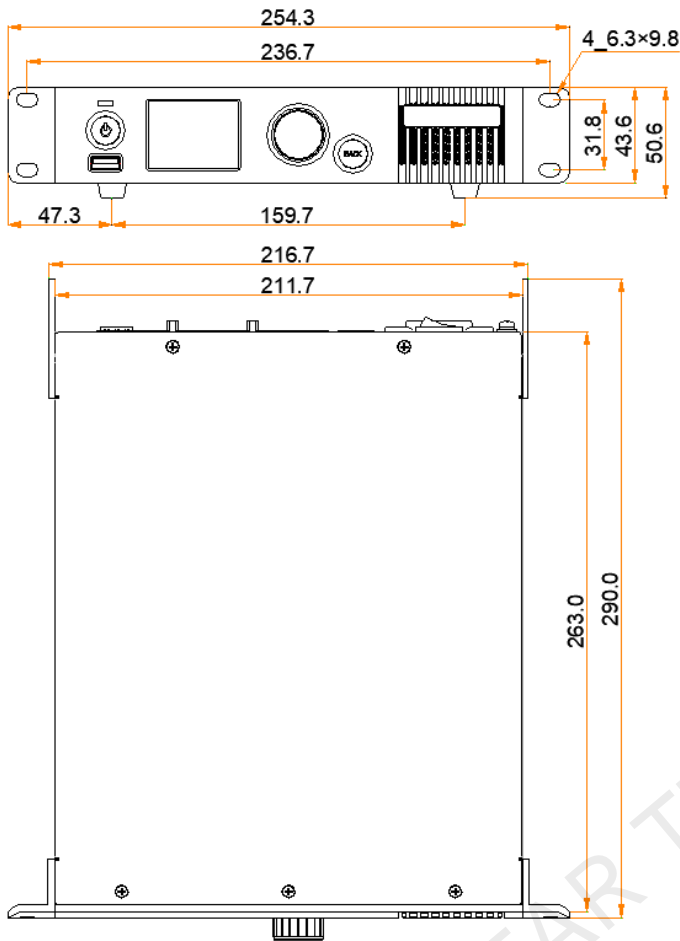

Tolerance: ± 0.3 Unit: mm

Assembling Effect Diagram

A single KU20 device is half-1U in width. Two KU20 devices, or one KU20 device and a connecting piece can be combined into one assembly that is 1U in width. The assembly can be mounted in a standard 19-inch rack.

Assembly of Two KU20

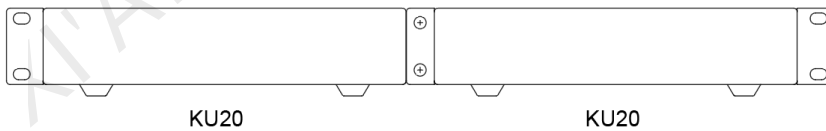

Assembly of a KU20 and a Connecting Piece

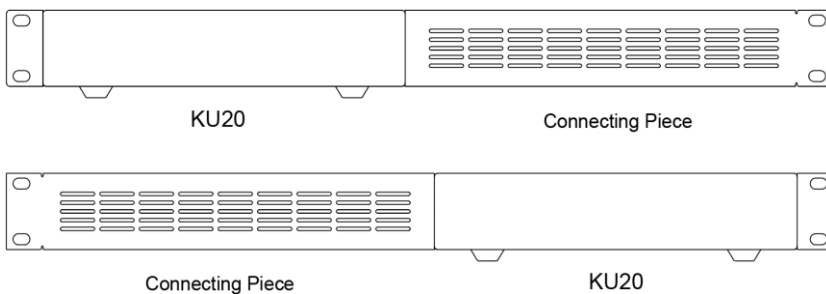

Specifications

Electrical Specifications	Power input	100-240V~, 50/60Hz, 1.5A
	Max power consumption	25 W
Operating Environment	Temperature	-20°C to +50°C
	Humidity	0% RH to 80% RH, non-condensing
Storage Environment	Temperature	-30°C to +80°C
	Humidity	0% RH to 95% RH, non-condensing
Physical Specifications	Dimensions	254.3 mm × 50.6 mm × 290.0 mm
	Net weight	2.1 kg
	Gross weight	3.1 kg Note: It is the total weight of the product, accessories, and packing materials packed according to the packing specifications.
Packing Information	Outer box	387.0 mm × 173.0 mm × 359.0 mm, kraft paper box
	Packing box	362.0 mm × 141.0 mm × 331.0 mm, white cardboard box
	Accessories	<ul style="list-style-type: none"> • 1x Power cord • 1x Ethernet cable • 1x HDMI cable • 1x Certificate of Approval
IP Rating	IP20 Please prevent the product from water intrusion and do not wet or wash the product.	

The amount of power consumption may vary depending on various factors such as product settings, usage, and environment.

Notes for Battery

- The battery is not intended to be replaced.
- Disposal of a battery into fire or a hot oven, or mechanically crushing or cutting of a battery can result in an explosion.
- Leaving a battery in an extremely high temperature surrounding environment can result in an explosion or the leakage of flammable liquid or gas.
- A battery subjected to extremely low air pressure may result in an explosion or the leakage of flammable liquid or gas.

Notes for Installation

When the product needs to be installed on the rack, 4 screws at least M5*12 should be used to fix it. The rack for installation shall bear at least 9kg weight.

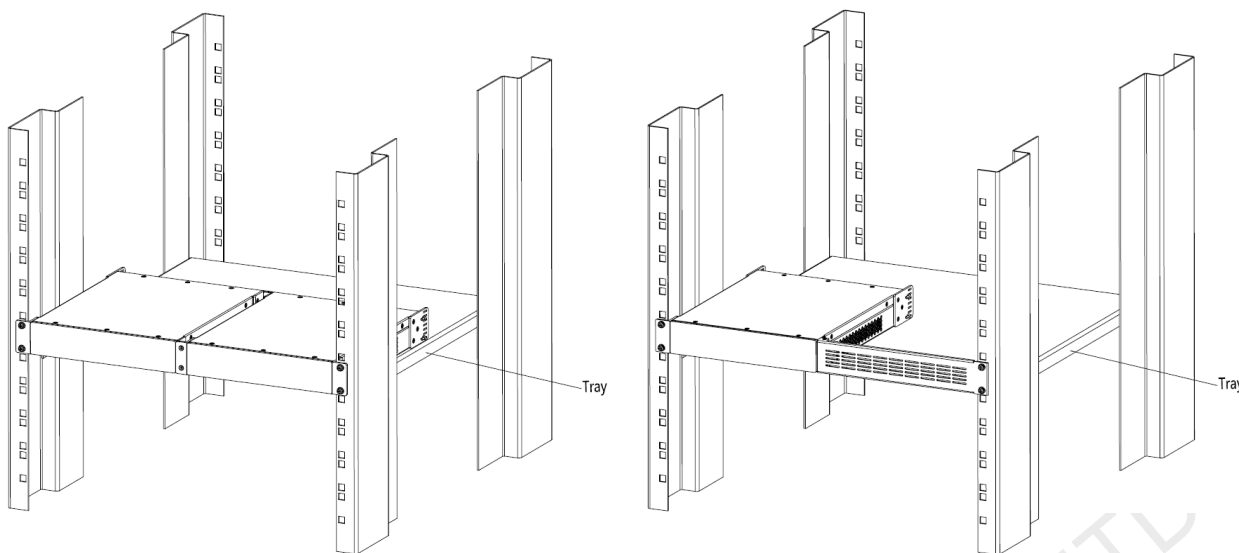

- Elevated Operating Ambient - If installed in a closed or multi-unit rack assembly, the operating ambient temperature of the rack environment may be greater than room ambient. Therefore, consideration should be given to installing the equipment in an environment compatible with the maximum ambient temperature (Tma) specified by the manufacturer.
- Reduced Air Flow – Installation of the equipment in a rack should be such that the amount of air flow required for safe operation of the equipment is not compromised.
- Mechanical Loading – Mounting of the equipment in the rack should be such that a hazardous condition is not achieved due to uneven mechanical loading.
- Circuit Overloading – Consideration should be given to the connection of the equipment to the supply circuit and the effect that overloading of the circuits might have on overcurrent protection and supply wiring. Appropriate consideration of equipment nameplate ratings should be used when addressing this concern.
- Reliable Earthing – Reliable earthing of rack-mounted equipment should be maintained. Particular attention should be given to supply connections other than direct connections to the branch circuit (e.g. use of power strips).

FCC Caution

Any changes or modifications not expressly approved by the party responsible for compliance could void the user's authority to operate the equipment.

This device complies with part 15 of the FCC Rules. Operation is subject to the following two conditions: (1) This device may not cause harmful interference, and (2) this device must accept any interference received, including interference that may cause undesired operation.

Note: This equipment has been tested and found to comply with the limits for a Class A digital device, pursuant to part 15 of the FCC Rules. These limits are designed to provide reasonable protection against harmful interference when the equipment is operated in a commercial environment. This equipment generates, uses, and can radiate radio frequency energy and, if not installed and used in accordance with the instruction manual, may cause harmful interference to radio communications. Operation of this equipment in a residential area is likely to cause harmful interference in which case the user will be required to correct the interference at his own expense.

Others

This product can only be placed horizontally. Do not mount vertically or upside-down.

This is Class A product. In a domestic environment, this product may cause radio interference in which case the user may be required to take adequate measures.

Copyright © 2022 Xi'an NovaStar Tech Co., Ltd. All Rights Reserved.

No part of this document may be copied, reproduced, extracted or transmitted in any form or by any means without the prior written consent of Xi'an NovaStar Tech Co., Ltd.

Trademark

NOVA STAR is a trademark of Xi'an NovaStar Tech Co., Ltd.

Statement

Thank you for choosing NovaStar's product. This document is intended to help you understand and use the product. For accuracy and reliability, NovaStar may make improvements and/or changes to this document at any time and without notice. If you experience any problems in use or have any suggestions, please contact us via the contact information given in this document. We will do our best to solve any issues, as well as evaluate and implement any suggestions.

Official website
www.novastar.tech

Technical support
support@novastar.tech