

Pixie Air™ Series

WHISPER POWER

30" UNDER-CABINET RANGE HOOD (Convertible)

Models: **UQS3001, UQG3002**

FOTILE's Pixie Air Range Hoods are sleek and ultra-slim that blend seamlessly into your kitchen with a clean low profile. Powerful Dual WhisPower motors and Captur-Shield technology remove smoke, grease, and odors effortlessly with very little background noise. Enjoy powerful quiet kitchen ventilation.

The Pixie Air incorporates CAT (CFM Adjustment Technology) that makes it efficient for Local CFM zoning laws. The Pixie Air keeps your family safe with FOTILE's Intelligent Air Management System that detects harmful organic gases and vents them out of the house. The Pixie Air is a perfect balance of Design, Safety, Performance, and Convenience. Enjoy a fresh clean kitchen with the Pixie Air Series.



Features & Benefits



3.0 Captur-Shield Technology

- Covers 30" cooktop with 5 burners, nearly 6 Sq. Ft. of cooking area
- Creates a "Coanda Effect" ensuring ultra-fast powerful ventilation



Dual WhisPower Motors

- Industry Leading Technology
- Equivalent to 850CFM, powerful and efficient ventilation
- Refreshes the whole kitchen in just minutes



Intelligent Air Management System

- Monitors the Kitchen for harmful gases or noxious fumes
- The fan will automatically operate and extract harmful gases out of the house



Innovative LED Design

- Lights up your cooktop surface so you can easily see the food you are cooking
- Bright Vision with avg. 600LUX



Simple to Clean

- Detachable Captur-Shields with integrated oil cup
- Dishwasher safe or hand clean with soap and water



Motion Gesture Activation

- Contact-less Touch Free Operation
- Simply Wave to the Pixie Air, and it will automatically Power On / Off with fan and lights

Actual color may vary. Design, specifications and color availability are subject to change without notice. Non-metric weights and measurements are approximate. ©2020 FOTILE America LLC.

6 Campus Dr, Suite 210, Parsippany, NJ 07054 Tel: 1(888)315-0366 Web: fotileglobal.com

FOTILE is a registered trademark of FOTILE Group

Pixie Air™ Series

WHISPER POWER

30" UNDER-CABINET RANGE HOOD (Convertible)

Models: **UQS3001**, **UQG3002**

FOTILE

A BREATH OF FRESH ENGINEERING®



| MODEL | UQS3001 | UQG3002 |
|---|--|--|
| Dimensions & Weight | | |
| Product Size (WxHxD)(inch) | 29 13/16 x 8 5/16 x 22 1/16 | 29 13/16 x 8 5/16 x 22 1/16 |
| Duct Size (inch) | Vertical: Round 7" Horizontal: Rectangular 3 1/4" x 10" | Vertical: Round 7" Horizontal: Rectangular 3 1/4" x 10" |
| REC. Mounting Height (from cooktop to the bottom of cabinet) | 32"-36" | 32"-36" |
| Net Weight (lb) | 52 | 52 |
| Gross Weight (lb) | 62 | 62 |
| Packing-Box Size (WxDxH)(inch) | 34 1/2 x 15 3/4 x 28 3/4 | 34 1/2 x 15 3/4 x 28 3/4 |
| Technical Specifications | | |
| Motor | Dual AC Motors | Dual AC Motors |
| Motor Power (W) | 256W | 260W |
| Power Supply | 120V/60Hz | 120V/60Hz |
| Amps | Max. 1.7A | Max. 2.3A |
| Power Plug | Included | Included |
| Features and Functions | | |
| Material | Stainless Steel | Stainless Steel with Tempered-glass Panel |
| Max Static Pressure (Pa) | 340Pa | 410Pa |
| Speed Setting | 3 | 4 |
| CFM (HVI) - Horizontal | 250 / 380 / 490 | 250 / 380 / 480 / 610 |
| CFM (HVI) - Vertical | 250 / 380 / 480 | 250 / 380 / 490 / 630 |
| Max. EQUIV.CFM | 800CFM* | 850CFM* |
| Noise Level (dB) - Horizontal | 38.26 / 45.95 / 51.08 | 38.20 / 46.01 / 51.25 / 56.10 |
| Noise Level (dB) - Vertical | 38.67 / 47.32 / 52.12 | 38.50 / 46.93 / 51.92 / 57.89 |
| Noise Level (sones) - Horizontal | 1.7 / 4.1 / 5.0 | 1.2 / 3.6 / 5.0 / 7.4 |
| Noise Level (sones) - Vertical | 0.9 / 2.2 / 3.6 | 1.0 / 2.2 / 3.6 / 5.5 |
| Illumination (W) | 3W x 2 (LED)(5500°K)(avg.600LUX) | 3W x 2 (LED)(5500°K)(avg.600LUX) |
| Night Mode Lighting | N | Y |
| Oil Cup | One-piece (Dishwasher Safe) | One-piece (Dishwasher Safe) |
| Oil Filter | Simple to Clean | Simple to Clean |
| Captur-Shield | Professional 3.0 Gen | Professional 3.0 Gen |
| Control Type | Soft Touch Buttons | Micro Touch Control & Motion Activation |
| Delay Shutoff | N | 5 / 15 / 30min |
| Boost | N | Y |
| CAT (CFM Adjustment Tech) | Y** | Y** |
| Intelligent Air Management | Y | Y |
| Oil Filtration Rate | 94% | 94% |
| Odor Reduction Rate | 99% | 99% |
| Accessories | Recirculation Kit (Optional) | Recirculation Kit (Optional) |
| Warranty | | |
| 5 YEARS PARTS (LIFETIME MOTORS) ; 2 YEARS LABOR | | |

*FOTILE Equivalent CFM is a higher CFM rating due to our filterless technology that combines WhisPower Motors and Capture-Shield design. By utilizing this technology, FOTILE applies the Coanda Effect by accelerating smoke extraction and grease separation, and increasing our Capture Efficiency. This enables FOTILE to cover a larger cooktop surface (6 Sq Ft) and achieve a 94% oil filtration rate, and 99% odor reduction rate, keeping your kitchen smoke free and smelling fresh.

**The FOTILE CAT (CFM Adjustment Tech) function can not be reversed or DEACTIVATED once it is ACTIVATED. When ACTIVATED the CAT feature will reduce the CFM rating according to your local municipality ordinance.

Pixie Air™ Series

WHISPER POWER

30" UNDER-CABINET RANGE HOOD (Convertible)

Models: UQS3001, UQG3002

Product Dimensions

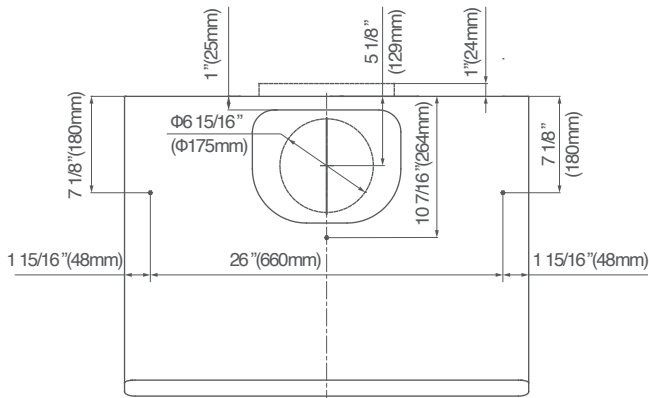

TOP

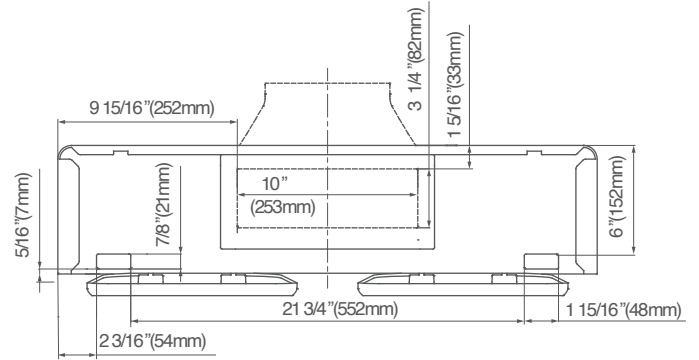

BACK

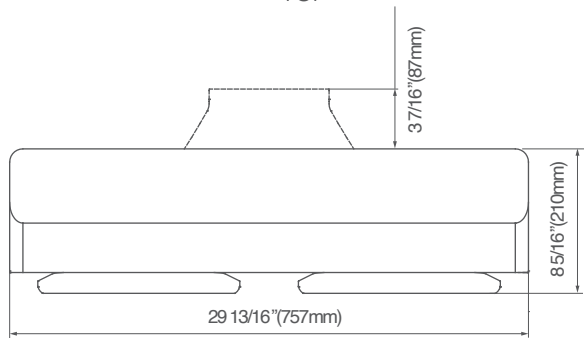

SIDE

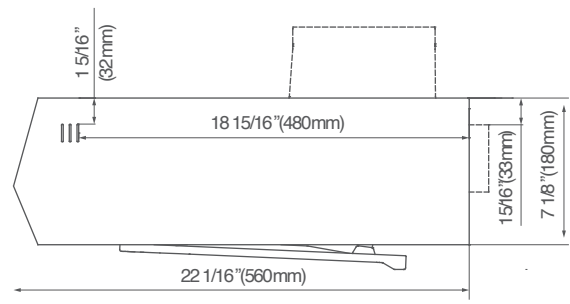

FRONT

Kitchen Design



UQG3002



UQG3002



UQS3001



UQS3001