



# SPECIFICATIONS

## COS-QB48 Range Hood



<b>Size</b>	48 Inch
<b>Mounting Type</b>	Under Cabinet
<b>Controls</b>	Push Button
<b>Filters</b>	3 x Stainless Steel Baffle Filters
<b>Material</b>	430 Grade Stainless Steel
<b>Air Flow</b>	500 CFM
<b>Noise Level</b>	40 dB*
<b>Vent Style</b>	External
<b>Lighting</b>	2 x Front LED
<b>Voltage</b>	120V / 60Hz
<b>Wattage</b>	264W
<b>Included Components</b>	Bulb(s), Damper, Exhaust Vent, Fan Hardware, Installation Kit, Power Cord

### COS-QB48

Presenting this professional style range hood, Cosmo's COS-QB48 Range Hood is powered by 500 CFM of suction, LED lights and ARC-FLOW® Stainless Steel Permanent Filters.



3 Fan Speeds



Push Button Controls



LED Lighting

### Features

- Designed for under cabinet mounting
- 3 fan speeds
- 500 CFM airflow capacity
- Push button controls
- ARC-FLOW® permanent filters
- Front LED lights
- Noise level as 40 dB\*
- Top vented



See Page 2 for dimensions

For more information, please visit: [www.cosmoappliances.com](http://www.cosmoappliances.com)

\* Noise level as low as 40 dB on lowest fan speed with rigid ducting (sold separately) under optimal conditions



# DIMENSIONS

**COS-QB48** Range Hood

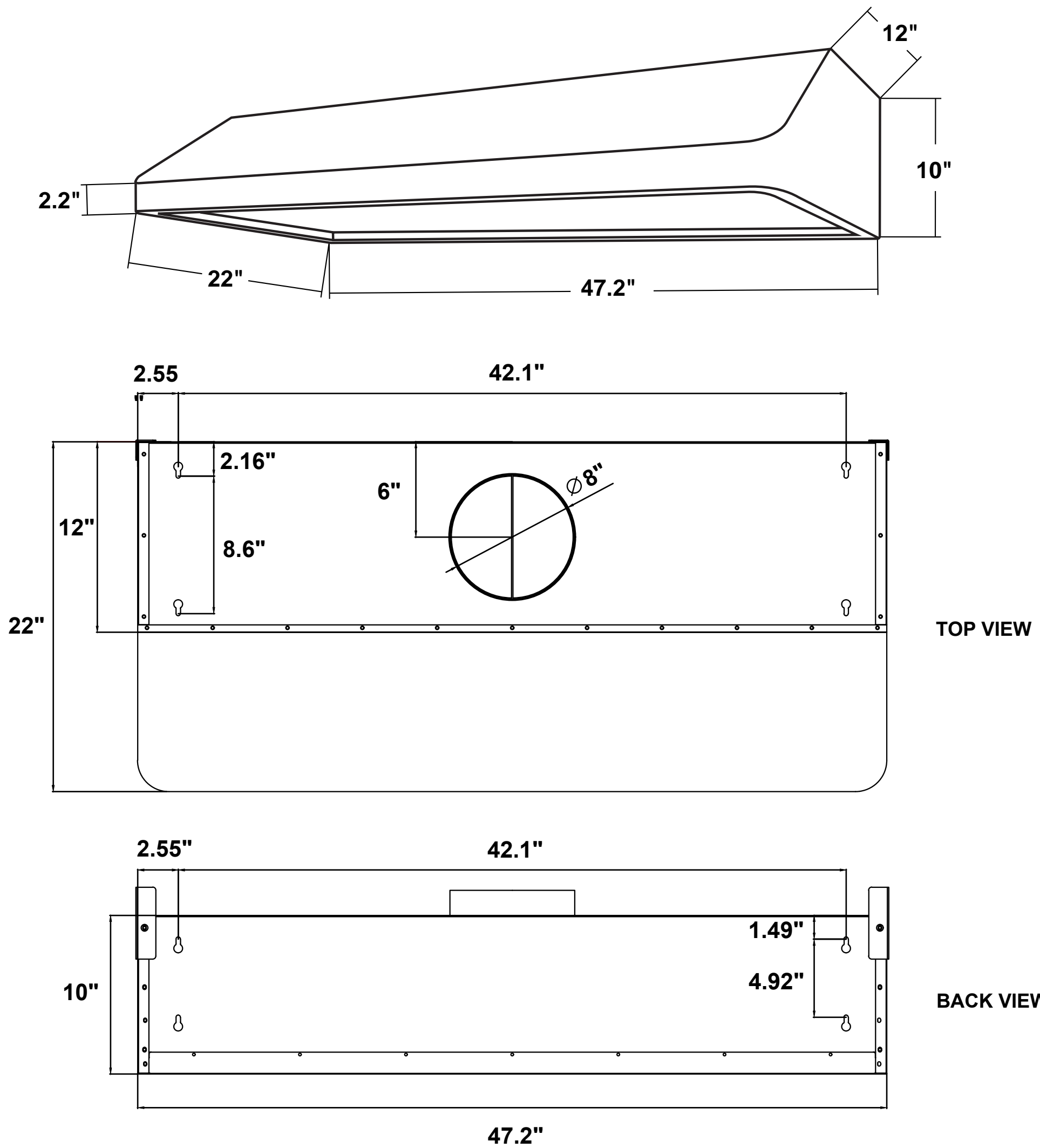

**Dimensions (WxDxH): 47.2" x 22" x 10"**