

MIGHTY TRANSPORT CART

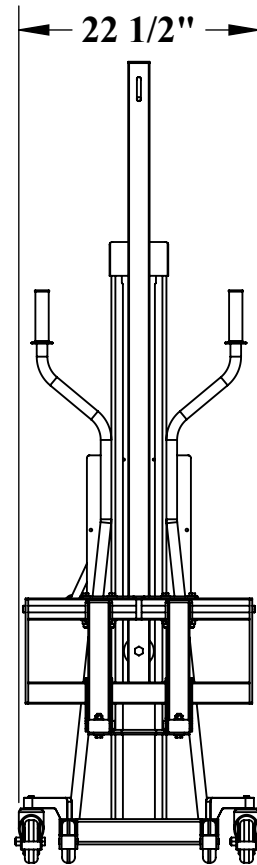
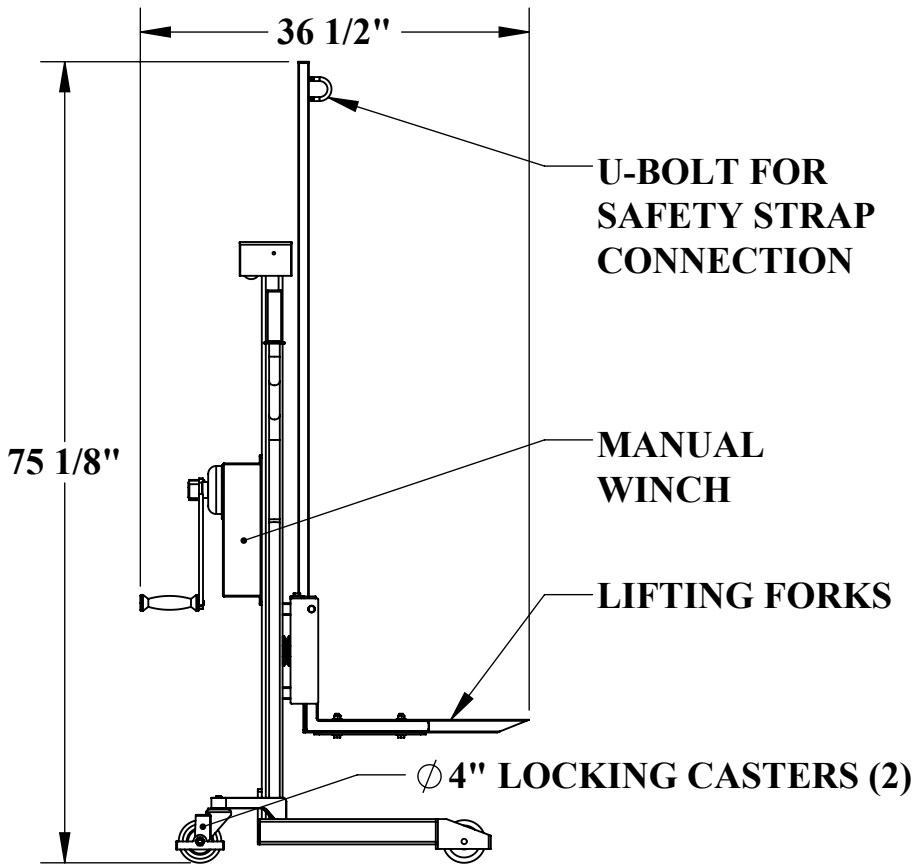

SPECIFICATIONS:

THE AQUA CREEK MIGHTY TRANSPORT CART SHALL BE A MANUAL WINCH POWERED TRANSPORT CART WITH CAPTURE BARS DESIGNED TO BE USED IN THE SAFE REMOVAL AND TRANSPORT OF THE MIGHTY LIFT. THE CART SHALL BE EASILY OPERABLE BY ONE PERSON, AND SHALL HOLD THE MIGHTY LIFT SECURELY AND STEADILY FOR TRANSPORT AND STORAGE. IT SHALL BE CONSTRUCTED PRIMARILY OF POWDER COATED STEEL AND STAINLESS STEEL, AND SHALL INCLUDE 4" LOCKING CASTERS.

MAIN ASSEMBLY:	POWDER COATED CARBON STEEL
MAST FORK ASSEMBLY:	POWDER COATED 304L STAINLESS STEEL
CASTERS:	4" LOCKING POLYOLEFIN
FRONT WHEELS:	3.5" POLYETHYLENE
WARRANTY:	1 YEAR LIMITED

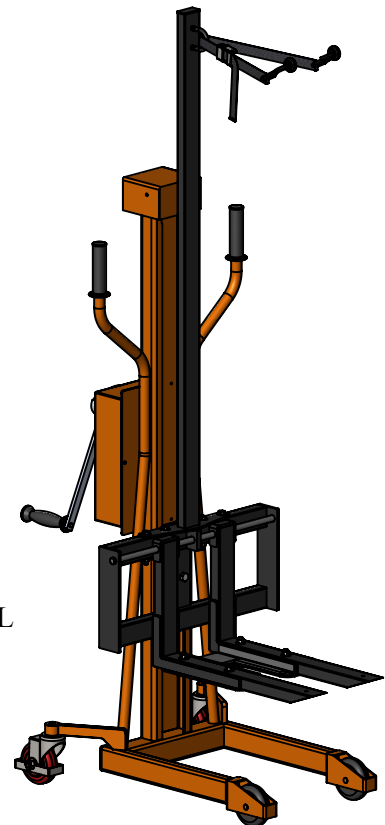

9889 GARRYMORE LANE
 MISSOULA, MT 59808
 (406) 549-0769
 FAX (406) 549-2602

NOTE:
 *SPECIFICATIONS ARE SUBJECT TO CHANGE WITHOUT NOTICE

PRODUCT:		TRANSPORT CART	
PART #:		F-MTTC	
SCALE:	1:18	DATE:	11/25/2019
DRAWN BY:	KR	REVISION:	A