

ZAPPY³

PRO-FLEX



US Patent D540, 400
Other Patents Pending

Read this manual
completely before
assembling and riding
our ZAPPY3 PRO-FLEX



Always wear a Helmet!

Owner's Manual

ZAP

501 Fourth Street Santa Rosa, CA 95401/USA

Tel(707)525 8658/fax(707)525 8692

zap@zapworld.com Stock Symbol:ZAAP

WWW.ZAPWORLD.COM

@ZAP 2011 All Rights Reserved



Table of Contents

Technical Information-----	1
Warning Statement-----	2
Read Before Riding-----	3
List Of Parts-----	4
Front Bar-----	6
Tool Kits In The Tool Bag-----	7
Assembling The Zappy ³ -----	8
Charging The Batteries-----	12
Riding The Zappy ³ -----	13
Folding The Zappy ³ -----	15
Maintenance-----	17
Wiring Diagram-----	18
Trouble Shooting Guide-----	20
Warranty-----	22

Model No.	ZAPPY ³ PRO-FLEX
Product size	40 L x 27 W x 38 H inch (102 L x 68 W x 98 H cm)
Type of motor	Permanent-magnet brushless DC wheel motor
Motor power	Wheel motor 36 V 350 W / 48V 500W
Battery type	sealed lead acid battery
Battery capacity	36 Volt 12Ah / 48V 12Ah
Charger	110V-240V, UL approved
Charging time	4-6 hours
Max. speed	Up to 13 MPH (22 km/h) 15 MPH (25km/h)
Single charge	Up to 17 MILES (28 km) 20 MILES (32km)
Max capacity	220 LBS (100 kg)
Net weight	101 LBS (46 kg) 112LBS (51kg)



IMPORTANT!

Before you operate your ZAPPY³ please read carefully:

YOUR EXISTING INSURANCE POLICY MAY NOT PROVIDE COVERAGE FOR ELECTRIC VEHICLES, YOU SHOULD CONTACT YOUR INSURANCE AGENT TO DETERMINE IF COVERAGE IS PROVIDED.



Do not ride this scooter until you read and thoroughly understand the owner's manual. It contains information critical to your safety. If you have questions about the operation of this scooter, you should consult your authorized dealer.



It is extremely important that you follow the safety guidelines contained in this manual in order to insure maximum safety.



Failure to comply with the standards outlined in this manual could result in fire and/or serious injury.



ZAP is not liable for any damage or injuries caused by unsafe or faulty repairs. Any repairs made to this product by unauthorized service technicians are the sole responsibility of the owner.



Our products are designed to be ecologically conscious, please dispose of used batteries in compliance with local laws.

WARNING

THE ELECTRIC ZAPPY3 IS NOT A TOY AND SHOULD NOT BE OPERATED BY ANY ONE UNDER 12 YEARS OLD.

Safety Instruction

(Please take note of the followings before each ride)

- The maximum weight capacity is 220 LBS.
- Only one person at a time should ride.
- Always wear protective gear including knee and elbow pads and an approved safety helmet when riding the ZAPPY3.
- Before riding be sure to check that all pivot points, locking buttons, quick releases, and latches are secured properly.
- The power switch lock must be in the “off” position when the ZAPPY3 is being charged.
- Do not use the ZAPPY3 when it is raining.
- Do not place the battery near heat or fire.
- Do not expose the charger to water or any moisture.
- Check if battery is properly charged and installed.
- Charge battery after each use.
- Always ride on dry paved surfaces. Gravel, wet and uneven surfaces are a hazard.

Check if all tires are properly inflated.

List Of Parts

ZAPPY³
PRO-FLEX



- 1 Throttle
- 2 Multi-function Instrument
- 3 Brake lever
- 4 Alloy handlebar tub
- 5 Quick release
- 6 Connecting tube
- 7 Seat
- 8 Battery & controller compartment
- 9 Balancing wheel
- 10 Footboard
- 11 Rear wheel
- 12 Power connecting plugs
- 13 Allen set screw
- 14 Front fender
- 15 Front fork
- 16 Motor
- 17 Front wheel
- 18 Basket
- 19 Charger port

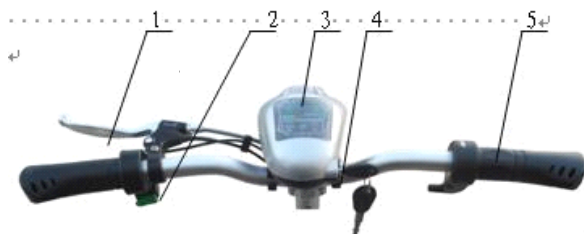

- 1 Brake lever
- 2 Horn switch
- 3 Multi-function Instrument
- 4 Key switch
- 5 Throttle



- 1 Screwdriver
- 2 Allen wrench (2.5mm)
- 3 Allen wrench (3mm)
- 4 Allen wrench (5mm)
- 5 Allen wrench (6mm)
- 6 Wrench (8 x 10mm)
- 7 Wrench (16 x 18mm)
- 8 Wrench (16 x 18mm)
- 9 charger

1. Unpack the ZAPPY³ carefully so that you do not misplace any of the parts.



2. Place the ZAPPY³ on a flat, level surface. Block the front up 3.5". This will make the next step easier

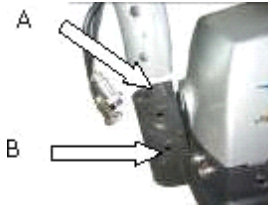

3. Remove the bolts and nuts from the connecting tube clamp (B). Place the connecting tube into the top opening (A). After aligning the holes, place the two bolts through the connecting tube and neck assembly. Twist the bolts, do not hammer them through. Tighten these two bolts with the nuts provided.



4. The two Allen set screws on the front of the connecting clamp are for removing any play after the bolts have been tightened. First, back off the nuts, second, set the screws, third, tighten the nuts to prevent the screws from backing off.

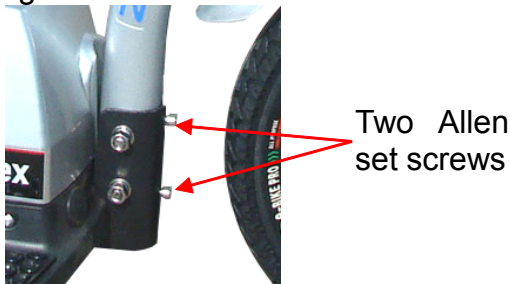

5. Extend the handle bar tube to full upright position, and slide it into connecting with the front fork.

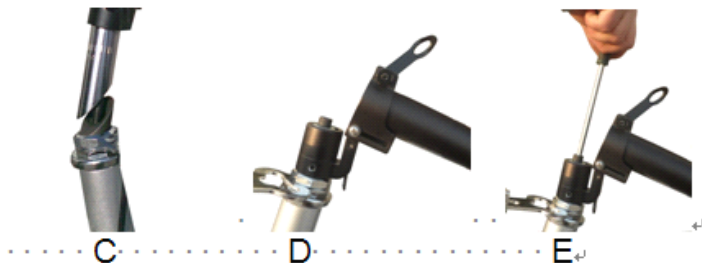

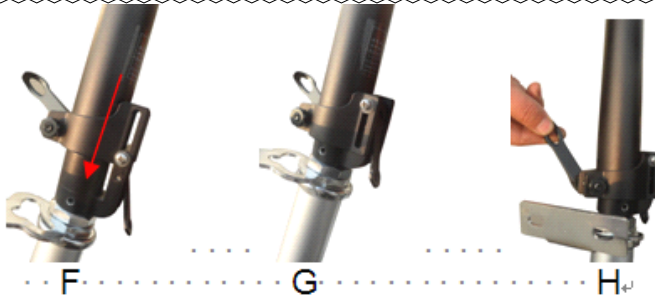

7. Ensure that the handlebar is facing front, the brake on the left side and the throttle on the right, then tighten the handlebar tube collar clamp using the enclosed 5mm wrench
8. Plug in the two power connecting plugs into the sockets. The design of each plug and socket is different. Connect the ones which best fit each other to finish the assembly.



9. Match the pins of the plugs to the holes of the sockets. Note the alignment notches.

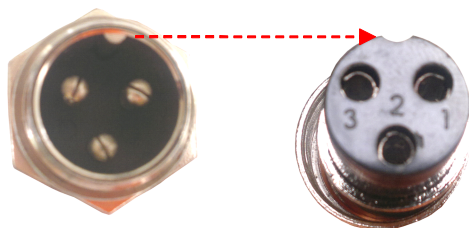

NOTE: Handle bar height adjustment. Handle bar height can be easily adjusted by opening the quick release on the handlebar tube to preferred height, then firmly closing quick release.

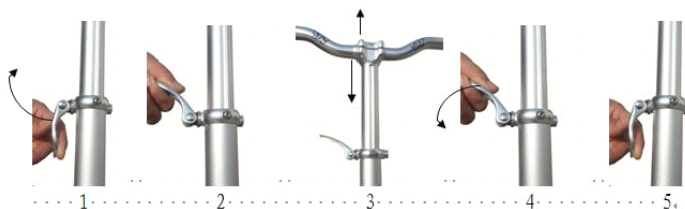

Charging The Batteries

ZAPPY³
PRO-FLEX

- Before you ride the ZAPPY³ for the first time you must charge the batteries for 4-6 hours using only the supplied charger.
- To charge the batteries, plug the charger into the charger socket located on the rear side of the battery/ controller compartment. Then plug the charger into a wall outlet.

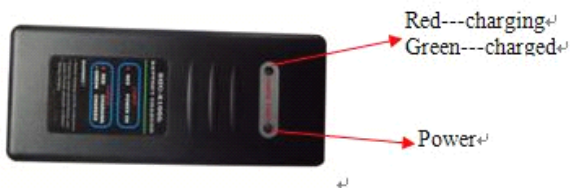
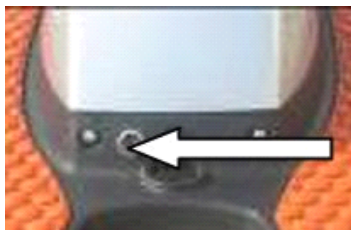

● Once you have completed the initial charge you are ready to ride. Remember, this is not a toy. The ZAPPY³ can reach speeds up to 13 mph / 15 mph depending on the terrain and the weight of the rider. You must wear a helmet and protective pads. Be aware of all local laws and ordinances that govern and/or restrict the use of powered scooters. The laws and ordinances vary greatly from municipality to municipality. It is your responsibility to know and abide by your local restrictions.

● To ride, plug the key into the key switch and turn the key in clockwise direction till the first click. The battery gauge will be illuminated indicating that the battery is in operation. If you want to turn on the front light, please turn the key to the second click in clockwise direction.



● Hold onto the front bar with both hands. Your left fingers will control the brakes and your right

hand will control the throttle. As you turn the throttle towards yourself, the speed will be increased. Release the throttle and apply the brake to stop the scooter. You will control the speed of the scooter by using both the throttle and the brake. When the brake handle is squeezed it cuts power off the throttle.

NOTE 1: WARNING: Never try stunts . Always maintain a safe speed.

NOTE 2: When scooter is parked, please turn off the power and take off the key, this will avoid anyone from accidentally turning the throttle causing the scooter to speed forward. Failure to do this could lead to an accident.

NOTE 3: If you need to stop in an emergency or kill power quickly, you can turn the key off.

1. Turn off the key switch
2. Press the quick release to bottom.



3. Lift the clip bar, at the same time pull the handlebar tube.



4. Lift the connecting tube (which is also attached to the handlebar tube).



5. Carefully place the handlebar tube on the footrest frame



Battery: (for professional use only)

The ZAPPY³ Pro-Flex is powered by **three/four** 12 volt, rechargeable batteries housed in a single compartment. Other than recharging, these batteries need no maintenance. To prolong battery life, recharge the battery after each use. You must also charge your ZAPPY³ Pro-Flex if it has not been used for 30 days or more. If you need to replace the battery pack, it is located inside the battery compartment on the footboard. To get to the battery pack, remove the compartment cover by loosening the screws. To remove the batteries disconnect the wires from the battery terminals. Replace the battery pack with a new one and reconnect the wires. Follow the instructions on charging batteries to charge the new batteries.

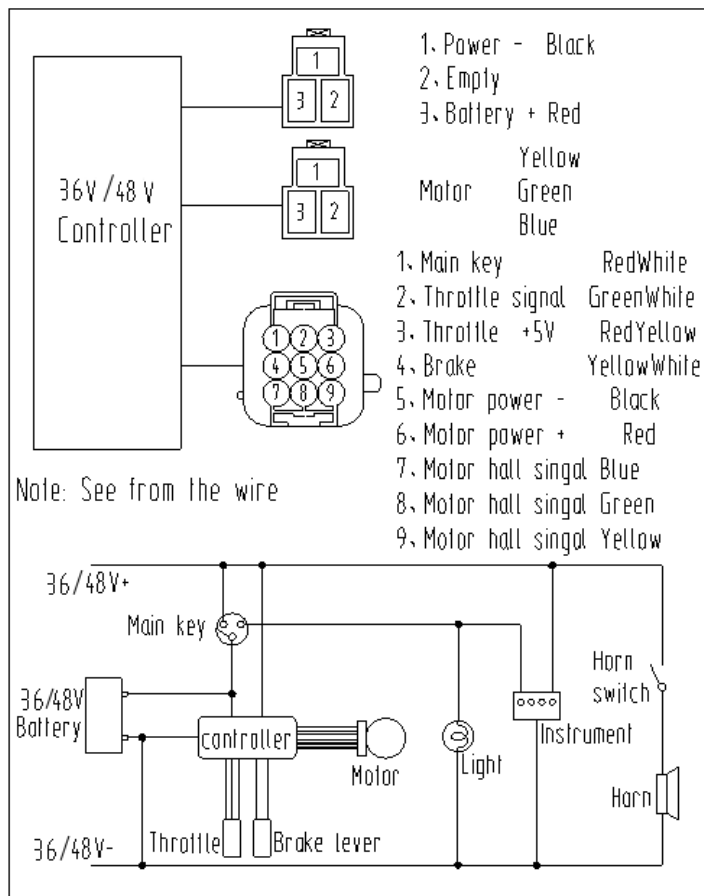

Wiring Diagram

ZAPPY³
PRO-FLEX

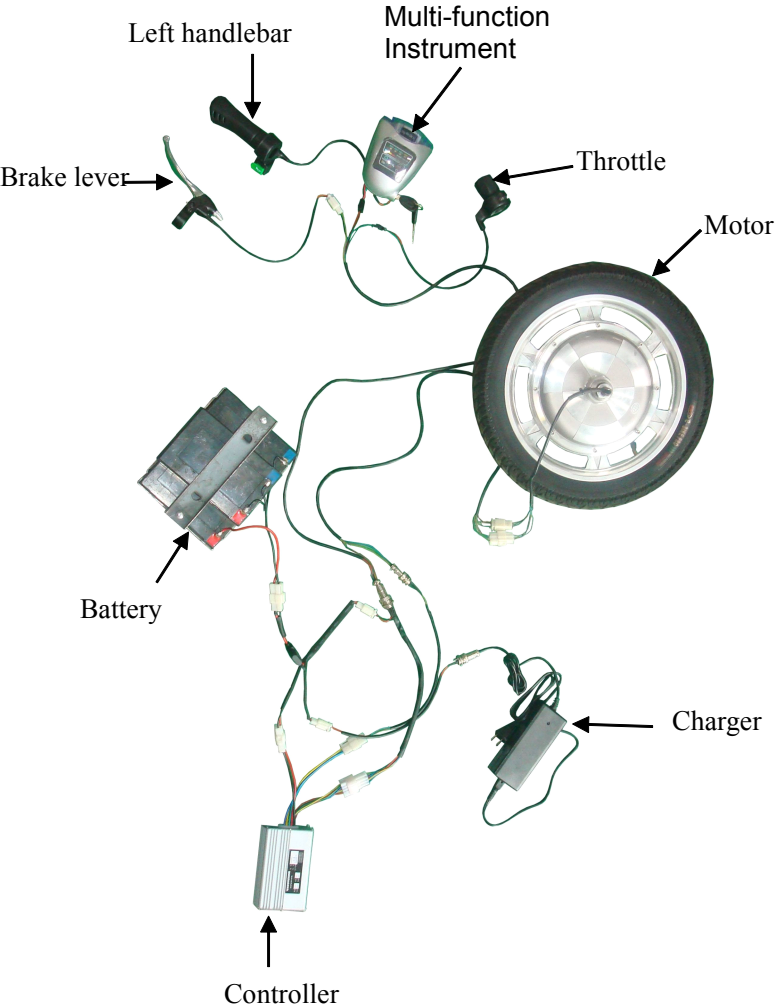

Problem	Cause	Solution
The power light on the instrument does not illuminate when the ZAPPY ³ Pro-Flex is on.	<ol style="list-style-type: none">1. Battery is discharged.2. Loose connection inside the ZAPPY³ Pro-Flex.3. Fuse is blown.4. The instrument is defective	<ol style="list-style-type: none">1. Recharge your ZAPPY³ Pro-Flex.2. Remove the screws that hold the battery compartment cover and raise the cover. Visually inspect all wire connections making sure there are no loose wires, reconnecting those that are.3. Replace the fuse.4. Replace the instrument.
The power indicator on the instrument illuminates but ZAPPY ³ Pro-Flex still does not work.	<ol style="list-style-type: none">1. The throttle handle is not operating properly.	<ol style="list-style-type: none">1. Replace the throttle handle. Call Customer Service to order a new throttle

Trouble Shooting Guide

ZAPPY³
PRO-FLEX

Noise coming from motor	1 The motor sensor is defective.	1. Call Customer Service to change a new sensor
When the brake lever is squeezed the ZAPPY ³ Pro-Flex does not stop.	1. The brakes are not adjusted properly.	1. Adjust the brake by loosening the bolt on the rear brake wheel, pull the cable and retighten the bolt.
Scooter is losing speed.	1. Low battery 2. Battery is defective	1. Recharge your battery for 4~6 hours. 2. Replace battery. Call Customer Service to order a new battery.

The Limited Warranty does not cover or apply to the following: Normal wear and tear; any damage, failure and/or loss caused by accident, misuse, neglect, abuse and/or failure to follow instructions or warnings as stated on the product or in the applicable owner's manual or other printed materials provided with the product; damage, failure and/or loss caused by the use of the product in any other manner for which such products were not specifically designed.

ZAP warrants each new ZAP product for six (6) months according to the following terms. Batteries and tires are warranted for three (3) months. This warranty extends to the original retail purchaser only and commences on the date of the original retail purchase. Any part of the ZAP product manufactured or supplied by ZAP and found in the reasonable judgment of ZAP to be defective in material or workmanship will be repaired or replaced by an authorized ZAP service dealer without charge for parts or labor. ZAP is responsible for the expense of delivering the warranty replacement parts. However, if the customer chooses not to replace the parts, the expense of delivering the ZAP product to the factory or authorized service dealer for warranty

work or the expense of returning it back to the owner after repair or replacement will be paid for by the owner. ZAP's responsibility in respect to claims is limited to making the required repairs or replacements and no claim of breach of warranty shall be cause for cancellation or rescission of the contract of sale of any ZAP product. Proof of date of purchase will be required by the dealer to substantiate any warranty claim. An authorized ZAP service dealer must perform all warranty work. The warranty is limited to thirty (30) days from the date of purchase for any ZAP product that is used for rental demonstration or commercial purposes or any other income producing purpose. This warranty does not cover any ZAP product that has been subject to misuse, neglect, negligence or accident, or has been operated in any way contrary to the operating instructions as specified in the ZAP owner's manual. This warranty does not apply any damage to the ZAP product that is the result of improper maintenance or to any ZAP product that has been altered or modified so as to adversely affect the products operation, performance or durability or that has been altered or modified to change its intended use. This warranty does not extend to repairs made necessary by normal

wear and or by use of parts that are incompatible with ZAP products. In addition this warranty does not cover items that experience normal wear and tear. ZAP reserves the right to improve the design of the product without assuming any obligations to modify any product previously manufactured. All warranties are limited in duration to the six (6) months warranty period. Any such implied warranties including merchantability, fitness for a particular purpose or otherwise are disclaimed in their entirety after the expiration of the appropriate thirty day warranty period. ZAP's obligation under this warranty is strictly and exclusively limited to the repair and replacement of defective parts and ZAP does not assume any other obligation. Some states do not allow limitations on how long an implied warranty lasts, so the above limitation may not apply to you. ZAP assumes no responsibility for incidental consequential or other damages including but not limited to expense of returning the ZAP product to an authorized service dealer and expense of delivering it back to the owner. Mechanic's travel, time telephone charges, rental of a like product during the time the warranty service is being performed travel loss or damage to personal property, loss of revenue, loss of time, or

inconvenience. Some states do not allow the exclusion or limitation of incidental or consequential damages so the above limitations may not apply to you.

WHAT ZAP WILL DO:

ZAP will, at its sole option, either repair, replace or refund the purchase price of any unit that does not conform to this limited warranty. ZAP may choose at its option to use functionally equivalent reconditioned, refurbished or new units or parts or any units. You are responsible to get the unit back to ZAP.

HOW TO GET WARRANTY SERVICE:

To obtain warranty service, please call or fax to the following telephone numbers for ZAP Customer Service - warranty repair

Tel. [1-707-526-6444](tel:1-707-526-6444) or Fax. [1-707-636-0177](tel:1-707-636-0177),
Email: customer-support@zapworld.com

If you purchased from Camping World sales network, please contact Camping World stores.

DO NOT RETURN YOUR PRODUCT TO ANY ADDRESS.

Please call or write for the location of the ZAP authorized service center nearest you and for the procedures for obtaining warranty claims.