



**TRIVEL**

USER MANUAL

AZTECA

## WELCOME WORD

Congratulations on your purchase! We are confident that you will enjoy riding your new Trivel tricycle as we spent a great deal of time designing it with you in mind!

This manual will get you through the necessary information about safety, usage, and maintenance of your new tricycle so you can experience the most of it, for many years.

Please read this manual thoroughly before you go for your first ride and keep in handy for future reference.

If some instructions remain unclear to you, please do not hesitate to contact us or your dealer for further explanation.

## ABOUT US

For over 25 years, the passionate, dedicated Trivel team has been designing and manufacturing tricycles for reduced mobility children and adults, thus providing them with hours of fun and pleasure. We can install a wide range of custom components onto your tricycle, so it is fully adapted to the user's specific needs.

To learn more about our products, parts, accessories and services, please visit [www.trivel.com](http://www.trivel.com)

## TABLE OF CONTENTS

Welcome word .....	2	Riding with feet securing devices .....	24	<b>Maintenance and adjustments.....</b>	<b>48</b>
About us .....	2	<b>Using the Power assistance system.....</b>	<b>25</b>	Tools, products and protective gear needed.....	49
Table of Contents .....	3	Safety warnings .....	25	Preventive maintenance.....	50
A word on safety .....	4	Notice to the user .....	26	Tire pressure adjustment .....	50
Before your first ride .....	7	Description of the components.....	29	Changing a punctured inner tube.....	52
Before each ride .....	7	Getting started.....	32	Brake adjustments.....	54
Setting your position on your Trivel .....	9	Using the LCD Panel functions .....	35	Derailluers adjustments.....	59
Setting the seat position and angle.....	10	Turning the power assist system on .....	38	Quick release binder system adjustment .....	64
Setting the backrest height and angle.....	12	Choosing an assistance mode.....	38	Folding the stem .....	67
Setting the handlebar position .....	13	Operating range and battery usage optimisation.....	41	Lubricating the chain.....	68
<b>Riding basics .....</b>	<b>14</b>	Removing or inserting the battery.....	42	Washing your Trivel.....	69
Turning.....	15	Charging the battery of your electric		Storing your Trivel.....	70
Going uphill.....	16	power assist system.....	44	Normal wear.....	71
Braking.....	17	Storing the battery.....	45	<b>Troubleshooting.....</b>	<b>72</b>
Using gears.....	17	Minimum battery maintenance schedule.....	46	<b>Warranty terms.....</b>	<b>76</b>
Riding in wet condition.....	23	Troubleshooting (Electric assistance system).....	47		
Riding at night.....	24	Error codes .....	47		

## A WORD ON SAFETY

Trivel puts a great effort in developing the safest product possible. Riding a tricycle, like most other sporting activities, involves some risks. People who engage in this activity must be aware of those risks and fully assume them.

A Trivel is a very safe and stable vehicle thanks to its three-wheel triangular platform design. Although it is propelled in a similar way than a regular two-wheel bicycle, its handling characteristics are significantly different. Make sure to read and understand the [Riding Basics](#) section of this manual to learn about important advices on how to operate such a vehicle before your first ride.

Most of the accidents are caused by human factors such as bad judgment of a hazardous situation, improper handling or neglecting the equipment's mechanical maintenance.

Many serious injuries can be prevented only by wearing adequate protective equipment such as a homologated helmet.

Respecting the local road laws and getting to know how to properly use and maintain your tricycle with the help of this manual will also help significantly to reduce the risks of injuries.

It is the rider's responsibility to fully understand the usage of the equipment he or she is operating.

In the case of a child operating the tricycle, it is the responsible adult's duty to educate on local public road laws, supervise safe riding activity and ensure the proper fit, adjustment and good mechanical condition of the equipment.

The following signs will be used throughout the manual. They represent Warnings and Cautions about important

or hazardous situations that must be fully understood to avoid damage to your equipment, personal injuries or even death.



*This sign indicates a serious warning about a potential risk of injury or death or other safety information*



*This sign indicates cautions about the proper use of the equipment or other important information*



*For everything related to the use, maintenance and storage of a Power assisted system, please refer to the section [Power assistance system instructions](#)*



*Check all component connections and accessories attachment before every ride. Do not ride your tricycle with loose components or accessories. Take the tricycle to your dealer if necessary.*



*Always wear a homologated helmet, it could save your life. Make sure it is properly attached and positioned on your head.*



*Always place user's feet safely on pedals. Use adequate pedal attachment system if needed.*



*If using a backrest, harness or any other support system, make sure to properly tighten the belts and straps on user.*



*Make sure the user's toes are not allowed to touch the ground at any time.*



*Choose bright, visible clothing. Preferably closely fitted to your body to avoid entanglement into components. Lace shoes properly.*



*Trivel is not responsible for accidents caused by the use or handling when tricycle is towed by an adult's regular bike, or by its capsizing when the child gets off his or her tricycle or when he or she activates the brakes.*



*When riding on public roads, always ensure you are visible to other road users. Make sure your tricycle has all the reflectors or lights that are required by the local laws. A safety pennant flag is also recommended for extra visibility.*



*Never ride under the influence of alcohol or illicit substances. This could seriously impair your*

*judgment, reflexes or balance and may lead to prosecutions, serious injuries or even death.*



*Never carry a second passenger on your tricycle unless that is with an approved accessory equipment.*



*Do not carry anything on the handlebars or between your legs as this could seriously impact your balance or get caught in the wheels and may cause serious injury or death. Use the provided cargo compartment is your tricycle is equipped with such.*





*Make sure your tricycle is properly fitted to you and that you are fully able to control it.*





*Adapt your riding style and behaviour to each type of terrain, situation, and weather condition.*

 This product and its components were not designed to be used for extreme conditions or stunts. Do not engage in aggressive riding or jumps.

 Do not use for downhill.

 Trivel is not responsible for accidents caused by the use of towing equipment.

 Avoid riding on wet or icy ground if possible. Wet and icy ground seriously reduces traction between tires and road surface. If you must, take extra caution as the risk of slipping and falling is much higher especially when turning and braking.

 Avoid riding at night if possible. Your vision is seriously reduced in the dark and you may not see

obstacles coming at you in time to avoid them. Other road vehicles might also not be able to see you and this can cause very dangerous situations potentially leading to serious injuries or even death.

 When riding with children, always keep a close eye on them and try to stay away from potential hazardous situations such as stairs, steep descents, curbs, traffic, etc. Show a good example by following all safety recommendations.

 Avoid direct contact with sea water and your equipment. Wipe off any sea spray particles or sand whenever possible. Calcium can quickly damage important component of your tricycle.

 Always lock your tricycle to an immovable object with a high-quality bicycle lock when left

unattended. It is also recommended to lock any component with a quick release attachment device.

 Take note of your product serial number and store it somewhere secured. This unique identification number can be required by Trivel customer service for warranty purpose. It can also help proving your ownership of the equipment to your insurance company or local police service in case it is stolen.

 This product may contain chemicals known to the state of California to cause cancer and birth defects or other reproductive harm, including paint, lubricants, and various metals. Wash hands thoroughly after handling this product. (California Prop 65).

## BEFORE YOUR FIRST RIDE

Congratulations, you are about to experience a great feeling; riding a Trivel! To ensure you have a pleasant first ride, please make sure to follow these simple instructions:

1. Read or have someone read to you this manual's [Safety Warnings](#) and [Riding Basics](#) sections. Only until these sections have been fully understood is it recommended to go for your first ride.
2. Adjust the seat, backrest, and handlebars to the recommended position for you. See [Adjusting your Trivel](#) section to learn how.
3. Proceed to a safety check on the equipment. See [Equipment Safety check](#) on the following chapter.
4. You're good to go! Put your helmet on and enjoy the ride!



*It is strongly recommended that you choose a private or closed-circuit road without major inclines or heavy vehicles get to know how your Trivel handles and how control components such as the brakes and derailleurs feel.*

## BEFORE EACH RIDE

### EQUIPMENT SAFETY CHECK

Proceed to the following Equipment safety check before going for a ride.

#### 1. Check components attachment

- a. Check front wheel attachment by lifting the front end of your Trivel and firmly hitting down on the top of the wheel. There should be no movement of the wheel. Tighten the nuts or quick-release binding system if the wheel moves or gets off the fork. [See the quick-release binder adjustment section for instructions.](#)
- b. Check handlebars, seat, backrest and all other attachment systems for unwanted movement. Tighten loose components if needed.

[See the Setting your position on your Trivel section for instructions.](#)

## 2. Check brakes function

- a. Pull the brake levers with full strength and make sure the brakes are stopping the wheels from spinning efficiently.
- b. Brake pads should reach the rim around the first third of the brake lever stroke.
- c. The brake lever should not get in contact with the grip.
- d. The wheel should be able to spin freely when the brake lever is released.

If these conditions are not met, an adjustment of your brakes is required. [See brake adjustment section for instructions.](#)

## 3. Check tire pressure

- a. Use a pressure gage or connect a pump with a pressure gage to each tire's valve to get a pressure reading. Make sure the pressure is within the tire's recommended pressure value.

This information is engraved on each tire's sidewall. Adjust pressure with a pump if it is below the recommended minimum pressure. It is normal for a tire to lose a bit of its air pressure after a while. However, if your tire is completely flat (out of air pressure), it is likely that its inner tube has been punctured. You will need to repair or replace the inner tube before you can go for a ride. [See tire pressure adjustment and puncture repair section for instructions.](#)

## 4. Check the chain's lubrication

- a. Spin the chainwheel backwards and visually inspect the chain for proper lubrication. A squeaking sound when the chainwheel is spinning is also an easy symptom to spot that tells you that your chain needs to be lubricated. In doubt, add some lubricant. [See the Lubricating the chain section for instructions.](#)

 *If possible, always ride with someone else. This way, in the case of an accident, one can call for assistance and wait along with the injured rider.*

 *If you are going by yourself, tell someone you know about your itinerary and expected return time. Bring a cellular phone if possible.*

 *If using a power assist system, think about the planned distance of your ride and battery autonomy. Adapt your power assist level accordingly. See [Optimizing your battery life](#) section in [Getting Started](#) chapter for more details on how to increase your range.*



## SETTING YOUR POSITION ON YOUR TRIVEL

Comfort is key to a pleasant ride. Your Trivel is offering many ergonomic adjustments to ensure your position is optimal. We recommend the following key points for a proper positioning.

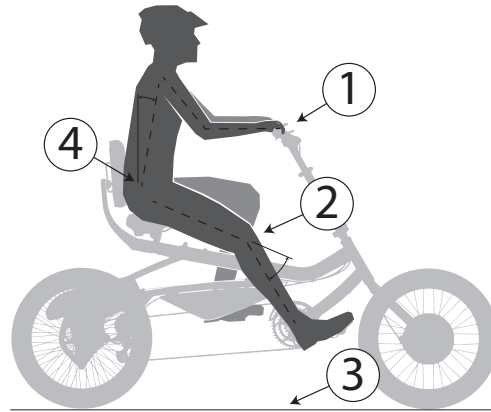

1. Adjust handlebar height so the forearms are parallel to the ground when the user is sitting.
2. Set the seat position so that there is a slight bend of the knee when the pedal is at the farthest point.
3. The user must be able to reach the ground with the foot while sitting in case of emergency.
4. Adjust the saddle and backrest height and angle so that the user's torso angle is close to be vertical (depending on riding style and preference).

## SETTING THE SEAT POSITION AND ANGLE

The seat position is the principal setting that can be adjusted to modify the user's position.

Moving it back or forth will change the torso angle and leg extension when pedalling so an optimal control and pedalling efficiency can be obtained.

For a more active position, we recommend that the seat be adjusted so that the user has a slightly bent forward torso angle as well as an approximate knee angle of 25 degrees when the pedal is at its farthest point when pedalling.

For a more relaxed position, the seat can be moved forward, thus allowing less leg extension and an upright or laid-back torso angle.

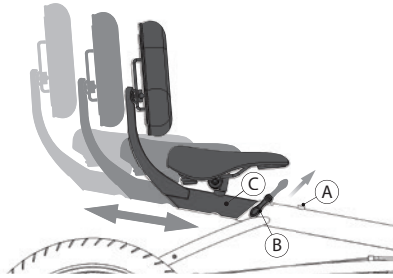

- A. Anti rotation screw
- B. Quick release binder lever
- C. Seat beam

Set seat position by moving the Seat Beam (C) forward or backward along the frame.

1. Loosen the seat beam anti rotation set screw (A) using an Allen key
2. Pull the quick release binder lever (B) to its open position to free the seat beam (C)
3. Adjust seat position to the desired distance from the chainwheel
4. Push the quick release binder lever (B) back to its closed position to lock the seat beam (C) into the new position
5. Tighten the seat beam anti rotation set screw (A) with the Allen key

The seat angle can be adjusted to your personal preference whether you wish for a straight, upright position or a more relaxed, laid back seating position. You should also consider adjusting the backrest height and angle accordingly.

Set the seat angle by rotating the seat (A) upward or downward along the seat carrier clamp (B).

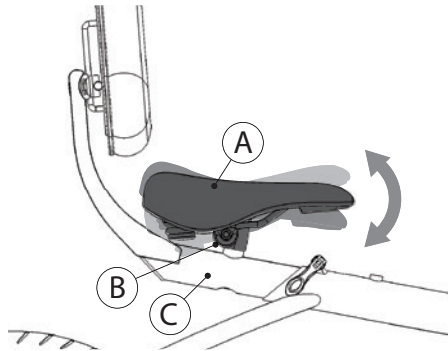

A. Seat

B. Seat carrier clamp

C. Seat beam

1. Loosen the seat carrier clamp (B) using a wrench until the saddle (A) can rotate freely
2. Rotate the saddle (A) upward or downward to the desired angle
3. Re-center the saddle (A) along the seat beam (C) if it is unaligned
4. Tighten the seat carrier clamp (B) using a wrench until the saddle (A) is locked tightly into its new position.

## SETTING THE BACKREST HEIGHT AND ANGLE

The backrest height and angle are adjusted at the same time using just one tool from the back of the backrest.

The backrest height can be adjusted to reach your lower back precisely where it needs the most support. The angle should be adjusted along with the saddle for an upright or a more laid-back position.

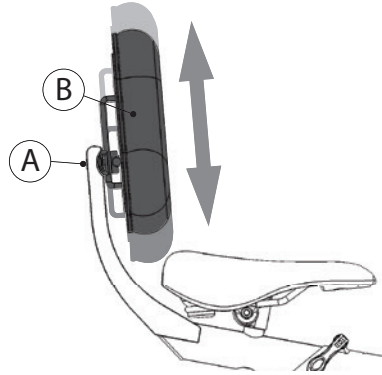

1. Loosen the backrest carrier clamp (A) using an Allen key until the backrest (B) can move freely
2. Move the backrest to the desired height and angle
3. Tighten the backrest in the new position using the Allen key

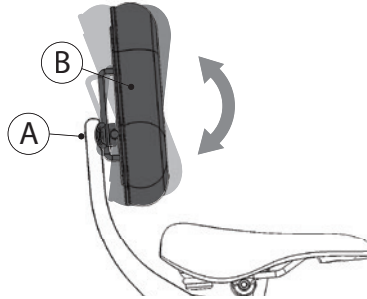

- A. Backrest carrier clamp bolt  
B. Backrest

## SETTING THE HANDLEBAR POSITION



*Make sure to fully understand how to use and adjust a quick release lever before setting the handlebar position. Failure to properly use this mechanism can result into the dismantling of the stem assembly and lead to a loss of control and serious injuries. Instructions on how to use a quick release lever can be found in the [Maintenance and adjustment](#) section.*



*Never lift the stem above the minimum insertion mark engraved on the lower part of the stem. Lifting the stem above this mark can result into the dismantling of the stem assembly and lead to a loss of control and serious injuries.*

You can easily move the stem (B) up or down using only the quick-release lever (A). The stem should be positioned so that the user has his forearms parallel to the ground when he holds the handlebars.

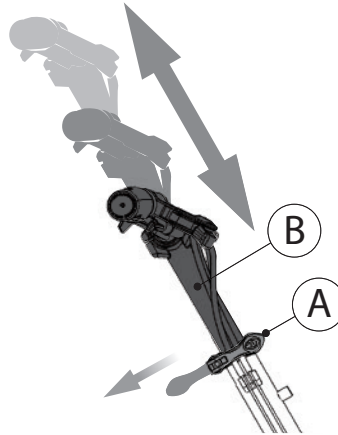

A. Quick release binder lever

B. Stem

1. Pull the quick release binder lever (A) to its open position to free the stem (B)
2. Adjust the stem position to the height required to meet the recommended arm position
3. Check alignment of the handlebars with the front wheel. Realign if not perpendicular.
4. Push the quick release binder lever (A) back to its closed position to lock the stem (B) into the new position

## **RIDING BASICS**

Congratulations on choosing to ride differently! Compared to a regular bicycle, riding a Trivel, with its reclined position offers several benefits.

### **RIDE MORE COMFORTABLY**

A reclined position relieves pressure on your wrists, preventing pain and numbness due to the compression on the hand's nerves. This position also allows for greater support of the lower back, thus helping reduce spine related pain often experienced by riders with less flexibility on a regular bicycle. At last, an upright torso angle virtually eliminates the cervical spine pain due to the stress on the neck that often felt with the traditional bicycle positioning.

### **RIDE MORE EASILY**

A Trivel is an excellent option for people who are new to cycling, those who have a bit less balance or riders who wants to experience a new type of riding. Our distinctive three wheeled platform puts the user in a lower and more centered position along the wheelbase, allowing for fun, easy, free coasting and amazing cornering capabilities.

### **RIDE LONGER**

With less pain you will get higher endurance and will be able to go for longer rides. Breathe more easily with the upright position and enjoy the sceneries with the excellent peripheral view that this position provides.

## TURNING

Practice safe turning first by controlling your speed at all time and especially before going into a curve. It is of the upmost importance that the user gets to know how a Trivel vehicle handles curves at different speeds and on different surfaces. As it was previously recommended in this notice, the user should ride his or her Trivel on a closed-circuit road several times before going on a ride involving the use of public roads.



*A three wheeled vehicle is not able to lean like a two-wheeled vehicle can when turning. You should always allow more time for braking when approaching a curve. Taking a curve at a high speed can lead to a loss of control and braking capacity that can result in serious injuries.*



*If the speed is too high while taking a curve, there is a risk of tipping sideways. It is the responsibility of the user to be in control of his speed and to brake sufficiently before taking a curve. The user must avoid tipping at all time.*



*In a situation where going into a curve at high speed can't be avoided, it is recommended that the rider leans his or her body weight slightly inside the direction of the curve to help prevent tipping.*

## GOING UPHILL

Your Trivel has been designed with a wheelbase length that allows a rider to safely take on most inclines. However, it is recommended to avoid inclines over 8% (roughly 5 degrees angle). Before going for a ride that may include big inclines, get to know your itinerary and if needed, look for an alternative route with a gentler incline.



*If the incline is too steep, there is a risk of tipping backwards, which can lead to the loss of the front brake function and/or a risk of serious injuries. It is the responsibility of the user to know his or her itinerary beforehand and plan a safe route. The user must avoid tipping at all time.*

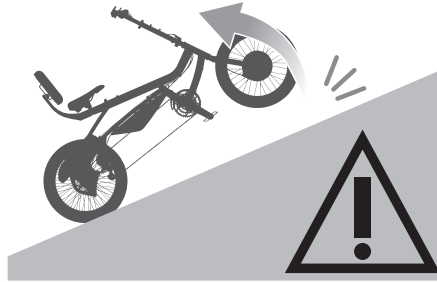

*In a situation where a rider is attempting an incline over the vehicle tipping point limit, it is recommended that the rider leans his or her body weight slightly forward to help prevent tipping.*



## BRAKING

Efficient braking will improve your riding and make you safer. Before your first ride, you should get to know how the brakes work, how powerful and responsive they are, and which side is front, which side is rear.



*Keep in mind that the braking distance needed to come to a complete stop is likely to be longer when riding a Trivel compared with a traditional bicycle.*

## How to brake efficiently

1. Use both front and rear brakes simultaneously
2. Apply force progressively on the brake levers (modulate the braking force in between front and rear brake)
3. Understand that the front brake is responsible for most of the braking duty
4. Avoid putting so much force on the brake levers as to lock the wheel and skid
5. Understand that the braking power is at its peak at the point where the wheel is about to lock but is reduced drastically when it does
6. Anticipate braking time according to your speed, weather condition and the riding track surface

7. Avoid braking while taking a curve. Instead, brake before taking a curve and release brake while turning

## USING GEARS

Knowing how and when to shift gears will make your riding experience better. Shifting gears frequently to adapt your pedalling cadence to your speed can help prevent muscular fatigue, joint injuries, and extend the drivetrain use life.

Your Trivel is equipped with an efficient and reliable gear transmission system. To make the best out of it, you should understand how it works and how to use it properly.

## What's what?

### Shifters (Trigger type) components terminology

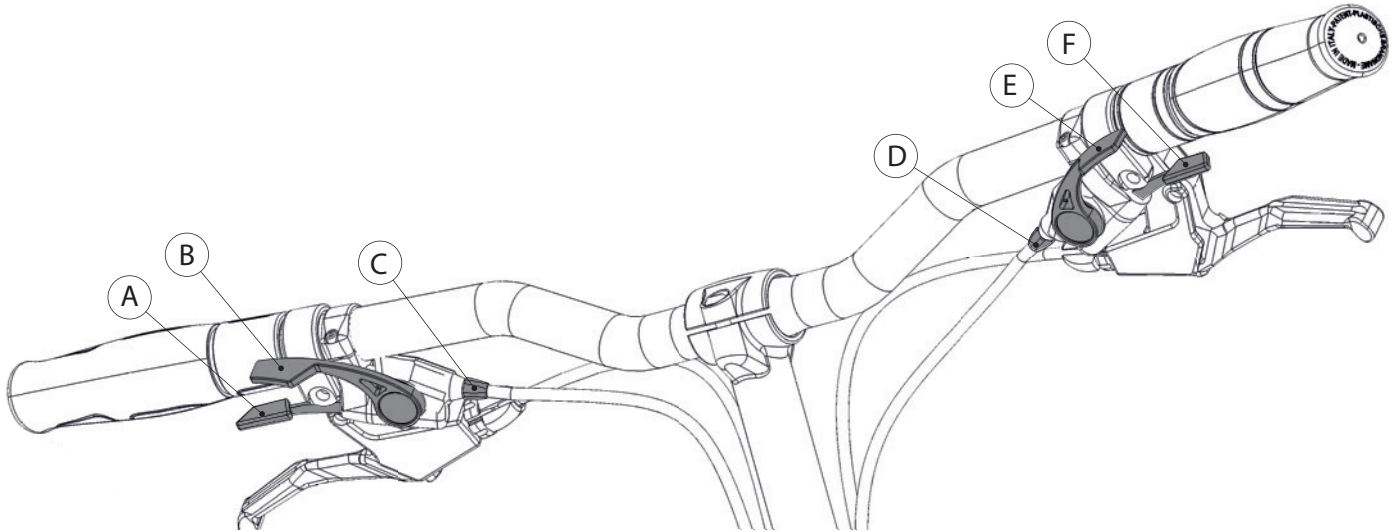

- A. Front derailleur down shift lever
- B. Front derailleur up shift lever
- C. Front derailleur cable tension adjustment barrel

- D. Rear derailleur cable tension adjustment barrel
- E. Rear derailleur down shift lever
- F. Rear derailleur up shift lever

## Gear transmission components terminology

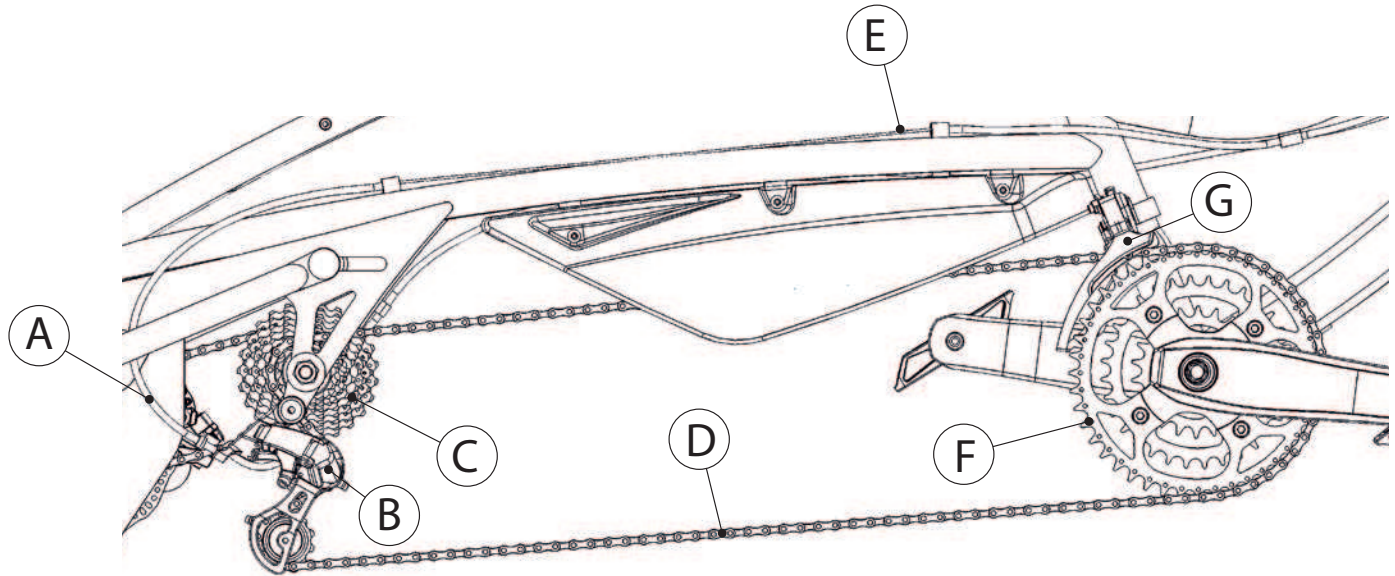

- A. Rear derailleur cable housing
- B. Rear derailleur
- C. Cassette
- D. Chain
- E. Rear derailleur cable

- F. Chainwheel
- G. Front derailleur

## How it works

The shifter levers either pull or release cable, causing the front or rear derailleur to move sideways pushing the chain from a sprocket to another thus operating a change of gear.

A gear change can't be made when the rider is not pedalling.



*There are several types of transmission systems and many possible combinations. If the system fitted on your Trivel is not sufficient for your level of fitness, preferred route, or personal preference, ask a qualified technician for possible upgrades.*

Highest gear combination (Largest front chainwheel/Smallest rear sprocket)

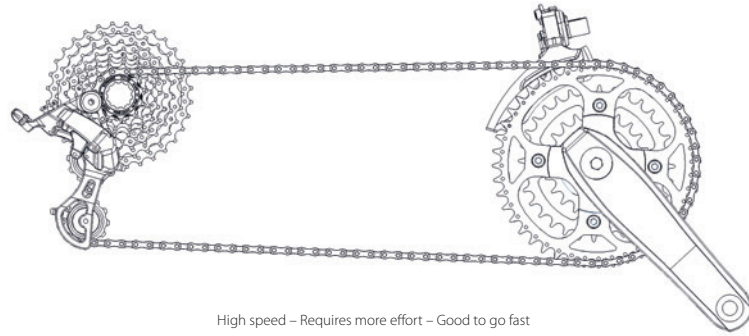

Lowest gear combination (Smallest front chainwheel/Largest rear sprocket)

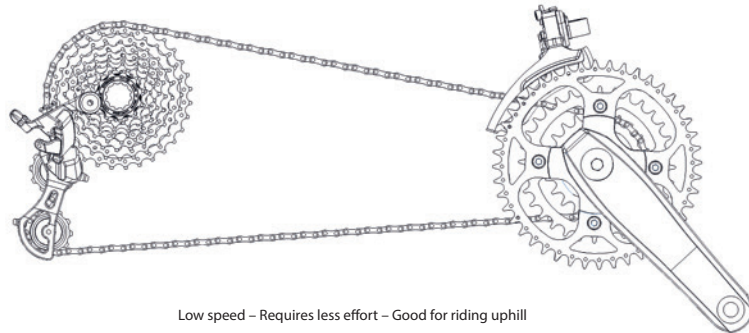

## Shifting up

As you accelerate and gain speed, it is time to shift up if you want to keep going faster. Shift up progressively until you reach your desired speed and comfortable pedalling cadence.

Shift up by small increments with the rear derailleur, using the index lever on your right-hand side.

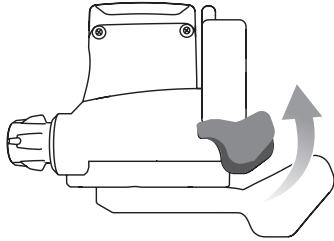

Shift up by a large step with the front derailleur, using the thumb lever on your left-hand side.

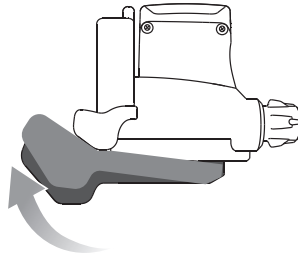

## Shifting down

As the incline or headwind increases, or when fatigue is felt, it takes more effort to pedal. It is then time to shift down to maintain a comfortable pedalling cadence and keep going.

Shift down by small increments with the rear derailleur, using the thumb lever on your right-hand side.

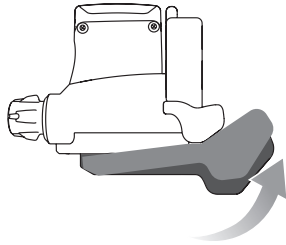

Shift down by a large step with the front derailleur, using the index lever on your left-hand side.

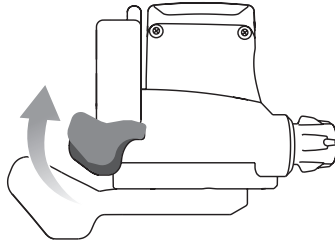

## How to shift gear efficiently

1. Avoid shifting gear when the chain is under heavy tension. Reduce your pedalling power briefly when changing gear.
2. Avoid accelerating on a high gear. Instead, start off with a low gear and shift up progressively to avoid putting too much tension on the chain.
3. Avoid “crossing the chain” by alternating rear derailleur gear change and front derailleur gear change.
4. Think of shifting down before coming to a complete stop so you can start off again on an easy gear and prevent premature wear to the system.



*If the chain suddenly drops from its gear, stop pedalling immediately. Carefully get it back on the gear manually to avoid damaging the frame and components.*

The following gear combinations should be avoided to prevent premature wear of the transmission components:

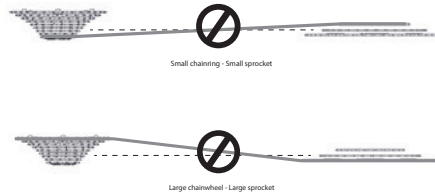

## RIDING IN WET CONDITION

Try to avoid riding in wet weather if possible as this seriously increases the risk of losing control and falling.

Tires contact with the ground and braking efficiency is greatly reduced on wet conditions. Slow down, start braking early and more gently, take extra caution when turning.

Water coming into your eyes can reduce your vision field. Wear proper eyewear.

## RIDING AT NIGHT

Try to avoid riding at night as this adds several risks.

Make sure you are visible to the others and that you can also see them well. Reflectors included with your bike are a minimal safety device and it is recommended that you use a proper set of lights on your bike (Depending on where you live this could be mandatory by the law).

Wear bright colored clothes and equipment and always check to confirm that people see you before attempting a manoeuvre. Always ride defensively and first consider that people don't see you.

## RIDING WITH FEET SECURING DEVICES

Be careful while riding with feet securing devices such as toe-clips or clipless pedals. Although they may help increase your performance, there is a learning period necessary before being able to safely use these devices. Start progressively and adjust the strap tightness or spring accordingly.



# USING THE POWER ASSISTANCE SYSTEM

## SAFETY WARNINGS

The electric power assist system equipped on your Trivel is a safe and reliable set of components that complies with safety regulations.

There are a few safety precautions to follow to minimize the risks and dangers from electrocution, fire hazard and injury.

If your Trivel is equipped with an electric power assist system, please make sure to read and understand the following warnings:



*Do not alter or disassemble any component of the power assist system. Service and maintenance must always be performed by a qualified technician.*



*Always use the original equipment provided to operate and charge the system. For replacement parts, contact Trivel or your dealer.*



*An electric power assisted tricycle handles differently than a human powered only tricycle. The acceleration can be surprisingly effective, and you should get familiar with its behavior progressively before riding on public roads.*



*An electric power assisted tricycle is heavier than a human powered only tricycle. Always keep that in mind when evaluating the required distance needed for braking. It may be longer than what you are used to. This also calls for more attention to the maintenance of your brake system and tires.*



*Always look ahead of you while riding. Avoid looking at the power assist*

*system LCD screen unit for a long period. Learn how to operate the system without looking or with only a quick glance.*



*A power assisted bicycle might not suited for use by children or certain persons with reduced physical or mental capabilities. Make sure to consult a specialist to help you decide whether it is suitable or not.*



*Laws and regulations regarding the speed limitation and use of a power assisted vehicle varies among countries and even sometimes among states and provinces. Make sure you know, understand, and comply to local laws and regulations.*



*Always follow the instructions contained in this manual in the Power assistance system instructions section when operating, charging, and storing the battery or charger unit.*

## NOTICE TO THE USER

Trivel notifies the owner or the user of an electrically assisted vehicle of the Trivel disclaimer of responsibility and of the risks and danger of the use of such a product and of the means to protect against them following its purchase from an authorized Trivel dealer.

### Compliance of products to applicable legislation

Trivel warrants its electrically assisted vehicle conform to laws and norms applicable in the province of Québec, Canada. For any purchase with a view to using it outside the province of Québec, the owner must personally verify the details of the legislation effective in the country, state, territory or province concerned, for the applicable norms, declarations, interdictions and other requirements of said legislations. The liability of Trivel shall not be engaged in case of non-compliance with the legislation of the country, the state, the territory or the province where the product

is delivered and/or utilized, it is the owner's responsibility to check with local authorities.

### Safety precautions during use

Trivel recommends that the owner operate the vehicle and ride it on a closed circuit course for a duration of between six (6) and twelve (12) hours, depending on the user's level of experience, to allow the owner to become familiar with the operation of the vehicle, to develop sufficient knowledge and ability and to become so familiar with it that the user will be provided with a level of safety that is to be expected. Electrically assisted vehicles were not designed, developed, distributed, or sold for professional use or to be used commercially, nor to be used for stunts, ramp acrobatics, jumps, aggressive riding or riding in excessively rigorous conditions such as: winter conditions (with the product in contact with ice, water, salt, sand and calcium) and tropical conditions, (contact with sea salt or riding with heavy loads), or for any other similar activities.

Consequently, non-compliance with these instructions and recommendations renders Trivel warranties null and void and exonerates Trivel from any liability toward the owner.

### Information regarding risks and dangers and ways to guard against them

In order to minimize all risks and dangers from electrocution and to guard against any fire, burn, damage, prejudice, injury or injury that could cause death and that could result directly or indirectly from the battery of the electrically assisted vehicle, the general precautions regarding electrical devices are applicable. The slightest electrical discharge can cause serious injuries and you must read all the instructions with care. Without limiting the generality of the preceding, and in addition to the instructions in the Owner's Manual, Trivel recommends that you never touch hot surfaces, use only the battery and the original charger recommended by Trivel, always use the specific charging equipment to

charge the battery, never expose the battery or the charger to heat, never dismantle or modify the battery or the charger, do not expose the battery or the charger to liquids, do not use a damaged battery or charger, stop charging the battery if the charge is incomplete at the end of the theoretical charging time, stop use of the battery and charger if they emit an unusual odour, become hotter than usual or if something seems abnormal, never leave the battery and charger where they can be reached by children, and here we urge that extreme vigilance is necessary in this regard, never touch the battery or charger with wet hands, never turn on the battery or charger if they have damaged cables or tie downs or if the battery or charger have any kind of malfunction or have been damaged in any way, always take the battery and charger back to the dealer for maintenance, examination, repair or setting, always make sure to correctly connect the charger to the battery and the charger only to alternating current of 110V A.C., do not use a battery or charger if they are dusty, do not use the charger with other than

the specified current, do personally check the battery and charger for any damage, do not leave the battery and charger near an electrical heating appliance, a gas or microwave appliance, do not touch the charger or the battery for too long during battery charging, do not position the charger or the battery in an unstable manner and do not cover the battery or the charger or hang anything from them and never use the battery and charger for any use other than the one for which they have been designed.

In order to minimize all risks and dangers and to guard against any damage, prejudice, injury and injury that could cause death, Trivel recommends to the owner to ride carefully on bicycle paths and not on public roads.

Even if the local competent authorities allow riding on public roads, the owner will do so at his or her risk and peril. In addition to the general rules that apply to riding on bicycle paths or public roads, the Highway Safety Code, L.R.Q. chap. C-24.2 contains special

provisions for users of electrically assisted vehicles and these must be followed to protect against all risks and dangers that are inherent to the use of such vehicles.

The equipment must be checked periodically by your dealer as part of regular maintenance and to spot stress and/or potential failures including but without limiting the generality of the preceding, cracks, deformations, corrosion, paint chipping dents and for any other indications of potential problems, improper use or abuse. These periodic inspections are proven essential safety measures that can prevent accidents and injuries to the owner.

Negligence or non-compliance with these regulations can cause serious injuries to the owner and may, in certain cases, cause death. Consequently, non-compliance with these instructions and recommendations renders the warranties given by Trivel null and void and exonerates Trivel from all liability toward the owner.

## General disclaimer of responsibility

Trivel shall not be responsible for damages of any kind, whether material, immaterial or corporal, sustained by the owner including loss of time, loss of income, trouble and inconvenience that might result from:

1. Improper operation of the vehicle
2. Non-compliance with the instructions and recommendations contained in this notice  
Any handling-related incident whether involving error or not
3. Any abnormal use or use which does not conform to the vehicle's designed purpose.
4. Any cause of exterior origin

Trivel advises the owner that using an electrically assisted vehicle entails inherent risks and dangers that the owner agrees to assume completely whatever their nature. The owner accepts to hold Trivel harmless from any liability and to solely assume liability for any damage of whatever nature that he might sustain or that he or she might cause to a third party.

The owner renounces any claim and any procedure, of whatever nature, against Trivel, in the event of losses, damages or injuries of any kind that he or she might sustain while using the equipment and this applies before, during and after said use.

## Applicable laws and competent tribunals

All disputes or disagreements that might arise following the purchase of the electrically assisted vehicle from a dealer shall be subject to the laws that apply in the province of Québec, Canada. Parties shall elect domicile in the Montréal Judicial District, province of Québec, for the hearing of any claim pertaining to interpretation, application, conclusion, terms, validity and effects of the warranty.

## DESCRIPTION OF THE COMPONENTS

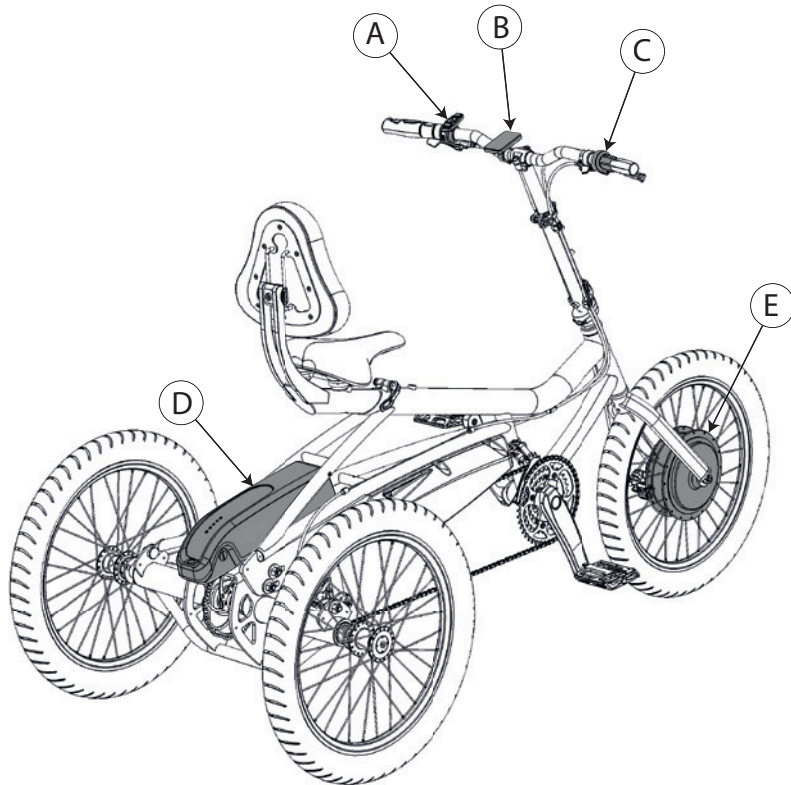

- A. Controller
- B. LCD Panel
- C. Throttle
- D. Battery
- E. Hub motor

## Controller

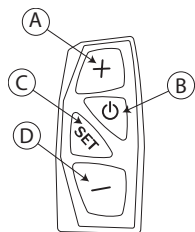

- A. Upbutton
- B. Power button
- C. Setting/Mode button
- D. Down button

## LCD Panel

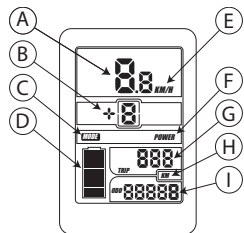

- A. Current speed
- B. Current power assist mode
- C. Current mode
- D. Battery charge level
- E. Speed unit
- F. System status
- G. Trip distance
- H. Odometer unit
- I. Odometer

## Battery

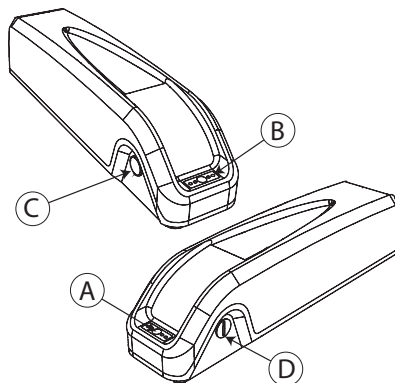

- A. Battery level check button
- B. LED battery level indicator
- C. Charging port
- D. Key lock

Type: Lithium-Ion,  
Quick charge Rated Voltage: 48V  
Current: 10.4A  
Capacity: 500Wh  
Operating temperature: 0°C to 30°C (32°F to 86°F)  
Storing temperature range: 10°C to 25°C  
(50°F to 77°C)

## Charger unit

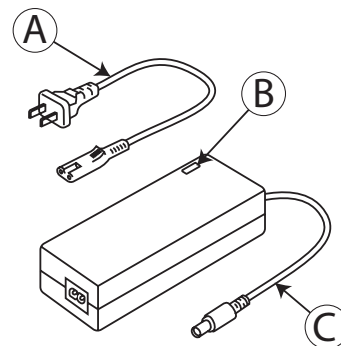

- A. AC Power cord
- B. Charger status LED indicator
- C. Charging plug

## Throttle

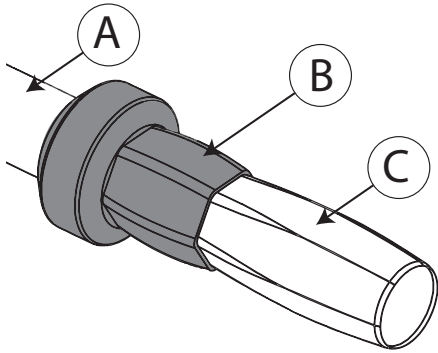

- A. Handlebar
- B. Throttle
- C. Grip

## Hub motor\*

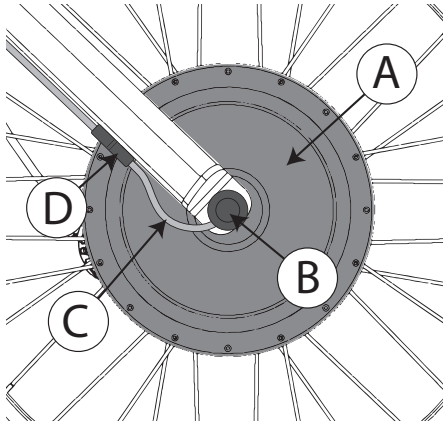

- A. Hub motor casing
- B. Axle nut cover
- C. Power cord
- D. Power cord coupler

*\* All specifications listed above are subject to change without notice.*

## GETTING STARTED

### Step 1: Charge the battery

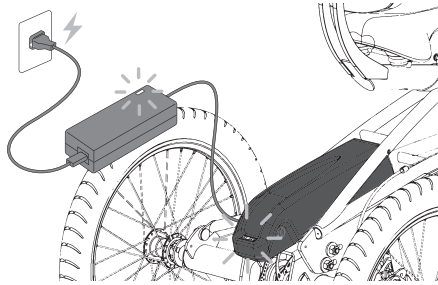

1. Connect the AC power plug into the charger.
2. Plug the AC power plug into an electrical outlet. The LED indicators on the charger will light up.
3. Connect the charging plug into the battery's left side charging port. The LED indicators on the battery will blink, confirming that charging is underway. Let the battery charge until it is full.
4. The light on the charger will turn green when fully charged.
5. Pull the charging plug from the battery port and replace the rubber protector cap.

### Step 2: Adjust your position

1. Slide the seat beam back or forth into the frame so you have a proper leg extension. See section [Setting your seat position](#) for instructions.
2. Move the backrest support up or down along the rail and adjust the angle to your preference. See section [Setting the backrest height and angle](#) for instructions.
3. Raise or lower the upper stem assembly to find a comfortable handlebar height.
4. Make sure all the tightening levers and bolts are tight.

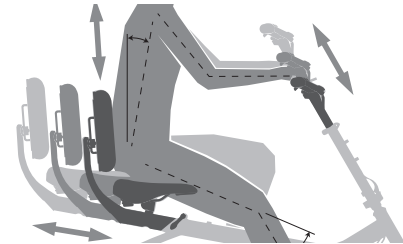



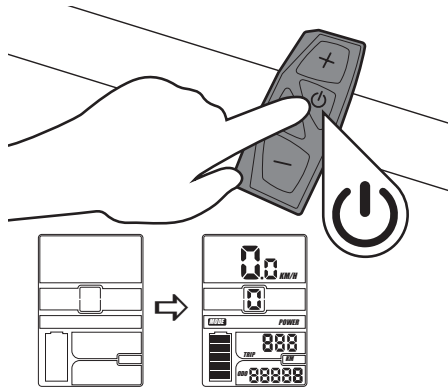

### Step 3: Turn the system ON



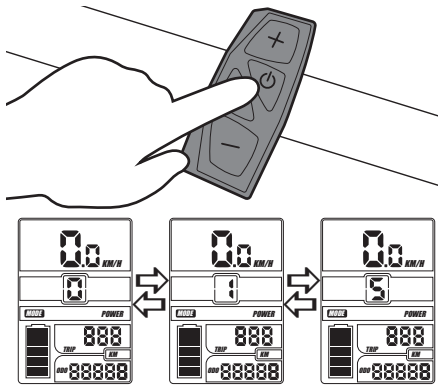

1. Get seated and put at least one foot on the ground.
2. Press the  Power button on the controller until the LCD Panel lights up.

### Step 4: Choose an assistance level



1. Press the  button on the controller to switch to a higher power assistance level (0 to 5).
2. Press the  button on the controller to switch to a lower power assistance level.

 *Level 1 provides the least power assistance, while level 5 provides the most. Level 0 provides no power assistance.*

 *Be careful if you choose to start off with a high level of power assistance as the first pedal stroke may result in a surprisingly powerful acceleration.*

## Step 5: Start off!

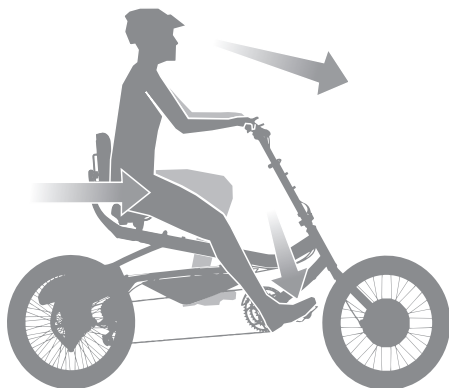

1. Make sure the way is clear in front of you.
2. Hold on firmly to the handlebar and push on the pedals. The power assistance will kick in quickly.



*Make sure the battery is securely locked on the frame before getting started!*



*Every time the power assistance system is turned OFF, the assistance mode and level will reset and return to 0 once the system is turned ON again.*



*Check your battery charge level before going for a ride! Don't run out of power far away from home!*

## USING THE LCD PANEL FUNCTIONS

### Turning the LCD Panel ON

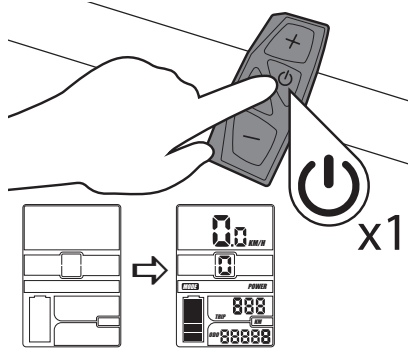



Press the  Power button on the controller to turn the LCD Panel ON.

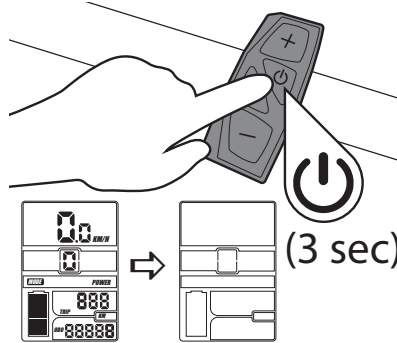

*The LCD Panel with shut down automatically after 5 minutes without operation or input in order to save battery capacity.*

### Turning the LCD Panel OFF



Press and hold the  Power button on the controller for 3 seconds to turn the LCD Panel OFF.

### Activate the backlight

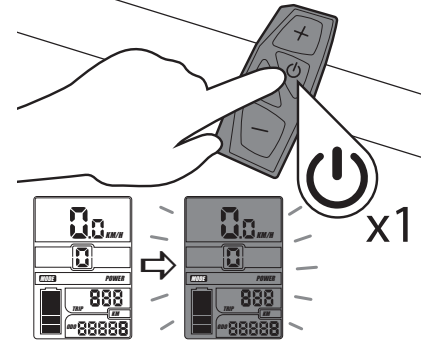

Once the LCD Panel has been turned ON, shortly press the  Power button on the controller to turn backlight ON.

## Deactivating the backlight

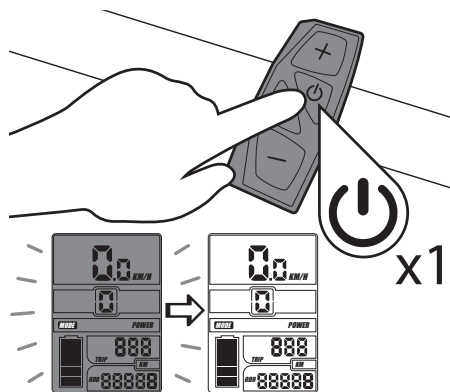

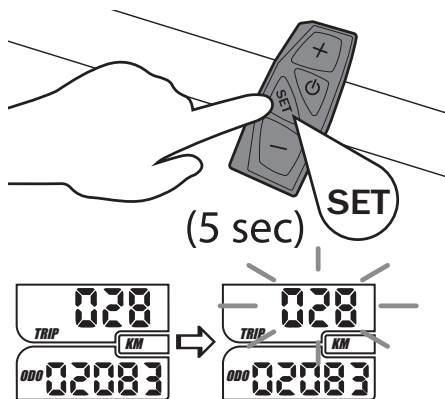

Once the backlight has been turned ON, shortly press the  Power button on the controller to turn it OFF.

## To clear the Trip Distance value

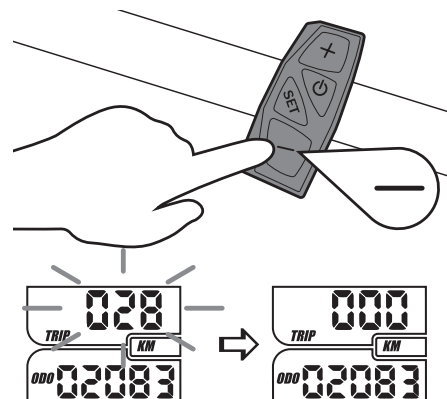

1. While the LCD Panel is ON, press and hold the  Set button on the controller for 5 seconds until the Trip Distance value flashes.



2. Then shortly press the  button to reset the value to zero.

To change the speed and distance unit

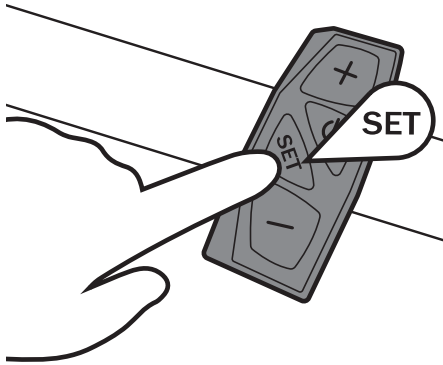
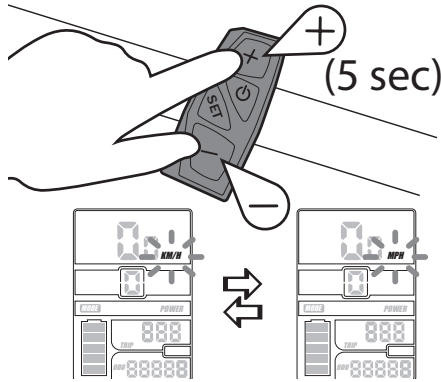



1. While the LCD Panel is ON, press and hold simultaneously both the **-** and **+** buttons on the controller for 5 seconds until the Unit value flashes.
2. Switch to the desired Unit (Km/h or Mph) using the **-** and **+** buttons
3. Then shortly press the **SET** button to save the new Unit to be displayed.

## TURNING THE POWER ASSIST SYSTEM ON

To activate the power assistance system, press the  power button on the controller. The LCD panel will light on and show Assistance mode 0.

## CHOOSING AN ASSISTANCE MODE

The LCD Panel unit shows which mode you're in. Use a power assistance level according to the current riding conditions. Use a higher assistance level when going uphill or against a head wind and switch to a lower assistance level if you are riding on a flat road or with a tail wind to save your battery.

Switch through power assist modes using the  and  buttons on the controller.



*Assistance mode: Use this mode whenever you wish to benefit from electrical assistance, which makes pedalling easier. Compared to No-pedalling mode, this mode gives you longer range for the same charge.*

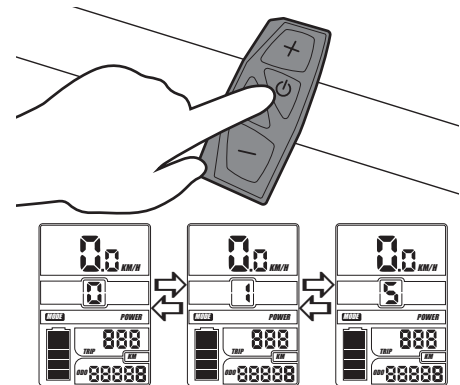

## Mode 0

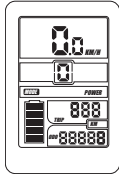

This is the mode when you pedal without throttle or any assistance, the motor will never turn ON.

## Mode 1

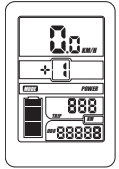

When pedalling, the motor gives you assistance up to 10 Km/h (6 mph). This means moving forward at low speed on a level road, for example, will require slightly less effort.

## Mode 2

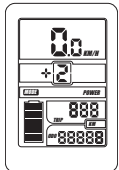

When pedalling, the motor gives you assistance up to 15 Km/h (10 mph). This means less effort for you if you are travelling at low speed on a level road with a slight headwind.

## Mode 3

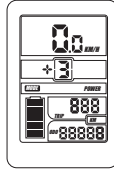

When pedalling, the motor gives you assistance up to 20 Km/h (12 mph). This means you will not have to exert yourself as much to go up a slight hill.

## Mode 4

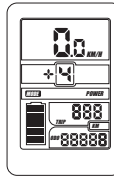

When pedalling, the motor gives you assistance up to 25 Km/h (15 mph). This will help you go up a good-sized hill.

## Mode 5

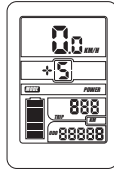

When pedalling, the motor gives you assistance up to 30 Km/h (19 mph). This means you will find it easier to go up steep hills or move forward against strong headwinds.

## No-Pedalling mode

From a stop or while in motion, simply turn the Throttle Handle (on the right) to move forward. To reach the top of some of the hills, it may be possible to have to pedal as well.



*The No-Pedalling mode might not be available in some area, depending on the local regulations!*

The range will be reduced depending on the type of roadway, the number of slopes and the degrees of inclination, the direction and the force of wind, the tire pressure and the weight of the user.

## Manual mode without pedal-assistance or throttle

When you select the 0 mode from the LCD Panel, the Assistance and the Throttle will not be active, but you will have access to the Panel information, speed, distance, etc.

To turn the electrical power OFF entirely, simply press the -/O on the right side of the battery.



*Cruise control: This mode allows you to maintain a steady desired speed without pedalling.*

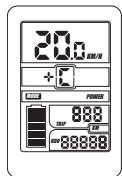

## To activate Cruise control mode:

Turn the Throttle Handle (on right handlebar) until the desired speed is attained, maintain this speed for a few seconds then press  button until you see a "C" on the LCD panel then you can release the button the Cruise control is activate. You can now release the Throttle Handle and the speed will be maintained.

To deactivate the Cruise Control, simply press one of the brake levers.



## OPERATING RANGE AND BATTERY USAGE OPTIMISATION

### Operating range

The estimated operating range\* of your electrically assisted Trivel is as below:

1. Under No Pedalling Mode: 15 to 40 km
2. Under Level 2 Pedal Assist Mode: 50 to 90 km

*\*Unfortunately, it is impossible to provide a perfectly precise operating range value for a battery charge as there are numerous unforeseeable factors involved in every type of terrain, rider behavior, equipment adjustment, battery condition and weather hazards. These estimated distances were calculated under ideal conditions. As for an 85 kg or 187 lbs. person riding on paved and level roads, without headwinds, and with tires inflated to manufacturer's specifications (see recommended pressure on side of tire), and riding at a steady speed of 20 km/h.*



*The distance you can ride with a single battery charge varies greatly depending on several factors. Selected power assistance mode, road incline, wind strength, and air temperature amongst other factors, affect the battery autonomy. Irregular ground types also influence your operating range. Per example, a loose ground surface such as a gravel road increase the tires rolling resistance and therefore require more power, thus quickly reducing battery power.*

### Battery usage optimisation

There are a few things that can help you make the most of a battery charge:

1. Use the power assistance mode you need for each condition during your ride (you may not need maximum assistance while riding on flat ground or with a tail wind).
2. Down shift to a lower gear before coming to a complete stop, then you can start off again on an easy gear combination and shift up progressively as you gain speed. This will make it much easier for the motor to assist your acceleration and help preserve your transmission components as well.
3. Keep your tires inflated at the recommended pressure (this will significantly reduce the rolling resistance of your tires and require less power from the battery).
4. Only bring the necessary equipment to keep your overall weight as low as possible.

## REMOVING OR INSERTING THE BATTERY

It is recommended to remove the battery from the frame for charging or for storing it for a long period.

To remove the battery:

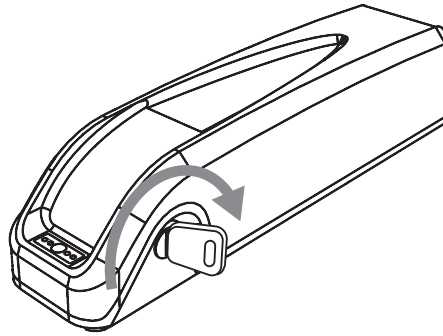

1. Insert the key into the key lock of the battery.
2. Turn the key for half a turn, counter clockwise (to the left) to unlock the battery.

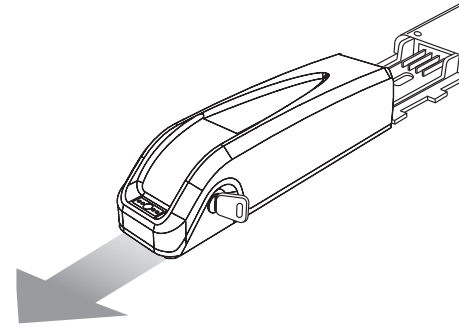

3. Firmly and carefully pull the battery along the battery holder bracket towards the back.

## To Insert the battery:

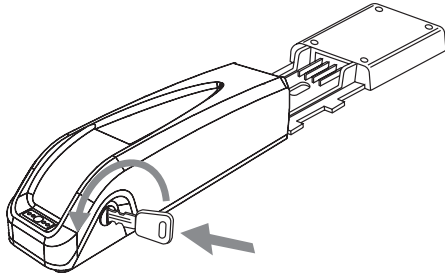

1. Insert the key into the key lock of the battery.
2. Turn the key for half a turn, counter clockwise (to the left) to unlock the battery.

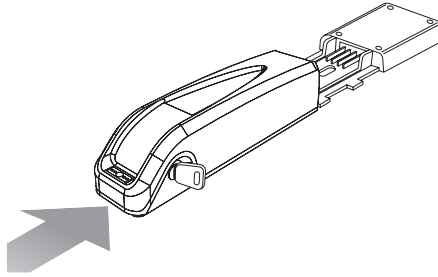

3. Check the battery holder bracket to ensure there isn't any water or dirt accumulation on the connectors.
4. Carefully align and push firmly on the battery along the battery holder bracket towards its stopper.

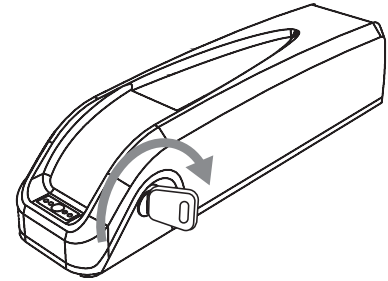

5. Turn the key for half a turn, clockwise (to the right) to lock the battery in position.

## CHARGING THE BATTERY OF YOUR ELECTRIC POWER ASSIST SYSTEM

### When should the battery be charged?

It is recommended to charge the battery as needed. For instance, if you only use your electric vehicle during brief periods of time and for short rides, the battery may be recharged following several such rides.

If, on the other hand, you are planning a long ride of 40 km/25 miles or more, it is recommended to fully charge your battery before leaving.

Generally speaking, if the battery charge indicator on the handlebar or on the battery indicates there is less than a 50% charge remaining, charging of the battery is recommended.

You may charge your battery at any time, as this type of battery does not have any 'memory effect' and the charger is of the 'smart type'; it will stop charging by itself once the battery is fully charged.

The battery must be charged at least every two months.



*A full charge of a battery when empty should take a maximum of 8 hours to complete.*



*If your battery is not fully charged after 8 hours, unplug it immediately and contact a Trivel authorized dealer for a charger battery malfunction diagnostic.*



*Never leave the battery connected to the charger for more than 24 hours!*

### To charge the battery:

1. Connect the AC power plug into the charger.
2. Plug the AC power plug into an electrical outlet. Check that the LED indicator on the charger lights up to confirm that power is going through.
3. Lift the rubber protector cap and Connect the charging plug into the socket on the battery.
4. Check that the LED indicators on the battery are flashing to confirm that charging is underway.
5. Let battery charge until it is fully charged.
6. Pull the charging plug from the battery and replace the rubber protector cap.

## STORING THE BATTERY

### What should be done to maintain the battery in good condition?

During the long periods when you will not be using your Trivel such as the winter season, store the battery inside your house after charging it completely for 8 hours; afterward, you must charge your battery for one hour each month or for two hours every two months.



*Always use the lithium charger supplied by Trivel with a Trivel lithium battery, otherwise your charger and your battery might be damaged.*

### How to store the battery?

Do not expose it to extremes of heat (more than 40°C / 105°F) or cold (-10°C / 14°F) or to damp conditions (rain, water, garage, shed, hangar or unheated basement).

Even though your battery is of the so-called 'no-memory' type, it is advisable to recondition it at regular intervals by running it down and recharging it completely (8 hours).



*Avoid using an electrically assisted vehicle during extreme conditions (for your safety and for proper functioning of the equipment). Avoid salt, sand, calcium, water and ice and your system will perform much better. using your bicycle in such conditions would void your warranty.*



*Never leave the battery connected to the charger and to electrical power outlet for more than 24 hours. This could damage the charger and the battery. Never connect your battery and your charger to an electrical outlet for an overly long period of time (during the whole winter for instance). This will damage your battery and your charger. this must absolutely be avoided.*

## MINIMUM BATTERY MAINTENANCE SCHEDULE

It is essential that you look after your battery maintenance at regular intervals. This is particularly important during the off season, when you are likely not using your Trivel for long periods.

### 48V Lithium Battery

Your battery must maintain a minimum voltage of 40 volts. If the voltage goes below 30 volts, the battery could become irrecoverably damaged and might no longer be able to accept a full charge.

**To keep the battery under proper warranty, follow this maintenance procedure:**

If using your Trivel seasonably, following your last long ride of the season, you should immediately charge your battery for eight (8) hours. Then, during the off months, charge the battery for 2 hours every two months.

## TROUBLESHOOTING (ELECTRIC ASSISTANCE SYSTEM)

### Error codes

When the system detects an abnormality, the power assistance will be interrupted, and the LCD Panel will display an error code. Below is a list of error codes and their relative description. It can be used for reference in order to help communicate with a technician.

The power assistance system will not be functional again until the issue is addressed and solved. Do not ride your Trivel if an error code shows up until it is solved.

Please communicate with a qualified technician and book an appointment for service when an error code shows up.

ERROR CODE	DESCRIPTION
2	Current abnormality or damaged operating system
3	<i>Motor locked up</i>
4	<i>Low voltage</i>
5	<i>Brake sensor abnormality</i>
6	<i>Motor abnormality</i>
7	<i>Throttle abnormality</i>
8	<i>Error 358</i>
9	<i>Over voltage</i>
10	<i>Communication with controller abnormality</i>
15	<i>Communication with LCD Panel abnormality</i>

## MAINTENANCE AND ADJUSTMENTS

Proper and regular maintenance of your Trivel is key for your safety and to ensure good functionality of the mechanical components over time. Follow these instructions and make sure to take your Trivel to your dealer for evaluation and servicing at regular intervals.

Many regular maintenance operations and adjustments can be accomplished at home with only a few tools. If you are not familiar with tools and bicycle mechanics or if you are not entirely confident with your skills, we strongly recommend that you ask someone with the proper skills and experience to help you. A qualified technician at your dealer can also help you for that task.

Note that some adjustments and repairs are better left to a qualified technician.

These operations either require specific tools or expertise that only an approved Trivel dealer have and therefore, we strongly recommend that they are only accomplished by one. These adjustments or repairs will be noted as such in this chapter.

To learn more, contact your Trivel representative.



*A qualified Trivel technician must ensure the initial adjustment of your Trivel.*



*Do not tighten screws with air or electric tools; the final tightening must be manual.*



*Do not modify the frame in any way. Drilling and grinding can cause severe structure damages and will automatically cancel the guarantee.*



*Do not use any locking rings other than those designed and approved by Trivel.*



*The latest version of this manual is available on our website at [www.trivel.com](http://www.trivel.com)*



## TOOLS, PRODUCTS AND PROTECTIVE GEAR NEEDED



*All of these tools might not be needed depending on your Trivel model specifications.*



*Some tools not listed here might also be needed depending on your Trivel model specifications.*



*Trivel components and accessories use metric size standard hardware. Do not attempt to perform mechanical work with other sizes of tools or hardware, you may damage bolts and components.*



*Maintenance of your Trivel requires to handle some chemical products that can be hazardous to your health. Make sure to follow the products safety recommendations and wear adequate protective gear when doing some mechanical work and maintenance.*

## Tools

1. Screwdriver for Phillips head bolts (small and medium sizes)
2. Metric Allen keys (sizes 2 mm to 8 mm)
3. Metric wrench keys (sizes 8 mm to 17 mm)
4. Torque wrench (low torque range)
5. Air pump with pressure gauge

## Lubricants and cleaning products

1. Bio chain lubricant (wet or dry grade)
2. Bio degreaser spray for metal parts
3. Lubricant spray for metal parts
4. PTFE lubricant
5. Isopropyl alcohol spray

## Protective gear

1. Protective vinyl gloves
2. Protective goggles
3. Mechanics apron
4. Clean rags

## PREVENTIVE MAINTENANCE

1. Always maintain tire pressure as recommended by manufacturer. You'll find this information on the tire's sidewall.
2. Ensure gearing systems are well lubricated
3. Make sure all nuts and bolts are tightened
4. Clean tricycle after riding in calcium or salt to prevent corrosion
5. Protect tricycle from rain and snow
6. Check brakes regularly to ensure safe braking

## TIRE PRESSURE ADJUSTMENT

Regularly check the pressure of your tires so that they have the correct pressure as recommended by the manufacturer (the recommended pressure is shown on the side of the tire as shown below):



*Riding with insufficient pressure could reduce the autonomy of the power assist system.*

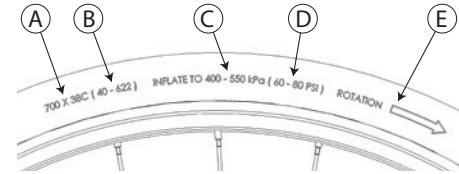

- A. Commercial tire size naming (ex: 16x1.25, 20x2.10, 24x1.95, 26x1.95, 700x38C, etc.)
- B. International standard ETRTO tire size naming (tire and rim width per diameter interface, in millimeters)
- C. Manufacturer's recommended tire pressure range (kPa unit)
- D. Manufacturer's recommended tire pressure range (PSI unit)
- E. Tire's intended rotation direction



*Riding with an insufficient pressure can lead to a puncture of the inner tube and / or damage to the tire and rim.*

## Identifying the type of valve your Trivel is fitted with:

There are two major modern types of valves; Presta (French) or Schrader (American). The illustration below shows the difference.

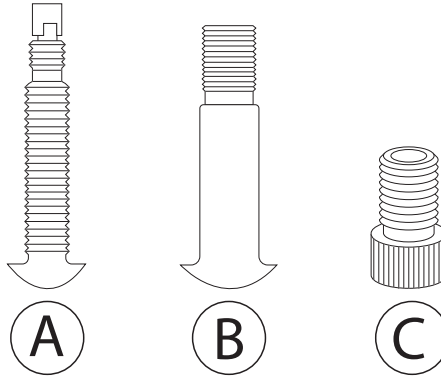



*Most bicycle pumps can be used with both types of valves, whether it is through a dual-type pump head or by reorienting the pump's head rubber joint. Ask a qualified technician if unsure how to use a pump.*

- A. Presta valve (also known as French type)
- B. Schrader valve (also known as American type)
- C. An adaptor can be used to transform a Presta valve into Schrader valve.

## CHANGING A PUNCTURED INNER TUBE

You might eventually experience a sudden or slow loss of air pressure from a wheel. It may come from rolling over sharp objects such as broken glass, thorns, etc. or hitting an obstacle with insufficient air pressure. In both cases, the inner tube has been punctured and will need to be fixed or replaced.

 *It is normal for a wheel to lose air pressure after some time. You may notice after a long period of storage that the tires are almost completely flat. That doesn't mean you need to change the inner tube. Re-inflate your tire to the recommended tire pressure from time to time to avoid puncture.*

 *We strongly recommend replacing a punctured inner tube by a new one instead of attempting to patch repair an old tube. The reason is that a tube repair is often weak, and air can often leak from a repaired tube. A new tube is a time saving, rather cheap and safe solution. Don't worry, your old tube will get recycled if you leave it at a bike shop. Alternatively, it is also possible to use it as an attachment strap.*

 *For a front wheel flat or tire replacement on a model equipped with an electrical power assistance system, the front wheel will have to be removed with the motor. Only a Trivel-trained person is qualified to perform this work without causing damages. It is thus strongly recommended that the owner contact an authorized Trivel representative to have the work performed. Should this not be done, the owner shall not hold the company liable for any damages caused by an improper procedure by a person who is unqualified and not authorized by Trivel.*

## What material will you need?

1. A puncture repair kit or a compatible new inner tube (make sure to purchase a compatible tube by giving all the relevant information regarding the size of the tire and type of valve at the moment of purchase).
2. A set of tire levers (bike tire specific model in plastic material is recommended, do not use metallic motocross tire levers or a screwdriver as it will likely damage the tube and / or rim).
3. An air pump designed for bicycle use with a pressure gauge.

## Follow this procedure to get back on track:

1. (Front wheel): Remove the wheel from the fork.(Rear wheels): Lift the rear end of the Trivel and proceed without removing the wheel from the frame.
2. Detach the tire from the rim first using tire levers
3. Remove the inner tube and locate the puncture
4. Find the corresponding location of the puncture outside and inside the tire
5. Check for any sharp objects remaining stuck in the tire (if any, remove it or replace tire if its too damaged)
6. Fix the punctured inner tube with a puncture repair kit or get a new one
7. Pre-inflate the new or repaired inner tube to a low pressure just enough so it stays round
8. Insert the inner tube inside the tire
9. Put the tire back on the rim making sure the tire thread is facing forward
10. Inflate tire to recommended pressure while checking for an even position of the tire on the rim
11. (Front wheel): Replace the wheel inside the fork

## BRAKE ADJUSTMENTS

A view of a typical braking system (cable actuated disc brake system shown)

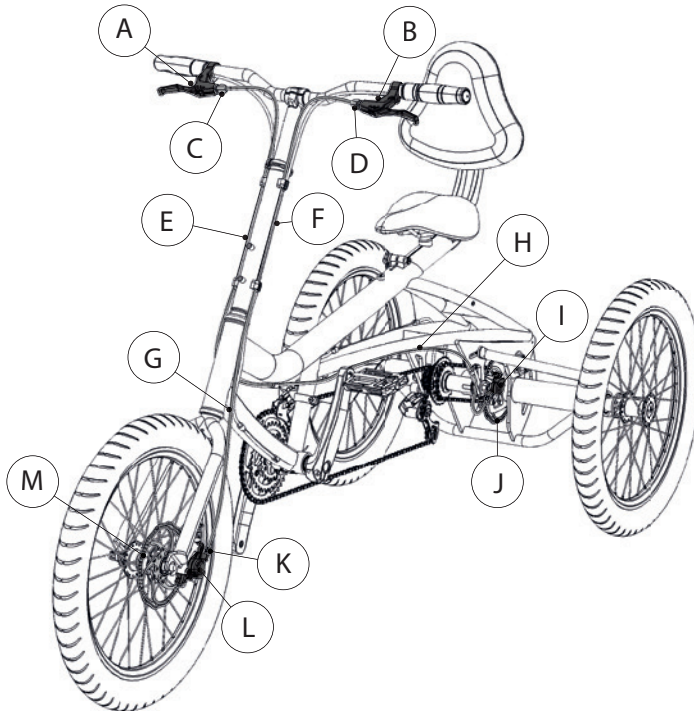

- A. Rear brake lever\*
- B. Front brake lever\*
- C. Rear brake lever adjuster barrel
- D. Front brake lever adjuster barrel
- E. Rear brake cable
- F. Front brake cable
- G. Front brake cable housing
- H. Rear brake cable housing
- I. Rear brake caliper
- J. Rear brake rotor
- K. Front brake adjuster barrel
- L. Front brake caliper
- M. Front brake rotor

*\*Front and rear brake side position may be different in some countries (i.e.: Australia, New Zealand, UK, Japan, etc.)*

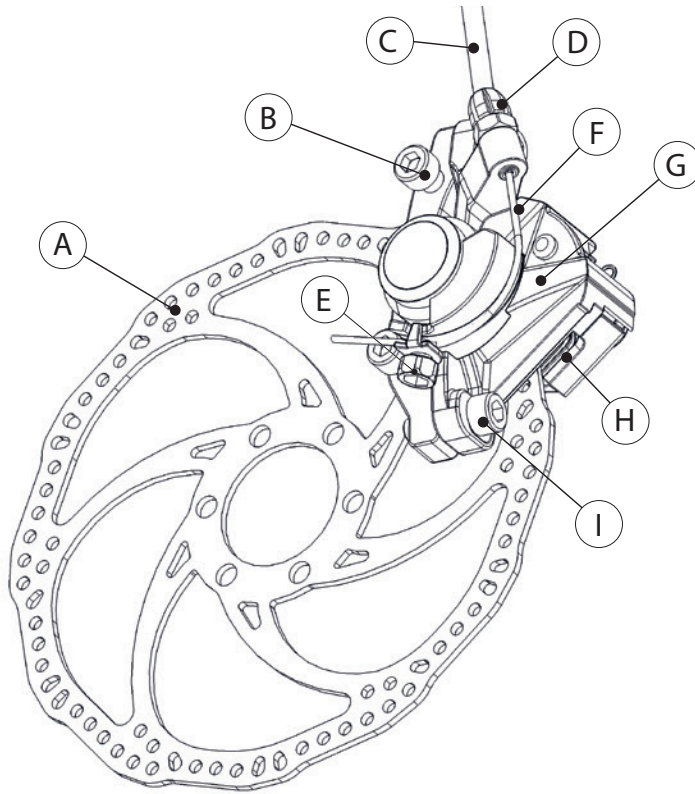

- A. Rotor
- B. Caliper attachment bolts
- C. Cable housing
- D. Cable tension adjustment barrel
- E. Cable pinching bolt
- F. Cable
- G. Caliper body
- H. Brake pads
- I. Caliper centering bolts

*Components of a Disc Brake*

The brake pads should be replaced by a qualified technician when their material thickness have reached 1 mm or below or if they have been contaminated by oil or grease!

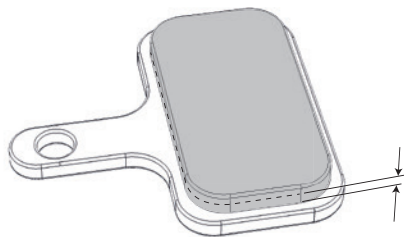

The brakes on your Trivel have been minutely adjusted by a qualified technician before being handed to you at the time of purchase.

It is normal, however, for brakes to wear off with time and their power will fade out as the brake pads material diminish. For this reason, and for your safety, it is necessary to check your brakes before each ride and adjust them if needed.

### Check the brakes function:

Firmly pull the brakes levers. There should be a gap of at least 1 cm between the grip and the lever and the vehicle should not move when pushed back or forth.

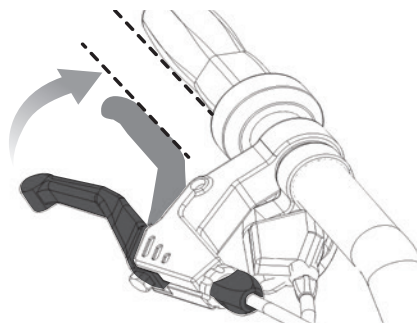

If these conditions are not met, do not use your Trivel before having fixed the issue! Begin with a basic cable tension and brake pads position adjustment.



*Do not attempt to adjust the brakes by yourself if you don't fully understand this section or if you are not confident in your mechanical skills. We strongly recommend that you only have your brakes adjusted by a qualified technician. Poorly adjusted brakes can lead to a loss of control and result in serious injuries.*

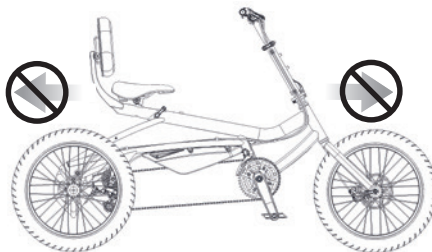



## To adjust the brake pads position:

Adjust both brake pads position (outboard and inboard) so they sit as close as possible to the rotor without rubbing it when the wheel is spinning.

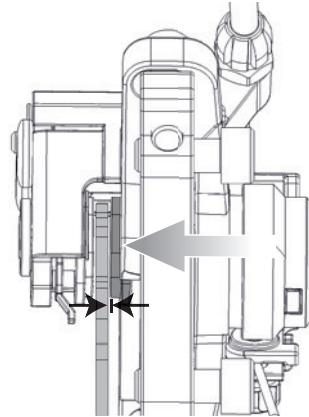
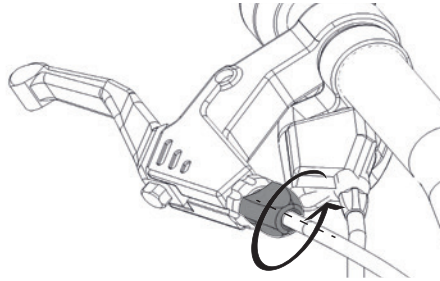

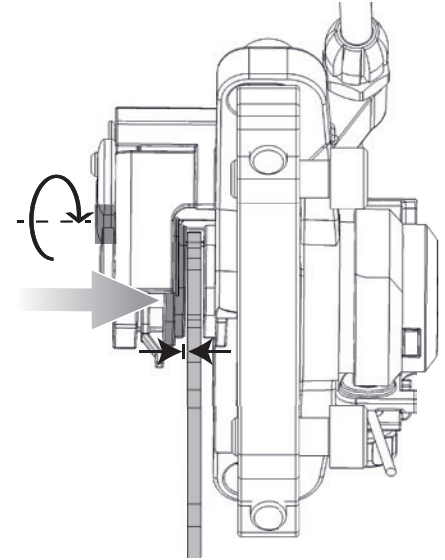

1. Turn the adjustment barrel on the brake lever counter clockwise to move the outboard brake pad closer to the rotor.





2. Move the inboard brake pad closer to the rotor by using the corresponding tool or knob on the inboard piston clockwise (Loosen the anti-rotation set screw if there's one first, and make sure to tighten it again after the adjustment).

If these adjustments did not fix the braking power issue, do not ride your Trivel before having it inspected by a qualified technician!

 Models equipped with hydraulic brakes do not require this last adjustment as the oil pressure in the system will maintain a steady braking power until the brake pads have worn out and need to be replaced. It is however possible to adjust the brake lever reach if needed. Refer to your brake model manufacturer's instructions.

 Disc brakes have a burn-in period until they reach their maximal power. Make sure you understand this phenomenon and expect a change in braking power from the moment of purchase or replacement of brake pads and later use.

 Never touch a disc rotor that is moving or immediately after its use. The disc heats up significantly when braking and this could lead to serious injuries.

 Hydraulic disc brakes are very powerful, and the user should be especially careful when using them. A small force on the brake lever results in powerful braking so make sure you only apply moderate, progressive force to the brake levers. If someone should use your Trivel, it is recommended that you also advise them about this characteristic.

 When hydraulic disc brakes are used continuously (ex. going down a long descent), the fluid inside the circuit will heat up and can cause a phenomenon called "vapour lock". Heat build up significantly reduces braking force until the brake is released and allowed to cool down. Prolonged overheating can damage the brake. If you plan to go down long descents often, it is recommended that you use a larger diameter of disc helping to dissipate heat quicker or a heavy-duty designed disc brake model.

## DERAILLEURS ADJUSTMENTS



*We recommend that you do not attempt to adjust the derailleurs by yourself if you don't fully understand this section or if you are not confident in your mechanical skills. A poorly adjusted derailleur can damage the transmission system.*

Both front and rear derailleurs on your Trivel have been minutely adjusted by a qualified technician before being handed to you at the time of purchase.

After a few rides however, the cables can stretch out a little bit and readjustment of their tension become necessary for optimal derailleur alignment with the gears and shifting performance.

Adjusting a derailleur alignment with the gears by correcting the cable tension is somehow simple and can be achieved without any tool.

Here's how to check if it is necessary to adjust front and rear derailleur alignment and how to fine tune the cable tension.

To check the rear derailleur's alignment:

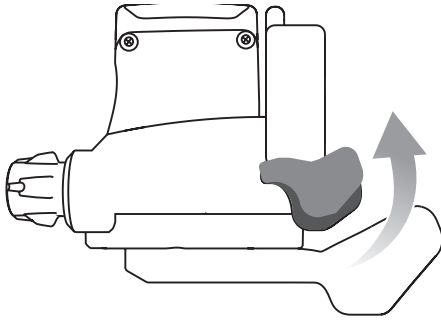

1. Use the right-hand side shifter to put the chain on the highest rear gear (smallest sprocket on the freewheel).

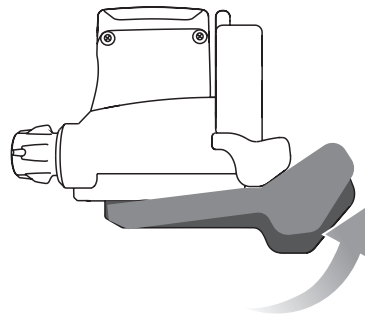

2. Shift down of one gear by pushing a single click on the shifter's thumb lever.

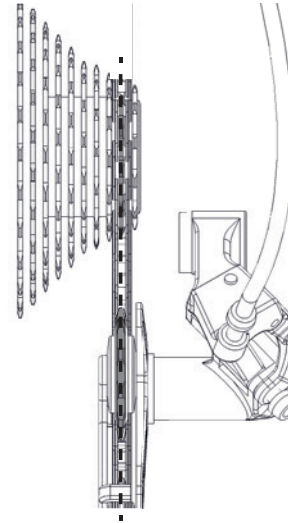

3. Check that the rear derailleur's upper pulley alignment with the second gear of the freewheel (as shown below).

If the upper pulley is not perfectly aligned with the corresponding gear, it can be corrected by adjusting the cable tension.

To adjust the rear derailleur's alignment:

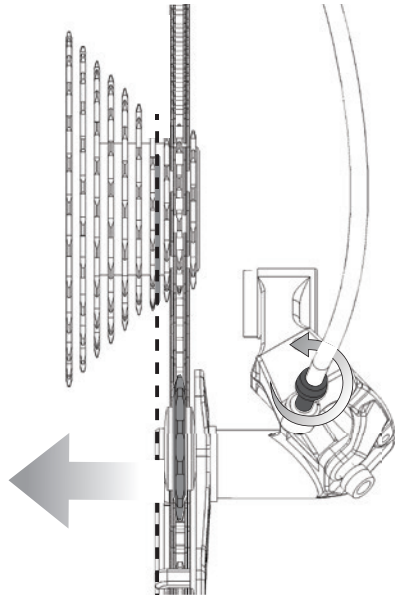

1. Turn the rear derailleur's barrel adjuster counter-clockwise to increase cable tension and move the derailleur pulleys to the left.

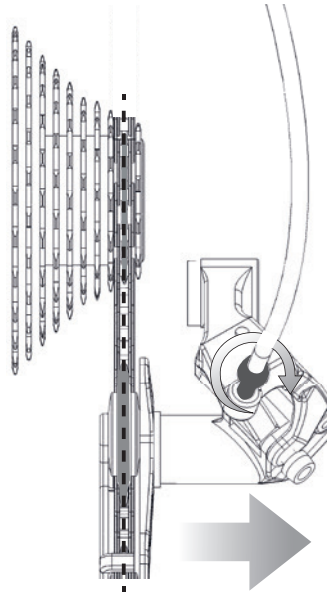

2. Turn the barrel adjuster clockwise to decrease cable tension and move the derailleur pulleys to the right.

To check the front derailleur's alignment:

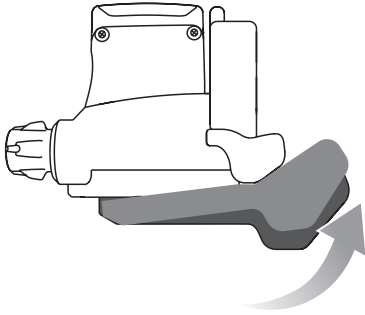

1. Use the right-hand side shifter to put the chain on the lowest rear gear (biggest sprocket on the freewheel).

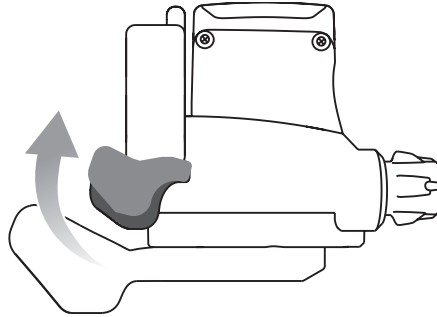

2. Use the left-hand side shifter to put the chain on the middle front gear.



3. Check that the front derailleur's cage inside surface is as close as possible to the chain without touching it. Recommended distance is 0.5 to 1 mm (as shown below)

To adjust the front derailleur's alignment:

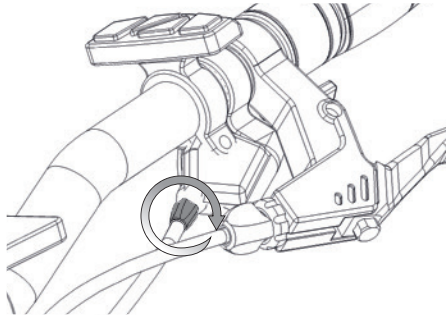
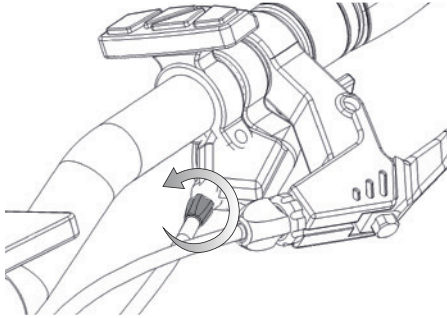

1. Turn the left shifter barrel adjuster counter-clockwise to increase cable tension and move the front derailleur cage closer to the chain.

2. Turn the barrel adjuster clockwise to decrease cable tension and move the derailleur cage away from the chain

## QUICK RELEASE BINDER SYSTEM ADJUSTMENT



*A quick-release attachment system is a very safe and reliable mechanism. However, it needs to be properly adjusted to ensure its efficiency and your safety. Make sure you understand its function before using it.*

This type of binder is most commonly used to attach wheels to the frame and fork as well as to tighten adjustable components such as the seat beam and handlebar's stem. They allow for quick tool-free adjustments.

Common locations of quick-release levers mechanisms:

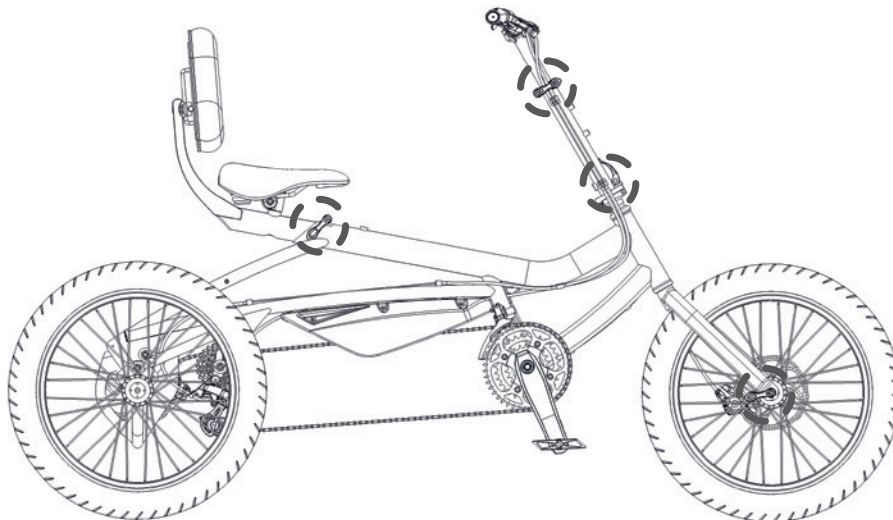



## How does it work?

A quick release lever attachment system uses what is called a "cam" mechanism. Contrarily as a "regular" tightening lever, this system is tightened by pushing the lever laterally, not turning it radially.

It is important to understand this principle in order to tighten the attachments in a safe way and to avoid permanent damage to the components.

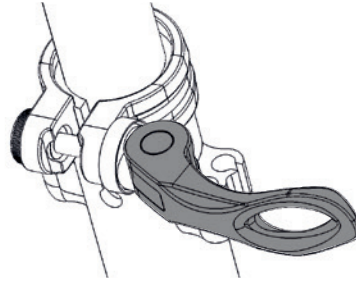

1. Quick Release lever in closed (tightened) position

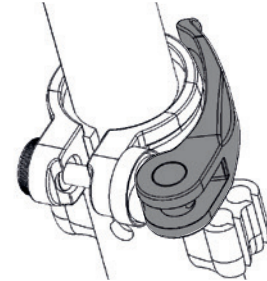

2. Quick Release lever in opened (loose) position

## To tighten a quick release attachment system:

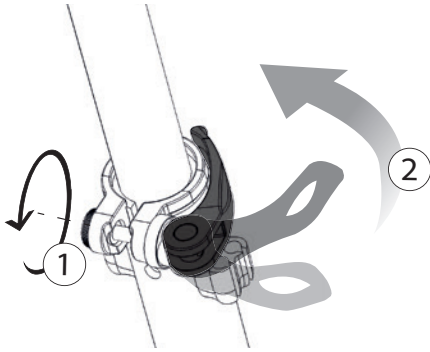

*A poorly tightened quick release attachment can lead to a disconnection of the components and result in serious injuries.*

1. Tighten the adjustment barrel so that a significant\* amount of force is required to push the lever in closed position.
2. Firmly push the lever in closed position with the palm of your hand.

*\* The precise force value required to push the lever so that the attachment system is efficiently tightened can vary with time and from one system to another. It is recommended that you test the attachment of the components each time it is opened and closed.*

## FOLDING THE STEM

On some Trivel models, it is possible to fold the stem. Once folded, it is much more compact for storage and easier to put in a car booth for transportation.

In order to fold the stem, refer to the specific instructions provided separately and make sure to respect the corresponding safety warnings.

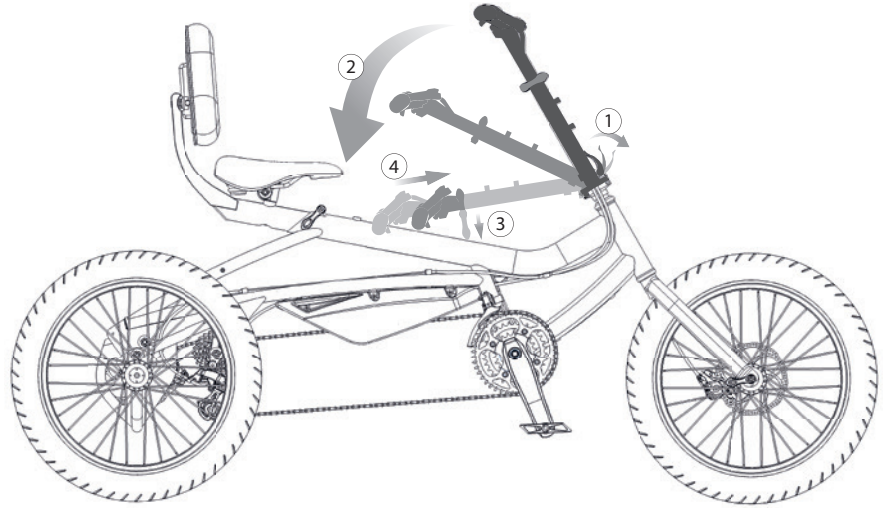

1. Undo the quick release attachment lever (Push the safety button device priorly if required).
2. Fold down the stem and handlebar assembly (Caution not to let it drop heavily as it could dent the frame's paint finish).

### Optional:

3. Undo the quick release lever of the upper part of the stem.
4. Push the sliding part further inside the stem to make it more compact.

## LUBRICATING THE CHAIN

### When to lubricate?

Lubricate your chain before storing for a long period, after it has been in contact with water, after washing your Trivel, after a muddy off-road ride or after about 250 km in normal conditions.

The chain should be lubricated with a bike specific lubricant. Do not use grease or motor oil.

Your local bike dealer can recommend the best type of lubricant for your chain based on your location and your type of riding.

### How to proceed:

Apply a small amount of lubricant over the full length of the chain by gently pouring oil over the chain while slowly rotating the pedal counter clockwise.

Let the lubricant penetrate the chain links for a few minutes and remove excess lubricant on the outside of the chain with a cloth. This will prevent dust or sand to stick to the chain and keep it running smooth.

Be careful not to put lubricant on brake system components such as the disc brake rotors or the rim's sidewalls as this could negatively affect braking performance. If you accidentally do, promptly clean the component with rubbing alcohol on a cloth (Warning: Do not use car brake cleaner or degreaser on disc brake system).

## WASHING YOUR TRIVEL

Keeping your Trivel clean is an easy and simple way to help extend its performance and look.

### To wash your Trivel:

1. Remove the battery if your Trivel is equipped with an electric power assistance system.
2. Find a proper area where there is no dust.
3. Fill a bucket with warm water and mix a biodegradable dishwashing liquid or other soft soap.
4. Clean transmission components such as chain, sprockets, and chain rings first with degreaser using specially designed brushes or a dedicated cloth.
5. Thoroughly wash the frame and components from top to bottom with soapy water using a soft brush.
6. Rinse with water at low pressure (Do not use a pressure washer as it can get water into sealed components).

7. Dry the chain with a clean cloth and re-lubricate it before letting it to air dry.



*Never apply degreaser or lubricant on disc rotor or brake pads. If degreaser or lubricant gets on a brake pad, it might need to be replaced.*



*Disc rotors, if needed, should only be cleaned with isopropyl alcohol on a clean cloth. Do not use car brake cleaner fluid.*

## STORING YOUR TRIVEL

It is recommended to store your Trivel in a tempered dry place, preferably indoor or inside a locked shed.

Make sure the chain and other corrosion-sensitive components have been lubricated before storing your Trivel for a prolonged period as rust can accumulate quickly in humid condition.

Be careful to store your Trivel away from other objects that may get in contact with impact-sensitive components such as wheels and derailleurs.

Check that there is sufficient pressure in the tires so the rubber doesn't degrade over a long storage period.

If you plan to leave your Trivel outside, we recommend that you lock it and cover it with a tarp to protect from water and allow air circulation.



*Do not store the battery in a place where temperature and humidity levels are not controlled. Ideal place of storage is inside, at a normal ambient temperature.*

## NORMAL WEAR

Some components on your Trivel will wear due to their normal usage. Brake pads, chain, tires and rims, amongst other, are subject to normal wear.

Those components should be replaced before they are completely worn out to preserve safety and performance as well as to prevent damage to other components of your equipment.

Components subject to normal wear usually have a wear indicator integrated or at least a dedicated tool available to check wear.



*Periodic inspection of your Trivel by a qualified technician is recommended to spot worn out components and identify compatible replacement parts*

## Brake pads

Replace disc brake pads when material thickness reached 1 mm or less.

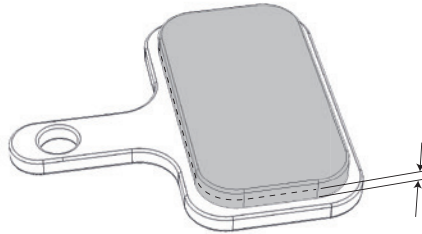

## Chain

It is generally recommended to replace a chain before it has been stretched by 0.75% of its initial length. A qualified technician has the knowledge and tool to measure your chain stretch.

## Tires

Replace tire when tread is not visible anymore or if it has suffered an unreparable puncture or damage.

## Rims

Replace a rim (or complete wheelset) when it was damaged to a point where it is not repairable by a qualified technician or when it shows signs of structural failure such as cracks around the spoke holes.

# TROUBLESHOOTING

PROBLEM	POSSIBLE CAUSES	SOLUTION
Rear gears not shifting correctly	<ul style="list-style-type: none"><li>• Derailleur is not synchronized with shifter</li><li>• Derailleur hanger is bent</li><li>• Friction in the cable housings</li><li>• Dirt or corrosion in the shifter</li><li>• Chain is damaged</li></ul>	<ul style="list-style-type: none"><li>• Adjust cable tension</li><li>• Align derailleur hanger</li><li>• Lubricate or replace cable housing</li><li>• Lubricate or replace shifter</li><li>• Fix or replace chain</li></ul>
Front gears not shifting correctly	<ul style="list-style-type: none"><li>• Derailleur is not synchronized with shifter</li><li>• Derailleur position is wrong</li><li>• Friction in the cable housings</li><li>• Dirt or corrosion in the shifter</li><li>• Chain is damaged</li></ul>	<ul style="list-style-type: none"><li>• Adjust cable tension</li><li>• Adjust derailleur alignment and height</li><li>• Lubricate or replace cable housing</li><li>• Lubricate or replace shifter</li><li>• Replace chain</li></ul>
Chain drops...	<ul style="list-style-type: none"><li>• From smallest rear sprocket</li><li>• From largest rear sprocket</li><li>• From smallest front chainring</li><li>• From largest front chainring</li></ul>	<ul style="list-style-type: none"><li>• Rear derailleur high (H) limit is too loose</li><li>• Rear derailleur low (L) limit is too loose</li><li>• Front derailleur high (H) limit is too loose</li><li>• Front derailleur low (L) limit is too loose</li><li>• Turn high (H) limit bolt clockwise</li><li>• Turn high (L) limit bolt clockwise</li><li>• Turn high (H) limit bolt clockwise</li><li>• Turn high (L) limit bolt clockwise</li></ul>



PROBLEM	POSSIBLE CAUSES	SOLUTION
<b>Chain won't reach...</b> <ul style="list-style-type: none"> <li>• The smallest rear sprocket</li> <li>• The largest rear sprocket</li> <li>• The smallest front chainring</li> <li>• The largest front chainring</li> </ul>	<ul style="list-style-type: none"> <li>• Rear derailleur high (H) limit is too tight</li> <li>• Rear derailleur low (L) limit is too tight</li> <li>• Front derailleur high (H) limit is too tight</li> <li>• Front derailleur low (L) limit is too tight</li> </ul>	<ul style="list-style-type: none"> <li>• Turn high (H) limit bolt counter clockwise</li> <li>• Turn high (L) limit bolt counter clockwise</li> <li>• Turn high (H) limit bolt counter clockwise</li> <li>• Turn high (L) limit bolt counter clockwise</li> </ul>
<b>Chain skips</b>	<ul style="list-style-type: none"> <li>• Chain is worn out</li> <li>• One or many sprockets worn out</li> <li>• One or many chainrings worn out</li> <li>• Sprocket or chainring has a broken tooth</li> </ul>	<ul style="list-style-type: none"> <li>• Replace chain</li> <li>• Replace sprockets</li> <li>• Replace chainrings</li> <li>• Replace sprocket or chainring</li> </ul>
<b>Weak braking</b>	<ul style="list-style-type: none"> <li>• Brakes are not properly adjusted</li> <li>• Brake pads are worn out</li> <li>• Rim or disc is dirty</li> </ul> <p><b>Hydraulic disc brakes</b></p> <ul style="list-style-type: none"> <li>• Brake fluid is missing</li> <li>• Air bubble in the hydraulic line</li> </ul>	<ul style="list-style-type: none"> <li>• Adjust brakes</li> <li>• Replace brake pads</li> <li>• Clean rim or disc</li> </ul> <ul style="list-style-type: none"> <li>• Add brake fluid</li> <li>• Bleed the hydraulic line</li> </ul>
<b>Vibrations while braking</b>	<ul style="list-style-type: none"> <li>• Loose headset bearings</li> <li>• Brake are not properly adjusted</li> <li>• Brake pivots are loose</li> <li>• Rim or disc rotor wobbling</li> <li>• Front wheel not properly attached</li> </ul>	<ul style="list-style-type: none"> <li>• Adjust headset bearings</li> <li>• Adjust brakes / Add an angle (toe-in)</li> <li>• Tighten brake pivots</li> <li>• Align or replace rim or disc rotor</li> <li>• Align and tighten front wheel into fork</li> </ul>

PROBLEM	POSSIBLE CAUSES	SOLUTION
Squeaking sound when braking	<ul style="list-style-type: none"> <li>• Brake pads are wet or dirty</li> <li>• Brake pads are not properly adjusted</li> <li>• Brake pads are worn out</li> <li>• Rim is wet or dirty</li> </ul>	<ul style="list-style-type: none"> <li>• Clean or replace brake pads</li> <li>• Adjust brake pads / Add an angle (toe-in)</li> <li>• Replace brake pads</li> <li>• Clean the rim</li> </ul>
	<p><b>Disc brakes</b></p> <ul style="list-style-type: none"> <li>• Disc rotor is wet or dirty</li> <li>• Brake pads are glazed or oil contaminated</li> <li>• Brake pads are worn out</li> <li>• Disc rotor is wobbling</li> <li>• Disc rotor attachment is loose</li> <li>• Brake caliper is loose</li> </ul>	<ul style="list-style-type: none"> <li>• Clean disc rotor</li> <li>• Sand or replace brake pads</li> <li>• Replace brake pads</li> <li>• Align or replace disc rotor</li> <li>• Tighten disc rotor attachment</li> <li>• Tighten brake caliper bolts</li> </ul>
Rubbing sound when riding	<ul style="list-style-type: none"> <li>• Brake pads are rubbing against rim or disc</li> <li>• Rim or disc rotor is rubbing against brake pads</li> <li>• Chain in crossed gear combination</li> <li>• Object interfering with wheels or crank arms</li> </ul>	<ul style="list-style-type: none"> <li>• Adjust brake pads spacing</li> <li>• Align rim or disc rotor</li> <li>• Shift gear to another combination</li> <li>• Remove interfering object</li> </ul>
Creaking sound when pedalling	<ul style="list-style-type: none"> <li>• Loose or dirty bottom bracket</li> <li>• Loose crank arms</li> <li>• Damaged pedals bearings</li> <li>• Chain is dirty or rusted</li> <li>• Stiff chain link</li> <li>• Chain tension too high (for single speed bike)</li> </ul>	<ul style="list-style-type: none"> <li>• Tighten and clean bottom bracket</li> <li>• Tighten crank arms</li> <li>• Fix or replace pedals</li> <li>• Clean and lubricate chain</li> <li>• Fix or replace chain</li> <li>• Adjust chain tension</li> </ul>

PROBLEM	POSSIBLE CAUSES	SOLUTION
<p>Poor handling</p>	<ul style="list-style-type: none"> <li>• Headset bearings are too tight</li> <li>• Wheels not centered in frame and fork</li> <li>• Stem / handlebar is misaligned with fork</li> <li>• Fork is bent</li> <li>• Frame is bent</li> </ul>	<ul style="list-style-type: none"> <li>• Adjust headset bearings</li> <li>• Center wheels in frame and fork</li> <li>• Align stem / handlebar with fork</li> <li>• Fix or replace fork</li> <li>• Fix or replace frame</li> </ul>
<p>Frequent flats</p>	<ul style="list-style-type: none"> <li>• Riding with a too low pressure (pinch flat)</li> <li>• Sharp object stuck inside tire</li> <li>• Damaged inner tube</li> <li>• Damaged tire</li> <li>• Rim tape misplaced</li> </ul>	<ul style="list-style-type: none"> <li>• Increase tire pressure</li> <li>• Remove and fix or replace inner tube</li> <li>• Fix or replace inner tube</li> <li>• Fix or replace tire</li> <li>• Reposition rim tape</li> </ul>

## WARRANTY TERMS

By the present, Trivel gives notice to the owner or the user of an Electrically Assisted Vehicle of the provisions of the limited warranty that Trivel offers the owner following the purchase of the equipment from an authorized Trivel dealer.

### Warranty against hidden defects

Trivel warrants to the owner that its equipment, when new, is exempt from hidden defects. Should the owner discover what he believes is a hidden defect, he must notify Trivel in writing within three (3) days from the moment when he or she first becomes aware of said defect in order to give Trivel the opportunity to correct said defect if possible, at the sole discretion of Trivel and provided Trivel can establish said hidden defect is present before the expiration of the warranty.

### Warranty against apparent anomaly

The owner must verify the apparent condition, the quantity and the contents of the equipment following the purchase and, on the same day, must immediately proceed with a complete inspection of it with the help from the owner's manual. If there is damage, if a part is missing or is damaged, if the equipment is broken, or if there are other problems of the same kind (hereafter known as: 'Apparent anomaly'), the owner must contact the dealer immediately and notify Trivel within three (3) days from the date of purchase from the dealer by registered letter, a receipt for which must be kept for reference. Should the owner not advise of the Apparent anomaly within the prescribed time period, Trivel shall not be responsible for any prejudice suffered by the owner due to the Apparent anomaly and the equipment shall be deemed free of any Apparent anomaly when purchased and the owner deemed satisfied with the purchase.

### Propulsion system warranty

Trivel warrants to the owner that the propulsion system included with the equipment, when new, is in good working condition. **This warranty shall expire twenty-four (24) months following the purchase date of the equipment from the dealer.** The propulsion system is defined as including the **control display, the accelerator components, the motor, the wiring cluster parts and the electric cables.**

## Frame

Trivel warrants to the owner that the frame of the electrically assisted vehicle when new, is free from defects in materials and workmanship. **This warranty shall expire thirty-six (36) months following the purchase date of the equipment from the dealer.** The frame excludes the battery, all the electric components, the paint and finish, the front fork, the wheels, the tires, the drive train, the brakes, the saddle post, the handlebar and stem and any suspension component or part.

## Useful life warranty

As for any other consumer good, the electrically assisted vehicle has a useful life cycle. The length of the useful life cycle can vary depending on the criteria chosen for workmanship and materials of the equipment as well as the kind of use and frequency to which the vehicle has been subjected. However, Trivel advises the owner that the

maintenance and upkeep performed on the equipment during its useful life cycle are very important as a means of prolonging the useful life cycle of the product. Consequently, Trivel advises the owner that the equipment must be checked periodically by the dealer as general maintenance of the product and as a means of detecting stress and/or potential failures including, but without limiting the generality of the preceding, cracks, deformations, corrosion, paint chipping, dents and any other indications of potential problems, improper use or abuse. These regular verifications are important safety checks and they are essential in helping to prevent accidents, bodily injury and premature reduction of the useful product life cycle of the equipment.

## Merchandise return policy during warranty period

If a defect occurs during the warranty period, the parts (batteries, controller, or any other parts of the bicycle) will have to be shipped to Trivel directly from an

authorized Trivel retailer and, following repairs, Trivel shall ship the parts back without charge to the retailer exclusively. If the shipping address is different than the nearest Trivel retailer's the customer shall have to pay shipping costs both to and from said different address.

## Validity of the limited warranty

The Trivel limited warranty is conditional to the equipment having been handled and maintained adequately by the owner in accordance with the notices to the owner and the instructions printed in the owner's manual and on the equipment having been stored in appropriate conditions and at an adequate temperature given the specific characteristics of the equipment. To be able to benefit from the terms and conditions of the limited warranty offered by Trivel, the owner must fill a Trivel limited warranty form (which can be found at an authorized Trivel dealer and on Trivel website) and return it to the dealer with a

copy of the invoice obtained at the time of purchase to Trivel within thirty (30) days of the purchase date.

Without limiting the generality of the preceding, the Trivel limited warranty excludes components of the vehicle that are damaged by an error or negligence in the maintenance of the equipment and its components or resulting from a use that does not conform to the notice to the owner and to the Trivel owner's manual by the owner. With the exception of the parts specifically mentioned in the present limited warranty, the purchase of the electrically assisted vehicle is made at the risk and peril of the owner.

**During the warranty period, should there be a problem with your product, you should have repairs made by an authorized trivel retailer in order to conserve your rights under the warranty.**

Example: For a front wheel flat or tire replacement on a model equipped with an electrical power assistance system, the front wheel will have to be removed with the motor. Only a Trivel-trained person is qualified to perform this work without causing damages. It is thus strongly recommended that the owner contact an authorized Trivel representative to have the work performed. Should this not be done, the owner shall not hold Trivel liable for any damages caused by an improper procedure by a person who is unqualified and not authorized by Trivel.

### **The warranty is non-transferrable**

Trivel warrants to the owner that the battery included with the vehicle, when new, is in good working order. This warranty shall expire twenty-four (24) months following the purchase date of the equipment for a Lithium battery.

**Make sure that the battery was new when purchased. The year of the battery is within the serial number.**

**The battery must be charged at least every two months.**

**Should these instructions not be followed, there is a risk of battery malfunction and this will not be covered by the limited warranty.**



AZTECA



USER MANUAL

1 877 687-7676 | [TRIVEL.COM](https://www.trivel.com)